

RECOMMENDED OPERATING FLOW:
MATE: 1
UNMATE: 2

0	----	Schumi	Mar,27,2020
REV	ECN NO.	NAME	DATE

TOLERANCE	
LINEAR	ANGLES
X.±0.40	X'±
.X±0.30	.X'±
.XX±0.20	.XX'±
.XXX±0.10	.XXX'±

UMax 东莞市友贸实业有限公司	
DONGGUAN UMAX ENTERPRISE LIMITED	
APPD: Jason	MAT'L:
CHKD: Schumi	FINISH:
DRWN: Terry	Q'TY:

TITLE: M.2 CONN. P=0.5 6.7mm H				
PART NO. 91302-67-067RXX				
DWG NO. C-91302-67				
	UNITS	SCALE	SHEET	REV
	MM	1 : 1	1 OF 4	0

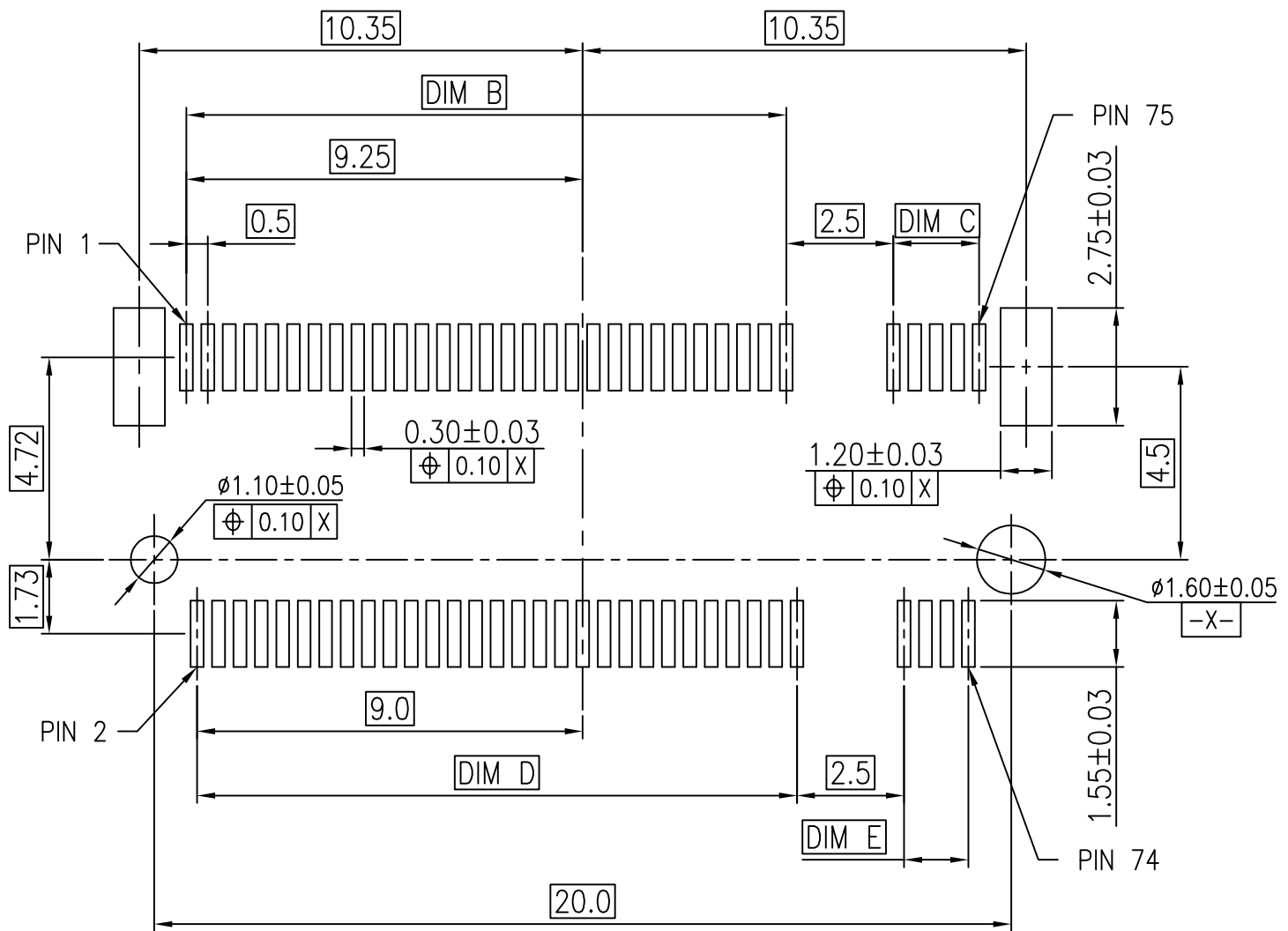

REV	SEE SHEET 1	NAME	DATE
	ECN NO.		

TOLERANCE	
LINEAR	ANGLES
X.±0.40	X'±
.X±0.30	.X'±
.XX±0.20	.XX'±
.XXX±0.10	.XXX'±

UMax conn 东莞市友贸实业有限公司 DONGGUAN UMAX ENTERPRISE LIMITED	
APPD: Jason	MAT'L:
CHKD: Schumi	FINISH:
DRWN: Terry	Q'TY:

TITLE:		M.2 CONN. P=0.5 6.7mm H			
PART NO.		91302-67-067RXX			
DWG NO.		C-91302-67			
	UNITS	SCALE	SHEET	REV	
	MM	1 : 1	2 OF 4	0	

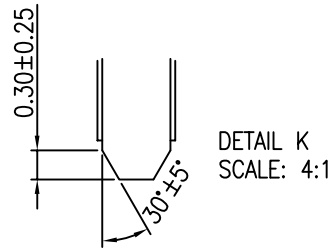
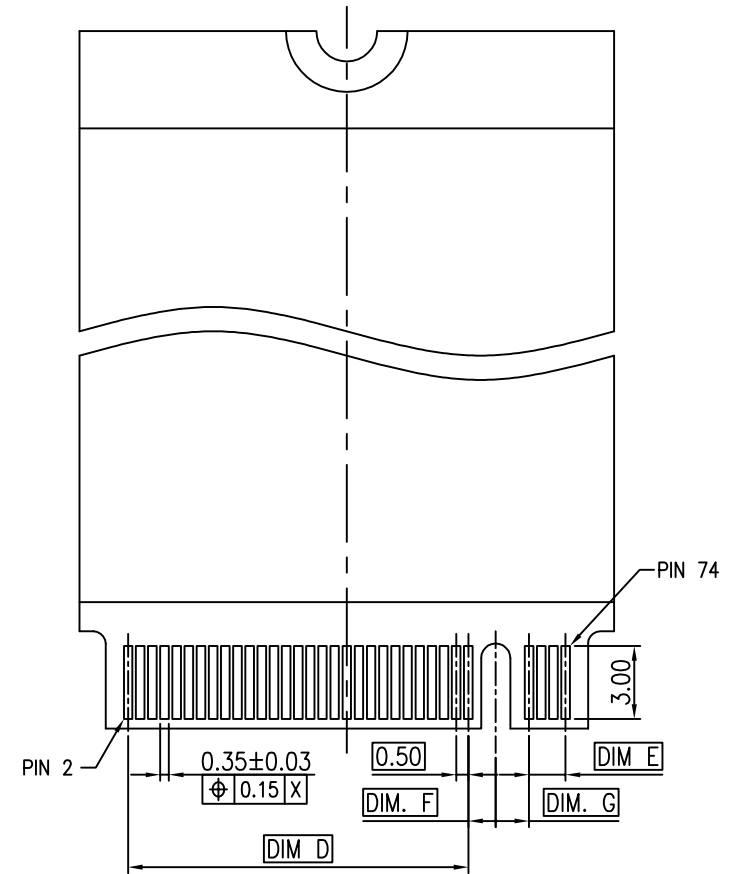
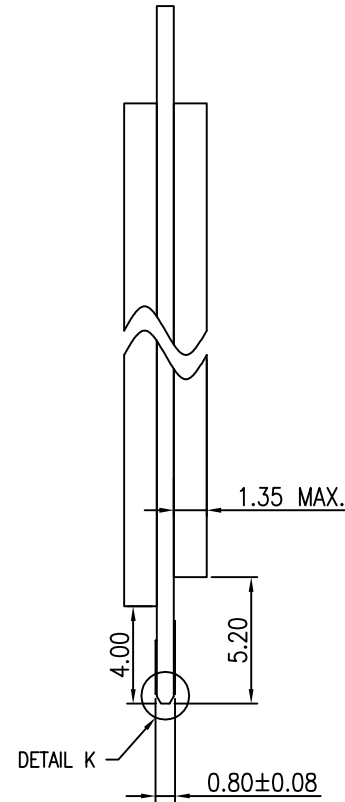
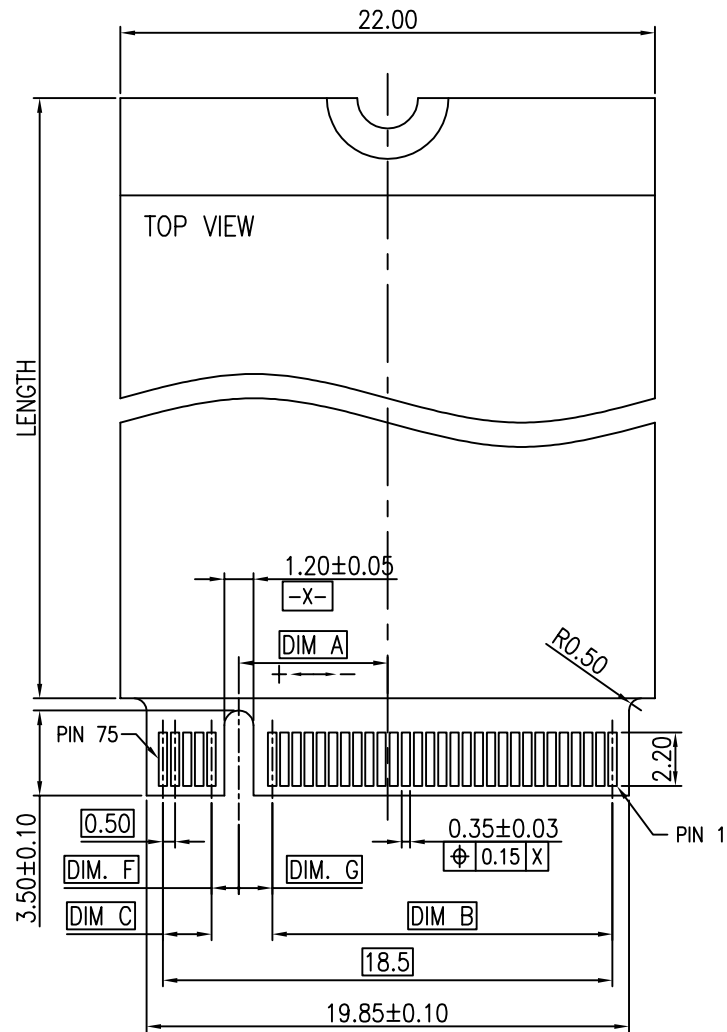

TOLERANCE		UMax 东莞市友贸实业有限公司 DONGGUAN UMAX ENTERPRISE LIMITED		TITLE: M.2 CONN. P=0.5 6.7mm H			
LINEAR	ANGLES	APPD: Jason MAT'L:		PART NO. 91302-67-067RXX			
X.±0.40	X'±			DWG NO. C-91302-67			
.X±0.30	.X'±	CHKD: Schumi	FINISH:	UNITS	SCALE	SHEET	REV
.XX±0.20	.XX'±	DRWN: Terry	Q'TY:	MM	1 : 1	3 OF 4	0
.XXX±0.10	.XXX'±			CUSTOMER			

REV	ECN NO.	NAME	DATE
	SEE SHEET 1		

NOTES:

1. MATERIAL :
 - 1.1 HOUSING: THERMOPLASTIC, HIGH TEMPERATURE,
UL94 V-0, COLOR: BLACK.
 - 1.2 CONTACT: COPPER ALLOY.
 - 1.3 FITTING NAIL: COPPER ALLOY.
2. FINISH :
 - 2.1 CONTACT
[SEE TABLE] GOLD PLATING ON THE CONTACT AREA.
GOLD FLASH PLATING ON THE SOLDERING AREA.
1.27um~2.54um [50u"~100u"] MIN. NICKEL UNDERPLATING OVERALL.
 - 2.2 FITTING NAIL
2.54um~5.08um [100u"~200u"] MIN. MATTE-TIN PLATING ON THE SOLDERING AREA.
1.27um~2.54um [50u"~100u"] MIN. NICKEL UNDERPLATING OVERALL.
3. PACKAGING SPEC.: K-91302-402

PART NO.:

91302-67 - 067 R X X

67: 6.7mm HEIGHT

67 CONTACTS

PACKING OPTIONS
R: TAPE & REEL

KEY ID OPTIONS
A, B, C, D, E, F
G, H, J, K, L, M

CONTACT AREA PLATING
2: GOLD FLASH
C: 15u" GOLD
D: 30u" GOLD

1.375	1.125	1.5	14.0	2.0	14.0	6.125	M
1.375	1.125	2.5	13.0	3.0	13.0	5.125	L
1.375	1.125	3.5	12.0	4.0	12.0	4.125	K
1.375	1.125	4.5	11.0	5.0	11.0	3.125	J
1.375	1.125	5.5	10.0	6.0	10.0	2.125	H
1.375	1.125	6.5	9.0	7.0	9.0	1.125	G
DIM. G	DIM. F	DIM. E	DIM. D	DIM. C	DIM. B	DIM. A	KEY ID

1.125	1.375	9.5	6.0	9.5	6.5	-1.625	F
1.125	1.375	10.5	5.0	10.5	5.5	-2.625	E
1.125	1.375	11.5	4.0	11.5	4.5	-3.625	D
1.125	1.375	12.5	3.0	12.5	3.5	-4.625	C
1.125	1.375	13.5	2.0	13.5	2.5	-5.625	B
1.125	1.375	14.5	1.0	14.5	1.5	-6.625	A
DIM. G	DIM. F	DIM. E	DIM. D	DIM. C	DIM. B	DIM. A	KEY ID

TOLERANCE		UMax 东莞市友贸实业有限公司 DONGGUAN UMAX ENTERPRISE LIMITED	
LINEAR	ANGLES	APPD:	MAT'L:
X.±0.40	X'±	Jason	
.X±0.30	.X'±	CHKD: Schumi	FINISH:
.XX±0.20	.XX'±	DRWN: Terry	Q'TY:
.XXX±0.10	.XXX'±		

TITLE:		M.2 CONN. P=0.5 6.7mm H			
PART NO.		91302-67-067RXX			
DWG NO.		C-91302-67			
UNITS	SCALE	SHEET	REV		
				MM	1 : 1

REV	SEE SHEET 1	ECN NO.	NAME	DATE

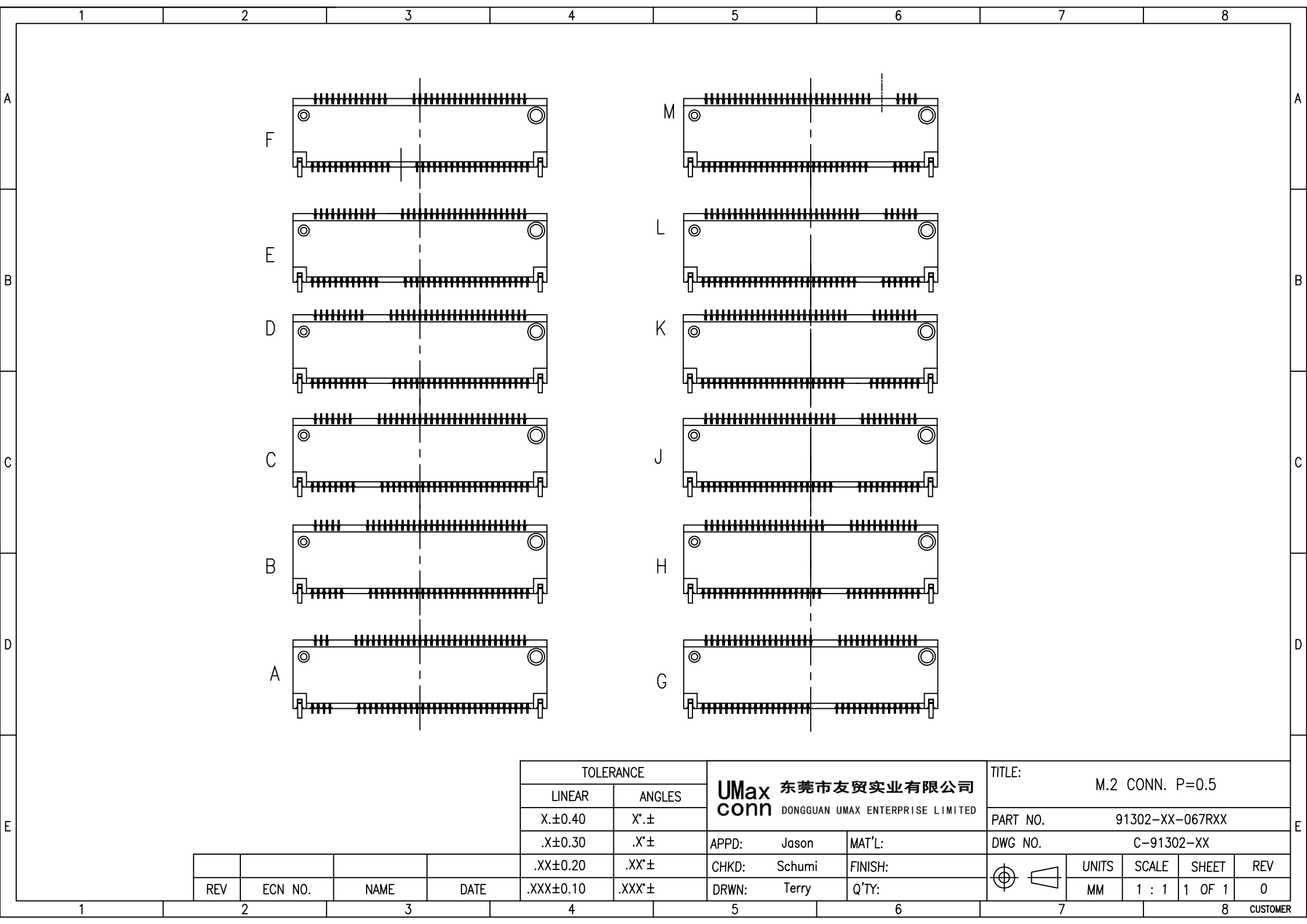

TOLERANCE		UMax 东莞市友贸实业有限公司 conn DONGGUAN UMAX ENTERPRISE LIMITED
LINEAR	ANGLES	
X.±0.40	X'±	APPD: Jason MAT'L: CHKD: Schumi FINISH: DRWN: Terry Q'TY:
.X±0.30	.X'±	
.XX±0.20	.XX'±	
.XXX±0.10	.XXX'±	

TITLE:		M.2 CONN. P=0.5			
PART NO.		91302-XX-067RXX			
DWG NO.		C-91302-XX			
	UNITS	SCALE	SHEET	REV	
	MM	1 : 1	1 OF 1	0	

REV	ECN NO.	NAME	DATE
-----	---------	------	------