

Circuit diagram

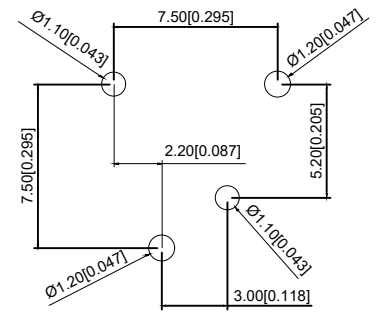

PCB SOLDER LAND DIMENSIONS

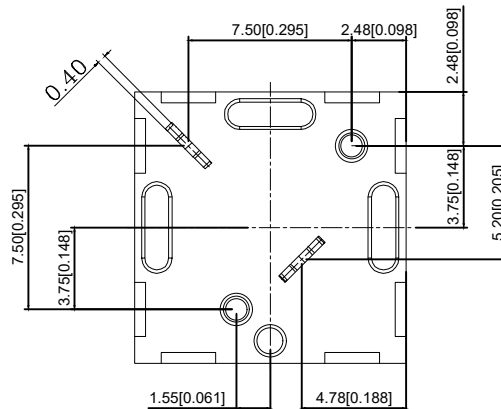
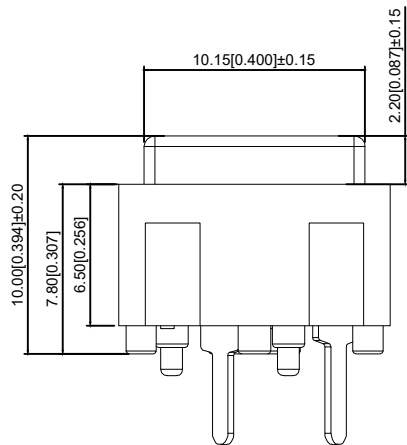

Rated electric load: AC/DC50V 25mA
 额定电负荷: AC/DC12V 25mA
 Withstand voltage strength: AC500V (50/60Hz foy 1minute)
 耐压强度: AC500V (50/60Hz foy 1minute)
 Insulation resistance: ≥ 100MΩ min(DC100v)
 绝缘电阻: ≥ 100MΩ min(DC100V)
 Contact impedance: 100M Ω Max
 接触阻抗: 100mΩ max
 Electrical life: 30000 cycles min
 电气寿命: 30000 cycles min
 Conduction stroke: 0.6mm (±0.3mm)
 导通行程: 0.6mm (±0.3mm)
 Action force: 300gf ± 100gf
 力度: 300gf ± 100gf
 Operation type: touch reply
 操作类型: 触动回复式

4	terminal	2	BASS	silver (Ag)
3	Shrapnel	1	SUS	Concave gold coating
2	Base	1	PA46	black
1	Press handle	1	ABS	black
Serial number	NAME	QUANTITY	Texture of material	Plating/colour

A4			
A3			
A2			
A1			
REV	DATE	REVISION DESCRIPTION	ISSUE



COMMON TOLERANCE

X.XX	± 0.10
X.X	± 0.15
X	± 0.25
ANGULAR	—

UNIT	MM	PROJECTED		PRODUCT NAME:
DRAWN BY	FUYUAN	CHECKED BY	COCO	MODEL NO: TP-66015
DATE	2019	APPROVAL B	ALEN	Https: www.rocpcu.tw
ROCPCU TECHNOLOGY CO.,LTD				
Copies are issued in strict confidence and shall not be reproduced or copied, or used as the basic of manufacture or sale of apparatus without permission				