

修 订	标 记	修 改 描 要	签 名	日 期
REV	MARK	REVISION DESCRIPTION	SIGNATURE	DATE
AO		NEW DWG		2016-03-12

1.MATERIAL  
HOUSING:LCP UL 94V-0  
ACTUATOR:LCP UL 94V-0  
CONTACTS:COPPER ALLOY  
PEG:COPPER ALLOY  
2.PLATING:  
CONTACTS:TIN OVER NICKEL  
PEG:TIN OVER NICKEL  
3.PART NO:  
OPERATING VOLTAGE:50V AC,DC  
CURRENT RATING:0.3A AC,DC  
OPERATING TEMPERATURE:-25C~+85C

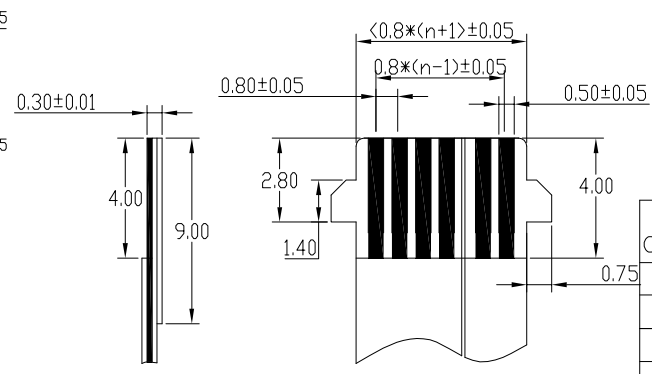

No. of Contacts	DIM.		
	A	B	C
12	14.70	8.80	10.45
24	24.30	18.40	20.05
28	27.50	21.60	23.25
30	29.10	23.20	24.85
32	30.70	24.80	26.45
34	32.30	26.40	28.05
36	33.90	28.00	29.65

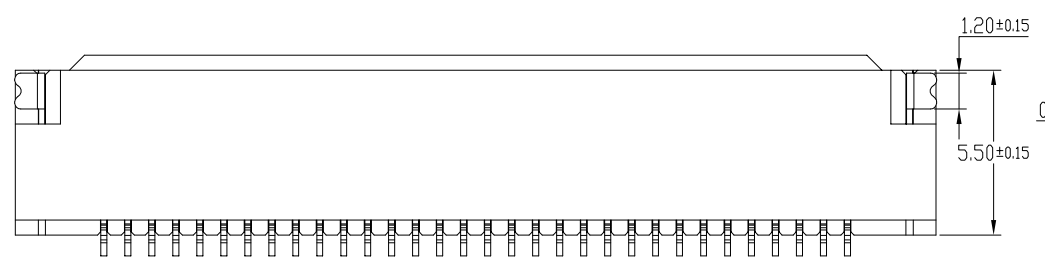
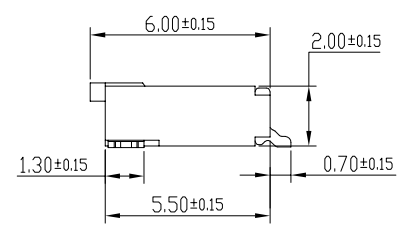
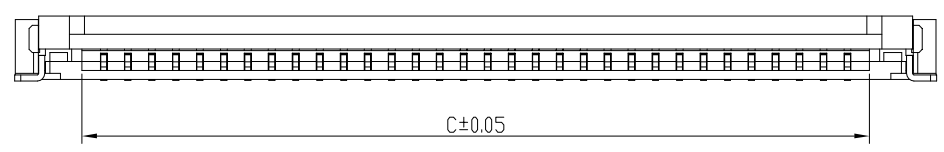
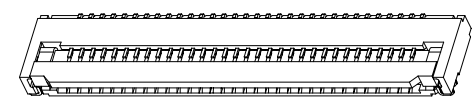
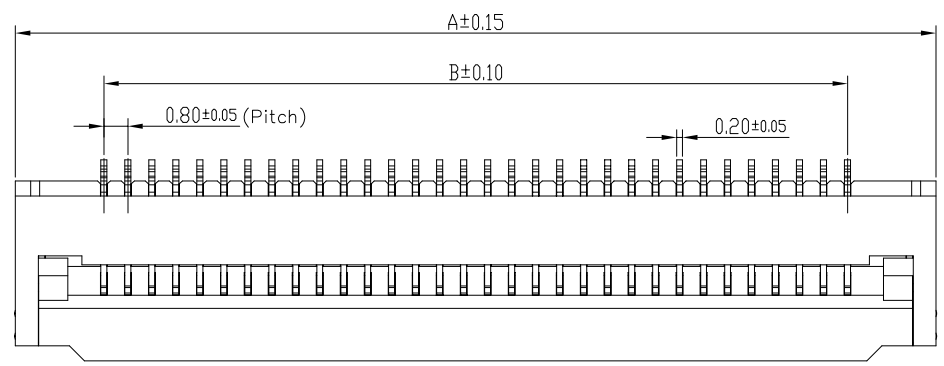
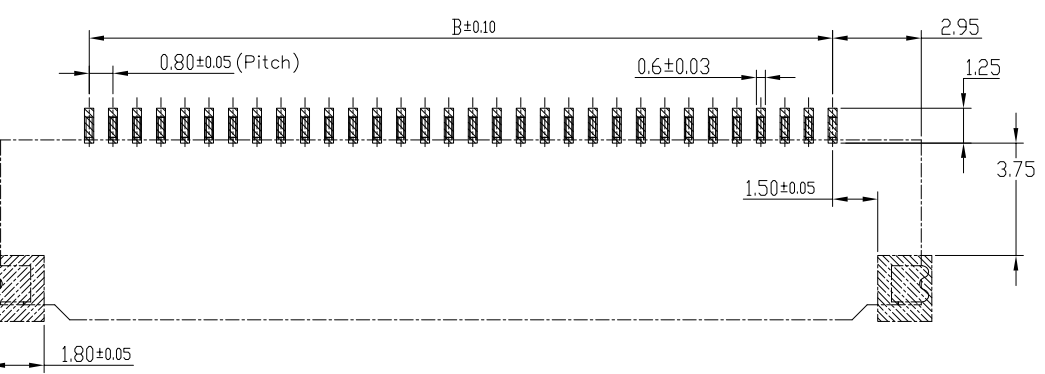

APPLICABLE FPC

		<b>深圳市华德共创科技有限公司</b> Shenzhen Huade co-create Technology Co.,LTD 电话: 0755-23304126 传真: 0755-29940187			
		-TOLERANCES- UNLESS OTHERWISE SPECIFIED 公差参数表			
X.X	±0.30	X.X*	±3°	APPD: 核准:	TITLE: 产品名称:0.8间距2.0高带扣掀盖式
X.XX	±0.20	X.XX*	±2°	CHECK: 校对: 王建业	PART NO: 产品编号: 0.8K-QX-nPWB
X.XXX	±0.10	X.XXX*	±1°	DRAW: 绘图: 黄艳兰	DATE: 2016-03-12 SCALE: 1:1 UNIT: mm CODE NUMBER: A001

修改		修改摘要		签名		日期	
REV	MARK	REVISION	DESCRIPTION	SIGNATURE	DATE		
AD		NEW DWG				2016-03-12	
REEL DIM							

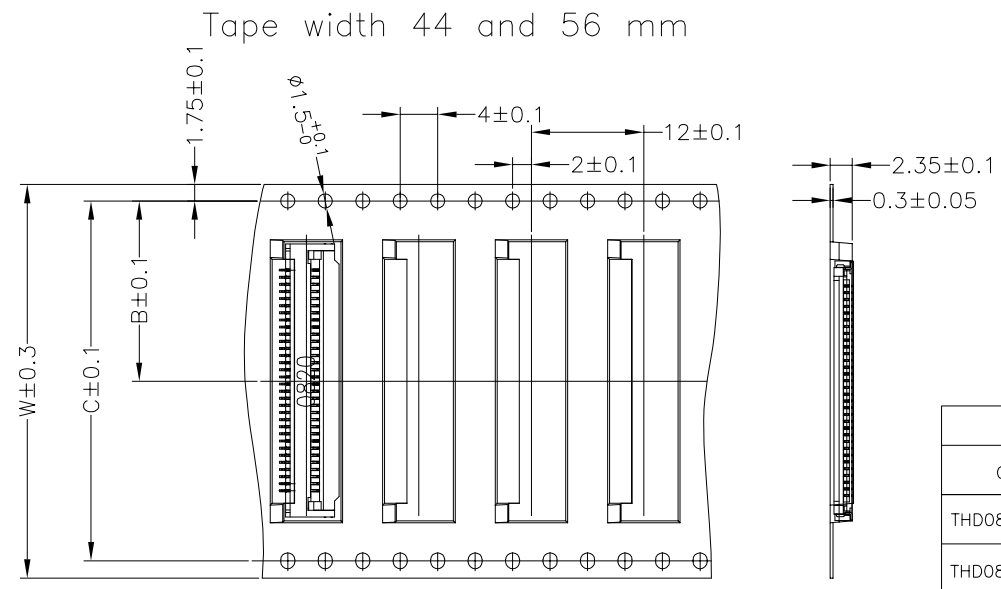
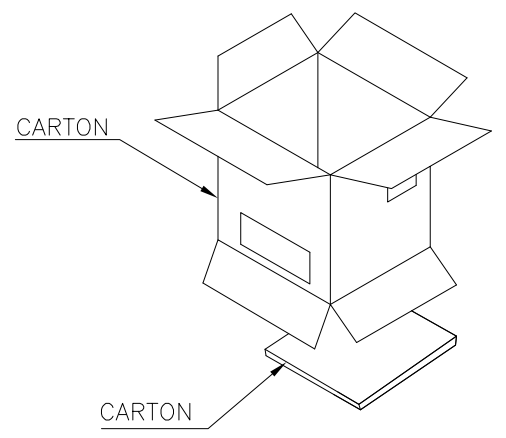
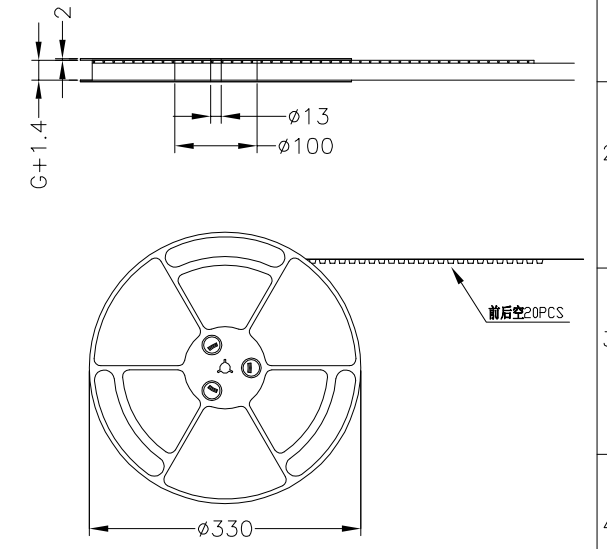
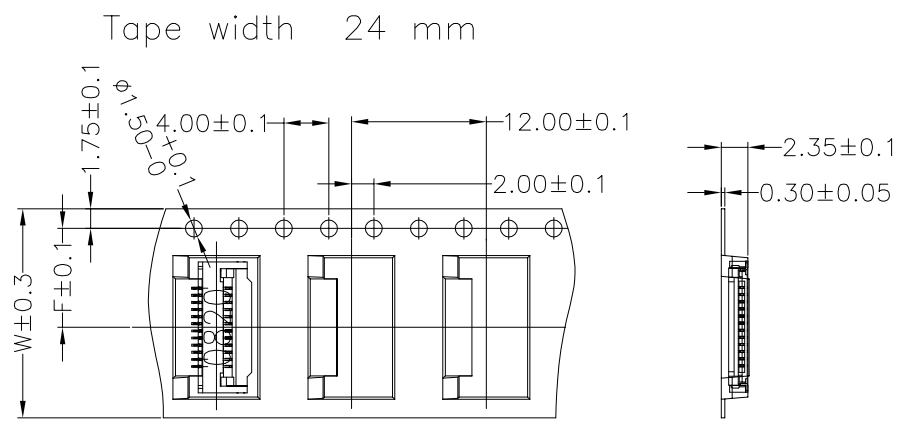
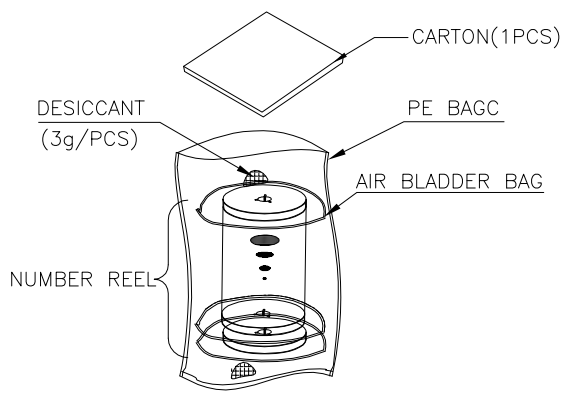

No.of Contacts	DIM			REEL (CARTON)	SUM(PCS)
	A	B	C		
THD0820 4pin-12pin	24	11.5	—	10	20000
THD0820 28pin~32pin	44	20.2	40.4	6	12000
THD0820 33pin~36pin	56	26.25	52.5	5	10000

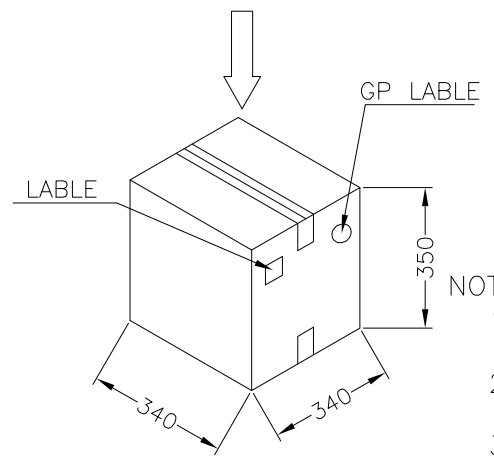

- NOTES:
- Component load per 13" reel: 2000 pcs
  - Material: black conductive polystyrene alloy.
  - Thickness:  $0.3 \pm 0.05$  mm
  - All dimensions meet eia-481-c requirements

深圳市华德共创科技有限公司  
Shenzhen Huade co-create Technology Co., LTD  
电话: 0755-23304126 传真: 0755-29940187

-TOLERANCES- UNLESS OTHERWISE SPECIFIED 公差参数表			TITLE: 产品名称: 0.8间距2.0高带扣掀盖式					
X.X	$\pm 0.30$	X.X*	$\pm 3^\circ$	APPD: 核准:				
X.XX	$\pm 0.20$	X.XX*	$\pm 2^\circ$	CHECK: 校对: 王建业				
X.XXX	$\pm 0.10$	X.XXX*	$\pm 1^\circ$	DRAW: 绘图: 黄艳兰				
				PART NO: 产品编号: 0.8K-QX-nPWB	DATE	SCALE	UNIT	CODE NUMBER
				2016-03-12	1:1	mm	A001	