

TMC260C & TMC261C DATASHEET

Highly efficient stepper drivers for two-phase motors with state-of-the-art features. Compatible upgrade to TMC260A and TMC261A. Up to 2 A motor coil current. Step/Dir Interface and SPI.

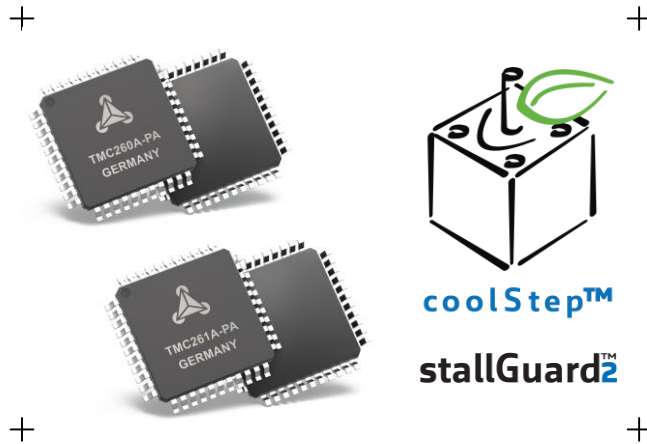

APPLICATIONS

Textile, Sewing Machines
Factory Automation
Lab Automation
Liquid Handling
Medical
Office Automation
Printer and Scanner
CCTV, Security
ATM, Cash recycler
POS
Pumps and Valves
HelioStat Controller
CNC Machines

FEATURES AND BENEFITS

- Drive Capability** up to 2A motor current
- Highest Voltage** up to 60V DC (TMC261) or 40V DC (TMC260)
- Highest Resolution** up to 256 microsteps per full step
- Compact Size** 10x10mm QFP-44 package
- Low Power Dissipation** low R_{DS(on)} & sync. rectification
- EMI-optimized** programmable slope, no charge pump
- Protection & Diagnostics** short to GND, overtemperature & undervoltage, overcurrent and short to VS (-C types only)
- StallGuard2™** high precision sensorless motor load detection
- CoolStep™** load dependent current control saves up to 75%
- MicroPlyer™** 256 microstep smoothness with 1/16 step input.
- SpreadCycle™** high-precision chopper for best current sine wave form and zero crossing
- Improved Silent Motor** operation (-C types only)
- Stand Alone** option (-C types only)

DESCRIPTION

The TMC260 and TMC261 drivers for two-phase stepper motors offer an industry-leading feature set, including high-resolution microstepping, sensorless mechanical load measurement, load-adaptive power optimization, and low-resonance chopper operation. Standard SPI™ and STEP/DIR interfaces simplify communication. Integrated power MOSFETs handle motor currents up to 2A per coil. Integrated protection and diagnostic features support robust and reliable operation. High integration, high energy efficiency and small form factor enable miniaturized designs with low external component count for cost-effective and highly competitive solutions.

The new -C types TMC260C & TMC261C improve motor silence and add low side short protection and a stand-alone mode.

BLOCK DIAGRAM

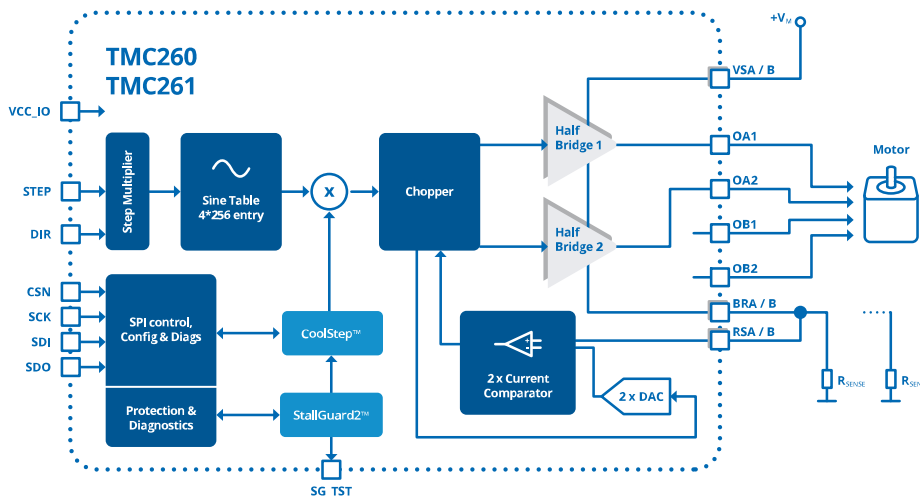

APPLICATION EXAMPLES: SMALL SIZE – BEST PERFORMANCE

The TMC260 and the TMC261 score with power density, integrated power MOSFETs, and a versatility that covers a wide spectrum of applications and motor sizes, all while keeping costs down. Extensive support at the chips, board, and software levels enables rapid design cycles and fast time-to-market with competitive products. High energy efficiency from TRINAMIC's CoolStep technology delivers further cost savings in related systems such as power supplies and cooling.

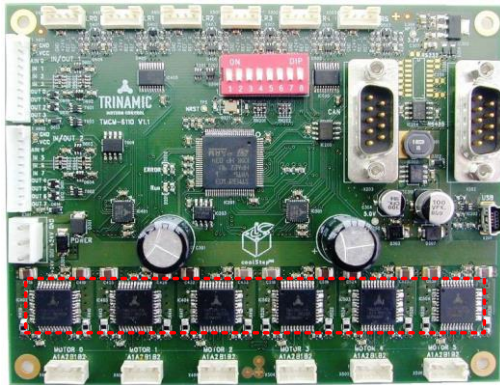

Layout for up to six stepper motors

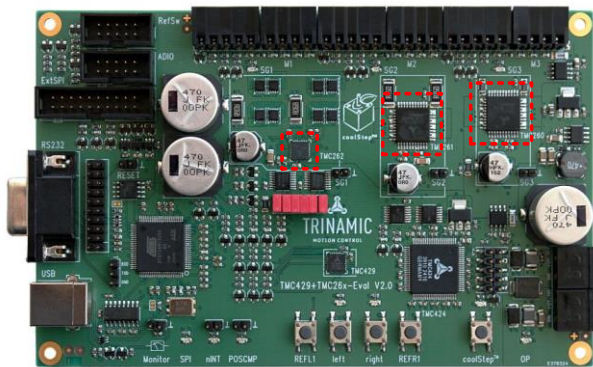

Layout for Evaluation

TCM-6110

FOR UP TO 6 STEPPER MOTORS

The TCM-6110 is a compact stepper motor controller / driver standalone board. It supports up to 6 bipolar stepper motors with up to 1.1A RMS coil current. The TMC260 has been tested successfully for 2A peak (1.4A RMS) on this module.

The TCM-6110 features an embedded microcontroller with USB, CAN and RS485 interfaces for communication.

All cooling requirements are satisfied by passive convection cooling.

TMC429+TMC26x EVAL

EVALUATION & DEVELOPMENT PLATFORM

This evaluation board is a development platform for applications based on the TMC260, TMC261, and TMC262.

Supply voltages are 8... 40V DC (TMC260) and 8... 60V DC (TMC261 and TMC262).

The board features an embedded microcontroller with USB and RS232 interfaces for communication. The control software provides a user-friendly GUI for setting control parameters and visualizing the dynamic responses of the motors.

Motor movements can be controlled through the step/direction interface using inputs from an external source or signals generated by the TMC429 motion controller acting as a step generator.

ORDER CODES

Order code	PN	Description	Size
TMC260C-PA	00-0183	CoolStep™ driver, up to 40V DC, TQFP-44	10 x 10 mm ²
TMC261C-PA	00-0184	CoolStep™ driver, up to 60V DC, TQFP-44	10 x 10 mm ²
TMC260C-PA-T	00-0183-T	-T devices are packaged in tape on reel	
TMC261C-PA-T	00-0184-T	-T devices are packaged in tape on reel	
TMC429+26x-EVAL	40-0030	Chipset evaluation board for TMC429, TMC260, TMC261, TMC262, and TMC424.	16 x 10 cm ²

*) The Term TMC260 and TMC261 is used for TMC260A / TMC261A or TMC260C / TMC261C within this datasheet. Differences in the C-types are explicitly marked with "C-type". See summary in section 15. Non-C-type information is only given for reference.

TABLE OF CONTENTS

1	PRINCIPLES OF OPERATION	4	11.2	ENN INPUT.....	40
1.1	KEY CONCEPTS.....	4	12	DIAGNOSTICS AND PROTECTION	41
1.2	CONTROL INTERFACES.....	5	12.1	SHORT PROTECTION.....	41
1.3	MECHANICAL LOAD SENSING.....	5	12.2	OPEN-LOAD DETECTION	42
1.4	CURRENT CONTROL	5	12.3	TEMPERATURE SENSORS.....	43
2	PIN ASSIGNMENTS	6	12.4	UNDERVOLTAGE DETECTION.....	43
2.1	PACKAGE OUTLINE.....	6	13	POWER SUPPLY SEQUENCING	45
2.2	SIGNAL DESCRIPTIONS	6	14	SYSTEM CLOCK	45
3	INTERNAL ARCHITECTURE	8	14.1	FREQUENCY SELECTION.....	46
4	STANDALONE OPERATION	9	15	COMPATIBILITY TO NON-C-TYPE	47
5	STALLGUARD2 LOAD MEASUREMENT	10	16	DRIVER PROTECTION AND EME CIRCUITRY	48
5.1	TUNING THE STALLGUARD2 THRESHOLD.....	11	17	LAYOUT CONSIDERATIONS	49
5.2	STALLGUARD2 MEASUREMENT FREQUENCY AND FILTERING	12	17.1	SENSE RESISTORS.....	49
5.3	DETECTING A MOTOR STALL	12	17.2	POWER MOSFET OUTPUTS.....	49
5.4	LIMITS OF STALLGUARD2 OPERATION.....	12	17.3	POWER SUPPLY PINS	49
6	COOLSTEP LOAD-ADAPTIVE CURRENT CONTROL	13	17.4	POWER FILTERING.....	49
6.1	TUNING COOLSTEP	15	17.5	LAYOUT EXAMPLE	50
7	SPI INTERFACE	16	18	ABSOLUTE MAXIMUM RATINGS	51
7.1	BUS SIGNALS.....	16	19	ELECTRICAL CHARACTERISTICS	52
7.2	BUS TIMING	16	19.1	OPERATIONAL RANGE.....	52
7.3	BUS ARCHITECTURE	17	19.2	DC AND AC SPECIFICATIONS.....	52
7.4	REGISTER WRITE COMMANDS.....	18	19.3	THERMAL CHARACTERISTICS	55
7.5	DRIVER CONTROL REGISTER (DRVCTRL)	20	20	PACKAGE MECHANICAL DATA	56
7.6	CHOPPER CONTROL REGISTER (CHOPCONF)..	22	20.1	DIMENSIONAL DRAWINGS.....	56
7.7	COOLSTEP CONTROL REGISTER (SMARTEN)...	23	20.2	PACKAGE CODE	56
7.8	STALLGUARD2 CONTROL REGISTER (SGCSCONF)	24	21	DISCLAIMER	57
7.9	DRIVER CONTROL REGISTER (DRVCONF) ...	25	22	ESD SENSITIVE DEVICE	57
7.10	READ RESPONSE	26	23	DESIGNED FOR SUSTAINABILITY	57
7.11	DEVICE INITIALIZATION	27	24	TABLE OF FIGURES	58
8	STEP/DIR INTERFACE	28	25	REVISION HISTORY	58
8.1	TIMING	28	26	REFERENCES	58
8.2	MICROSTEP TABLE	29			
8.3	CHANGING RESOLUTION	30			
8.4	MICROPLYER STEP INTERPOLATOR.....	30			
8.5	STANDSTILL CURRENT REDUCTION.....	31			
9	CURRENT SETTING	32			
9.1	SENSE RESISTORS	33			
10	CHOPPER OPERATION	34			
10.1	SPREADCYCLE CHOPPER	35			
10.2	CONSTANT OFF-TIME MODE	38			
11	POWER MOSFET STAGE	40			
11.1	BREAK-BEFORE-MAKE LOGIC.....	40			

1 Principles of Operation

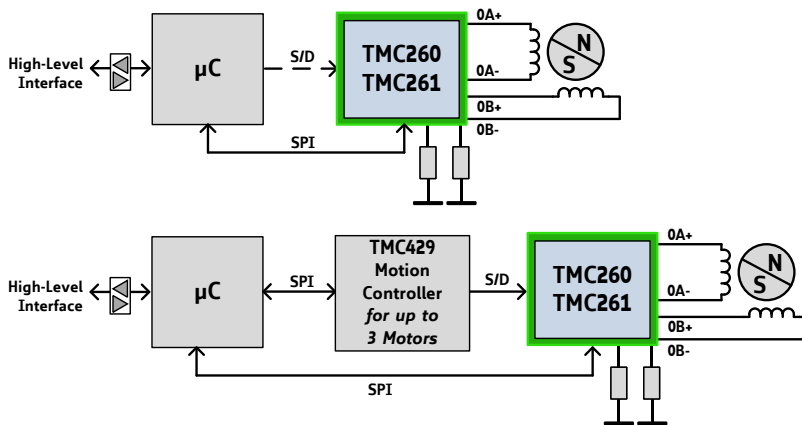

Figure 1.1 applications block diagram

The TMC260 and the TMC261 motor driver chips with included MOSFETs are intelligence and power between a motion controller and the two-phase stepper motor as shown in Figure 1.1. Following power-up, an embedded microcontroller initializes the driver by sending commands over an SPI bus to write control parameters and mode bits in the TMC260/TMC261. The microcontroller may implement the motion-control function as shown in the upper part of the figure, or it may send commands to a dedicated motion controller chip such as TRINAMIC's TMC429 as shown in the lower part.

The motion controller can control the motor position by sending pulses on the STEP signal while indicating the direction on the DIR signal. The TMC260/TMC261 has a microstep counter and sine table to convert these signals into the coil currents which control the position of the motor. If the microcontroller implements the motion-control function, it can write values for the coil currents directly to the TMC260/261 over the SPI interface, in which case the STEP/DIR interface may be disabled. This mode of operation requires software to track the motor position and reference a sine table to calculate the coil currents.

To optimize power consumption and heat dissipation, software may also adjust CoolStep and StallGuard2 parameters in real-time, for example to implement different tradeoffs between speed and power consumption in different modes of operation.

The motion control function is a hard real-time task which may be a burden to implement reliably alongside other tasks on the embedded microcontroller. By offloading the motion-control function to the TMC429, up to three motors can be operated reliably with very little demand for service from the microcontroller. Software only needs to send target positions, and the TMC429 generates precisely timed step pulses. Software retains full control over both the TMC260/TMC261 and TMC429 through the SPI bus.

1.1 Key Concepts

The TMC260 and TMC261 motor drivers implement several advanced features which are exclusive to TRINAMIC products. These features contribute toward greater precision, greater energy efficiency, higher reliability, smoother motion, and cooler operation in many stepper motor applications.

- StallGuard2™** High-precision load measurement using the back EMF on the coils
- CoolStep™** Load-adaptive current control which reduces energy consumption by as much as 75%
- spreadCycle™** High-precision chopper algorithm available as an alternative to the traditional constant off-time algorithm
- MicroPlyer™** Microstep interpolator for obtaining increased smoothness of microstepping over a STEP/DIR interface

In addition to these performance enhancements, TRINAMIC motor drivers also offer safeguards to detect and protect against shorted outputs, open-circuit output, overtemperature, and undervoltage conditions for enhancing safety and recovery from equipment malfunctions.

1.2 Control Interfaces

There are two control interfaces from the motion controller to the motor driver: the SPI serial interface and the STEP/DIR interface. The SPI interface is used to write control information to the chip and read back status information. This interface must be used to initialize parameters and modes necessary to enable driving the motor. This interface may also be used for directly setting the currents flowing through the motor coils, as an alternative to stepping the motor using the STEP and DIR signals, so the motor can be controlled through the SPI interface alone.

The STEP/DIR interface is a traditional motor control interface available for adapting existing designs to use TRINAMIC motor drivers. Using only the SPI interface requires slightly more CPU overhead to look up the sine tables and send out new current values for the coils.

1.2.1 SPI Interface

The SPI interface is a bit-serial interface synchronous to a bus clock. For every bit sent from the bus master to the bus slave, another bit is sent simultaneously from the slave to the master. Communication between an SPI master and the TMC260 or TMC261 slave always consists of sending one 20-bit command word and receiving one 20-bit status word.

The SPI command rate typically corresponds to the microstep rate at low velocities. At high velocities, the rate may be limited by CPU bandwidth to 10-100 thousand commands per second, so the application may need to change to fullstep resolution.

1.2.2 STEP/DIR Interface

The STEP/DIR interface is enabled by default. Active edges on the STEP input can be rising edges or both rising and falling edges, as controlled by another mode bit (DEDGE). Using both edges cuts the toggle rate of the STEP signal in half, which is useful for communication over slow interfaces such as optically isolated interfaces.

On each active edge, the state sampled from the DIR input determines whether to step forward or back. Each step can be a fullstep or a microstep, in which there are 2, 4, 8, 16, 32, 64, 128, or 256 microsteps per fullstep. During microstepping, a step impulse with a low state on DIR increases the microstep counter and a high decreases the counter by an amount controlled by the microstep resolution. An internal table translates the counter value into the sine and cosine values which control the motor current for microstepping.

1.3 Mechanical Load Sensing

The TMC260 and TMC261 provide StallGuard2 high-resolution load measurement for determining the mechanical load on the motor by measuring the back EMF. In addition to detecting when a motor stalls, this feature can be used for homing to a mechanical stop without a limit switch or proximity detector. The CoolStep power-saving mechanism uses StallGuard2 to reduce the motor current to the minimum motor current required to meet the actual load placed on the motor.

1.4 Current Control

Current into the motor coils is controlled using a cycle-by-cycle chopper mode. Two chopper modes are available: a traditional constant off-time mode and the new spreadCycle mode. spreadCycle mode offers smoother operation and greater power efficiency over a wide range of speed and load.

2 Pin Assignments

2.1 Package Outline

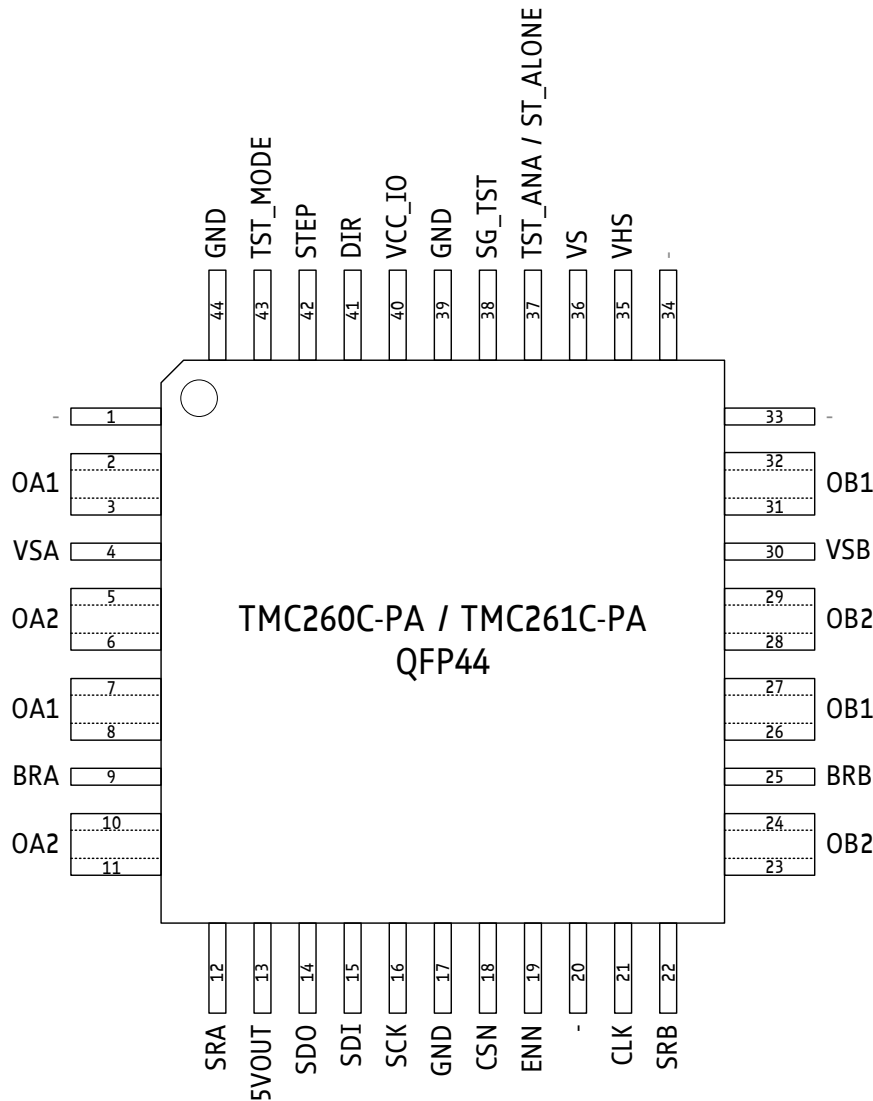

Figure 2.1 TMC260/261 pin assignments (top view)

2.2 Signal Descriptions

Pin	Number	Type	Function
OA1	2, 3 7, 8	O (VS)	Bridge A1 output. Interconnect all of these pins using thick traces capable to carry the motor current and distribute heat into the PCB.
OA2	5, 6 10, 11	O (VS)	Bridge A2 output. Interconnect all of these pins using thick traces capable to carry the motor current and distribute heat into the PCB.
OB1	26, 27 31, 32	O (VS)	Bridge B1 output. Interconnect all of these pins using thick traces capable to carry the motor current and distribute heat into the PCB.
OB2	23, 24 28, 29	O (VS)	Bridge B2 output. Interconnect all of these pins using thick traces capable to carry the motor current and distribute heat into the PCB.
VSA VSB	4 30		Bridge A/B positive power supply. Connect to VS and provide sufficient filtering capacity for chopper current ripple.
BRA BRB	9 25	AI	Bridge A/B negative power supply via sense resistor in bridge foot point.

Pin	Number	Type	Function
SRA SRB	12 22	AI	Sense resistor inputs for chopper current regulation.
5VOUT	13		Output of the on-chip 5V linear regulator. This voltage is used to supply the low-side MOSFETs and internal analog circuitry. An external capacitor to GND close to the pin is required. Place the capacitor near pins 13 and 17. A 470nF ceramic capacitor is sufficient.
SDO	14	DO VIO	SPI serial data output.
SDI (CFG3)	15	DI VIO	Data input of SPI interface / Microstep resolution control input in standalone mode: 0: MRES=256 microsteps; 1: MRES=16 microsteps with interpolation
SCK (CFG2)	16	DI VIO	Serial clock input of SPI interface / Chopper hysteresis control input in standalone mode: 0: HEND=4, HSTRT=2; 1: HEND=4, HSTRT=6
GND	17, 39, 44		Digital and analog low power GND.
CSN (CFG1)	18	DI VIO	Chip select input of SPI interface / Current control input in standalone mode: 0: Current scale CS=15; 1: Current scale CS=31
ENN	19	DI VIO	Power MOSFET enable input. All MOSFETs are switched off when disabled. (Active low.)
CLK	21	DI VIO	System clock input for all internal operations. Tie low to use the on-chip oscillator. A high signal disables the on-chip oscillator until power down.
VHS	35		High-side supply voltage (motor supply voltage - 10V)
VS	36		Motor supply voltage
TST_ANA / ST_ALONE	37	AO/ DI VIO (pd)	non-C-Type: Leave open for normal operation. C-Type only: Tie to VCC_IO for non-SPI, stand-alone mode. Internal 10k pulldown resistor.
SG_TST	38	DO VIO	StallGuard2 output. Signals a motor stall. (Active high.)
VCC_IO	40		Input/output supply voltage VIO for all digital pins. Tie to digital logic supply voltage. Operation is allowed in 3.3V and 5V systems.
DIR	41	DI VIO	Direction input. Sampled on an active edge of the STEP input to determine stepping direction. Sampling a low level increases the microstep counter, while sampling a high decreases the counter. A 60-ns internal glitch filter rejects short pulses on this input.
STEP	42	DI VIO	Step input. Active edges can be rising or both rising and falling, as controlled by the DEDGE mode bit. A 60-ns internal glitch filter rejects short pulses on this input.
TST_MODE	43	DI VIO	Test mode input. Puts IC into test mode. Tie to GND for normal operation.
n.c.	1, 33		No internal connection - can be tied to any net, e.g., in order to improve power routing to pins VSA and VSB.
n.c.	20, 34		No internal connection

3 Internal Architecture

Figure 3.1 shows the internal architecture of TMC260 and TMC261.

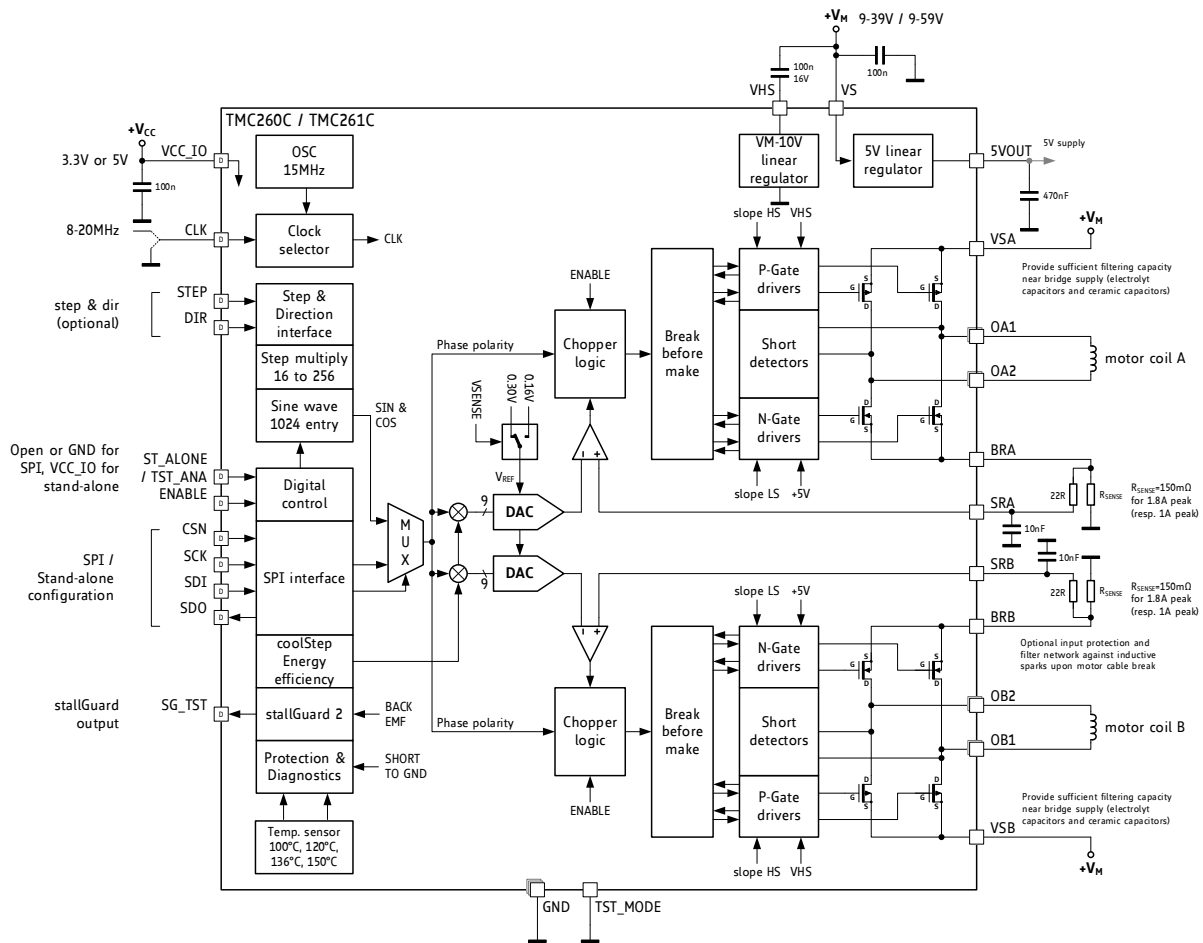

Figure 3.1 TMC260 and TMC261 block diagram

PROMINENT FEATURES INCLUDE:

<i>Oscillator and clock selector</i>	provide the system clock from the on-chip oscillator or an external source.
<i>Step and direction interface</i>	uses a microstep counter and sine table to generate target currents for the coils.
<i>SPI interface</i>	configures current setting, and chopper and optionally receives commands that directly set the coil current values.
<i>Multiplexer</i>	selects either the output of the sine table or the SPI interface for controlling the current into the motor coils.
<i>Multipliers</i>	scale down the currents to both coils when the currents are greater than those required by the load on the motor or as set by the CS current scale parameter.
<i>DACs and comparators</i>	convert the digital current values to analog signals that are compared with the voltages on the sense resistors. Comparator outputs terminate chopper drive phases when target currents are reached.
<i>Break-before-make and gate drivers</i>	ensure non-overlapping pulses, boost pulse voltage, and control pulse slope to the gates of the power MOSFETs.
<i>On-chip voltage regulators</i>	provide high-side voltage for P-channel MOSFET gate drivers and supply voltage for on-chip analog and digital circuits.

4 Standalone Operation

Standalone operation is the easiest way to use the IC. In this mode, three pins configure for the most common settings. Just use the standard application circuit, tie low / high the SPI input pins to set the desired basic operation parameters and choose a sense resistor to fit the required motor current. However, advanced configuration and access to individual diagnostics only is possible via SPI.

CSN: SELECTION OF MOTOR CURRENT (USE FOR STANDSTILL CURRENT REDUCTION)	
CSN (CFG1)	Chopper Setting
GND	Current Scale CS=15. Use for standstill current reduction, or to adapt lower sense resistor value.
VCC_IO	Current Scale CS=31. Maximum current. Control motor current by adapting sense resistors.

SCK: SELECTION OF CHOPPER HYSTERESIS (ADAPT FOR LOWEST MOTOR NOISE & VIBRATION)	
SCK (CFG2)	Chopper Setting
GND	Low hysteresis (HSTRT=2, HEND=4), use for larger motor.
VCC_IO	Medium hysteresis (HSTRT=6, HEND=4), typical for Nema17 or smaller motor, or for high-speed motors with high coil currents.

SDI: SELECTION OF MICROSTEP RESOLUTION (ADAPT TO STEP PULSE GENERATOR)	
SDI (CFG3)	Chopper Setting
GND	256 Microsteps full resolution for Step/Dir interface
VCC_IO	16 Microsteps with internal interpolation to 256 microsteps

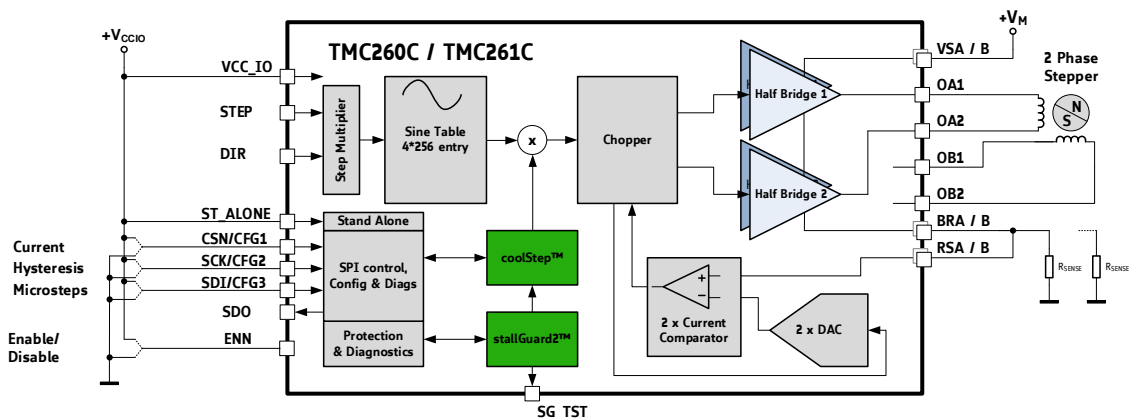

Figure 2 Standalone configuration

Standalone mode automatically enables resonance dampening (EN_PFD) and 136°C overtemperature detection (OT_SENSE), sensitive high-side short detection (SHRTSENSE) and enable low side short protection (S2VS). Driver strength becomes set to SLPL=SLPH=3. TOFF is 4, TBL is 36 clocks in this mode. All other bits are cleared to 0.

In standalone configuration, StallGuard level is fixed to SGT=2. This setting will work for homing with many 42mm and larger motors in a suitable velocity range. Adapt to full or half current as fitting using CSN configuration pin.

Resulting configuration words:
 SDI=0: \$00200 / SDI=1: \$00204
 SCK=0: \$90224 / SCK=1: \$90264
 CSN=0: \$C020F / CSN=1: \$C021F
 \$E810F, \$A0000

5 StallGuard2 Load Measurement

StallGuard2 provides an accurate measurement of the load on the motor. It can be used for stall detection as well as other uses at loads below those which stall the motor, such as CoolStep load-adaptive current reduction. (StallGuard2 is a more precise evolution of the earlier StallGuard technology.)

The StallGuard2 measurement value changes linearly over a wide range of load, velocity, and current settings, as shown in Figure 5.1. At maximum motor load, the value goes to zero or near to zero. This corresponds to a load angle of 90° between the magnetic field of the coils and magnets in the rotor. This also is the most energy-efficient point of operation for the motor.

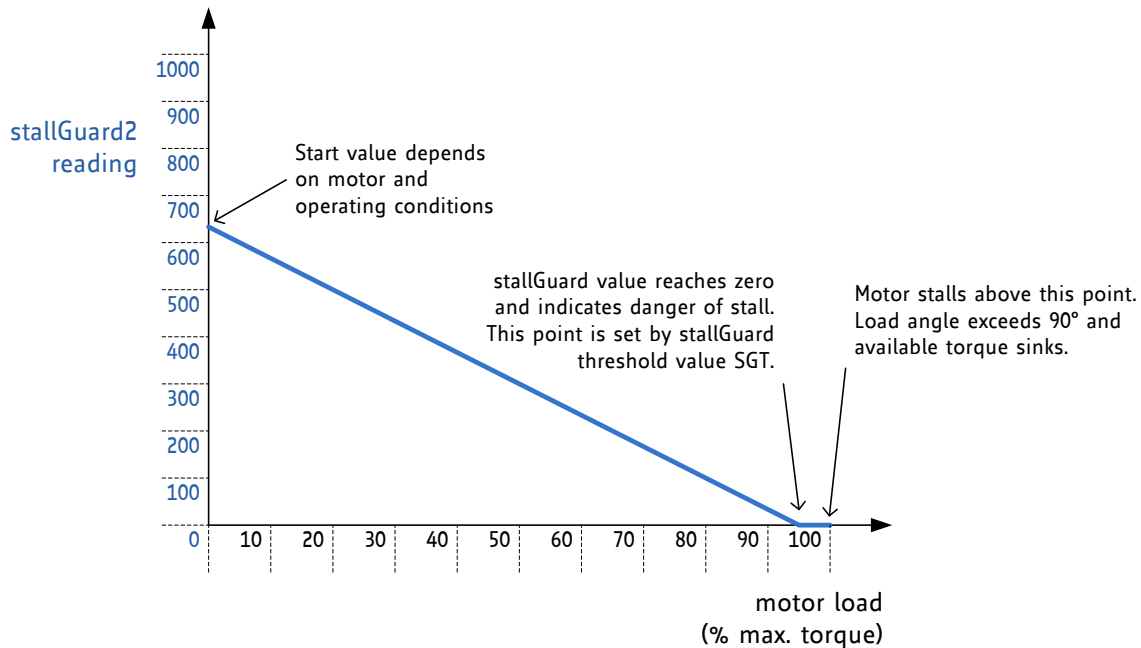

Figure 5.1 StallGuard2 load measurement SG as a function of load

Two parameters control StallGuard2 and one status value is returned.

Parameter	Description	Setting	Comment
SGT	7-bit signed integer that sets the StallGuard2 threshold level for asserting the SG_TST output and sets the optimum measurement range for readout. Negative values increase sensitivity, and positive values reduce sensitivity, so more torque is required to indicate a stall. Zero is a good starting value.	0	indifferent value
		+1... +63	less sensitivity
		-1... -64	higher sensitivity
SFILT	Mode bit which enables the StallGuard2 filter for more precision. If set, reduces the measurement frequency to one measurement per four fullsteps. If cleared, no filtering is performed. Filtering compensates for mechanical asymmetries in the construction of the motor, but at the expense of response time. Unfiltered operation is recommended for rapid stall detection. Filtered operation is recommended for more precise load measurement.	0	standard mode
		1	filtered mode

Status word	Description	Range	Comment
SG	10-bit unsigned integer StallGuard2 measurement value. A higher value indicates lower mechanical load. A lower value indicates a higher load and therefore a higher load angle. For stall detection, adjust SGT to return an SG value of 0 or slightly higher upon maximum motor load before stall.	0... 1023	0: highest load low value: high load high value: less load

5.1 Tuning the StallGuard2 Threshold

Due to the dependency of the StallGuard2 value SG from motor-specific characteristics and application-specific demands on load and velocity the easiest way to tune the StallGuard2 threshold *SGT* for a specific motor type and operating conditions is interactive tuning in the actual application.

The procedure is:

1. Operate the motor at a reasonable velocity for your application and monitor SG.
2. Apply slowly increasing mechanical load to the motor. If the motor stalls before SG reaches zero, decrease SGT. If SG reaches zero before the motor stalls, increase SGT. A good SGT starting value is zero. SGT is signed, so it can have negative or positive values.
3. The optimum setting is reached when SG is between 0 and 400 at increasing load shortly before the motor stalls, and SG increases by 100 or more without load. SGT in most cases can be tuned together with the motion velocity in a way that SG goes to zero when the motor stalls and the stall output SG_TST is asserted. This indicates that a step has been lost.

The system clock frequency affects SG. An external crystal-stabilized clock should be used for applications that demand the highest precision. The power supply voltage also affects SG, so tighter regulation results in more accurate values. SG measurement has a high resolution, and there are a few ways to enhance its accuracy, as described in the following sections.

5.1.1 Variable Velocity Operation

Across a range of velocities, on-the-fly adjustment of the StallGuard2 threshold SGT improves the accuracy of the load measurement SG. This also improves the power reduction provided by CoolStep, which is driven by SG. Linear interpolation between two SGT values optimized at different velocities is a simple algorithm for obtaining most of the benefits of on-the-fly SGT adjustment, as shown in Figure 5.2. An optimal SGT curve in black and a two-point interpolated SGT curve in red are shown.

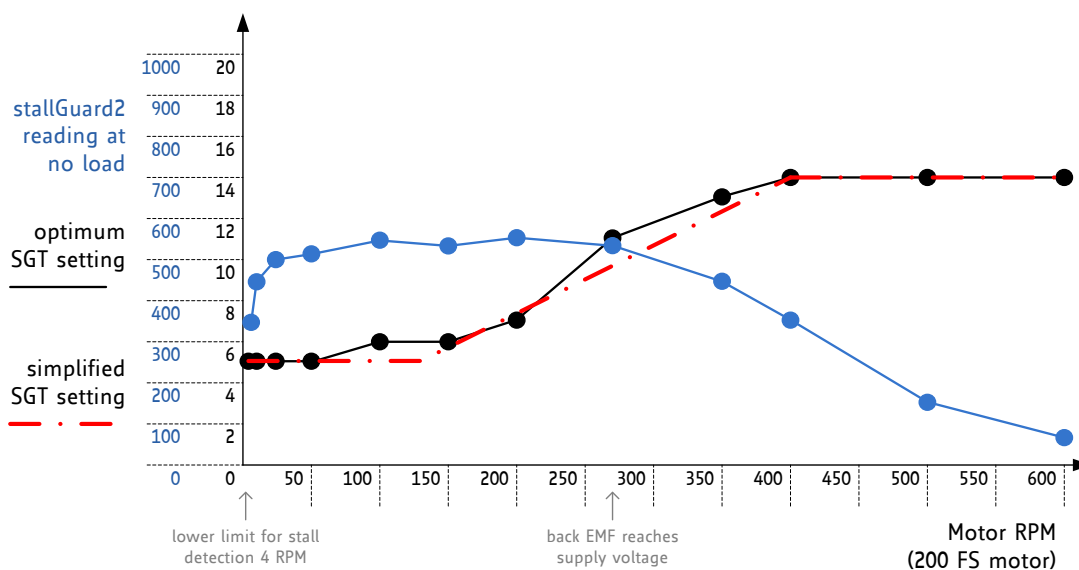

Figure 5.2 Linear interpolation for optimizing SGT with changes in velocity.

5.1.2 Small Motors with High Torque Ripple and Resonance

Motors with a high detent torque show an increased variation of the StallGuard2 measurement value SG with varying motor currents, especially at low currents. For these motors, the current dependency might need correction in a similar manner to velocity correction for obtaining the highest accuracy.

5.1.3 Temperature Dependence of Motor Coil Resistance

Motors working over a wide temperature range may require temperature correction, because motor coil resistance increases with rising temperature. This can be corrected as a linear reduction of SG at increasing temperature, as motor efficiency is reduced.

5.1.4 Accuracy and Reproducibility of StallGuard2 Measurement

In a production environment, it may be desirable to use a fixed SGT value within an application for one motor type. Most of the unit-to-unit variation in StallGuard2 measurements results from manufacturing tolerances in motor construction. The measurement error of StallGuard2 – provided that all other parameters remain stable – can be as low as:

$$\text{stallGuard measurement error} = \pm \max(1, |SGT|)$$

5.2 StallGuard2 Measurement Frequency and Filtering

The StallGuard2 measurement value SG is updated with each full step of the motor. This is enough to safely detect a stall, because a stall always means the loss of four full steps. In a practical application, especially when using CoolStep, a more precise measurement might be more important than an update for each fullstep because the mechanical load never changes instantaneously from one step to the next. For these applications, the SFILT bit enables a filtering function over four load measurements. The filter should always be enabled when high-precision measurement is required. It compensates for variations in motor construction, for example due to misalignment of the phase A to phase B magnets. The filter should only be disabled when rapid response to increasing load is required, such as for stall detection at high velocity.

5.3 Detecting a Motor Stall

To safely detect a motor stall, a stall threshold must be determined using a specific SGT setting. Therefore, you need to determine the maximum load the motor can drive without stalling and to monitor the SG value at this load, for example some value within the range 0 to 400. The stall threshold should be a value safely within the operating limits, to allow for parameter stray. So, your microcontroller software should set a stall threshold which is slightly higher than the minimum value seen before an actual motor stall occurs. The response at an SGT setting at or near 0 gives some idea on the quality of the signal: Check the SG value without load and with maximum load. These values should show a difference of at least 100 or a few 100, which shall be large compared to the offset. If you set the SGT value so that a reading of 0 occurs at maximum motor load, an active high stall output signal will be available at SG_TST output.

5.4 Limits of StallGuard2 Operation

StallGuard2 does not operate reliably at extreme motor velocities: Very low motor velocities (for many motors, less than one revolution per second) generate a low back EMF and make the measurement instable and dependent on environment conditions (temperature, etc.). Other conditions will also lead to extreme settings of SGT and poor response of the measurement value SG to the motor load.

Very high motor velocities, in which the full sinusoidal current is not driven into the motor coils also lead to poor response. These velocities are typically characterized by the motor back EMF reaching the supply voltage.

6 CoolStep Load-Adaptive Current Control

CoolStep allows substantial energy savings, especially for motors which see varying loads or operate at a high duty cycle. Because a stepper motor application needs to work with a torque reserve of 30% to 50%, even a constant-load application allows significant energy savings because CoolStep automatically enables torque reserve when required. Reducing power consumption keeps the system cooler, increases motor life, and allows reducing cost in the power supply and cooling components.

Hint

Reducing motor current by half results in reducing power by a factor of four.

- Energy efficiency* - power consumption decreased up to 75%.
- Motor generates less heat* - improved mechanical precision.
- Less cooling infrastructure* - for motor and driver.
- Cheaper motor* - does the job.

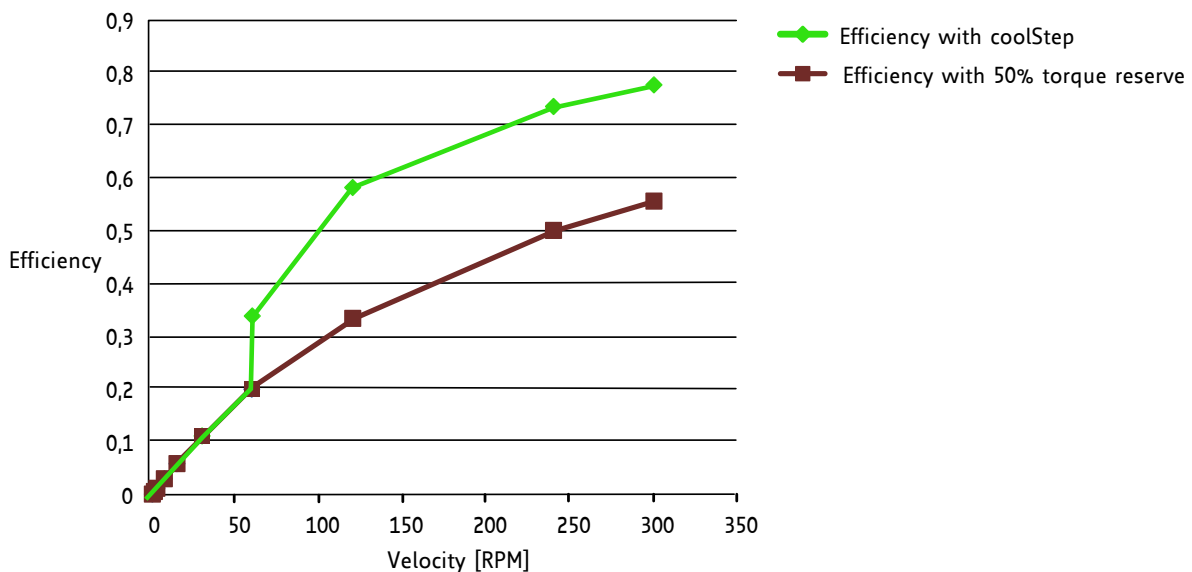

Figure 6.1 Energy efficiency example with CoolStep

Figure 6.1 shows the efficiency gain of a 42mm stepper motor when using CoolStep compared to standard operation with 50% of torque reserve. CoolStep is enabled above 60rpm in the example.

CoolStep is controlled by several parameters, but two are critical for understanding how it works:

Parameter	Description	Range	Comment
SEMIN	4-bit unsigned integer that sets a lower threshold. If SG goes below this threshold, CoolStep increases the current to both coils. The 4-bit SEMIN value is scaled by 32 to cover the lower half of the range of the 10-bit SG value. (The name of this parameter is derived from smartEnergy, which is an earlier name for CoolStep.)	0... 15	lower CoolStep threshold: SEMINx32
SEMAX	4-bit unsigned integer that controls an upper threshold. If SG is sampled equal to or above this threshold enough times, CoolStep decreases the current to both coils. The upper threshold is $(SEMIN + SEMAX + 1) \times 32$.	0... 15	upper CoolStep threshold: $(SEMIN+SEMAX+1) \times 32$

Figure 6.2 shows the operating regions of CoolStep. The black line represents the SG measurement value, the blue line represents the mechanical load applied to the motor, and the red line represents

the current into the motor coils. When the load increases, SG falls below SEMIN, and CoolStep increases the current. When the load decreases and SG rises above (SEMAX + SEMIN + 1) x 32 the current becomes reduced.

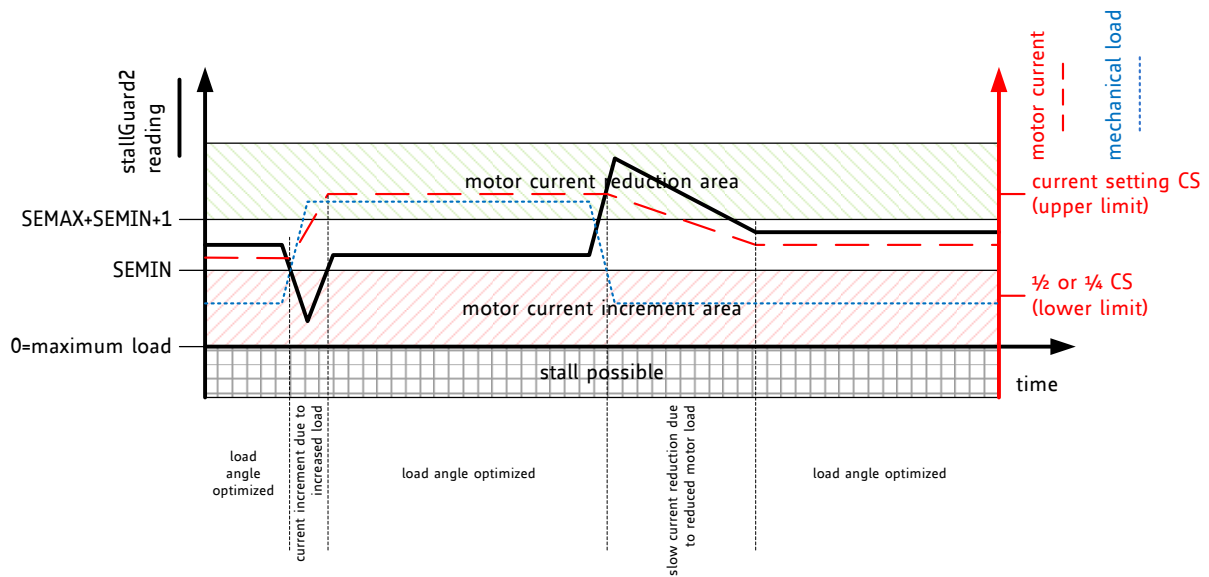

Figure 6.2 CoolStep adapts motor current to the load.

Four more parameters control CoolStep and one status value is returned:

Parameter	Description	Range	Comment
CS	Current scale. Scales both coil current values as taken from the internal sine wave table or from the SPI interface. For high precision motor operation, work with a current scaling factor in the range 16 to 31, because scaling down the current values reduces the effective microstep resolution by making microsteps coarser. This setting also controls the maximum current value set by CoolStep™.	0.. 31	scaling factor: 1/32, 2/32, ... 32/32
SEUP	Number of increments of the coil current for each occurrence of an SG measurement below the lower threshold.	0.. 3	step width is: 1, 2, 4, 8
SEDN	Number of occurrences of SG measurements above the upper threshold before the coil current is decremented.	0.. 3	number of StallGuard measurements per decrement: 32, 8, 2, 1
SEIMIN	Mode bit that controls the lower limit for scaling the coil current. If the bit is set, the limit is 1/4 CS. If the bit is clear, the limit is 1/2 CS.	0	Minimum motor current: 1/2 of CS
		1	1/4 of CS
Status word	Description	Range	Comment
SE	5-bit unsigned integer reporting the actual current scaling value determined by CoolStep. This value is biased by 1 and divided by 32, so the range is 1/32 to 32/32. The value will not be greater than the value of CS or lower than either 1/4 CS or 1/2 CS depending on SEIMIN setting.	0.. 31	Actual motor current scaling factor set by CoolStep: 1/32, 2/32, ... 32/32

6.1 Tuning CoolStep

Before tuning CoolStep, first tune the StallGuard2 threshold level SGT, which affects the range of the load measurement value SG. CoolStep uses SG to operate the motor near the optimum load angle of +90°.

The current increment speed is specified in SEUP, and the current decrement speed is specified in SEDN. They can be tuned separately because they are triggered by different events that may need different responses. The encodings for these parameters allow the coil currents to be increased much more quickly than decreased, because crossing the lower threshold is a more serious event that may require a faster response. If the response is too slow, the motor may stall. In contrast, a slow response to crossing the upper threshold does not risk anything more serious than missing an opportunity to save power.

Hint

CoolStep operates between limits controlled by the current scale parameter CS and the SEIMIN bit.

6.1.1 Response Time

For fast response to increasing motor load, use a high current increment step SEUP. If the motor load changes slowly, a lower current increment step can be used to avoid motor current oscillations. If the filter controlled by SFILT is enabled, the measurement rate and regulation speed are cut by a factor of four.

6.1.2 Low Velocity and Standby Operation

Because StallGuard2 is not able to measure the motor load in standstill and at very low RPM, the current at low velocities should be set to an application-specific default value and combined with standstill current reduction settings programmed through the SPI interface.

7 SPI Interface

The TMC260 and TMC261 allow full control over all configuration parameters and mode bits through the SPI interface. An initialization is required prior to motor operation. The SPI interface also allows reading back status values and bits.

7.1 Bus Signals

The SPI bus on the TMC260 and the TMC261 has four signals:

SCK	bus clock input
SDI	serial data input
SDO	serial data output
CSN	chip select input (active low)

The slave is enabled for an SPI transaction by a low on the chip select input CSN. Bit transfer is synchronous to the bus clock SCK, with the slave latching the data from SDI on the rising edge of SCK and driving data to SDO following the falling edge. The most significant bit is sent first. A minimum of 20 SCK clock cycles is required for a bus transaction with the TMC260 and the TMC261.

If more than 20 clocks are driven, the additional bits shifted into SDI are shifted out on SDO after a 20-clock delay through an internal shift register. This can be used for daisy chaining multiple chips.

CSN must be low during the whole bus transaction. When CSN goes high, the contents of the internal shift register are latched into the internal control register and recognized as a command from the master to the slave. If more than 20 bits are sent, only the last 20 bits received before the rising edge of CSN are recognized as the command.

7.2 Bus Timing

SPI interface is synchronized to the internal system clock, which limits the SPI bus clock SCK to half of the system clock frequency. If the system clock is based on the on-chip oscillator, an additional 10% safety margin must be used to ensure reliable data transmission. All SPI inputs as well as the ENN input are internally filtered to avoid triggering on pulses shorter than 20ns. Figure 7.1 shows the timing parameters of an SPI bus transaction, and the table below specifies their values.

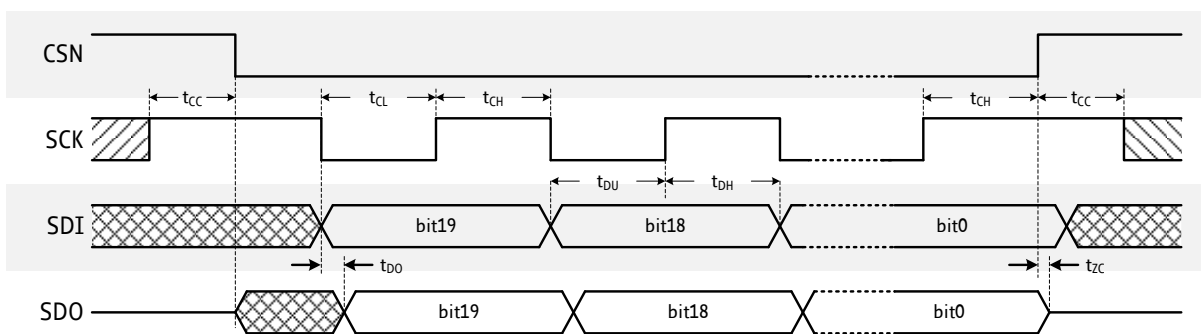

Figure 7.1 SPI Timing

Hint

Usually, this SPI timing is referred to as SPI MODE 3. Data change is at the negative SCK edge, and SCK return to high level. CSN spans the complete 20 Bit transmission, or 24 Bit, filled with dummy bits in the MSBs.

SPI Interface Timing		AC-Characteristics				
		clock period is t_{CLK}				
Parameter	Symbol	Conditions	Min	Typ	Max	Unit
SCK valid before or after change of CSN	t_{CC}		10			ns
CSN high time	t_{CSH}	^{*)} Min time is for synchronous CLK with SCK high one t_{CH} before CSN high only	t_{CLK}	$>2t_{CLK} + 10$		ns
SCK low time	t_{CL}	^{*)} Min time is for synchronous CLK only	t_{CLK}	$>t_{CLK} + 10$		ns
SCK high time	t_{CH}	^{*)} Min time is for synchronous CLK only	t_{CLK}	$>t_{CLK} + 10$		ns
SCK frequency using internal clock	f_{SCK}	Assumes minimum OSC frequency			4	MHz
SCK frequency using external 16MHz clock	f_{SCK}	Assumes synchronous CLK			8	MHz
SDI setup time before rising edge of SCK	t_{DU}		10			ns
SDI hold time after rising edge of SCK	t_{DH}		10			ns
Data out valid time after falling SCK clock edge	t_{DO}	No capacitive load on SDO			$t_{FILT} + 5$	ns
SDI, SCK, and CSN filter delay time	t_{FILT}	Rising and falling edge	12	20	30	ns

7.3 Bus Architecture

SPI slaves can be chained and used with a single chip select line. If slaves are chained, they behave like a long shift register. For example, a chain of two motor drivers requires 40 bits to be sent. The last bits shifted to each register in the chain are loaded into an internal register on the rising edge of the CSN input. For example, 24 or 32 bits can be sent to a single motor driver, but it latches just the last 20 bits received before CSN goes high.

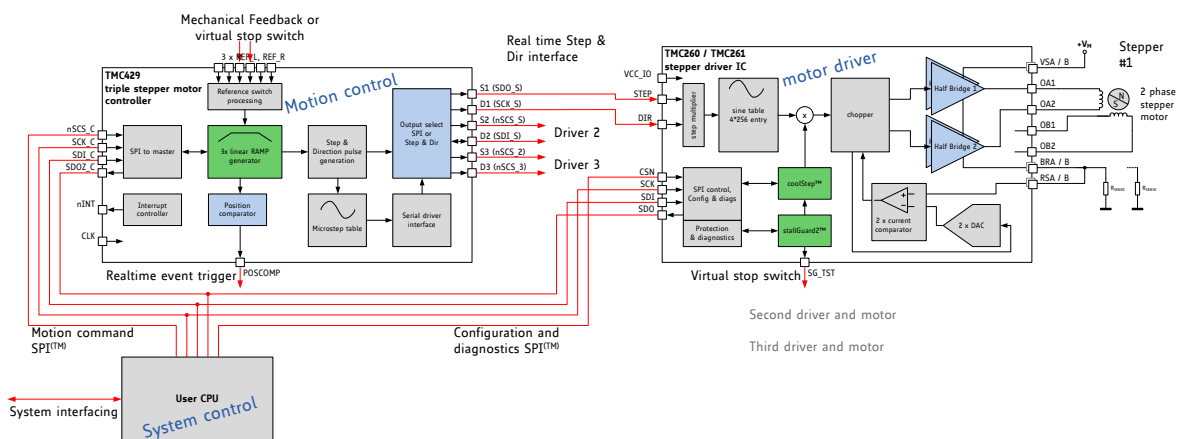

Figure 7.2 Interfaces to a TMC429 motion controller chip and a TMC260 or TMC261 motor driver

Figure 7.2 shows the interfaces in a typical application. The SPI bus is used by an embedded MCU to initialize the control registers of both a motion controller and one or more motor drivers. STEP/DIR interfaces are used between the motion controller and the motor drivers.

7.4 Register Write Commands

An SPI bus transaction to the TMC260 or TMC261 is a write command to one of the five write-only registers that hold configuration parameters and mode bits:

Register	Description
Driver Control Register (DRVCTRL)	The DRVCTRL register has different formats for controlling the interface to the motion controller depending on whether the STEP/DIR interface is enabled.
Chopper Configuration Register (CHOPCONF)	The CHOPCONF register holds chopper parameters and mode bits.
CoolStep Configuration Register (SMARTEN)	The SMARTEN register holds CoolStep parameters and a mode bit. (smartEnergy is an earlier name for CoolStep.)
StallGuard2 Configuration Register (SGCSCONF)	The SGCSCONF register holds StallGuard2 parameters and a mode bit.
Driver Configuration Register (DRVCONF)	The DRVCONF register holds parameters and mode bits used to control the power MOSFETs and the protection circuitry. It also holds the SDOFF bit which controls the STEP/DIR interface and the RDSEL parameter which controls the contents of the response returned in an SPI transaction.

In the following sections, multibit binary values are prefixed with a % sign, for example %0111.

7.4.1 Write Command Overview

The table below shows the formats for the five register write commands. Bits 19, 18, and sometimes 17 select the register being written, as shown in bold. The DRVCTRL register has two formats, as selected by the SDOFF bit. Bits shown as 0 must always be written as 0, and bits shown as 1 must always be written with 1. Detailed descriptions of each parameter and mode bit are given in the following sections.

Register/ Bit	DRVCTRL (SDOFF=1)	DRVCTRL (SDOFF=0)	CHOPCONF	SMARTEN	SGCSCONF	DRVCONF
19	0	0	1	1	1	1
18	0	0	0	0	1	1
17	PHA	0	0	1	0	1
16	CA7	0	TBL1	0	SFILT	TST
15	CA6	0	TBL0	SEIMIN	0	SLPH1
14	CA5	0	CHM	SEDN1	SGT6	SLPH0
13	CA4	0	RNDTF	SEDN0	SGT5	SLPL1
12	CA3	0	HDEC1	0	SGT4	SLPL0
11	CA2	0	HDEC0	SEMAX3	SGT3	0
10	CA1	0	HEND3	SEMAX2	SGT2	DISS2G
9	CA0	INTPOL	HEND2	SEMAX1	SGT1	TS2G1
8	PHB	DEDGE	HEND1	SEMAX0	SGT0	TS2G0
7	CB7	0	HEND0	0	0	SDOFF
6	CB6	0	HSTRT2	SEUP1	0	VSENSE
5	CB5	0	HSTRT1	SEUP0	0	RDSEL1
4	CB4	0	HSTRT0	0	CS4	RDSEL0
3	CB3	MRES3	TOFF3	SEMIN3	CS3	OTSENS *)
2	CB2	MRES2	TOFF2	SEMIN2	CS2	SHRTSENS *)
1	CB1	MRES1	TOFF1	SEMIN1	CS1	EN_PFD *)
0	CB0	MRES0	TOFF0	SEMIN0	CS0	EN_S2VS *)

*) Additional option for -C types only. Setting these bits for non-C-types does not have any effect.

7.4.2 Read Response Overview

The table below shows the formats for the read response. The RDSEL parameter in the DRVCONF register selects the format of the read response.

Bit	RDSEL=%00	RDSEL=%01	RDSEL=%10	RDSEL=%11*)
19	MSTEP9	SG9	SG9	UV_7V
18	MSTEP8	SG8	SG8	ENN input
17	MSTEP7	SG7	SG7	S2VSB
16	MSTEP6	SG6	SG6	S2GB
15	MSTEP5	SG5	SG5	S2VSA
14	MSTEP4	SG4	SE4	S2GA
13	MSTEP3	SG3	SE3	OT150
12	MSTEP2	SG2	SE2	OT136
11	MSTEP1	SG1	SE1	OT120
10	MSTEP0	SG0	SE0	OT100
9	0	0	0	1
8	0	0	0	1
7	STST			
6	OLB			
5	OLA			
4	SHORTB (S2GB for non-C-type)			
3	SHORTA (S2GA for non-C-type)			
2	OTPW			
1	OT			
0	SG			

7.5 Driver Control Register (DRVCTRL)

The format of the DRVCTRL register depends on the state of the SDOFF mode bit.

SPI Mode SDOFF bit is set, the STEP/DIR interface is disabled, and DRVCTRL is the interface for specifying the currents through each coil.

STEP/DIR Mode SDOFF bit is clear, the STEP/DIR interface is enabled, and DRVCTRL is a configuration register for the STEP/DIR interface.

7.5.1 DRVCTRL Register in SPI Mode

DRVCTRL		Driver Control in SPI Mode (SDOFF=1)	
Bit	Name	Function	Comment
19	0	Register address bit	
18	0	Register address bit	
17	PHA	Polarity A	Sign of current flow through coil A: 0: Current flows from OA1 pins to OA2 pins. 1: Current flows from OA2 pins to OA1 pins.
16	CA7	Current A MSB	Magnitude of current flow through coil A. The range is 0 to 248, if hysteresis or offset are used up to their full extent. The resulting value after applying hysteresis or offset must not exceed 255.
15	CA6		
14	CA5		
13	CA4		
12	CA3		
11	CA2		
10	CA1		
9	CA0	Current A LSB	
8	PHB	Polarity B	Sign of current flow through coil B: 0: Current flows from OB1 pins to OB2 pins. 1: Current flows from OB2 pins to OB1 pins.
7	CB7	Current B MSB	Magnitude of current flow through coil B. The range is 0 to 248, if hysteresis or offset are used up to their full extent. The resulting value after applying hysteresis or offset must not exceed 255.
6	CB6		
5	CB5		
4	CB4		
3	CB3		
2	CB2		
1	CB1		
0	CB0	Current B LSB	

7.5.2 DRVCTRL Register in STEP/DIR Mode

DRVCTRL		Driver Control in STEP/DIR Mode (SDOFF=0)	
Bit	Name	Function	Comment
19	0	Register address bit	
18	0	Register address bit	
17	0	Reserved	
16	0	Reserved	
15	0	Reserved	
14	0	Reserved	
13	0	Reserved	
12	0	Reserved	
11	0	Reserved	
10	0	Reserved	
9	INTPOL	Enable STEP interpolation	0: Disable STEP pulse interpolation. 1: Enable STEP pulse multiplication by 16.
8	DEDGE	Enable double edge STEP pulses	0: Rising STEP pulse edge is active, falling edge is inactive. 1: Both rising and falling STEP pulse edges are active.
7	0	Reserved	
6	0	Reserved	
5	0	Reserved	
4	0	Reserved	
3	MRES3	Microstep resolution for STEP/DIR mode	Microsteps per 90°: %0000: 256 %0001: 128 %0010: 64 %0011: 32 %0100: 16 %0101: 8 %0110: 4 %0111: 2 (halfstep) %1000: 1 (fullstep)
2	MRES2		
1	MRES1		
0	MRES0		

7.6 Chopper Control Register (CHOPCONF)

CHOPCONF		Chopper Configuration	
Bit	Name	Function	Comment
19	1	Register address bit	
18	0	Register address bit	
17	0	Register address bit	
16	TBL1	Blanking time	Blanking time interval, in system clock periods: %00: 16 %01: 24 %10: 36 %11: 54
15	TBL0		
14	CHM	Chopper mode	This mode bit affects the interpretation of the HDEC, HEND, and HSTRT parameters shown below. 0 Standard mode (SpreadCycle) 1 Constant t_{OFF} with fast decay time. Fast decay time is also terminated when the negative nominal current is reached. Fast decay is after on time.
13	RNDTF	Random TOFF time	Enable randomizing the slow decay phase duration: 0: Chopper off time is fixed as set by bits t_{OFF} 1: Random mode, t_{OFF} is random modulated by $dN_{CLK} = -24 \dots +6$ clocks.
12	HDEC1	Hysteresis decrement interval or Fast decay mode	CHM=0 Hysteresis decrement period setting, in system clock periods: %00: 16 %01: 32 %10: 48 %11: 64
11	HDEC0		CHM=1 HDEC1=0: current comparator can terminate the fast decay phase before timer expires. HDEC1=1: only the timer terminates the fast decay phase. HDEC0: MSB of fast decay time setting.
10	HEND3	Hysteresis end (low) value or Sine wave offset	CHM=0 %0000 ... %1111: Hysteresis is -3, -2, -1, 0, 1, ..., 12 (1/512 of this setting adds to current setting) This is the hysteresis value which becomes used for the hysteresis chopper.
9	HEND2		
8	HEND1		CHM=1 %0000 ... %1111: Offset is -3, -2, -1, 0, 1, ..., 12 This is the sine wave offset and 1/512 of the value becomes added to the absolute value of each sine wave entry.
7	HEND0		
6	HSTRT2	Hysteresis start value or Fast decay time setting	CHM=0 Hysteresis start offset from HEND: %000: 1 %100: 5 %001: 2 %101: 6 %010: 3 %110: 7 %011: 4 %111: 8 <i>Effective: HEND+HSTRT must be ≤ 15</i>
5	HSTRT1		
4	HSTRT0		

CHOPCONF		Chopper Configuration	
Bit	Name	Function	Comment
3	TOFF3	Off time/MOSFET disable	Duration of slow decay phase. If TOFF is 0, the MOSFETs are shut off. If TOFF is nonzero, slow decay time is a multiple of system clock periods: $N_{CLK} = 24 + (32 \times TOFF)$ %0000: Driver disable, all bridges off %0001: 1 (use with TBL of minimum 24 clocks) %0010 ... %1111: 2 ... 15
2	TOFF2		
1	TOFF1		
0	TOFF0		

7.7 CoolStep Control Register (SMARTEN)

SMARTEN		CoolStep Configuration	
Bit	Name	Function	Comment
19	1	Register address bit	
18	0	Register address bit	
17	1	Register address bit	
16	0	Reserved	
15	SEIMIN	Minimum CoolStep current	0: ½ CS current setting 1: ¼ CS current setting
14	SEDN1	Current decrement speed	Number of times that the StallGuard2 value must be sampled equal to or above the upper threshold for each decrement of the coil current: %00: 32 %01: 8 %10: 2 %11: 1
13	SEDN0		
12	0	Reserved	
11	SEMAX3	Upper CoolStep threshold as an offset from the lower threshold	If the StallGuard2 measurement value SG is sampled equal to or above (SEMIN+SEMAX+1) x 32 enough times, then the coil current scaling factor is decremented.
10	SEMAX2		
9	SEMAX1		
8	SEMAX0		
7	0	Reserved	
6	SEUP1	Current increment size	Number of current increment steps for each time that the StallGuard2 value SG is sampled below the lower threshold: %00: 1 %01: 2 %10: 4 %11: 8
5	SEUP0		
4	0	Reserved	
3	SEMIN3	Lower CoolStep threshold/CoolStep disable	If SEMIN is 0, CoolStep is disabled. If SEMIN is nonzero and the StallGuard2 value SG falls below SEMIN x 32, the CoolStep current scaling factor is increased.
2	SEMIN2		
1	SEMIN1		
0	SEMIN0		

7.8 StallGuard2 Control Register (SGCSCONF)

SGCSCONF		StallGuard2™ and Current Setting	
Bit	Name	Function	Comment
19	1	Register address bit	
18	1	Register address bit	
17	0	Register address bit	
16	SFILT	StallGuard2 filter enable	0: Standard mode, fastest response time. 1: Filtered mode, updated once for each four fullsteps to compensate for variation in motor construction, highest accuracy.
15	0	Reserved	
14	SGT6	StallGuard2 threshold value	The StallGuard2 threshold value controls the optimum measurement range for readout and stall indicator output (SG_TST). A lower value results in a higher sensitivity and less torque is required to indicate a stall. The value is a two's complement signed integer. Range: -64 to +63
13	SGT5		
12	SGT4		
11	SGT3		
10	SGT2		
9	SGT1		
8	SGT0		
7	0	Reserved	
6	0	Reserved	
5	0	Reserved	
4	CS4	Current scale (scales digital currents A and B)	Current scaling for SPI and step/direction operation. %00000 ... %11111: 1/32, 2/32, 3/32, ... 32/32 This value is biased by 1 and divided by 32, so the range is 1/32 to 32/32. Example: CS=20 is 21/32 current
3	CS3		
2	CS2		
1	CS1		
0	CS0		

7.9 Driver Control Register (DRVCONF)

DRVCONF		Driver Configuration	
Bit	Name	Function	Comment
19	1	Register address bit	
18	1	Register address bit	
17	1	Register address bit	
16	TST	Reserved TEST mode	Must be cleared for normal operation. When set, the SG_TST output exposes digital test values, and the TEST_ANA output exposes analog test values.
15	SLPH1	Slope control, high side	%00: Minimum %01: Minimum (+tc) %10: Medium (+tc) %11: Maximum Temperature compensated mode (tc) increases the high-side MOSFET gate driver strength if the overtemperature warning temperature is reached. This compensates for temperature dependency of high-side slope control.
14	SLPH0		
13	SLPL1		
12	SLPL0	Slope control, low side	
11	0	Reserved	Set to 0
10	DISS2G	Short to GND protection disable	0: Short to GND protection is enabled. 1: Short to GND protection is disabled.
9	TS2G1	Short to GND detection timer	%00: 3.2µs. %01: 1.6µs. %10: 1.2µs. %11: 0.8µs.
8	TS2G0		
7	SDOFF	STEP/DIR interface disable	0: Enable STEP and DIR interface. 1: Disable STEP and DIR interface. SPI interface is used to move motor.
6	VSENSE	Sense resistor voltage-based current scaling	0: Full-scale sense resistor voltage is 310mV. 1: Full-scale sense resistor voltage is 165mV. (Full-scale refers to a current setting of 31 and a DAC value of 255.)
5	RDSEL1	Select value for read out (RD bits)	%00 Microstep position read back
4	RDSEL0		%01 StallGuard2 level read back
			%10 StallGuard2 & CoolStep current level read back
			%11 *) All status flags and detectors
3	OTSENS *)	Overtemperature sensitivity	0: Shutdown at 150°C 1: Sensitive shutdown at 136°C
2	SHRTSENS *)	Short to GND detection sensitivity	0: Low sensitivity 1: High sensitivity – better protection for high side FETs
1	EN_PFD *)	Enable Passive fast decay / 5V undervoltage threshold	0: No additional motor dampening. 1: Motor dampening to reduce motor resonance at medium velocity. In addition, this bit reduces the lower nominal operation voltage limit from 7V to 4.5V
0	EN_S2VS *)	Enable short to VS & CLK fail protection	0: Short to VS and clock failsafe protection disabled 1: Short to VS / overcurrent protection enabled. In addition, enables protection against clock input CLK fail, when using an external clock source.

*) These bits have a function for -C types only. Setting these bits / functions for non-C-types does not have any effect. The TMC260 and TMC260C, resp. TMC261 and TMC261C behave identically with setting 0.

7.10 Read Response

For every write command sent to the motor driver, a 20-bit response is returned to the motion controller. The response has one of three formats, as selected by the RDSEL parameter in the DRVCONF register. The table below shows these formats. Software must not depend on the value of any bit shown as reserved.

DRVSTATUS					Read Response	
Bit	Name				Function	Comment
	RDSEL					
	%00	%01	%10	%11		
19	MSTEP9	SG9	SG9	UV_7V	Microstep counter / StallGuard2 SG9:0 / StallGuard2 SG9:5 and CoolStep SE4:0 / Diagnostic status	Microstep position in sine table for coil A in STEP/DIR mode. MSTEP9 is the Polarity bit: 0: Current flows from OA1 pins to OA2 pins. 1: Current flows from OA2 pins to OA1 pins.
18	MSTEP8	SG8	SG8	ENN in		
17	MSTEP7	SG7	SG7	S2VSB		
16	MSTEP6	SG6	SG6	S2GB		
15	MSTEP5	SG5	SG5	S2VSA		
14	MSTEP4	SG4	SE4	S2GA		
13	MSTEP3	SG3	SE3	OT150		
12	MSTEP2	SG2	SE2	OT136		
11	MSTEP1	SG1	SE1	OT120		
10	MSTEP0	SG0	SE0	OT100		
9	0			1	-	%11 response allows to distinguish -C type. Non-C-type delivers %00 in each case.
8	0			1		
7	STST				Standstill indicator	0: No standstill condition detected. 1: No active edge occurred on the STEP input during the last 2 ²⁰ system clock cycles.
6	OLB				Open load indicator	0: No open load condition detected. 1: No chopper event has happened during the last period with constant coil polarity. Only a current above 1/16 of the maximum setting can clear this bit! <i>Hint:</i> This bit is only a status indicator. The chip takes no other action when this bit is set. False indications may occur during fast motion and at standstill. Check this bit only during slow motion.
5	OLA					
4	SHORTB				Short detection status	0: No short condition. 1: Short condition. The short counter is incremented by each short circuit and the chopper cycle is suspended. The counter is decremented for each phase polarity change. The MOSFETs are shut off when the counter reaches 3 and remain shut off until the shutdown condition is cleared by disabling and re-enabling the driver. The shutdown condition becomes reset by de-asserting the ENN input or clearing the TOFF parameter.
3	SHORTA					
2	OTPW				Overtemp. warning	0: No overtemperature warning condition. 1: Warning threshold is active.
1	OT				Overtemp. shutdown	0: No overtemperature shutdown condition. 1: Overtemperature shutdown has occurred.
0	SG				StallGuard2 status	0: No motor stall detected. 1: StallGuard2 threshold has been reached, and the SG_TST output is driven high.

7.11 Device Initialization

The following sequence of SPI commands is an example of enabling the driver and initializing the chopper:

```
SPI = $901B4;    // Hysteresis mode
or
SPI = $94557;    // Constant toff mode
SPI = $D001F;    // Current setting: $d001F (max. current)
SPI = $E0010;    // low driver strength, StallGuard2 read, SDOFF=0
SPI = $00000;    // 256 microstep setting
```

First test of CoolStep current control:

```
SPI = $A8202;    // Enable CoolStep with minimum current ¼ CS
```

The configuration parameters should be tuned to the motor and application for optimum performance.

8 STEP/DIR Interface

The STEP and DIR inputs provide a simple, standard interface compatible with many existing motion controllers. The MicroPlyer STEP pulse interpolator brings the smooth motor operation of high-resolution microstepping to applications originally designed for coarser stepping and reduces pulse bandwidth.

8.1 Timing

Figure 8.1 shows the timing parameters for the STEP and DIR signals, and the table below gives their specifications. When the DEDGE mode bit in the DRVCTRL register is set, both edges of STEP are active. If DEDGE is cleared, only rising edges are active. STEP and DIR are sampled and synchronized to the system clock. An internal analog filter removes glitches on the signals, such as those caused by long PCB traces. If the signal source is far from the chip, and especially if the signals are carried on cables, the signals should be filtered or differentially transmitted.

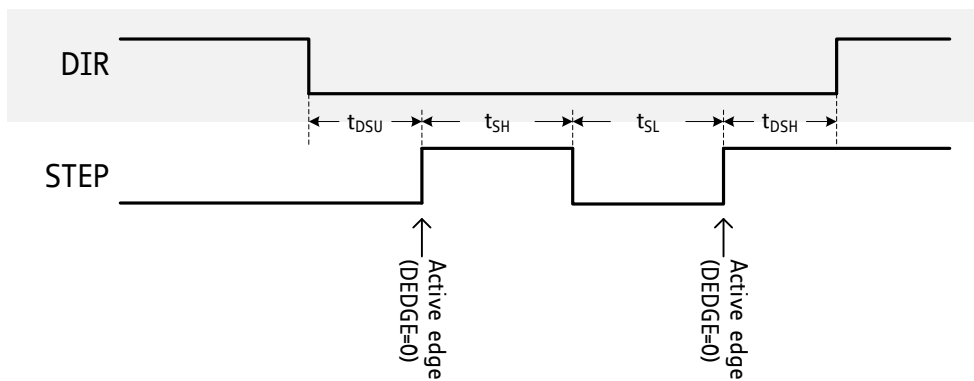

Figure 8.1 STEP and DIR timing.

STEP and DIR Interface Timing		AC-Characteristics				
		clock period is t_{CLK}				
Parameter	Symbol	Conditions	Min	Typ	Max	Unit
Step frequency (at maximum microstep resolution)	f_{STEP}	DEEDGE=0			$\frac{1}{2} f_{CLK}$	
		DEEDGE=1			$\frac{1}{4} f_{CLK}$	
Fullstep frequency	f_{FS}				$f_{CLK}/512$	
STEP input low time	t_{SL}		$\max(t_{FILTS}, t_{CLK}+20)$			ns
STEP input high time	t_{SH}		$\max(t_{FILTS}, t_{CLK}+20)$			ns
DIR to STEP setup time	t_{DSU}		20			ns
DIR after STEP hold time	t_{DSH}		20			ns
STEP and DIR spike filtering time TMC2660C *)	t_{FILTS}	Rising and falling edge	12	20	40	ns
STEP and DIR sampling relative to rising CLK input	$t_{SDCLKHI}$	Before rising edge of CLK		t_{FILTS}		ns

*) The -C type has reduced filter time in order to reduce the danger of skipped step pulses

8.2 Microstep Table

The internal microstep table maps the sine function from 0° to 90°, and symmetries allow mapping the sine and cosine functions from 0° to 360° with this table. The angle is encoded as a 10-bit unsigned integer MSTEP provided by the microstep counter. The size of the increment applied to the counter while microstepping through this table is controlled by the microstep resolution setting MRES in the DRVCTRL register. Depending on the DIR input, the microstep counter is increased (DIR=0) or decreased (DIR=1) by the step size with each STEP active edge. Despite many entries in the last quarter of the table being equal, the electrical angle continuously changes, because either the sine wave or cosine wave is in an area, where the current vector changes monotonically from position to position. Figure 8.2 shows the table. The largest values are 248, which leaves headroom used for adding an offset.

Entry	0-31	32-63	64-95	96-127	128-159	160-191	192-223	224-255
0	1	49	96	138	176	207	229	243
1	2	51	97	140	177	207	230	244
2	4	52	98	141	178	208	231	244
3	5	54	100	142	179	209	231	244
4	7	55	101	143	180	210	232	244
5	8	57	103	145	181	211	232	245
6	10	58	104	146	182	212	233	245
7	11	60	105	147	183	212	233	245
8	13	61	107	148	184	213	234	245
9	14	62	108	150	185	214	234	246
10	16	64	109	151	186	215	235	246
11	17	65	111	152	187	215	235	246
12	19	67	112	153	188	216	236	246
13	21	68	114	154	189	217	236	246
14	22	70	115	156	190	218	237	247
15	24	71	116	157	191	218	237	247
16	25	73	118	158	192	219	238	247
17	27	74	119	159	193	220	238	247
18	28	76	120	160	194	220	238	247
19	30	77	122	161	195	221	239	247
20	31	79	123	163	196	222	239	247
21	33	80	124	164	197	223	240	247
22	34	81	126	165	198	223	240	248
23	36	83	127	166	199	224	240	248
24	37	84	128	167	200	225	241	248
25	39	86	129	168	201	225	241	248
26	40	87	131	169	201	226	241	248
27	42	89	132	170	202	226	242	248
28	43	90	133	172	203	227	242	248
29	45	91	135	173	204	228	242	248
30	46	93	136	174	205	228	243	248
31	48	94	137	175	206	229	243	248

Figure 8.2 Internal microstep table showing the first quarter of the sine wave.

8.3 Changing Resolution

The application may need to change the microstepping resolution to get the best performance from the motor. For example, high-resolution microstepping may be used for precision operations on a workpiece, and then fullstepping may be used for maximum torque at maximum velocity to advance to the next workpiece. When changing to coarse resolutions like fullstepping or halfstepping, switching should occur at or near positions that correspond to steps in the lower resolution, as shown in Table 8.1.

Step Position	MSTEP Value	Coil A Current	Coil B Current
Half step 0	0	0%	100%
Full step 0	128	70.7%	70.7%
Half step 1	256	100%	0%
Full step 1	384	70.7%	-70.7%
Half step 2	512	0%	-100%
Full step 2	640	-70.7%	-70.7%
Half step 3	768	-100%	0%
Full step 3	896	-70.7%	70.7%

Table 8.1 Optimum positions for changing to halfstep and fullstep resolution

8.4 MicroPlyer Step Interpolator

For each active edge on STEP, MicroPlyer produces 16 microsteps at 256x resolution, as shown in Figure 8.3. MicroPlyer is enabled by setting the INTPOL bit in the DRVCTRL register. It supports input at 16x resolution, which it transforms into 256x resolution. The step rate for each 16 microsteps is determined by measuring the time interval of the previous step period and dividing it into 16 equal parts. The maximum time between two microsteps corresponds to 2^{20} (roughly one million system clock cycles), for an even distribution of 1/256 microsteps. At 16MHz system clock frequency, this results in a minimum step input frequency of 16Hz for MicroPlyer operation (one fullstep per second). A lower step rate causes the STST bit to be set, which indicates a standstill event. At that frequency, microsteps occur at a rate of $\frac{\text{system clock frequency}}{2^{16}} \approx 250\text{Hz} = 244$.

Attention

MicroPlyer only works well with a stable STEP frequency. Do not use the DEDGE option if the STEP signal does not have a 50% duty cycle.

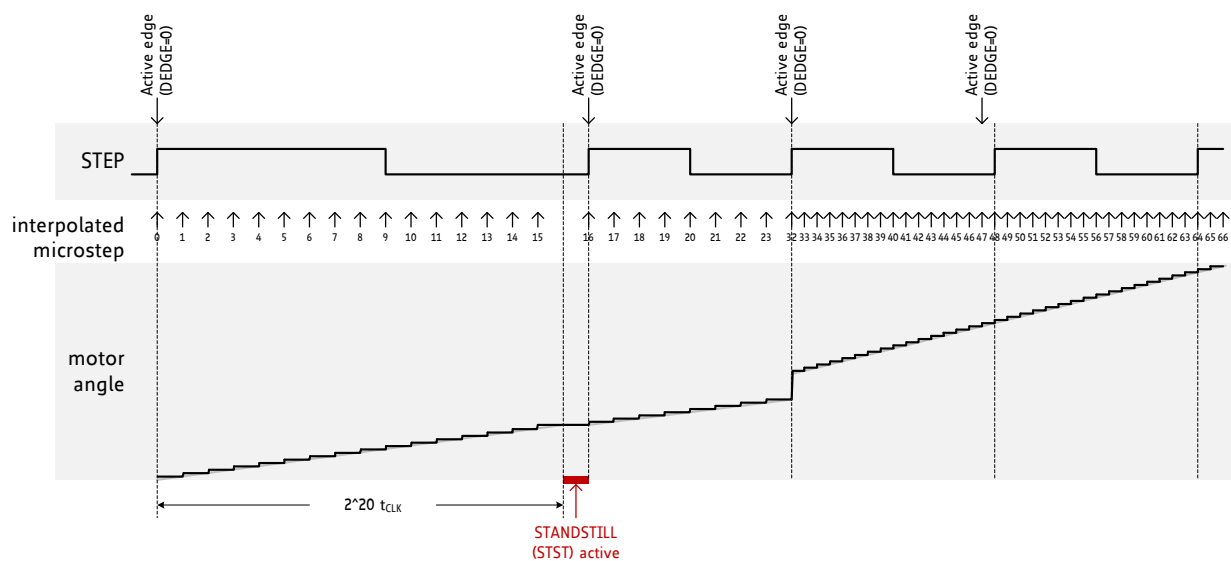

Figure 8.3 MicroPlyer microstep interpolation with rising STEP frequency.

In Figure 8.3, the first STEP cycle is long enough to set the STST bit. This bit is cleared on the next STEP active edge. Then, the STEP frequency increases and after one cycle at the higher rate MicroPlyer increases the interpolated microstep rate. During the last cycle at the slower rate, MicroPlyer did not generate all 16 microsteps, so there is a small jump in motor angle between the first and second cycles at the higher rate.

8.5 Standstill current reduction

When a standstill event is detected, the motor current should be reduced to save energy and reduce heat dissipation in the power MOSFET stage. This is especially true at halfstep positions, which are a worst-case condition for the driver and motor because the full energy is consumed in one bridge and one motor coil.

Attention:

Stand still current reduction is required when operating near the thermal limits of the application. Refer the current and temperature limitations in chapter 18 as a guideline.

Hint

Implement a current reduction to 10% to 75% of the required run current for motor standstill. This saves more than 50% to more than 90% of energy. The actual level depends on the required holding force and on the required microstep precision during standstill. In standalone mode, a reduction to 50% current is possible using a configuration input.

9 Current Setting

The internal 5V supply voltage available at the pin 5VOUT is used as a reference for the coil current regulation based on the sense resistor voltage measurement. The desired maximum motor current is set by selecting an appropriate value for the sense resistor. The sense resistor voltage range can be selected by the VSENSE bit in the DRVCONF register. The low sensitivity (high sense resistor voltage, VSENSE=0) brings best and most robust current regulation, while high sensitivity (low sense resistor voltage; VSENSE=1) reduces power dissipation in the sense resistor. This setting reduces the power dissipation in the sense resistor by nearly half.

After choosing the VSENSE setting and selecting the sense resistor, the currents to both coils are scaled by the 5-bit current scale parameter CS in the SGSCONF register. The sense resistor value is chosen so that the maximum desired current (or slightly more) flows at the maximum current setting (CS = %11111).

Using the internal sine wave table, which has amplitude of 248, the RMS motor current can be calculated by:

$$I_{RMS} = \frac{CS + 1}{32} * \frac{V_{FS}}{R_{SENSE}} * \frac{1}{\sqrt{2}}$$

The momentary motor current is calculated as:

$$I_{MOT} = \frac{CURRENT_{A/B}}{248} * \frac{CS + 1}{32} * \frac{V_{FS}}{R_{SENSE}}$$

where:

CS is the effective current scale setting as set by the CS bits and modified by CoolStep. The effective value ranges from 0 to 31.

V_{FS} is the sense resistor voltage at full scale, as selected by the VSENSE control bit (refer to the electrical characteristics).

CURRENT_{A/B} is the value set by the current setting in SPI mode or the internal sine table in STEP/DIR mode.

Parameter	Description	Setting	Comment
CS	<i>Current scale.</i> Scales both coil current values as taken from the internal sine wave table or from the SPI interface. For high precision motor operation, work with a current scaling factor in the range 16 to 31, because scaling down the current values reduces the effective microstep resolution by making microsteps coarser. This setting also controls the maximum current value set by CoolStep.	0 ... 31	Scaling factor: 1/32, 2/32, ... 32/32
VSENSE	Allows control of the sense resistor <i>voltage range</i> or adaptation of one electronic module to different maximum motor currents.	0	325mV
		1	173mV

Pay special attention concerning the thermal design and current limits imposed by it!
Be sure to reduce the current to a value at or below the maximum standstill current limits as specified in chapter 18. This is important due to thermal restrictions for continuous current in a single bridge. The worst case is standstill in a half step position where one bridge has 0 current and the other bridge has *RMS value * √2 current*.

9.1 Sense Resistors

Sense resistors should be carefully selected. The full motor current flows through the sense resistors. As they also see the switching spikes from the MOSFET bridges, a low-inductance type such as film or composition resistors is required to prevent spikes causing ringing. A low-inductance, low-resistance PCB layout is essential. Keep the high-current interconnections as short as possible as shown in Figure 9.1. A massive ground plane is best. Because the sense resistor inputs are susceptible to damage from negative overvoltages, an additional input protection resistor helps protect against a motor cable break or ringing on long motor cables.

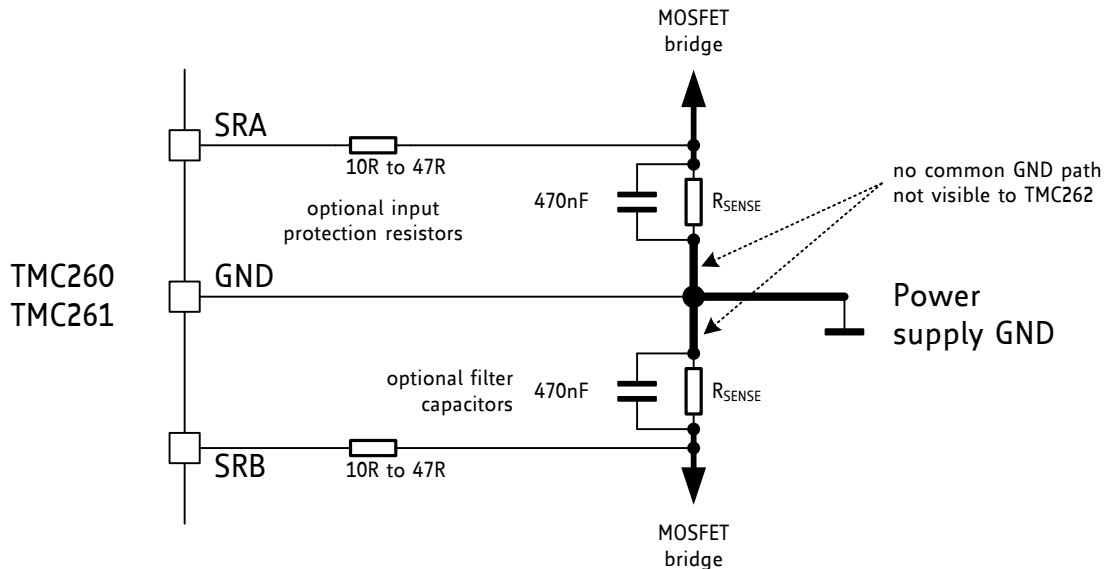

Figure 9.1 Sense resistor grounding and protection components

The sense resistor needs to be able to conduct the peak motor coil current, especially in motor standstill conditions, unless standby power is reduced. Under normal conditions, the sense resistor sees the motor coil current with a duty cycle well below 50%.

The peak sense resistor power dissipation is:

$$P_{RSMAX} = \frac{\left(V_{SENSE} * \frac{CS + 1}{32} \right)^2}{R_{SENSE}}$$

For high-current applications, power dissipation is halved by using the lower sense resistor voltage setting and the corresponding lower resistance value. In this case, any voltage drop in the PCB traces has a larger influence on the result. A compact power stage layout with massive ground plane is best to avoid parasitic resistance effects.

CHOICE OF R_{SENSE} AND RESULTING MAX. MOTOR CURRENT FOR $CS=31$		
R_{SENSE} [Ω]	RMS current [A] $V_{SENSE}=0$	RMS current [A] $V_{SENSE}=1$
0.33	0.7	0.35
0.27	0.8	0.43
0.22	1.0	0.53
0.15	1.5	0.8
0.12	1.8 (above max. current)	1.0
0.10	2.2 (above max. current)	1.2

10 Chopper Operation

The currents through both motor coils are controlled using choppers. The choppers work independently of each other. Figure 10.1 shows the three chopper phases:

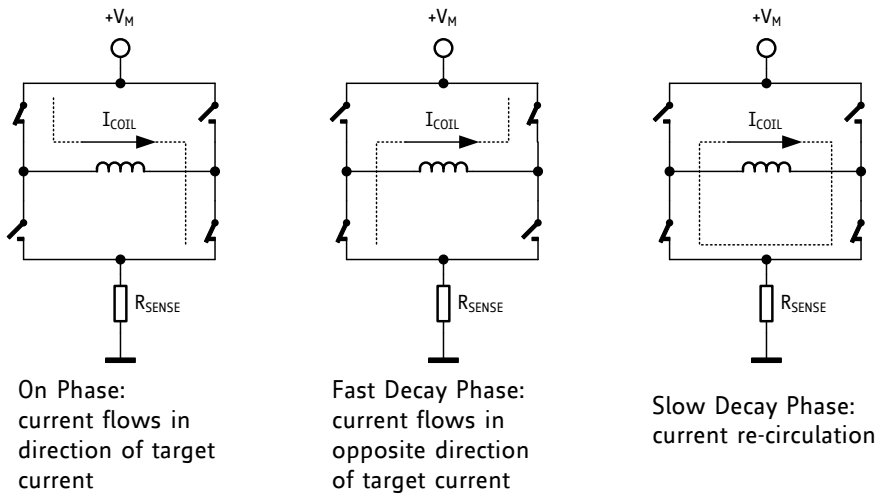

Figure 10.1 Chopper phases.

Although the current could be regulated using only on phases and fast decay phases, insertion of the slow decay phase is important to reduce electrical losses and current ripple in the motor. The duration of the slow decay phase is specified in a control parameter and sets an upper limit on the chopper frequency. The current comparator can measure coil current during phases when the current flows through the sense resistor, but not during the slow decay phase, so the slow decay phase is terminated by a timer. The on phase is terminated by the comparator when the current through the coil reaches the target current. The fast decay phase may be terminated by either the comparator or another timer.

When the coil current is switched, spikes at the sense resistors occur due to charging and discharging parasitic capacitances. During this time, typically one or two microseconds, the current cannot be measured. Blanking is the time when the input to the comparator is masked to block these spikes.

There are two chopper modes available: a new high-performance chopper algorithm called spreadCycle and a proven constant off-time chopper mode. The constant off-time mode cycles through three phases: on, fast decay, and slow decay. The spreadCycle mode cycles through four phases: on, slow decay, fast decay, and a second slow decay.

These parameters are used for controlling both chopper modes:

Parameter	Description	Setting	Comment
TOFF	Off time. This setting controls the duration of the slow decay time and limits the maximum chopper frequency. For most applications an off time within the range of 5 μ s to 20 μ s will fit. If the value is 0, the MOSFETs are all shut off and the motor can freewheel. If the value is 1 to 15, the number of system clock cycles in the slow decay phase is: $N_{CLK} = (TOFF \cdot 32) + 24$ The SD-Time is $t = \frac{1}{f_{CLK}} \cdot N_{CLK}$	0 1... 15	Chopper off. Off time setting. A setting in the range of 2-5 is recommended for SpreadCycle, higher values for classic chopper.

Parameter	Description	Setting	Comment
TBL	Blanking time. This time needs to cover the switching event and the duration of the ringing on the sense resistor. For most low-current applications, a setting of 16 or 24 is good. For high-current applications, a setting of 36 or 54 may be required.	0	16 system clock cycles
		1	24 system clock cycles
		2	36 system clock cycles
		3	54 system clock cycles
CHM	Chopper mode bit. SpreadCycle is recommended for most applications.	0	SpreadCycle mode
		1	Constant off time mode
EN_PFD	Enable passive fast decay. Setting this bit, adds a passive fast decay phase of 512 clock cycles for each bridge following zero crossing of the motor current. The passive fast decay will dampen the energy of motor resonances at medium velocity.	1	Resonance dampening on.

10.1 spreadCycle Chopper

The SpreadCycle (patented) chopper algorithm is a precise and simple to use chopper mode which automatically determines the optimum length for the fast-decay phase. The SpreadCycle will provide superior microstepping quality even with default settings. Several parameters are available to optimize the chopper to the application.

Each chopper cycle is comprised of an on phase, a slow decay phase, a fast decay phase and a second slow decay phase (see Figure 10.3). The two slow decay phases and the two blank times per chopper cycle put an upper limit to the chopper frequency. The slow decay phases typically make up for about 30%-70% of the chopper cycle in standstill and are important for low motor and driver power dissipation.

Calculation of a starting value for the slow decay time *TOFF*:

EXAMPLE:

Target Chopper frequency: 25kHz.

Assumption: Two slow decay cycles make up for 50% of overall chopper cycle time

$$t_{OFF} = \frac{1}{25kHz} * \frac{50}{100} * \frac{1}{2} = 10\mu s$$

For the *TOFF* setting this means:

$$TOFF = (t_{OFF} * f_{CLK} - 24)/32$$

With 12 MHz clock this gives a setting of *TOFF*=3.0, i.e. 3.

With 16 MHz clock this gives a setting of *TOFF*=4.25, i.e. 4 or 5.

The hysteresis start setting forces the driver to introduce a minimum amount of current ripple into the motor coils. The current ripple must be higher than the current ripple which is caused by resistive losses in the motor in order to give best microstepping results. This will allow the chopper to precisely regulate the current both for rising and for falling target current. The time required to introduce the current ripple into the motor coil also reduces the chopper frequency. Therefore, a higher hysteresis setting will lead to a lower chopper frequency. The motor inductance limits the ability of the chopper to follow a changing motor current. Further the duration of the on phase and the fast decay must be longer than the blanking time because the current comparator is disabled during blanking.

It is easiest to find the best setting by starting from a low hysteresis setting (e.g. *HSTRT*=0, *HEND*=0) and increasing *HSTRT*, until the motor runs smoothly at low velocity settings. This can best be checked when measuring the motor current either with a current probe or by probing the sense

resistor voltages (see Figure 10.2). Checking the sine wave shape near zero transition will show a small ledge between both half waves in case the hysteresis setting is too small. At medium velocities (i.e. 100 to 400 fullsteps per second), a too low hysteresis setting will lead to increased humming and vibration of the motor.

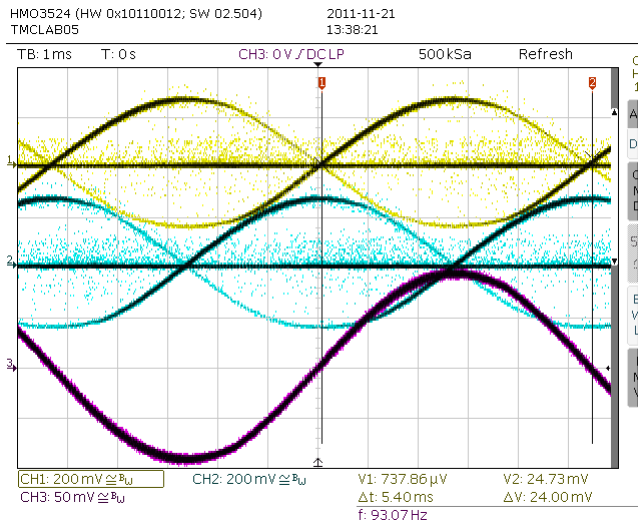

Figure 10.2 No ledges in current wave with sufficient hysteresis (magenta: current A, yellow & blue: sense resistor voltages A and B)

A too high hysteresis setting will lead to reduced chopper frequency and increased chopper noise but will not yield any benefit for the wave shape.

Quick Start

For detail tuning procedure see Application Note AN001 - *Parameterization of SpreadCycle*

As experiments show, the setting is quite independent of the motor, because higher current motors typically also have a lower coil resistance. Choosing a medium default value for the hysteresis (for example, effective HSTRT+HEND=10) normally fits most applications. The setting can be optimized by experimenting with the motor: A too low setting will result in reduced microstep accuracy, while a too high setting will lead to more chopper noise and motor power dissipation. When measuring the sense resistor voltage in motor standstill at a medium coil current with an oscilloscope, a too low setting shows a fast decay phase not longer than the blanking time. When the fast decay time becomes slightly longer than the blanking time, the setting is optimum. You can reduce the off-time setting, if this is hard to reach.

The hysteresis principle could in some cases lead to the chopper frequency becoming too low, for example when the coil resistance is high compared to the supply voltage. This is avoided by splitting the hysteresis setting into a start setting (HSTRT+HEND) and an end setting (HEND). An automatic hysteresis decremter (HDEC) interpolates between these settings, by decrementing the hysteresis value stepwise each 16, 32, 48, or 64 system clock cycles. At the beginning of each chopper cycle, the hysteresis begins with a value which is the sum of the start and the end values (HSTRT+HEND), and decrements during the cycle, until either the chopper cycle ends, or the hysteresis end value (HEND) is reached. This way, the chopper frequency is stabilized at high amplitudes and low supply voltage situations, if the frequency gets too low. This avoids the frequency reaching the audible range.

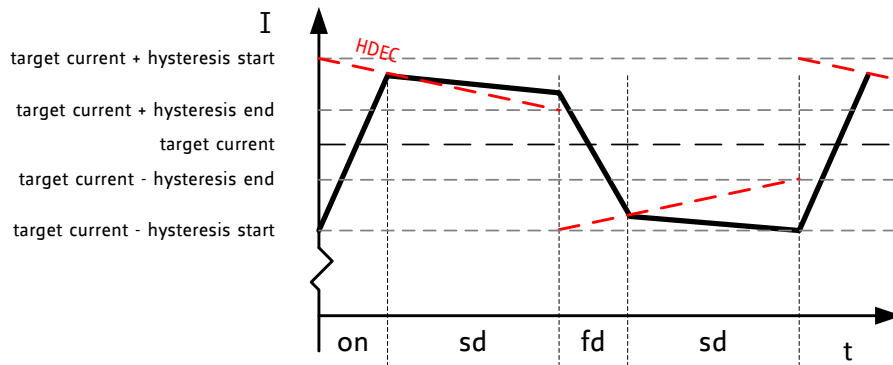

Figure 10.3 spreadCycle chopper mode showing the coil current during a chopper cycle

Three parameters control spreadCycle mode:

Parameter	Description	Setting	Comment
HSTRT	<i>Hysteresis start</i> setting. Please remark, that this value is an offset to the hysteresis end value HEND.	0.. 7	This setting adds to HEND. %000: 1 %100: 5 %001: 2 %101: 6 %010: 3 %110: 7 %011: 4 %111: 8
HEND	<i>Hysteresis end</i> setting. Sets the hysteresis end value after a number of decrements. Decrement interval time is controlled by HDEC. The sum HSTRT+HEND must be <16. At a current setting CS of max. 30 (amplitude reduced to 240), the sum is not limited.	0.. 2	Negative HEND: -3... -1 %0000: -3 %0001: -2 %0010: -1
		3	Zero HEND: 0 %0011: 0
		4.. 15	Positive HEND: 1... 12 %0100: 1 %1010: 7 %0101: 2 %1011: 8 %0110: 3 %1100: 9 %0111: 4 %1101: 10 %1000: 5 %1110: 11 %1001: 6 %1111: 12
HDEC	<i>Hysteresis decrement</i> setting. This setting determines the slope of the hysteresis during on time and during fast decay time. It sets the number of system clocks for each decrement.	0.. 3	0: fast decrement 3: very slow decrement %00: 16 %01: 32 %10: 48 %11: 64

EXAMPLE:

A hysteresis of 4 has been chosen. You might decide to not use hysteresis decrement. In this case set:

HEND=6 (sets an effective end value of 6-3=3)
HSTRT=0 (sets minimum hysteresis, i.e. 1: 3+1=4)

In order to take advantage of the variable hysteresis, we can set most of the value to the HSTRT, i.e. 4, and the remaining 1 to hysteresis end. The resulting configuration register values are as follows:

HEND=0 (sets an effective end value of -3)
HSTRT=6 (sets an effective start value of hysteresis end +7: 7-3=4)

Hint

Highest motor velocities benefit from setting TOFF to 2 or 3 and a short TBL of 2 or 1.

10.2 Constant Off-Time Mode

The classic constant off-time chopper uses a fixed-time fast decay following each on phase. While the duration of the on phase is determined by the chopper comparator, the fast decay time needs to be fast enough for the driver to follow the falling slope of the sine wave, but it should not be so long that it causes excess motor current ripple and power dissipation. This can be tuned using an oscilloscope or evaluating motor smoothness at different velocities. A good starting value is a fast decay time setting similar to the slow decay time setting.

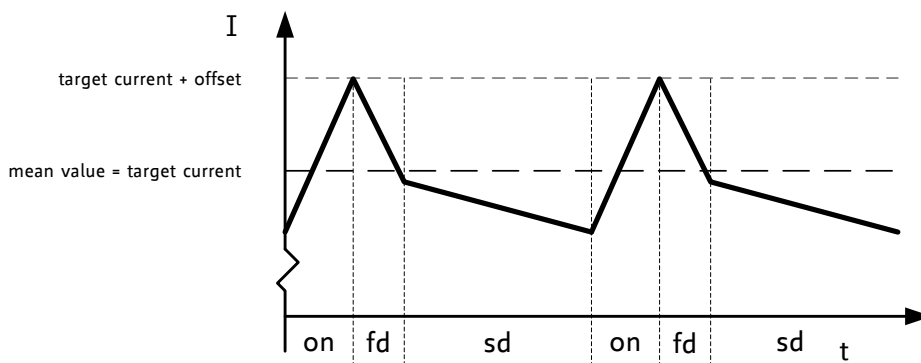

Figure 10.4 Constant off-time chopper with offset showing the coil current during two cycles

After tuning the fast decay time, the offset should be tuned for a smooth zero crossing. This is necessary because the fast decay phase makes the absolute value of the motor current lower than the target current (see Figure 10.5). If the zero offset is too low, the motor stands still for a short moment during current zero crossing. If it is set too high, it makes a larger microstep. Typically, a positive offset setting is required for smoothest operation.

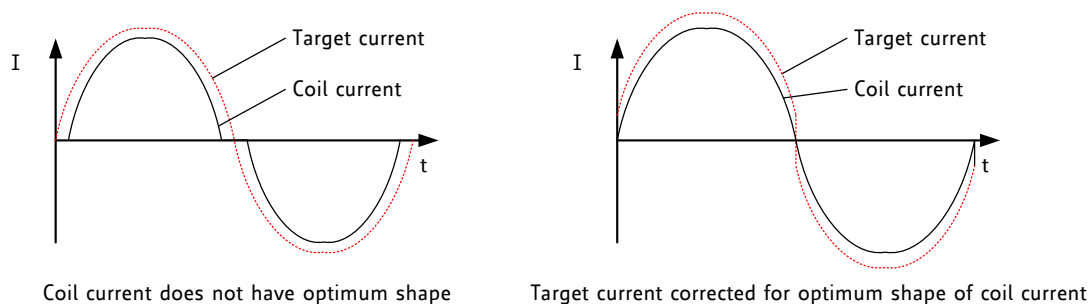

Figure 10.5 Zero crossing with correction using sine wave offset.

Three parameters control constant off-time mode:

Parameter	Description	Setting	Comment
TFD (HSTART & HDEC0)	<i>Fast decay time</i> setting. With CHM=1, these bits control the portion of fast decay for each chopper cycle.	0	Slow decay only.
		1... 15	Duration of fast decay phase.
OFFSET (HEND)	<i>Sine wave offset</i> . With CHM=1, these bits control the sine wave offset. A positive offset corrects for zero crossing error.	0...2	Negative offset: -3... -1
		3	No offset: 0
		4... 15	Positive offset: 1... 12
NCCFD (HDEC1)	Selects usage of the <i>current comparator</i> for termination of the <i>fast decay</i> cycle. If current comparator is enabled, it terminates the fast decay cycle in case the current reaches a higher negative value than the actual positive value.	0	Enable comparator termination of fast decay cycle.
		1	End by time only.

10.2.1 Random Off Time

In the constant off-time chopper mode, both coil choppers run freely without synchronization. The frequency of each chopper mainly depends on the coil current and the motor coil inductance. The inductance varies with the microstep position. With some motors, a slightly audible beat can occur between the chopper frequencies when they are close together. This typically occurs at a few microstep positions within each quarter wave. This effect is usually not audible when compared to mechanical noise generated by ball bearings, etc. Another factor which can cause a similar effect is a poor layout of the sense resistor GND connections.

Hint

A common cause of motor noise is a bad PCB layout causing coupling of both sense resistor voltages. Noise caused by an insufficient PCB layout cannot be overcome by chopper settings.

To minimize the effect of a beat between both chopper frequencies, an internal random generator is provided. It modulates the slow decay time setting when switched on by the RNDTF bit. The RNDTF feature further spreads the chopper spectrum, reducing electromagnetic emission on single frequencies.

Parameter	Description	Setting	Comment
RNDTF	Enables a random off-time generator, which slightly modulates the off-time t_{OFF} using a random polynomial.	0	Disable.
		1	Random modulation enable.

11 Power MOSFET Stage

The gate current for the power MOSFETs can be adapted to influence the slew rate at the coil outputs. The main features of the stage are:

- 5V gate drive voltage for low-side N-MOS transistors, 10V for high-side P-MOS transistors.
- The gate drivers protect the bridges actively against cross-conduction using an internal Q_{GD} protection that holds the MOSFETs safely off.
- Automatic break-before-make logic minimizes dead time and diode-conduction time.
- Integrated overcurrent protection detects a short of the motor wires and protects the MOSFETs.

The low-side gate driver is supplied by the 5VOUT pin. The low-side driver supplies 0V to the MOSFET gate to close the MOSFET, and 5VOUT to open it. The high-side gate driver voltage is supplied by the VS and the VHS pin. VHS is more negative than VS and allows opening the VS referenced high-side MOSFET. The high-side driver supplies VS to the P channel MOSFET gate to close the MOSFET and VHS to open it. The effective low-side gate voltage is roughly 5V; the effective high-side gate voltage is roughly 8V.

Parameter	Description	Setting	Comment
SLPL	Low-side slope control. Controls the MOSFET gate driver current. Set to 0, 1 or 2. Slopes are fast to minimize package power dissipation.	0.. 3	%00: Minimum. %01: Minimum. %10: Medium. %11: Maximum.
SLPH	High-side slope control. Controls the MOSFET gate driver current. For the TMC260 set identical to SLPL to match LS slope. For the TMC261 set to 0 or 1 for medium slope. Set to 2 to match low-side slope with SLPL=0 or 1. Set to 3 with SLPL=2.	0.. 3	%00: Minimum. %01: Minimum+TC. %10: Medium+TC. %11: Maximum.

11.1 Break-Before-Make Logic

Each half-bridge must be protected against cross-conduction during switching events. When switching off the low-side MOSFET, its gate first needs to be discharged before the high-side MOSFET is allowed to switch on. The same goes when switching off the high-side MOSFET and switching on the low-side MOSFET. The time for charging and discharging of the MOSFET gates depends on the MOSFET gate charge and the gate driver current set by SLPL and SLPH. The BBM (break-before-make) logic measures the gate voltage and automatically delays turning on the opposite bridge transistor until its counterpart is discharged. This way, the bridge will always switch with optimized timing independent of the slope setting.

11.2 ENN Input

The MOSFETs can be completely disabled in hardware by pulling the ENN input high. This allows the motor to free-wheel. An equivalent function can be performed in software by setting the parameter TOFF to zero. The hardware disable is available for allowing the motor to be hot plugged. For the TMC260, it can be used in overvoltage situations. The TMC260 can withstand voltages of up to 60V when the MOSFETs are disabled. If a hardware disable function is not needed, tie ENN low.

12 Diagnostics and Protection

12.1 Short Protection

The TMC260C / TMC261C protects the MOSFET power stages against a short circuit or overload condition by monitoring the voltage drop in the high-side MOSFETs, as well as the voltage drop in sense resistor and low-side MOSFETs (Figure 12.1). A programmable short detection delay (*shortdelay*) allows adjusting the detector to work with different power stages and load conditions. Additionally, the short detection is protected against single events, e.g., caused by ESD discharges, by retrying three times before switching off the motor continuously. The low side short detector also provides for overcurrent detection. It needs to be explicitly enabled by programming.

Parameter	Description	Setting	Comment
SHRTSENS	The high-side overcurrent detector can be set to a higher sensitivity by setting this flag. This will allow detection of wrong cabling even with higher resistive motors.	0/1	0: Low sensitivity 1: High sensitivity
TS2G	Short detection delay for high-side and low side detectors. The short detection delay shall cover the bridge switching time. %01 will work for most applications. A higher delay makes detection less sensitive to capacitive load.	0/1	%00: 3.2µs. %01: 1.6µs. %10: 1.2µs. %11: 0.8µs.
DIS_S2G	Allows to disable short to VS protection.	0/1	Leave detection enabled for normal use (0).
EN_S2VS	Explicitly enable short to VS and overcurrent protection by setting this bit.	0/1	Enable detection for normal use (1).

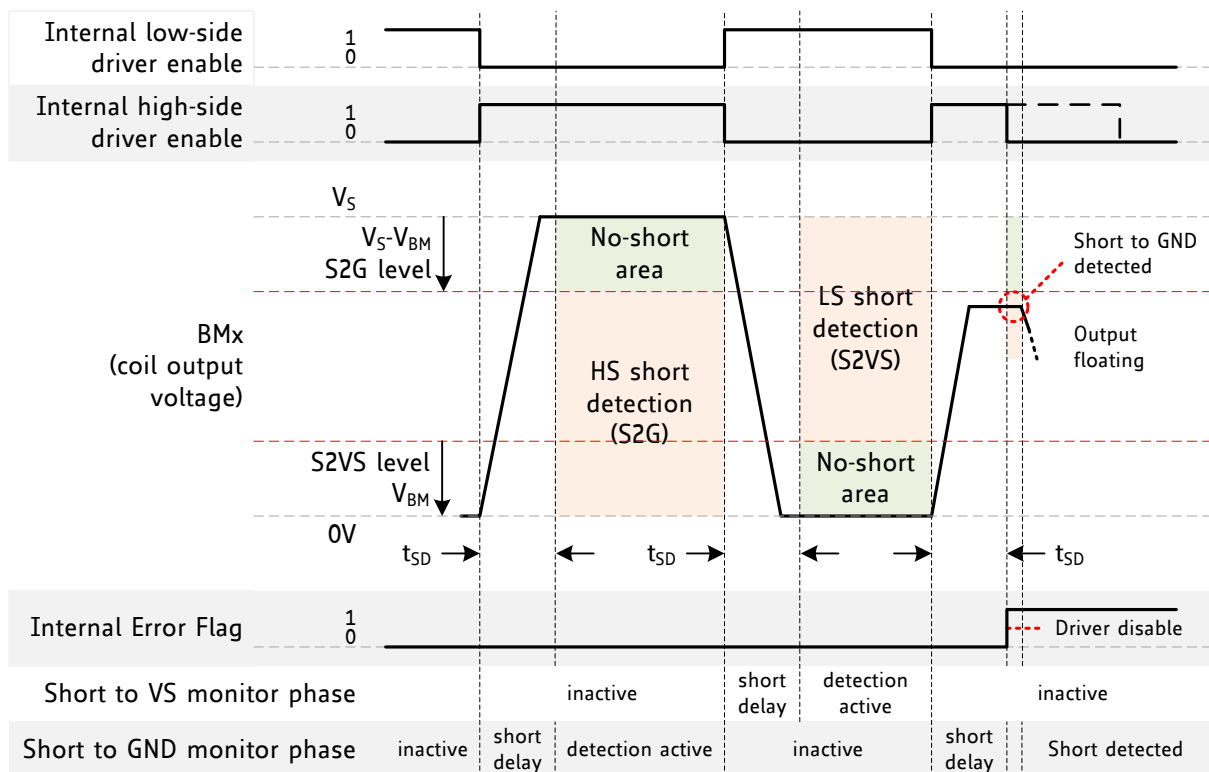

Figure 12.1 Short detection timing

As the low-side short detection includes the sense resistor, it is sensitive to the actual sense resistor and provides a good precision of overcurrent detection. This way, it will safely cover most overcurrent conditions.

Status flag	Description	Range	Comment
SHORTA	The SHORT bits identify a short condition on coil A or coil B persisting for multiple chopper cycles. The bits are cleared when the MOSFETs are disabled. Detailed warning for high-side or low-side FETs is available in S2VSA and S2VSB (low-side short detector) and S2GA and S2GB (high-side short detector)	0 / 1	0: No short detected 1: Short detected
SHORTB			
S2VSA			
S2VSB			
S2GA			
S2GB			

Hint

Once a short condition is safely detected, the corresponding driver bridge (A or B) becomes switched off, and the *s2ga* or *s2gb* flag, respectively *s2vsa* or *s2vsb* becomes set. To restart the motor, disable and re-enable the driver.

Attention

Short protection cannot protect the system and the power stages for all possible short events, as a short event is rather undefined, and a complex network of external components may be involved. Therefore, short circuits should basically be avoided.

12.2 Open-Load Detection

Interrupted cables are a common cause for systems failing, e.g. when connectors are not firmly plugged. The TMC260/TMC261 detect open load conditions by checking if it can reach the desired motor coil current. This way, also undervoltage conditions, high motor velocity settings or short and overtemperature conditions may cause triggering of the open load flag, and inform the user, that motor torque may suffer. In motor stand still, open load cannot be measured, as the coils might eventually have zero current.

Hint

Open load detection is provided for system debugging. Open load detection does not necessarily indicate a malfunction of the driver. To safely detect an interrupted coil connection, read out the open load flags at low or nominal motor velocity operation, only. However, the *ola* and *olb* flags have just informative character and do not cause any action of the driver. False indication may result with full- or halfstep operation. Use microstepping for a safe result.

The open-load detection status is indicated by two bits:

Status flag	Description	Range	Comment
OLA	These bits indicate an open-load condition on coil A and coil B. The flags become set, if no chopper event has happened during the last period with constant coil polarity. The flag is not updated with too low actual coil current below 1/16 of maximum setting. It is a pure indicator. No action is taken depending on these flags.	0 / 1	0: No open-load detected 1: Open-load detected
OLB			

12.3 Temperature Sensors

The drivers integrate a four-level temperature sensor (100°C pre-warning, 120°C overtemperature release and selectable 136°C / 150°C thermal shutdown) for diagnostics and for protection of the IC and the integrated MOSFETs as well as for adjacent components against excess heat. Choose the overtemperature level to safely cover error conditions like missing heat convection. Heat is mainly generated by the power MOSFETs, and, at increased voltage, by the internal voltage regulators. For many applications, already the overtemperature pre-warning will indicate an abnormal operation situation and can be used to initiate user warning or power reduction measures like motor current reduction. The thermal shutdown is just an emergency measure and temperature rising to the shutdown level should be prevented by design.

Hint for -C type, only

After triggering the overtemperature sensor (ot flag), the driver remains switched off until the system temperature falls below the overtemperature release level (120°C) to avoid continuous heating to the shutdown level. Cool down typically needs a few 100ms to 1 second.

The high-side P-channel gate drivers have a temperature dependency which can be compensated to some extent by increasing the gate driver current when the warning temperature threshold is reached. The chip automatically corrects for the temperature dependency above the warning temperature when the temperature-compensated modes of SLPH is used. In these modes, the gate driver current is increased by one step when the temperature warning threshold is reached.

Status	Description	Range	Comment
OTPW	Overtemperature warning. This bit indicates whether the warning threshold is reached. Software can react to this setting by reducing current.	0 / 1	1: temperature prewarning level reached
OT	Overtemperature shutdown. This bit indicates whether the shutdown threshold has been reached and the driver has been disabled.	0 / 1	1: driver shut down due to over-temperature
OTSENS (-C type only)	Program overtemperature threshold to a reduced level to give better protection for the external power stage and other components. The driver re-enables when the temperature falls below 120°C.	0 / 1	0: 150°C 1: 136°C

12.4 Undervoltage Detection

The undervoltage detector monitors both the internal logic supply voltage and the supply voltage. It prevents operation of the chip when the MOSFETs cannot be guaranteed to operate properly because the gate drive voltage is too low. It also initializes the chip at power up.

In undervoltage conditions, the logic control block becomes reset and the driver is disabled. All MOSFETs are switched off. All internal registers are reset to zero. Software should additionally monitor the supply voltage to detect an undervoltage condition. If software cannot measure the supply voltage, an undervoltage condition can be detected by reading out the SE current value. Following a reset due to undervoltage occurs, the CS parameter is cleared, which is reflected in an SE status of 0 in the read response.

Status	Description	Range	Comment
EN_PFD (-C type only)	Set this bit to allow operation with a 5V only supply. This bit additionally controls resonance dampening of the motor.	0 / 1	Undervoltage level 0: <7V 1: <4.5V

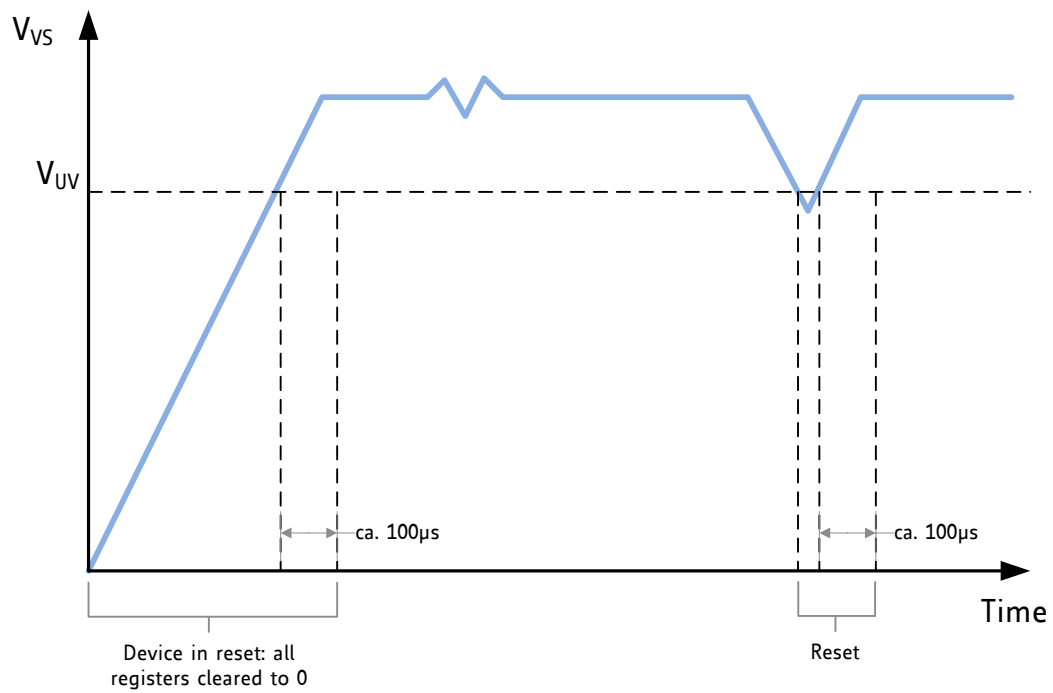

Figure 12.2 Undervoltage reset timing

Note

Be sure to operate the IC significantly above the undervoltage threshold to ensure reliable operation!
Check for SE reading back as zero to detect an undervoltage event.

13 Power Supply Sequencing

The TMC260/TMC261 generate their own 5V supply for all internal operations. The internal reset of the chip is derived from the supply voltage regulator to ensure a clean start-up of the device after power up. During start up, the SPI unit is in reset and cannot be addressed. All registers become cleared.

VCC_IO limits the voltage allowable on the inputs and outputs and is used for driving the outputs. It is included in undervoltage detection and reset (C-type, only). Therefore, the startup sequence of the VCC_IO power supply with respect to VS is not important. VCC_IO may start up before or after VS.

14 System Clock

The system clock is the timing reference for all functions. The internal system clock frequency for all operations is nominally 15MHz. An external clock of 8MHz to 20MHz can be supplied for more exact timing, especially when using CoolStep and StallGuard2.

USING THE INTERNAL CLOCK

To use the on-chip oscillator of the TMC260 / TMC261, tie CLK to GND near the chip. The actual on-chip oscillator clock frequency can be determined by measuring the delay time between the last step and assertion of the STST (standstill) status bit, which is 2^{20} clocks. There is some delay in reading the STST bit through the SPI interface, but it is easily possible to measure the oscillator frequency within 1%. Chopper timing parameters can then be corrected using this measurement, because the oscillator is relatively stable over a wide range of environmental temperatures.

Hint

In case well defined precise motor chopper operation are desired, it is supposed to work with an external clock source.

USING EXTERNAL CLOCK

An external clock frequency of up to 20MHz can be supplied. It is recommended to use an external clock frequency between 10MHz and 16MHz for best performance. Pay attention to using a near 50% duty-cycle. The external clock is enabled, and the on-chip oscillator is disabled with the first logic high driven on the CLK input.

Attention:

Never leave the external clock input floating. It is not allowed to remain within the transition region (between valid low and high levels), as spurious clock signals might lead to short impulses and can corrupt internal logic state. Provide an external pull-down resistor, in case the driver pin (i.e. microcontroller output) does not provide a safe level directly after power up. If the external clock is suspended or disabled after the internal oscillator has been disabled, the chip will not operate. Be careful to switch off the power MOSFETs (by driving the ENN input high or setting the TOFF parameter to 0) before switching off the clock, because otherwise the chopper would stop and the motor current level could rise uncontrolled. If the short to GND detection is enabled, it stays active even without clock.

The -C types provide a clock failover option to switch back to internal clock, in case of the external clock failing. The function is coupled to enabling short to VS protection (EN_S2VS).

Status	Description	Range	Comment
EN_S2VS (-C type only)	Set this bit to enable protection against a failing external CLK source. If set, the IC switches back to external clock after 32 to 48 internal clock cycles. At the same time, this bit controls the higher side short detector sensitivity	0 / 1	Undervoltage level 0: Stopping clock will stop the IC. 1: CLK fail safe protection

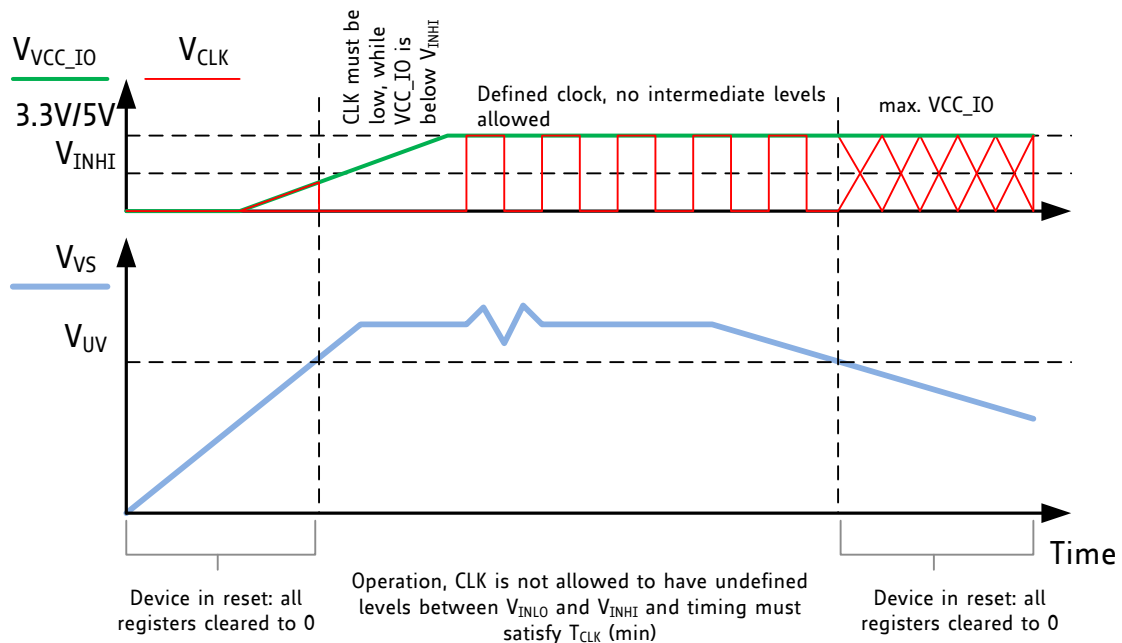

Figure 14.1 Start-up requirements of CLK input

14.1 Frequency Selection

A higher frequency allows faster step rates, faster SPI operation, and higher chopper frequencies. On the other hand, it may cause more electromagnetic emission and more power dissipation in the digital logic. Generally, a system clock frequency of 10MHz to 16MHz is best for most applications, unless the motor is to operate at the highest velocities. If the application can tolerate reduced motor velocity and increased chopper noise, a clock frequency of 4MHz to 10MHz should be considered.

CLK frequency	Comment
internal	13-16MHz, typical. Tie clock input firmly to GND. See electrical characteristics for limits. The internal clock is sufficient, unless a good reproducibility of StallGuard values is desired.
4-10 MHz	Lower range sufficient for higher inductance motors
10-16 MHz	Recommended for best results
16-20 MHz	Option in case a lower frequency is not available Ensure 40-60% duty cycle

15 Compatibility to non-C-type

The TMC260C / TMC261C are downward compatible to the non-C-types. They are designed for compatibility to existing applications, while offering several enhancements and options for new designs.

ENHANCEMENTS IN C-TYPE

- More silent chopper operation, silent motor at low motor velocity.
- VCC_IO is monitored by internal reset circuitry to ensure clean power-up and power-down.
- Overtemperature shutdown has added hysteresis. After exceeding the temperature threshold, the driver stage remains off, until temperature falls below the 120°C pre-warning threshold.
- Reduced power dissipation of internal circuitry, leading to lower heat-up.
- CMOS input levels are increased with 5V VCC_IO level to increase noise rejection.
- Reduced filtering time for STEP & DIR inputs to reduce the risk of missed step pulses.

OPTIONAL ENHANCEMENTS IN C-TYPE (ENABLE VIA CONFIGURATION BITS)

- Clock fail-safe option. In case the external clock fails, the IC defaults back to internal clock. This avoids damage to motor and driver stage. (Enable: EN_S2VS, together with short protection)
- Low-Side short detection (Short to VS) for improved robustness in case of mis-wiring or overcurrent, e.g. due to wrongly attached motor. (Enable: EN_S2VS)
- Optional higher sensitivity high-side protection for improved protection. (Enable: SHRTSENS)
- Optional lower overtemperature threshold of 136°C for more sensitive protection of the power driver. Enable: OTSENSE
- Option to work down to 5V supply voltage and to add resonance dampening. (Enable: EN_PFD)

The additional settings for C-types are highlighted in this document using green background.

The major differences to be considered when migrating an existing application from the TMC260 / TMC261 to TMC260C / TMC261C, are summarized in the following table:

Item	Change in C-type	Impact
More silent chopper in C-type	Internal noise sources have been reduced. Noise caused by internal wiring voltage drop makes up for up to 10mV for non-C-devices. This reflects in a slightly lower sense input threshold voltage.	More silent motor, especially with low velocity. C-type effective motor current about 2-3% higher.
Undervoltage monitoring of VCC_IO	IO voltage VCC_IO is monitored by the internal reset circuitry. The device becomes reset upon VCC_IO undervoltage.	Increased VCC_IO supply current (50µA), device resets upon VCC_IO undervoltage.
Hysteresis for overtemperature detector	Following overtemperature detection at 136°C or 150°C, the driver stage remains switched off until the IC cools down below 120°C.	Longer shutdown time upon overtemperature detection, safe detection by interface.
Input levels depend on VCC_IO voltage	Non-C-type input level detectors are supplied by internal 5V supply, leading to fixed 0.8V and 2.4V levels. C-types use VCC_IO supplied CMOS Schmitt-Trigger inputs instead.	Higher positive logic level for 5V VCC_IO supply. No change with 3.3V VCC_IO supply. Check levels in 5V systems.
Spike filtering time on STEP/DIR input	The filtering has been improved, while reducing the filtering time to reduce the risk of missing short step pulses.	Potential impact in systems with high noise level on STEP & DIR input pins.
CLK input filter	C-type provides better filtering against short pulses (10ns typ.).	More robust against reflections on CLK. Check timing in case of SPI rate at $\frac{1}{2} f_{CLK}$. Invert CLK signal if required.

16 Driver Protection and EME Circuitry

Some applications have to cope with ESD events caused by motor operation or external influence. Despite ESD circuitry within the driver chips, ESD events occurring during operation can cause a reset or even a destruction of the motor driver, depending on their energy. Especially plastic housings and belt drive systems tend to cause ESD events of several kV. It is best practice to avoid ESD events by attaching all conductive parts, especially the motors themselves to PCB ground, or to apply electrically conductive plastic parts. In addition, the driver can be protected up to a certain degree against ESD events or live plugging / pulling the motor, which also causes high voltages and high currents into the motor connector terminals. A simple scheme uses capacitors at the driver outputs to reduce the dV/dt caused by ESD events. Larger capacitors will bring more benefit concerning ESD suppression, but cause additional current flow in each chopper cycle, and thus increase driver power dissipation, especially at high supply voltages. The values shown are example values – they might be varied between 100pF and 1nF. The capacitors also dampen high frequency noise injected from digital parts of the application PCB circuitry and thus reduce electromagnetic emission. A more elaborate scheme uses LC filters to de-couple the driver outputs from the motor connector. Varistors in between of the coil terminals eliminate coil overvoltage caused by live plugging. Optionally protect all outputs by a varistor against ESD voltage.

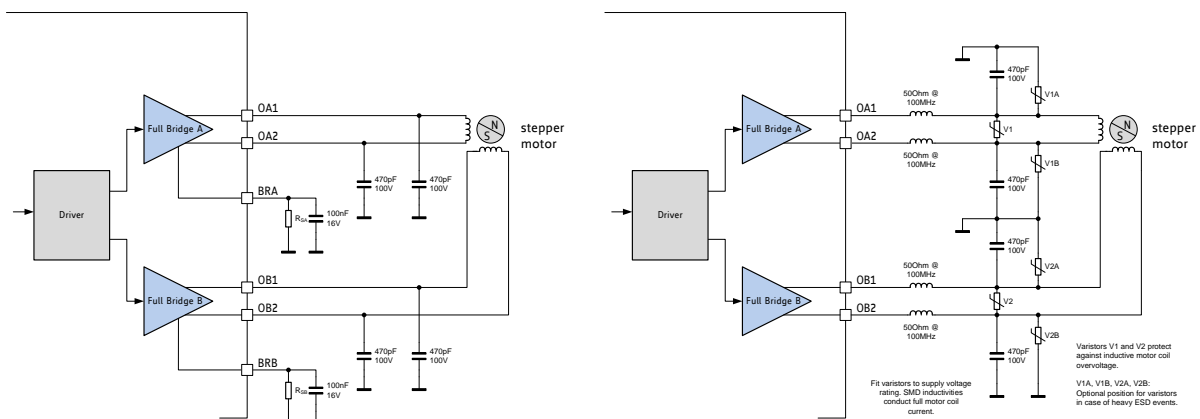

Figure 16.1 Simple ESD enhancement and more elaborate motor output protection

17 Layout Considerations

The PCB layout is critical to good performance, because the environment includes both high-sensitivity analog signals and high-current motor drive signals.

17.1 Sense Resistors

The sense resistors are susceptible to ground differences and ground ripple voltage, as the microstep current steps result in voltages down to 0.5mV. No current other than the sense resistor currents should flow through their connections to ground. Place the sense resistors close to chip with one or more vias to the ground plane for each sense resistor.

The sense resistor layout is also sensitive to coupling between the axes. The two sense resistors should not share a common ground connection trace or vias, because PCB traces have some resistance.

17.2 Power MOSFET Outputs

The OA and OB dual pin outputs on the TMC260 and TMC261 are directly connected electrically and thermally to the drain of the MOSFETs of the power stage. A symmetrical, thermally optimized layout is required to ensure proper heat dissipation of all MOSFETs into the PCB. Use thick traces and areas for vertical heat transfer into the GND plane and enough vias for the motor outputs.

The printed circuit board should have a solid ground plane spreading heat into the board and providing for a stable GND reference. All signals of the TMC260 and TMC261 are referenced to GND. Directly connect all GND pins to a common ground area.

The switching motor coil outputs have a high dV/dt , so stray capacitive coupling into high-impedance signals can occur, if the motor traces are parallel to other traces over long distances.

17.3 Power Supply Pins

Both, the VSA and VSB pins, as well as the BRA and BRB pins conduct the full motor current for a limited amount of time during each chopper cycle. Due to the resistance of bond wires connected to these pins, the pins heat up. Therefore, it is essential for current capability above 2A RMS to use a wide PCB trace for cooling and to avoid additional heat up of the pins caused by PCB trace resistance. This is simplified by also contacting the N.C. pins located next to VSA and VSB to the supply voltage. Failure to do so might affect reliability; despite heat-up of bond wires might not be visible with a thermal camera.

17.4 Power Filtering

The 470nF ceramic filtering capacitor on 5VOUT should be placed as close as possible to the 5VOUT pin, with its GND return going directly to the nearest GND pin. Use as short and as thick connections as possible. A 100nF filtering capacitor should be placed as close as possible from the VS pin to the ground plane. The motor supply pins, VSA and VSB, should be decoupled with an electrolytic (>47 μ F is recommended) capacitor and a ceramic capacitor, placed close to the device. Also place minimum 100nF capacitor for VCC_IO close to the supply pin.

17.5 Layout Example

EXAMPLE FOR UP TO 1.4A RMS

Here, an example for a layout with small board size ($\approx 20\text{cm}^2$) is shown.

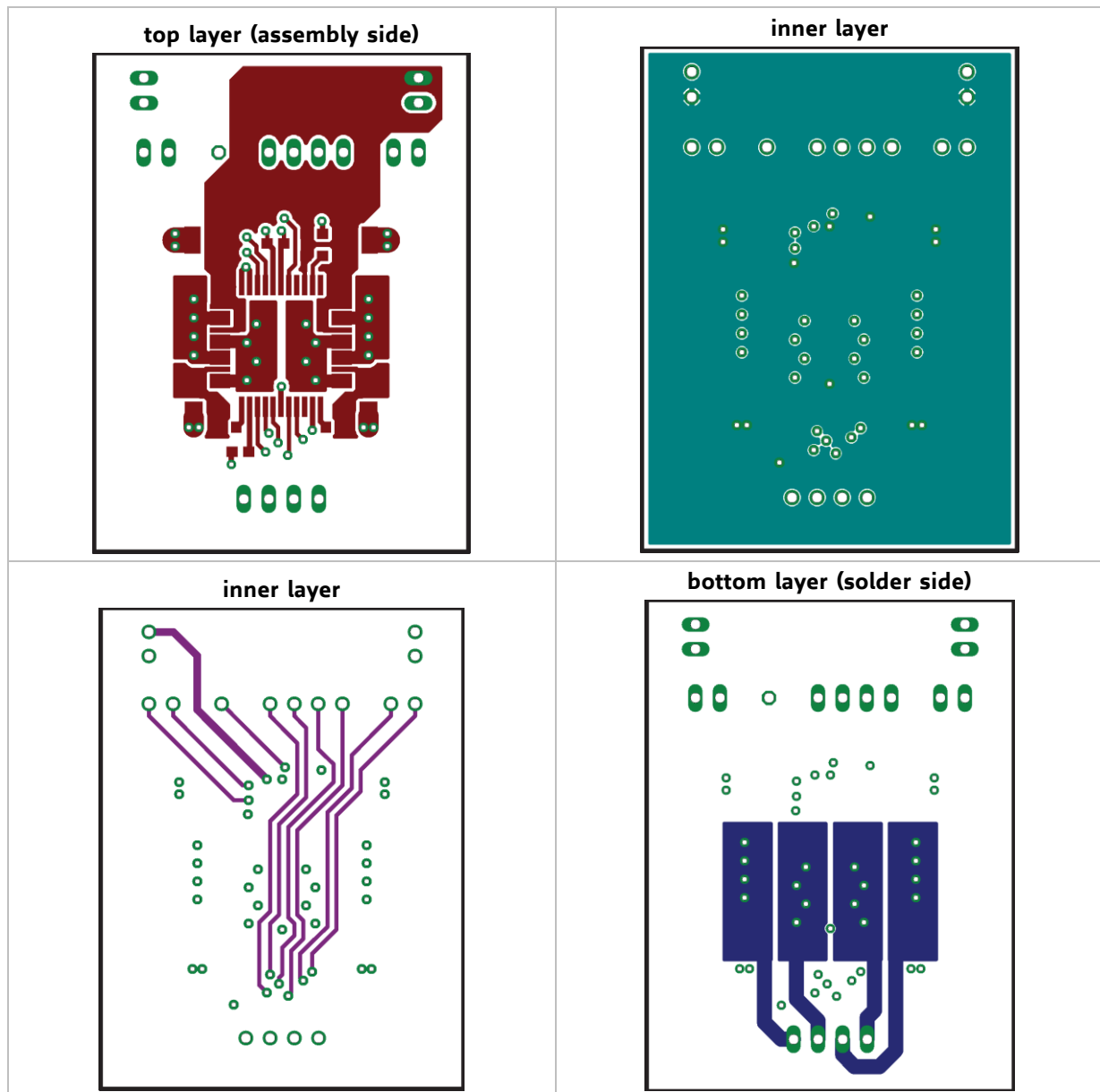
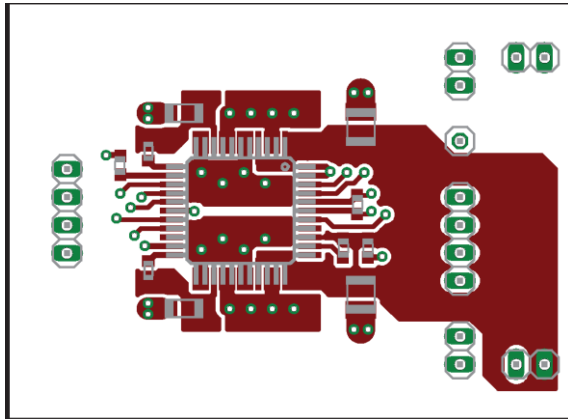

Figure 17.1 Layout example for TMC260 and TMC261

18 Absolute Maximum Ratings

The maximum ratings may not be exceeded under any circumstances. Operating the circuit at or near more than one maximum rating at a time for extended periods shall be avoided by application design.

Parameter	Symbol	Min	Max	Unit
Supply voltage (TMC261, TMC261A, TMC261C)	V_{VS}	-0.5	60	V
Supply voltage (TMC260, TMC260A, TMC260C)		-0.5	40	V
Logic supply voltage	V_{VCC}	-0.5	6.0	V
I/O supply voltage	V_{VIO}	-0.5	6.0	V
Logic input voltage	V_I	-0.5	$V_{VIO}+0.5$	V
Analog input voltage	V_{IA}	-0.5	$V_{CC}+0.5$	V
Relative high-side gate driver voltage ($V_{VM} - V_{HS}$)	V_{HSVM}	-0.5	15	V
Maximum current to/from digital pins and analog low voltage I/Os	I_{IO}		+/-10	mA
Non-destructive short time peak current into input/output pins	I_{IO}		500	mA
Bridge output peak current (10 μ s pulse)	I_{OP}		+/-7	A
Output current, continuous (one bridge active, or 0.71 x current with both bridges active)	I_{OC}	$T_A \leq 50^\circ\text{C}$	2000	mA
		$T_A \leq 85^\circ\text{C}$	1500	
		$T_A \leq 105^\circ\text{C}$	1100	
		$T_A \leq 125^\circ\text{C}$	800	
5V regulator output current	I_{5VOUT}		50	mA
5V regulator peak power dissipation ($V_{VM}-5V$) * I_{5VOUT}	P_{5VOUT}		1	W
Junction temperature	T_J	-50	150	$^\circ\text{C}$
Storage temperature	T_{STG}	-55	150	$^\circ\text{C}$
ESD-Protection (Human body model, HBM), in application	V_{ESDAP}		2	kV
ESD-Protection (Human body model, HBM), device handling	V_{ESDDH}		300	V

19 Electrical Characteristics

19.1 Operational Range

Parameter	Symbol	Min	Max	Unit
Junction temperature	T_J	-40	125	°C
Supply voltage TMC261C	V_{VS}	5	59	V
Supply voltage TMC260C	V_{VS}	5	39	V
I/O supply voltage	V_{VIO}	3.00	5.25	V

19.2 DC and AC Specifications

DC characteristics contain the spread of values guaranteed within the specified supply voltage range unless otherwise specified. Typical values represent the average value of all parts measured at +25°C. Temperature variation also causes some values to stray. A device with typical values will not leave Min/Max range within the full temperature range.

Power Supply Current	DC Characteristics					
	$V_{VS} = 24.0V$					
Parameter	Symbol	Conditions	Min	Typ	Max	Unit
Supply current, operating	I_{VS}	$f_{CLK}=16MHz, 40kHz$ chopper		8		mA
Supply current, MOSFETs off	I_{VS}	$f_{CLK}=12MHz$		5		mA
Supply current, MOSFETs off, dependency on CLK frequency	I_{VS}	f_{CLK} variable <i>additional to I_{VS0}</i>		0.1		mA/ MHz
Static supply current	I_{VS0}	$f_{CLK}=0Hz$, digital inputs at +5V or GND		3.5	5	mA
Part of supply current NOT consumed from 5V supply	I_{VSHV}	MOSFETs off		1.2		mA
IO supply current	I_{VIO}	No load on outputs, inputs at V_{IO} or GND		50	100	μA

High-Side Voltage Regulator	DC-Characteristics					
	$V_{VS} = 24.0V$					
Parameter	Symbol	Conditions	Min	Typ	Max	Unit
Output voltage ($V_{VS} - V_{HS}$)	V_{HSVS}	$I_{OUT} = 0mA$ $T_J = 25°C$	9.3	10.0	10.8	V
Lower voltage for VHS regulator to activate	V_{VS}	VS rising, first time VHS goes up from 0V		12.5	13	V
Output resistance	R_{VHS}	Static load		50		Ω

Linear Regulator	DC Characteristics					
Parameter	Symbol	Conditions	Min	Typ	Max	Unit
Output voltage	V_{SVOUT}	$I_{SVOUT} = 10mA$ $T_J = 25°C$	4.75	5.0	5.25	V
Output resistance	R_{SVOUT}	Static load			1	Ω
Deviation of output voltage over the full temperature range	$V_{SVOUT(DEV)}$	$I_{SVOUT} = 10mA$ $T_J = \text{full range}$		0	60	mV

Internal MOSFETs TMC260C		DC Characteristics				
$V_{VS} = V_{VSX} \geq 12.0V, V_{BRX} = 0V$						
Parameter	Symbol	Conditions	Min	Typ	Max	Unit
N-channel MOSFET resistance	R_{ONN}	$T_J = 25^\circ C$		100	150	m Ω
P-channel MOSFET resistance	R_{ONP}	$T_J = 25^\circ C$		160	210	m Ω
N-channel MOSFET resistance	R_{ONN}	$T_J = 150^\circ C$		164		m Ω
P-channel MOSFET resistance	R_{ONP}	$T_J = 150^\circ C$		262		m Ω

Internal MOSFETs TMC261C		DC Characteristics				
$V_{VS} = V_{VSX} \geq 12.0V, V_{BRX} = 0V$						
Parameter	Symbol	Conditions	Min	Typ	Max	Unit
N-channel MOSFET resistance	R_{ONN}	$T_J = 25^\circ C$		90	140	m Ω
P-channel MOSFET resistance	R_{ONP}	$T_J = 25^\circ C$		170	225	m Ω
N-channel MOSFET resistance	R_{ONN}	$T_J = 150^\circ C$		150		m Ω
P-channel MOSFET resistance	R_{ONP}	$T_J = 150^\circ C$		280		m Ω

Clock Oscillator and CLK Input		Timing Characteristics				
Parameter	Symbol	Conditions	Min	Typ	Max	Unit
Clock oscillator frequency	f_{CLKOSC}	$t_J = -50^\circ C$	10.0	13.5		MHz
Clock oscillator frequency	f_{CLKOSC}	$t_J = 50^\circ C$	10.8	14.3	17.5	MHz
Clock oscillator frequency	f_{CLKOSC}	$t_J = 150^\circ C$		14.5	18.0	MHz
External clock frequency (operating)	f_{CLK}	Typ. at 40%/60% dutycycle, Max at 50% dutycycle	4	10-16	20	MHz
External clock high / low level time	t_{CLK}		16			ns
External clock first pulse to trigger switching to external CLK	t_{CLKH} / t_{CLKL}		16			ns
External clock transition time	t_{TRCLK}	V_{INLO} to V_{INH} or back			20	ns
External clock timeout detection in cycles of internal f_{CLKOSC}	$x_{timeout}$	External clock stuck at low or high	32		48	cycles f_{CLKOSC}

Detector Levels		DC Characteristics				
Parameter	Symbol	Conditions	Min	Typ	Max	Unit
V _{VS} undervoltage threshold high	V _{UV}	EN_PFD=0	6.5	7	7.5	V
V _{VS} undervoltage threshold low	V _{UV}	EN_PFD=1	3.25	3.8	4.25	V
V _{VCC_IO} undervoltage threshold for RESET	V _{UV_VIO}	V _{VCC_IO} rising (delay typ. 10µs)	2.1	2.55	3.0	V
V _{VCC_IO} undervoltage detector hysteresis	V _{UV_VIOHYS T}			0.3		V
Short to GND detector threshold (high setting) (V _{VS} - V _{BMx})	V _{BMS2G}		1.2	1.7	2.3	V
Short to GND detector threshold (sensitive setting) (V _{VS} - V _{BMx})	V _{BMS2G}		0.7	1.0	1.3	V
Short to VS detector threshold (V _{BMx})	V _{BMS2VS}		1.3	1.5	1.8	V
Short to GND detector delay (low-side gate off detected to short detection)	t _{S2G}	TS2G=00	2.0	3.2	4.5	µs
		TS2G=10		1.6		µs
		TS2G=01		1.2		µs
		TS2G=11		0.8		µs
Overtemperature warning	t _{OTPW}		85	100	115	°C
Overtemperature release	t _{OTR}	Temperature falling		120		°C
Overtemperature shutdown lo	t _{OTL}	Temperature rising		136		°C
Overtemperature shutdown hi	t _{OTH}	Temperature rising	135	150	170	°C

Sense Resistor Voltage Levels		DC Characteristics				
Parameter	Symbol	Conditions	Min	Typ	Max	Unit
Sense input peak threshold voltage (low sensitivity)	V _{SRTRIPL}	VSENSE=0 Cx=248; Hyst.=0	310	323	340	mV
Sense input peak threshold voltage (high sensitivity)	V _{SRTRIPH}	VSENSE=1 Cx=248; Hyst.=0	155	173	190	mV

Digital Logic Levels		DC Characteristics				
Parameter	Symbol	Conditions	Min	Typ	Max	Unit
Input voltage low level ^{a)}	V _{INLO}		-0.3		0.3 V _{VIO}	V
Input voltage high level ^{a)}	V _{INHI}		0.7 V _{VIO}		V _{VIO} +0.3	V
Output voltage low level	V _{OUTLO}	I _{OUTLO} = 2mA			0.2	V
Output voltage high level	V _{OUTH}	I _{OUTH} = -2mA	V _{VIO} -0.2			V
Input leakage current	I _{I LEAK}		-10		10	µA
Digital pin capacitance	C			3.5		pF

Notes:

- a) Digital inputs left within or near the transition region substantially increase power supply current by drawing power from the internal 5V regulator. Make sure that digital inputs become driven near to 0V and up to the V_{VIO} I/O voltage. There are no on-chip pull-up or pull-down resistors on inputs.

19.3 Thermal Characteristics

Please refer to TMC2660-EVAL for a sample layout. The TMC2660 shares the same structure and footprint as the TMC260 / TMC261

Parameter	Symbol	Conditions	Typ	Unit
Thermal resistance bridge transistor junction to ambient, soldered to 4 layer 20cm ² PCB (or 20cm ² size per driver IC for multiple driver board)	R _{THA14}	one bridge chopping, fixed polarity	80	K/W
	R _{THA24}	two bridges chopping, fixed polarity	50	K/W
	R _{THA44}	Motor running	37	K/W
Thermal resistance bridge transistor junction to ambient, soldered to 4 layer 50cm ² PCB	R _{THA44a}	Motor running	28	K/W

When operating the device near its current limits, ensure a good thermal design of the PCB layout to avoid overheating of the integrated power MOSFETs. Due to its multichip-construction with individual heat transfer for each MOSFET of the power stage to the PCB using two pins, thermal characteristics depend on the layout symmetry. The actual thermal resistance also depends on the duty cycle and the die temperature. Use the thermal characteristics and the sample layout as a guideline for your own board layout. In case, the driver is to be operated at high current levels, special care should be taken to spread the heat generated by the driver power bridges efficiently within the PCB.

The worst-case thermal resistance occurs during motor stand still with the motor stopped in a half step position (one coil full current, other coil 0 current), as well as cyclic in slow motion below 4FS/s. Assume roughly 80°C/W, when there is only one bridge chopping. This is the worst-case scenario for heat-up. In stand still, with two bridges chopping at identical current (fullstep position), thermal resistance is reduced, because the power dissipation is distributed to more MOSFETs. Reduce stand still current to 68% or less, to compensate for both stand still scenarios. When the motor is running, calculate thermal resistance for the complete chip (all 8 MOSFETs working).

The MOSFET and bond wire temperature should not exceed 150°C, despite temperatures up to 200°C will not immediately destroy the devices. But the package plastics will apply strain onto the bond wires, so that cyclic, repetitive exposure to temperatures above 150°C may damage the electrical contacts and increase contact resistance and eventually lead to contract break. As the MOSFET temperatures cannot be monitored within the system, it is a good practice to react to the temperature pre-warning by reducing motor current, rather than relying on the overtemperature switch off.

Check MOSFET temperature under worst case conditions not to exceed 150°C using a thermal camera to validate your layout. Please carefully check your layout against the sample layout or the layout of the TMC2660-Evaluation board on the TRINAMIC website in order to ensure proper cooling of the IC!

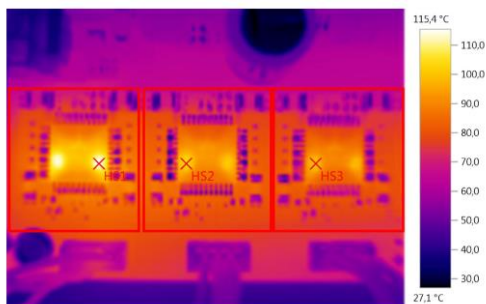

Figure 19.1 One TMC260 operating at 1.4A RMS (2A peak), other TMC260 devices at 1.1A RMS

20 Package Mechanical Data

20.1 Dimensional Drawings

Attention: Drawings not to scale.

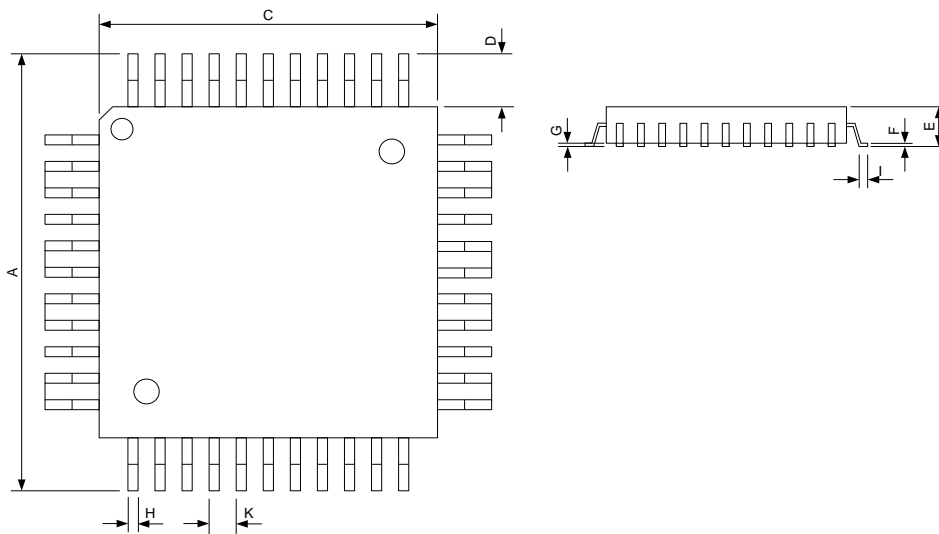

Figure 20.1 Dimensional drawings (PQFP44)

Parameter	Ref	Min	Nom	Max
Size over pins (X and Y)	A		12	
Body size (X and Y)	C		10	
Pin length	D		1	
Total thickness	E			1.6
Lead frame thickness	F	0.09		0.2
Stand off	G	0.05	0.10	0.15
Pin width	H	0.30		0.45
Flat lead length	I	0.45		0.75
Pitch	K		0.8	
Coplanarity	ccc			0.08

20.2 Package Code

Device	Package	Temperature range	Code/markings
TMC260C	PQFP44 (RoHS)	-40° to +125°C	TMC260C-PA
TMC261C	PQFP44 (RoHS)	-40° to +125°C	TMC261C-PA

21 Disclaimer

TRINAMIC Motion Control GmbH & Co. KG does not authorize or warrant any of its products for use in life support systems, without the specific written consent of TRINAMIC Motion Control GmbH & Co. KG. Life support systems are equipment intended to support or sustain life, and whose failure to perform, when properly used in accordance with instructions provided, can be reasonably expected to result in personal injury or death.

Information given in this data sheet is believed to be accurate and reliable. However, no responsibility is assumed for the consequences of its use nor for any infringement of patents or other rights of third parties which may result from its use.

Specifications are subject to change without notice.

All trademarks used are property of their respective owners.

22 ESD Sensitive Device

The TMC260 and the 261 are ESD-sensitive CMOS devices and sensitive to electrostatic discharge, due to discrete MOSFETs integrated into the package. Take special care to use adequate grounding of personnel and machines in manual handling. After soldering the devices to the board, ESD requirements are more relaxed. Failure to do so can result in defects or decreased reliability.



Note: In a modern SMD manufacturing process, ESD voltages well below 100V are standard. A major source for ESD is hot-plugging the motor during operation. As the power MOSFETs are discrete devices, the device in fact is very rugged concerning any ESD event on the motor outputs. All other connections are typically protected due to external circuitry on the PCB.

23 Designed for Sustainability

Sustainable growth is one of the most important and urgent challenges today. We at Trinamic try to contribute by designing highly efficient IC products, to minimize energy consumption, ensure best customer experience and long-term satisfaction by smooth and silent run, while minimizing the demand for external resources, e.g. for power supply, cooling infrastructure, reduced motor size and magnet material by intelligent control interfaces and advanced algorithms.

Please help and design efficient and durable products made for a sustainable world.

24 Table of Figures

Figure 1.1 applications block diagram.....	4
Figure 2.1 TMC260/261 pin assignments (top view).....	6
Figure 3.1 TMC260 and TMC261 block diagram.....	8
Figure 2 Standalone configuration.....	9
Figure 5.1 StallGuard2 load measurement SG as a function of load.....	10
Figure 5.2 Linear interpolation for optimizing SGT with changes in velocity.....	11
Figure 6.1 Energy efficiency example with CoolStep.....	13
Figure 6.2 CoolStep adapts motor current to the load.....	14
Figure 7.1 SPI Timing.....	16
Figure 7.2 Interfaces to a TMC429 motion controller chip and a TMC260 or TMC261 motor driver.....	17
Figure 8.1 STEP and DIR timing.....	28
Figure 8.2 Internal microstep table showing the first quarter of the sine wave.....	29
Figure 8.3 MicroPlyer microstep interpolation with rising STEP frequency.....	30
Figure 9.1 Sense resistor grounding and protection components.....	33
Figure 10.1 Chopper phases.....	34
Figure 10.2 No ledges in current wave with sufficient hysteresis (magenta: current A, yellow & blue: sense resistor voltages A and B).....	36
Figure 10.3 spreadCycle chopper mode showing the coil current during a chopper cycle.....	37
Figure 10.4 Constant off-time chopper with offset showing the coil current during two cycles.....	38
Figure 10.5 Zero crossing with correction using sine wave offset.....	38
Figure 12.1 Short detection timing.....	41
Figure 12.2 Undervoltage reset timing.....	44
Figure 14.1 Start-up requirements of CLK input.....	46
Figure 3.10 Simple ESD enhancement and more elaborate motor output protection.....	48
Figure 16.1 Layout example for TMC260 and TMC261.....	50
Figure 18.1 One TMC260 operating at 1.4A RMS (2A peak), other TMC260 devices at 1.1A RMS.....	55
Figure 19.1 Dimensional drawings (PQFP44).....	56

25 Revision History

Version	Date	Author BD – Bernhard Dwersteg	Description
1.00	2020-JUL-07	BD	New version for -C types. Non-C-type information only for reference
1.01	2020-AUG-11	BD	Correction of pin list
1.02	2021-JUN-17	BD	Added EME example, minor fixes

26 References

- [TMC262] TMC262 Datasheet (please refer to our homepage <http://www.trinamic.com>)
 [TMC429+TMC26x-EVAL] TMC429+TMC26x-EVAL Evaluation Board Manual