

NXP S12 MAGNIV OVERVIEW

TONY ZHANG / 张剑龙

FILED APPLICATION ENGINEER

MAY. 04, 2017



EXTERNAL USE



SECURE CONNECTIONS
FOR A SMARTER WORLD

NXP AMP Product Lines

C&S

(Connectivity & Security)

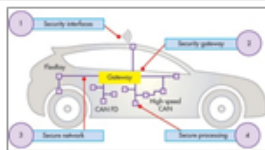

Gateway

- #1 in Vehicle Networking with leading networking and security IP
- #1 in Automotive HW Security with Strong IP and broad portfolio
- End to end portfolio of networking devices (MCU/MPU, TX/RX)

Products:
MPC564xB/C
MPC574xG

ADAS

(Advanced Driver Assistance Systems)



Radar, LIDAR Vision Sensor Fusion

- #1 in Radar with strong IP and system knowledge
- High performance low power accelerators
- Scalable high performance roadmap for central processing

Products:
• S32R - Radar
• S32V - Vision

VDS

(Vehicle Dynamics & Safety)



Chassis & Safety Powertrain & Hybrid/EV

- Long term Innovator in Chassis and Powertrain Control.
- Significant Growth in Safety as Autonomous Control Drives Robust Fault Tolerant Systems

Products:
MPC56xx
MPC57xx

GPIS

(General Purpose & Integrated Solutions)



Body Electronics Edge Nodes

- 500+ customers
- Broadest portfolio of integrated MCU+HV mixed-signal solutions
- Complete Tools & Software enablement

Products:
S08/S12/PPC → ARM
KEA - S32K
S12 MagniV - S32M

General Purpose and Integrated Solutions

Target Markets

General Purpose

Body Electronics
Lighting



HVAC



Other



Integrated Solutions

Motor Control
Window Lift



Pumps, Fans



Sensor Interfaces



Products

ARM

KEA - S32K

The First Automotive MCU
Designed for Software Engineers

S08 - S12 - MPC56xxB/C (Bolero)

- Shipping ~500Mu in 2016
- 8/16/32bit proven architectures

S12 MagniV

Shrink your application with MCU
+ HV analog integration

Technology

Software and
Tools

Moving to ARM
Cortex Architecture

HV Analog
integration
ASSP

General Purpose
Integrated

MagniV Concept: Shrink Your Application

Integration of High-Voltage (HV) Analog Features into a Standard Automotive MCU

Traditional Solution

- Standard MCU
- Multiple analog ICs

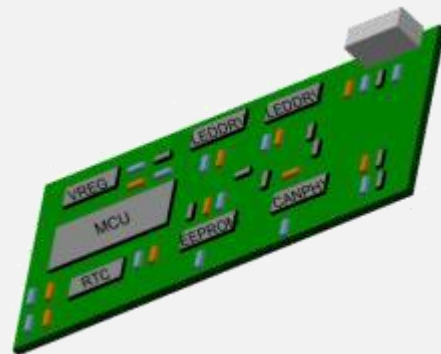

MagniV

- Single device
- Reduced space

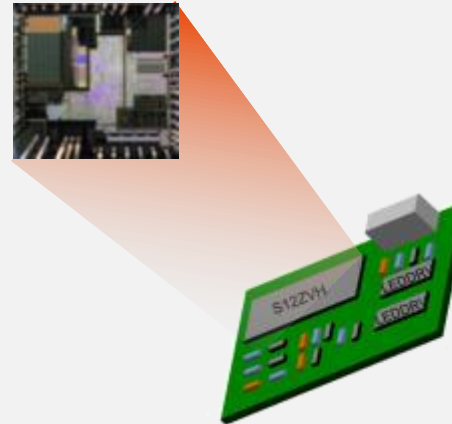

15+ Years of System in Package (SiP) Experience

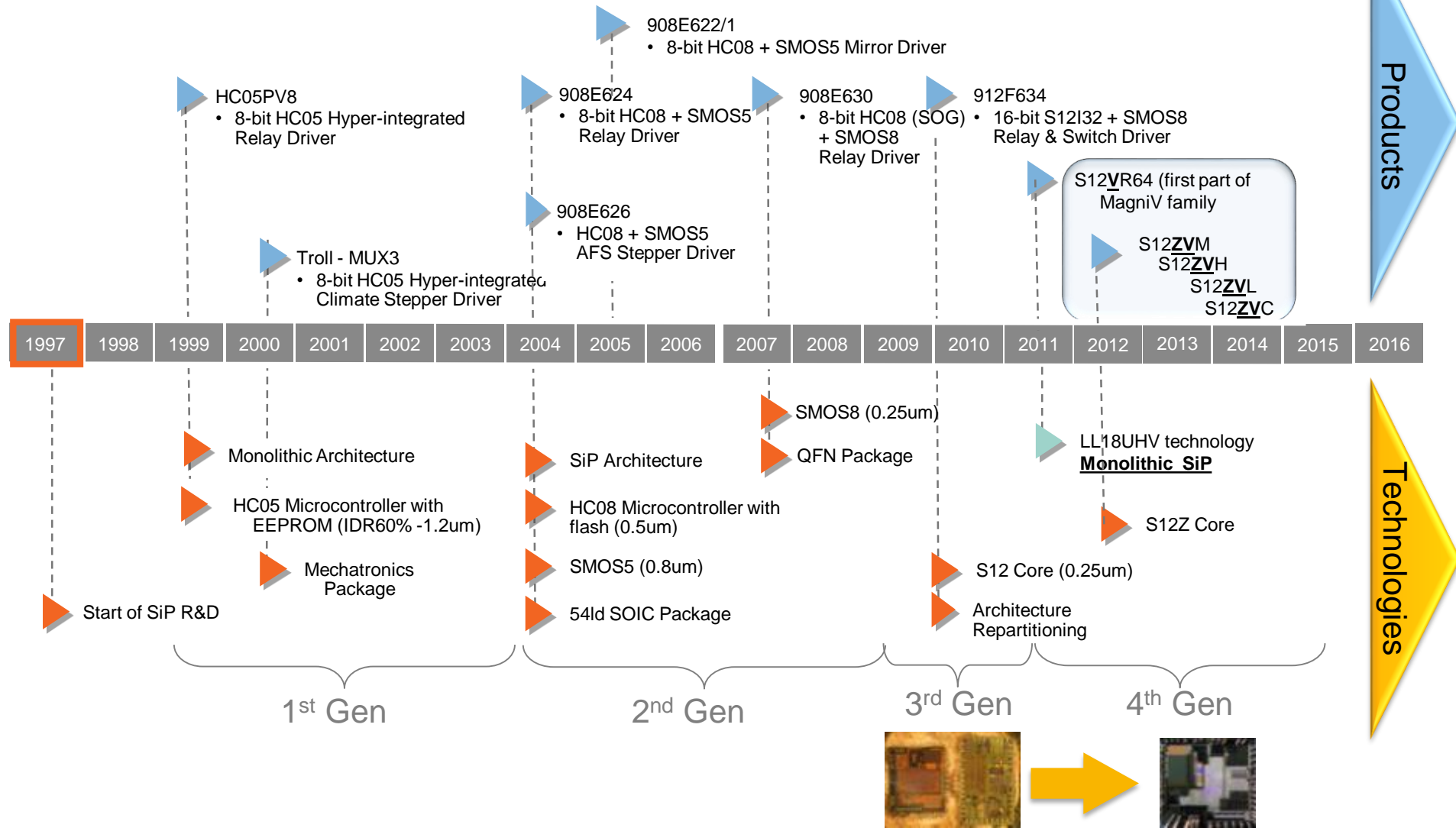

A Technology Sweet-spot for Sensor and Actuators

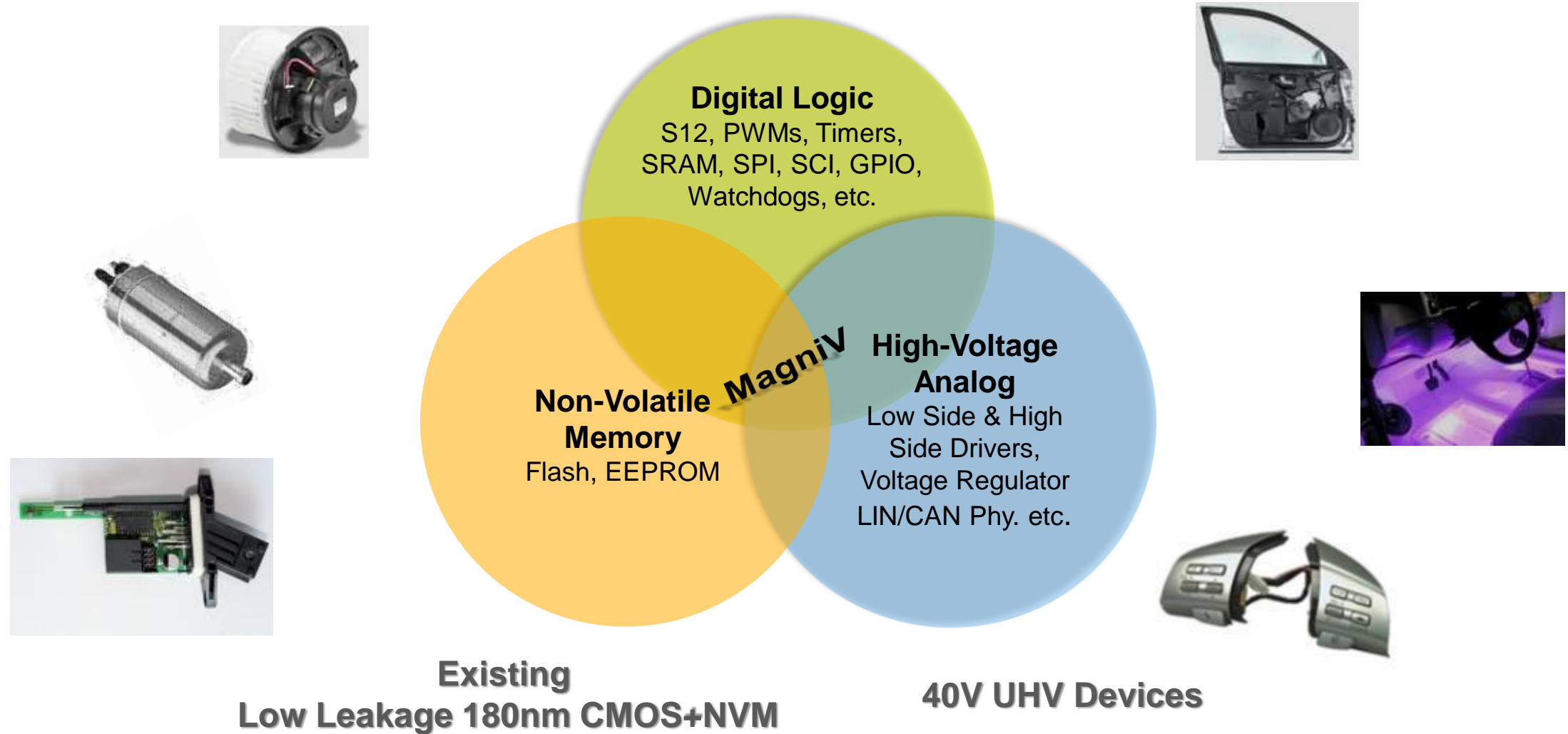

MagniV building blocks

High-Voltage Components	Digital Components	MCU Core and Memories	5V Analogue Components	Packaging
VREG for tot. supply: •70mA w/o ext comp. or •170mA with ext. ballast	MSCAN Sent	S12- or S12Z-CPU 25/32/50MHz bus	List Based ADC 10-12Bit resolution 1-2 S/H-units Up to 16ch total	LQFP: 32/48/64/100/144-pin
LIN-PHY CAN-PHY	SCI SPI IIC	Flash (ECC) 8kB – 192kB	Temp Sense	LQFP-EP:  48/64-pin
V-BAT SENSE V-SUP SENSE	GPIO PGPIO 20mA NGPIO 25mA	EEPROM (ECC) 128B – 4kB	Current Sense (2 x Op-Amp)	QFN: 32-pin (5x5mm)
1-4ch HVI (12V-input with wake-up and ADC)	BDM/BDC	RAM (ECC) 512B - 8kB	2ch ACMP With 1x6-Bit-DAC	
LS-drivers HS-drivers	Key Wakeups Win Wdog		Pierce Osc.	
Charge Pump	RTC		32kHz low power Osc	
4-6ch Gate Drive Unit for FET Qg=50-150nC	Timer 16Bit (25-64MHz) PWM 8/16Bit (25-64MHz)		RCosc. +/-1.3% PLL	
	Motorcontrol PWM With Fault protection			
	Programmable Trigger Unit			
	Sound Generator			
	Segment LCD (4x40)			
	Stepper Motor Driver with SSD			

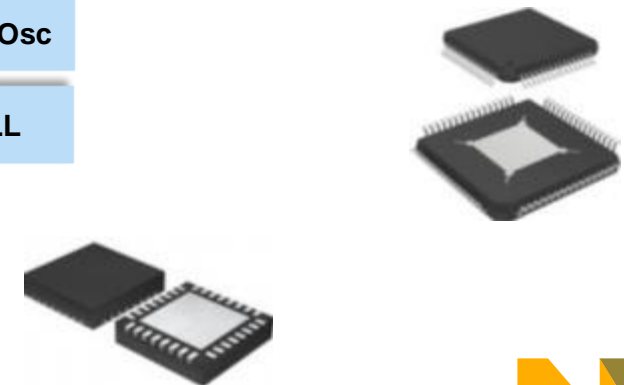

MagniV: Integration Benefits

- **Reduced size**
 - Smaller PCB
 - Smaller housing
 - Increased design flexibility
- **Fewer components**
 - Fewer devices to pick and place
 - Fewer solder joints
- **Fewer test points**
 - Integration offers a pre-tested subsystem
- **Quality**
 - Fewer points of failure
- **Simplified Logistics**
 - Fewer parts to qualify, source, store, track



S12 MagniV: A Way To Shrink Your Automotive Application

S12 MagniV simplifies system design with the integration on High-Voltage (HV) analog features onto MCUs for automotive applications

S12VR
Relay driven motors

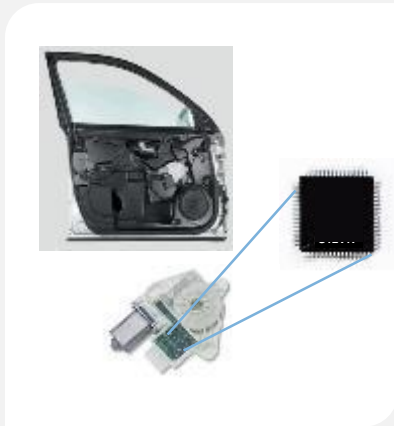

S12ZVM
BLDC/DC motors

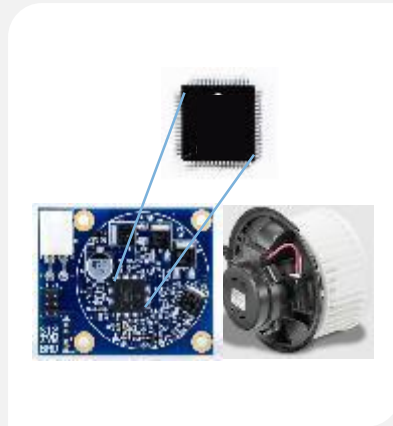

S12ZVC
Small CAN nodes

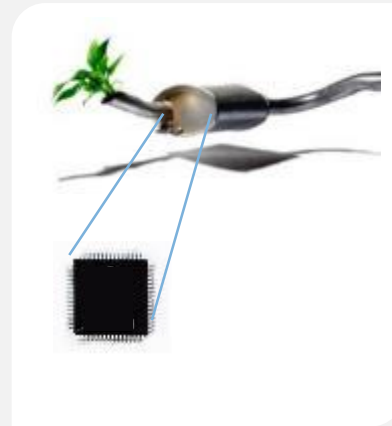

S12ZVL
LIN Nodes

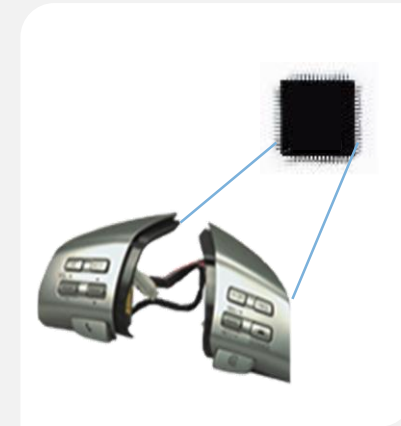

- ✓ Reduced PCB Space
- ✓ Reduced Bill of Material
- ✓ Improved manufacturing efficiency and quality
- ✓ Simplified development

SafeAssure™ Program: MagniV

Safety Hardware

Common safe hardware platform for application software:

- Voltage/clocks monitoring
- Memories w/ error correction
- Window Watchdog...

Safety Process

- ISO26262 development process for most products
- Safety-Element-Out-Of-Context



Safety Support

- FIT rates
- Dynamic FMEDA
- Safety manual
- Technical support as required

Safety Software

S12Z core self-test available to complement the built-in hardware safety features

Product families	Development Process	FMEDA Report Availability	Dependant Failure Analysis	Safety Manual	Core Self test and User Guide	
S12VR	Standard	Upon request	Yes	No	No	
S12VR	Standard	Upon request		No	No	
S12ZVM	Standard	yes		Yes	Yes (www)	Yes
S12ZVM	ISO 26262	Q4 2014		Yes	Yes (www)	Yes
S12ZVL	ISO 26262	yes		Yes	Yes (www)	Yes
S12ZVC	ISO 26262	yes		Yes	Yes (www)	Yes

MagniV Conformance Testing

Device	S12VRxx	S12ZVMxx	S12ZVLxx	S12ZVCxx
Interface	LIN	LIN	LIN	CAN
CAN / LIN conformance C&S	LIN 2.2: PASS SAE J2602-2: PASS	LIN 2.2: PASS SAE J2602-2: PASS	LIN 2.2: PASS SAE J2602-2: PASS	CAN PL: PASS
EMC/ESD IBEE Zwickau German OEMs	PASS	PASS	PASS	PASS
EMC/ESD ULLabs / Mooser US OEMs	PASS	PASS	PASS	PASS
CAN Conformance Velio Japanese OEMs	n/a			PASS

MagniV Integrated Solutions Roadmap

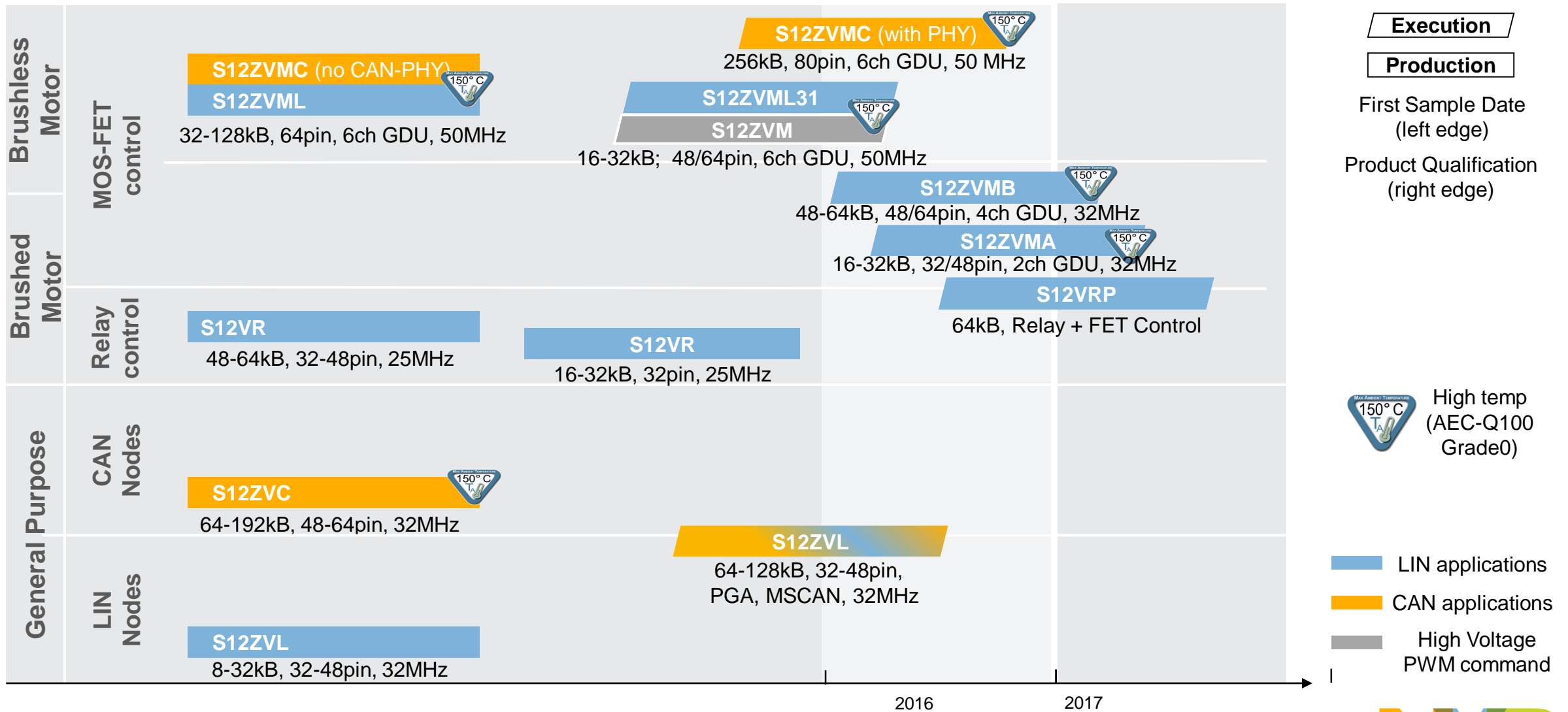

Execution

Production

First Sample Date (left edge)

Product Qualification (right edge)





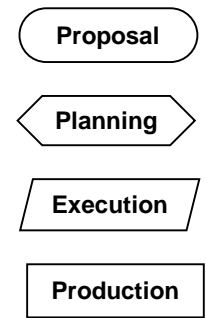
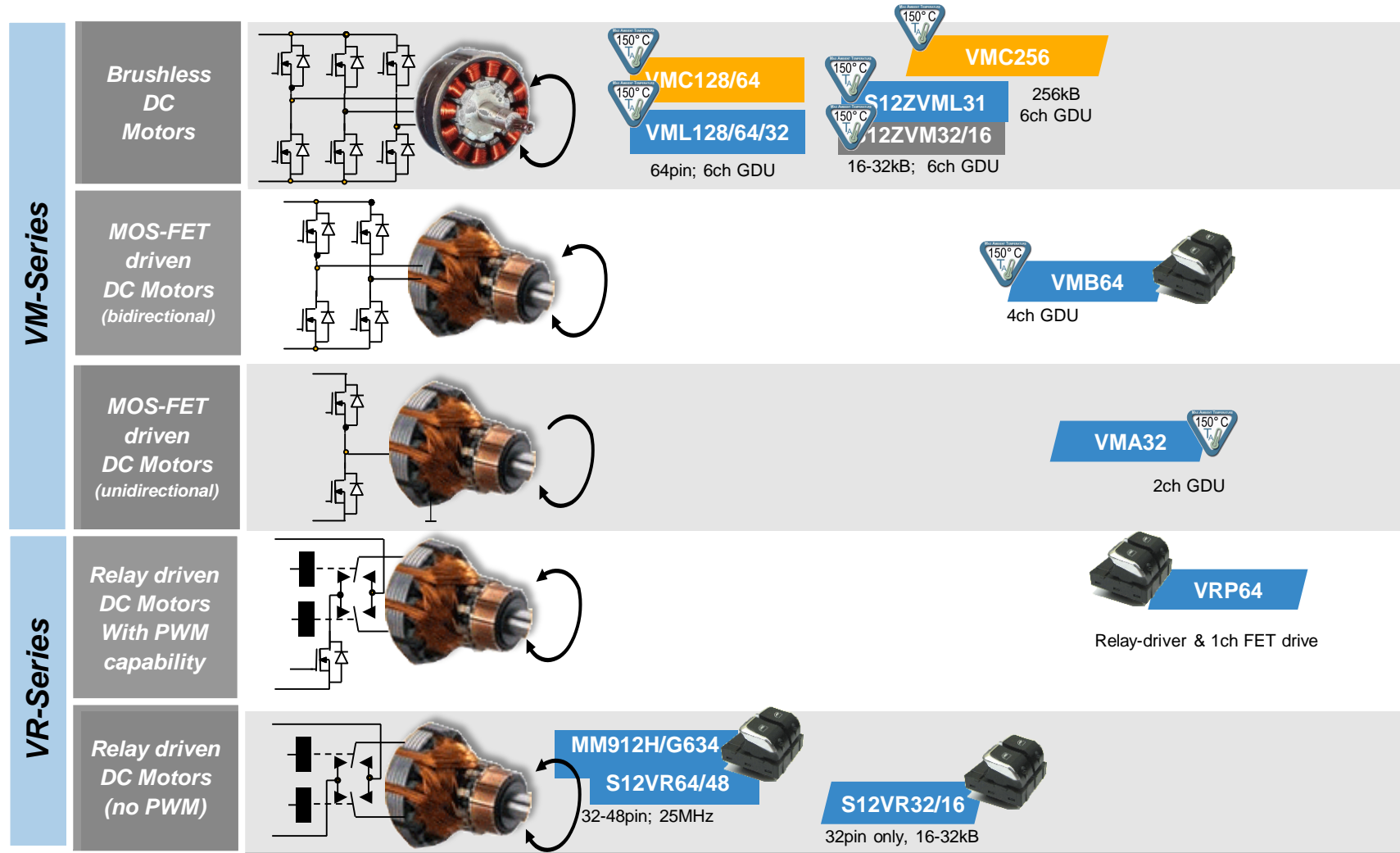

High temp (AEC-Q100 Grade0)

- LIN applications
- CAN applications
- High Voltage PWM command



S12 MagniV: Motor Control / Actuator Lineup



-  LIN applications
-  CAN applications
-  High voltage PWM controlled applications
-  High temp option (AEC Grade 0)
-  Switch panel interface (HS-drivers & HVIs)
-  Main usecase:
 - window lift
 - sun roof



S12 MagniV: Motor Control / Actuator Lineup

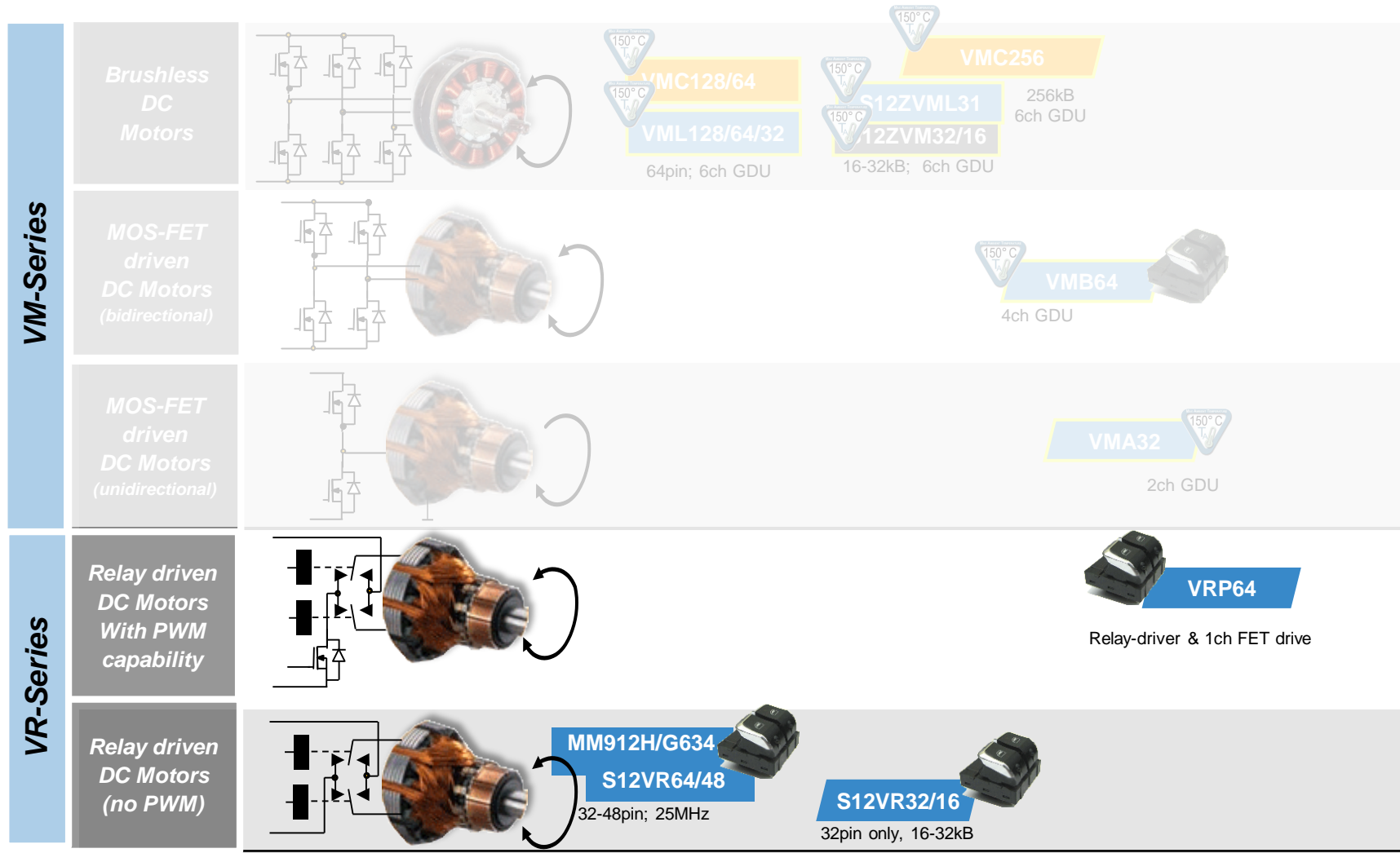

- Proposal
- Planning
- Execution
- Production

- LIN applications
- CAN applications
- High voltage PWM controlled applications
- High temp option (AEC Grade 0)
- Switch panel interface (HS-drivers & HVIs)
- Main usecase:
- window lift
- sun roof



S12VR Application Schematics (Window Lift)

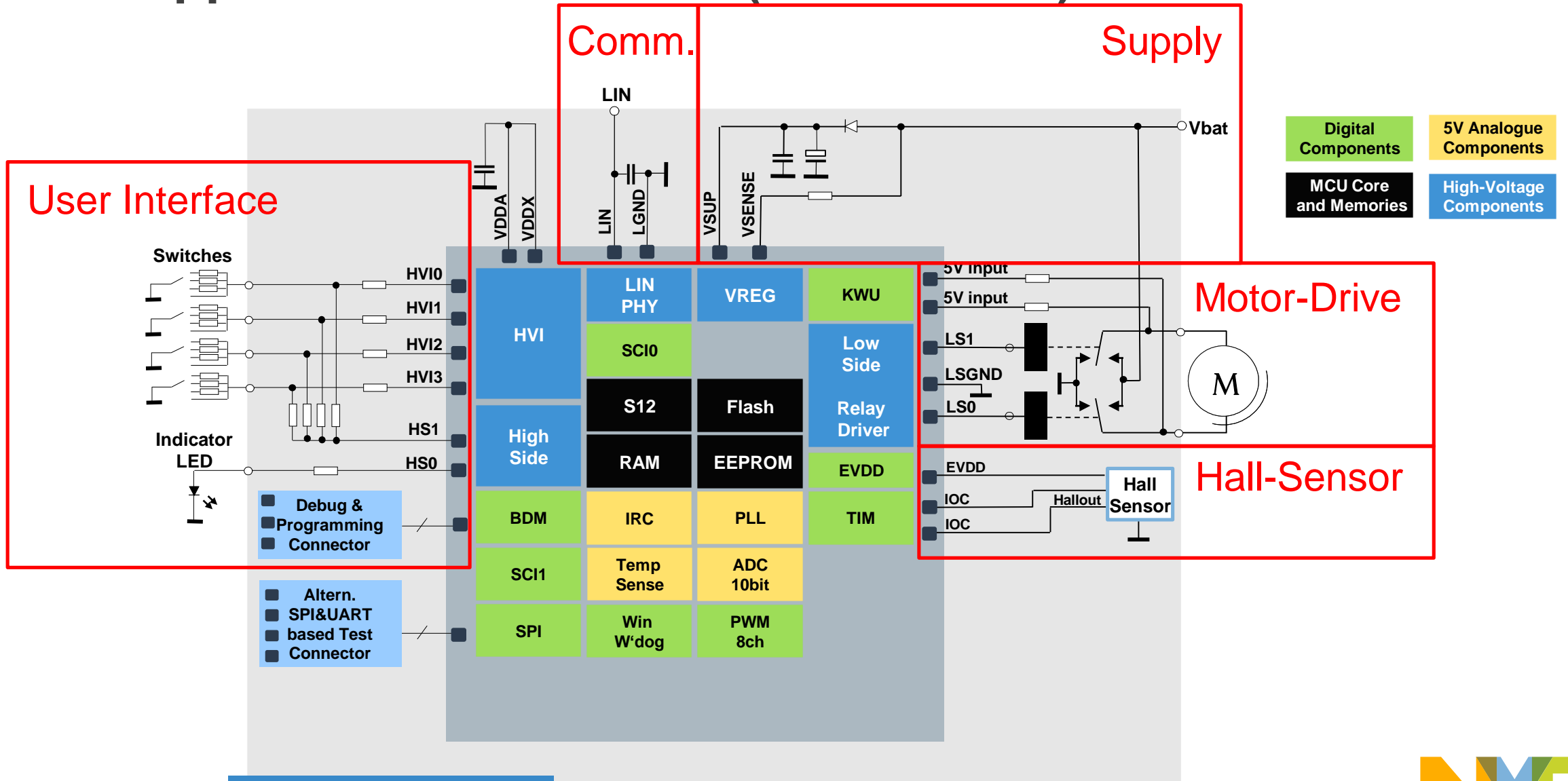

Pinout representing functionality, Physical pins location is different



S12 MagniV : Motor Control / Actuator Lineup

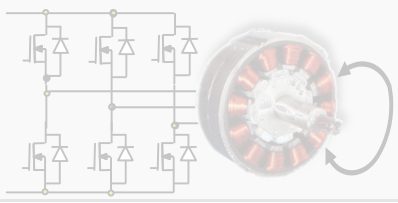
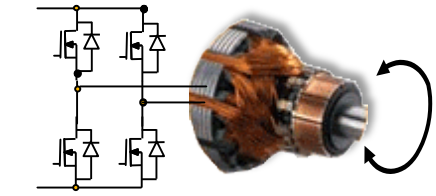
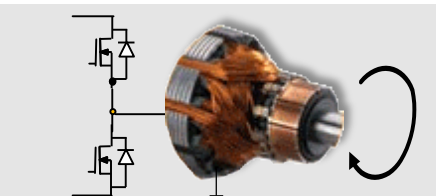
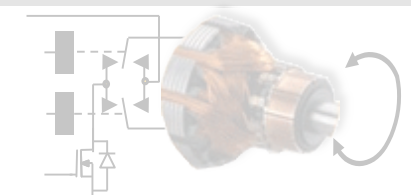
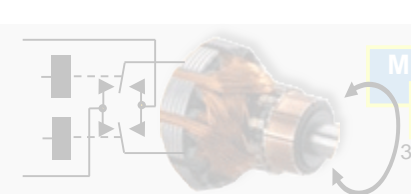

VM-Series	Brushless DC Motors	 <ul style="list-style-type: none"> VMC128/64 (150°C) VML128/64/32 (150°C) S12ZVML31 (150°C) S12ZVM32/16 (150°C) VMC256 (150°C)
	MOS-FET driven DC Motors (bidirectional)	 <ul style="list-style-type: none"> VMB64 (150°C)
	MOS-FET driven DC Motors (unidirectional)	 <ul style="list-style-type: none"> VMA32 (150°C)
VR-Series	Relay driven DC Motors With PWM capability	 <ul style="list-style-type: none"> VRP64
	Relay driven DC Motors (no PWM)	 <ul style="list-style-type: none"> MM912H/G634 S12VR64/48 S12VR32/16

Proposal

Planning

Execution

Production

-  LIN applications
-  CAN applications
-  High voltage PWM controlled applications

 High temp option (AEC Grade 0)

 Switch panel interface (HS-drivers & HVIs)

Main usecase:
- window lift
- sun roof



S12ZVMA Application Schematic

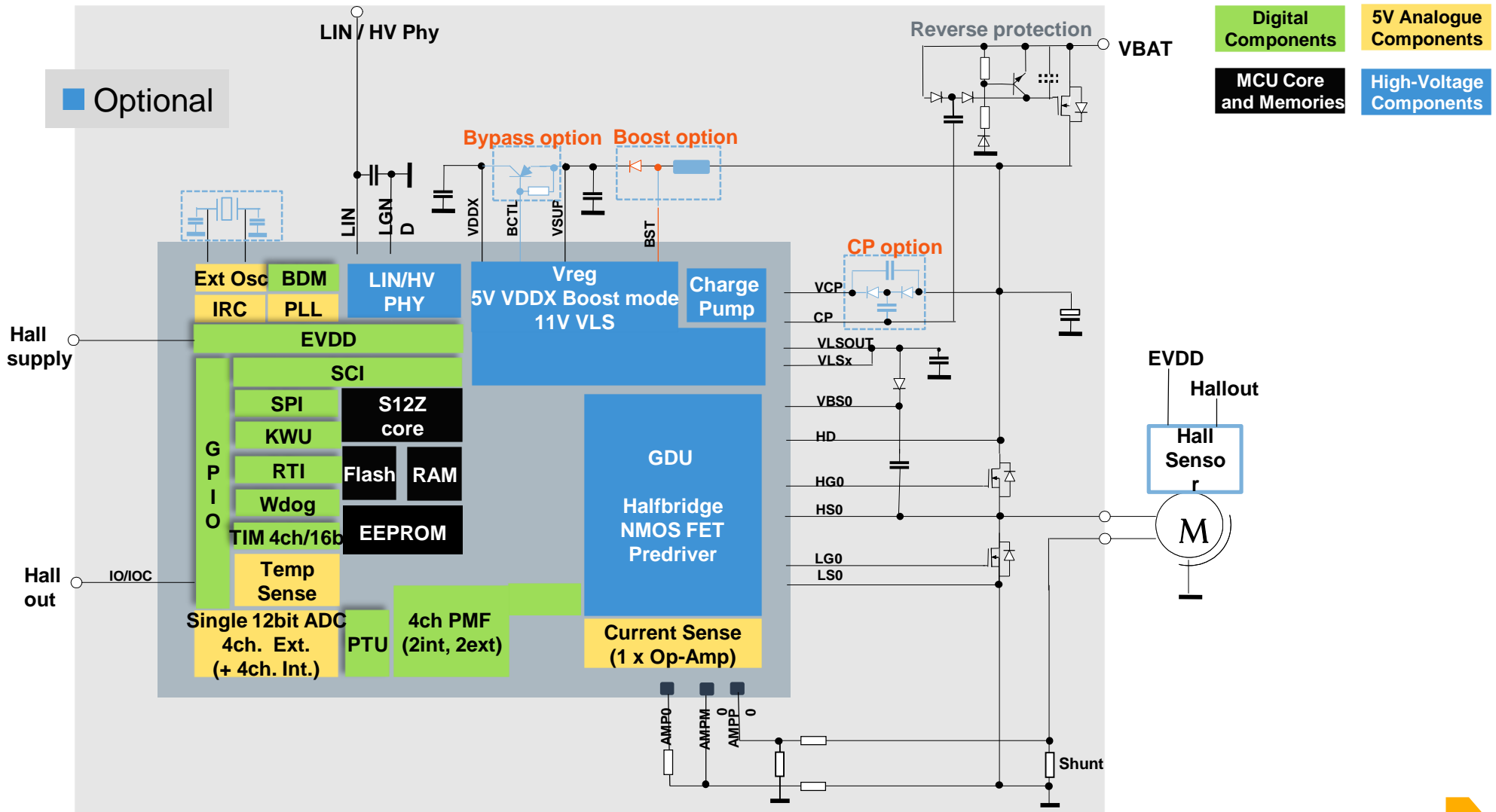

S12ZVMB Application Schematic (Window Lift)

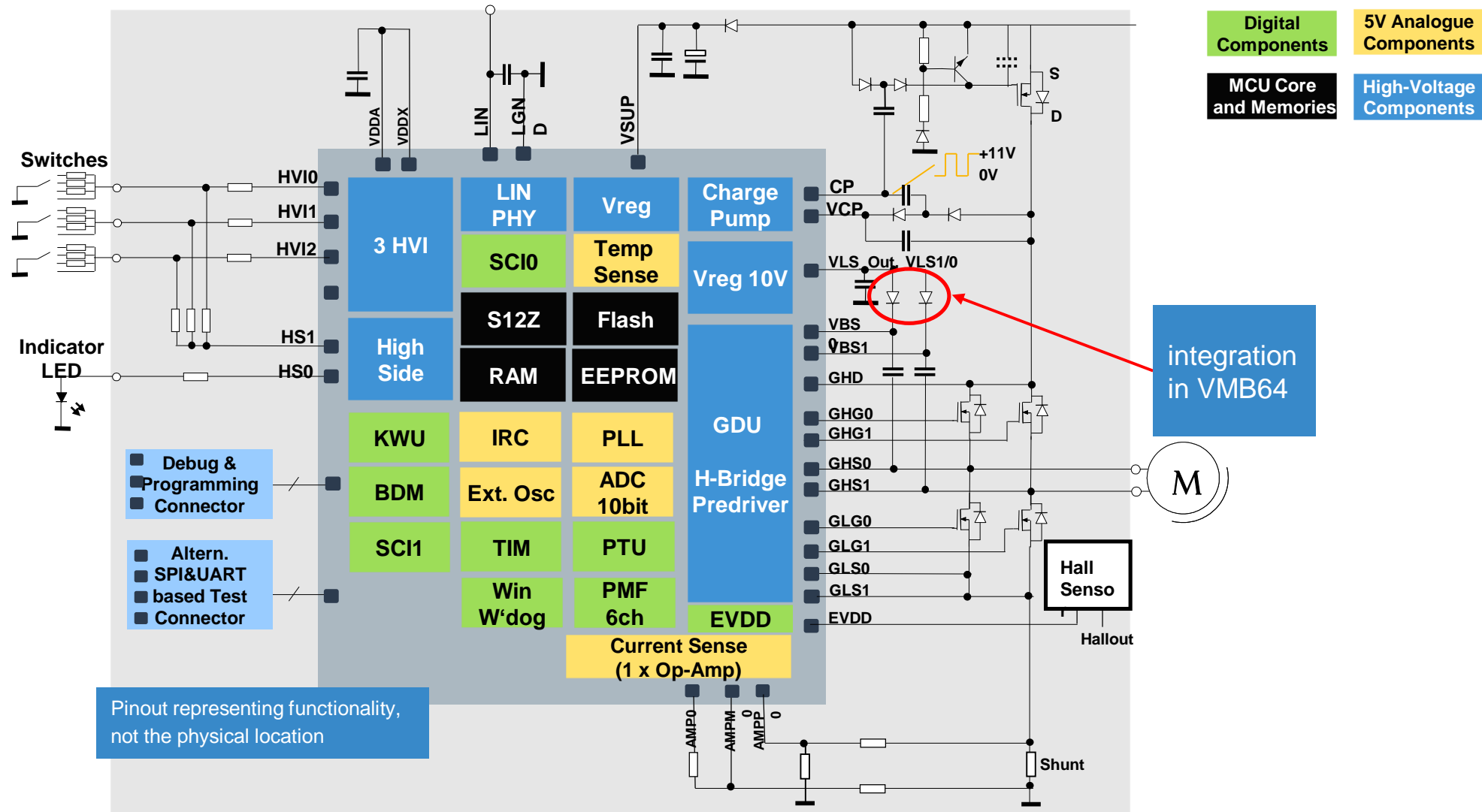

S12 MagniV: Motor Control / Actuator Lineup

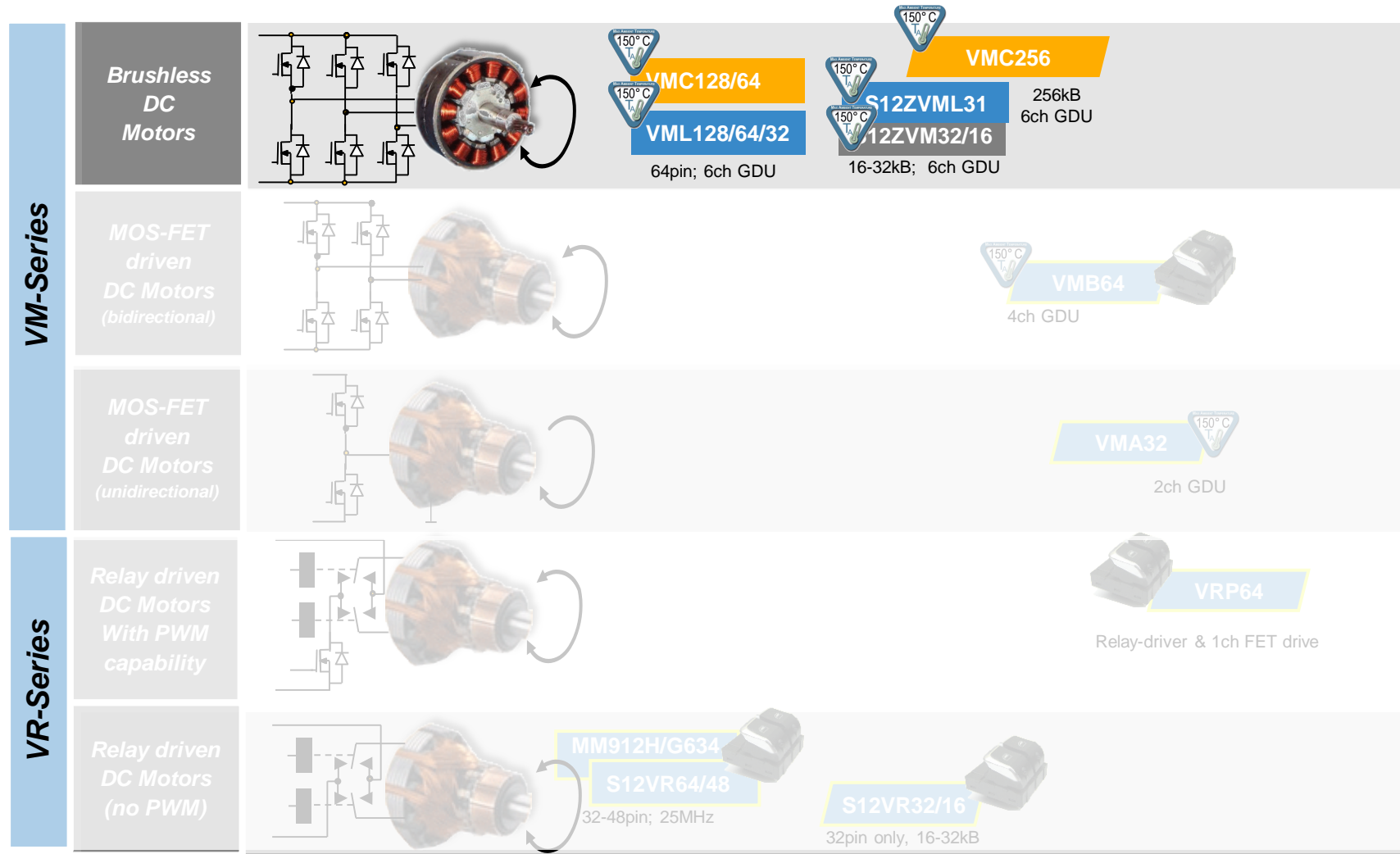

Proposal

Planning

Execution

Production

LIN applications

CAN applications

High voltage PWM controlled applications

High temp option (AEC Grade 0)

Switch panel interface (HS-drivers & HVIs)

Main usecase:
 - window lift
 - sun roof



3-Phase BLDC / PMSM Motors – Market Segmentation



200+W motors

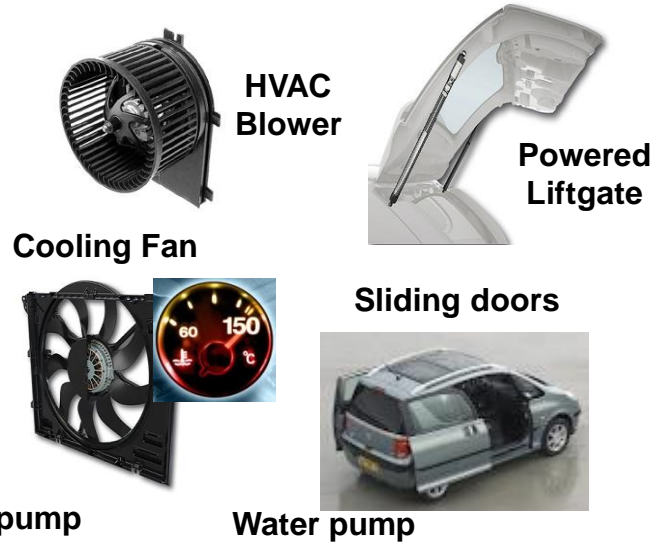

S12ZVML/C (64/128/256kB)
Carcassonne

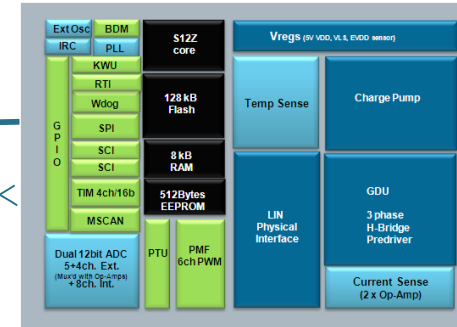

50-200W motors
↓
Reduced GDU drive

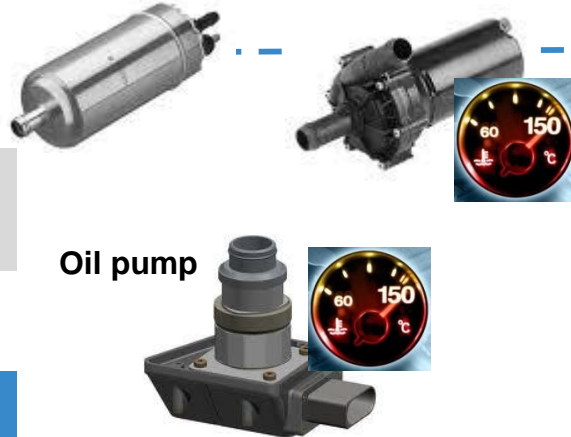

S12ZVM (32kB)
Obidos

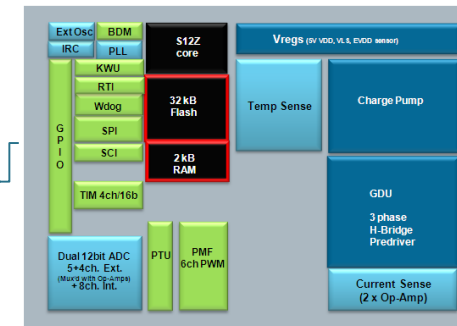

S12ZVML Application Schematic

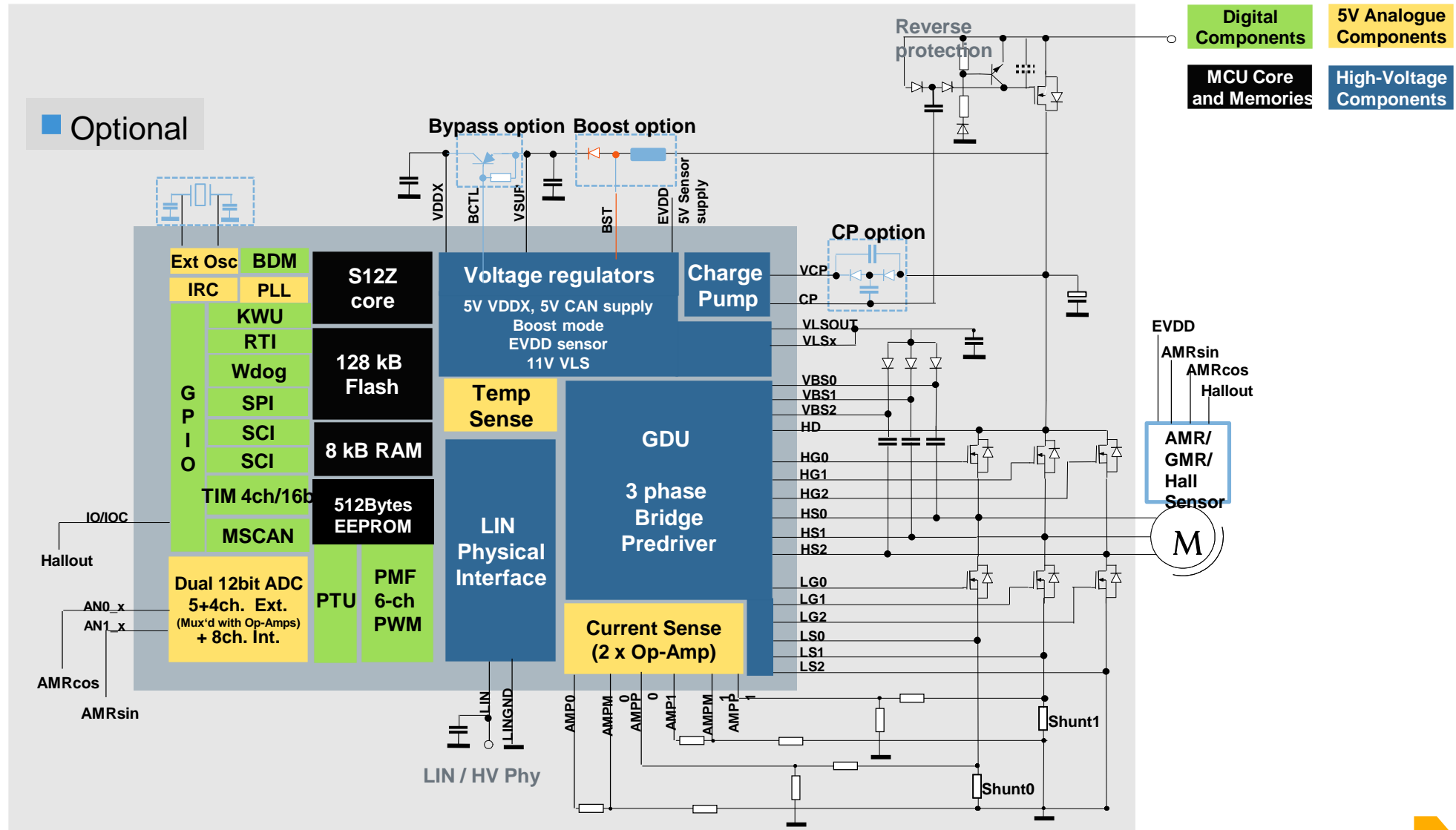

MOTOR CONTROL SOLUTIONS OFFERING



S12ZVM Development Ecosystem

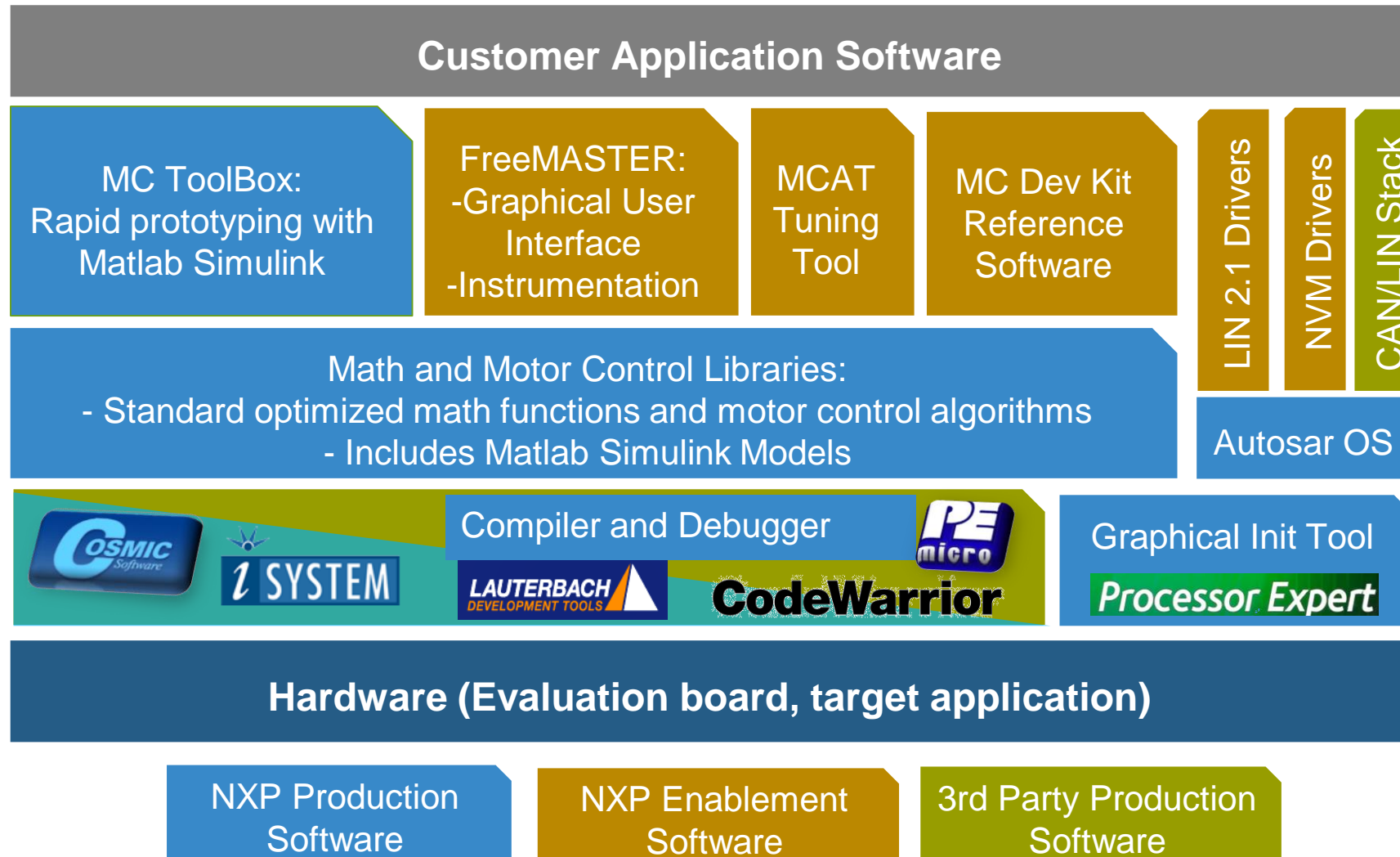

The Complete Solutions Offering For Motor Control

Automotive Math & Motor Control Library Set

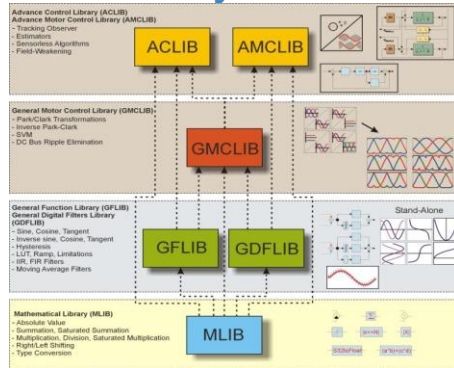

Automotive Motor Control Development Kit Series

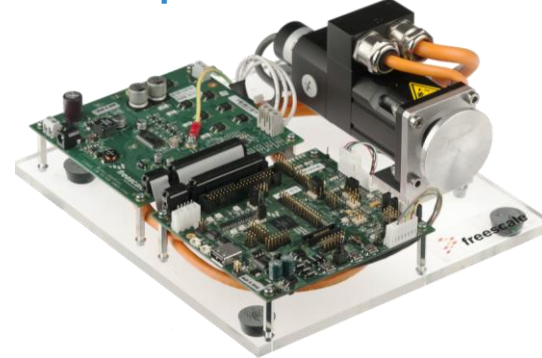

FreeMASTER & Motor Control Application Tuning (MCAT) Tools

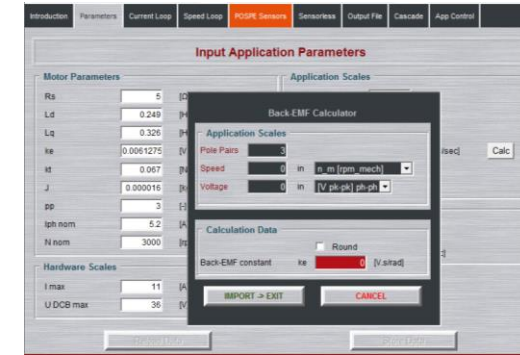

NXP Electric Motor Control Know-how

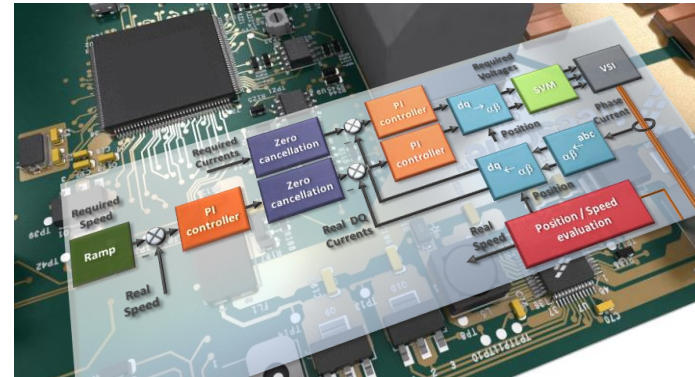

Final customer applications, based on S12 MagniV / MPC / S32K MCU

The Complete Solutions Offering For Motor Control

Automotive Math & Motor Control Library Set

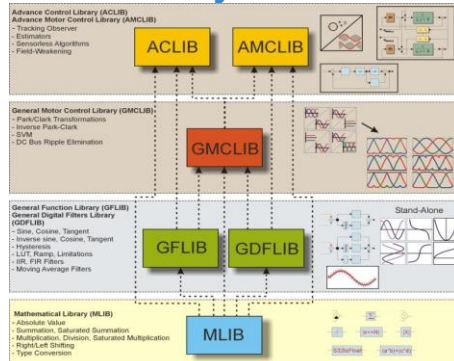

www.nxp.com/AutoMCLib

Automotive Motor Control Development Kit Series



www.nxp.com/AutoMCDevKits

FreeMASTER & Motor Control Application Tuning (MCAT) Tools

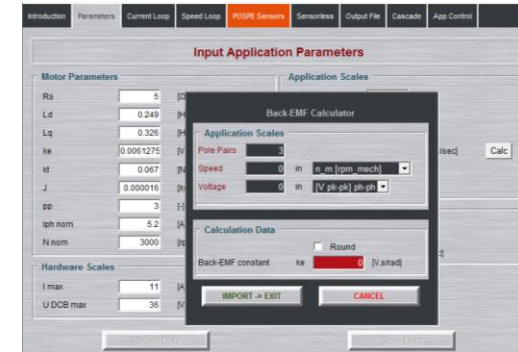

www.nxp.com//FreeMASTER, MCAT

NXP Electric Motor Control Know-how



www.nxp.com/MotorControl

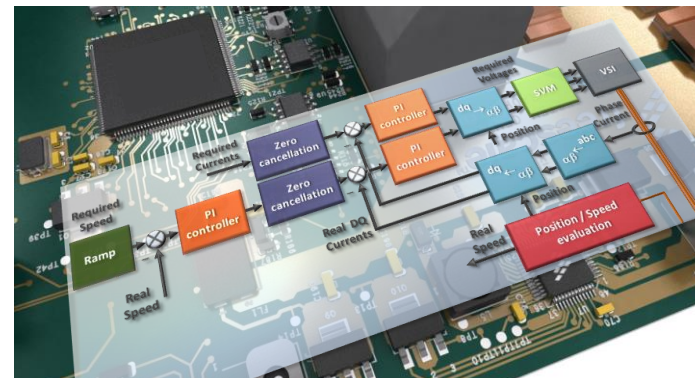

Final customer applications, based on S12 MagniV / MPC / S32K MCU

AMMCLib – Building Blocks for Your Motor Control SW

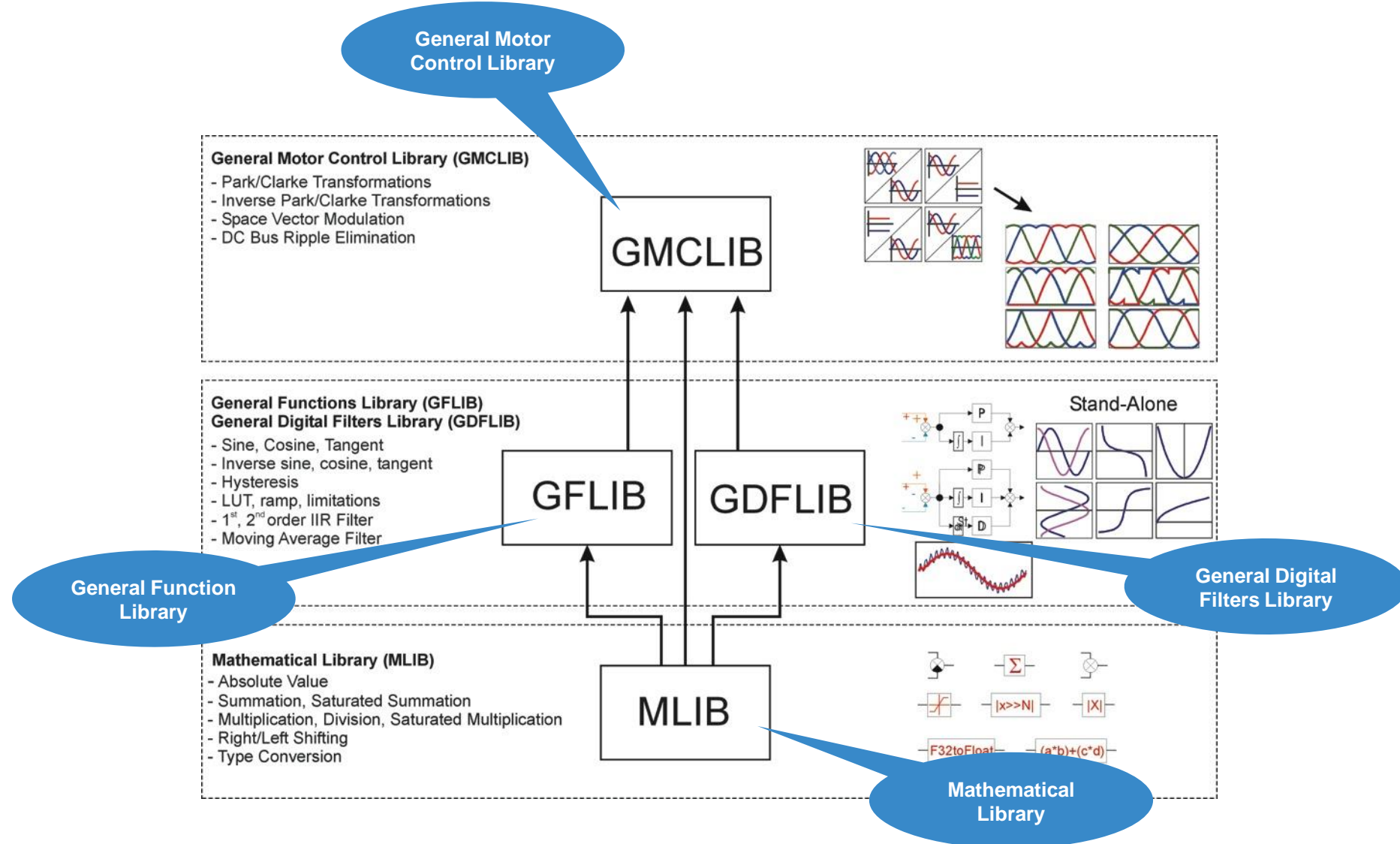

FreeMASTER – “Debugger for Real-Time Applications”

- **Real-Time Data Monitor Tool**

- Read / modify your variables run-time
- Oscilloscope / recorder capability

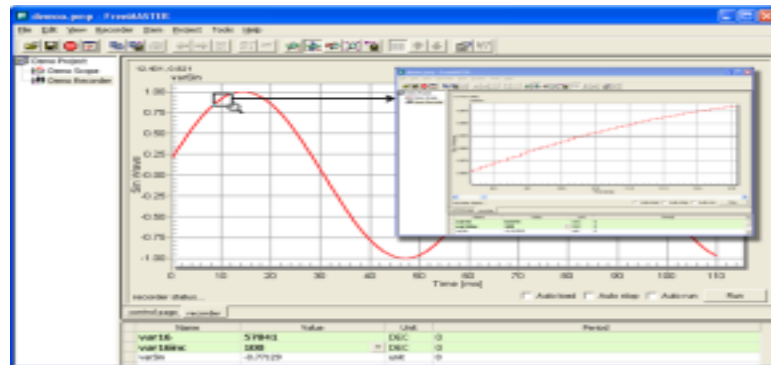

- **Demonstration Platform**

- Create a comprehensive support package for your product



- **Scriptable Graphical User Interface**

- Build your own GUI using sliders, gauges, buttons



www.nxp.com/FreeMASTER

Make Any Motor Spin w/ MCAT Tool

- Tool guiding the user step by step to tune the control parameters of their MC application
- Run-time tuning of control parameters
- Generation of header file w/ resulting parameters
- NXP MCU independent

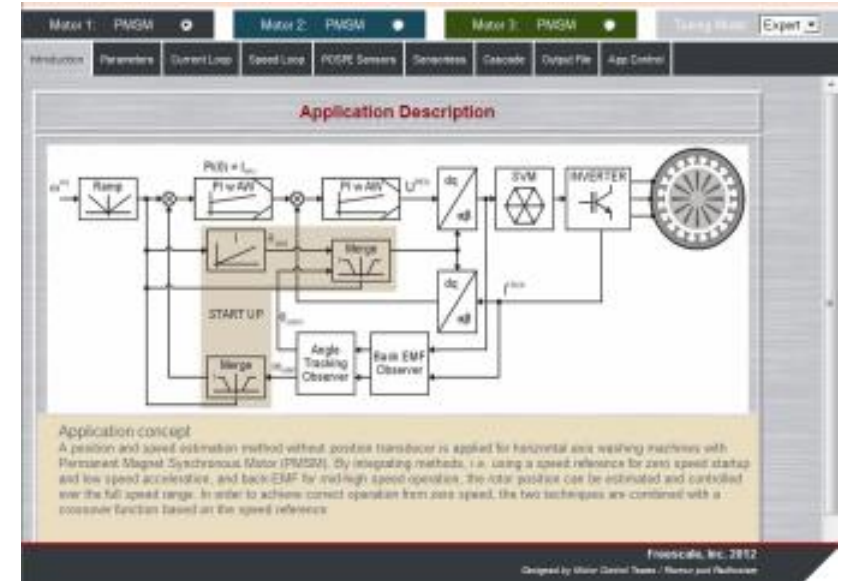
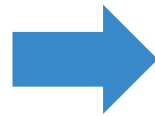

www.nxp.com/MCAT



Model Based Design Steps

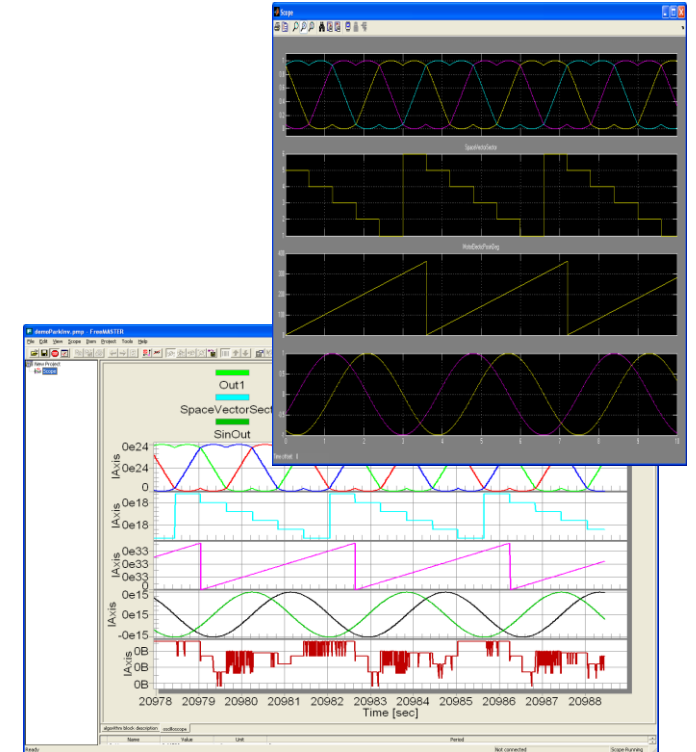
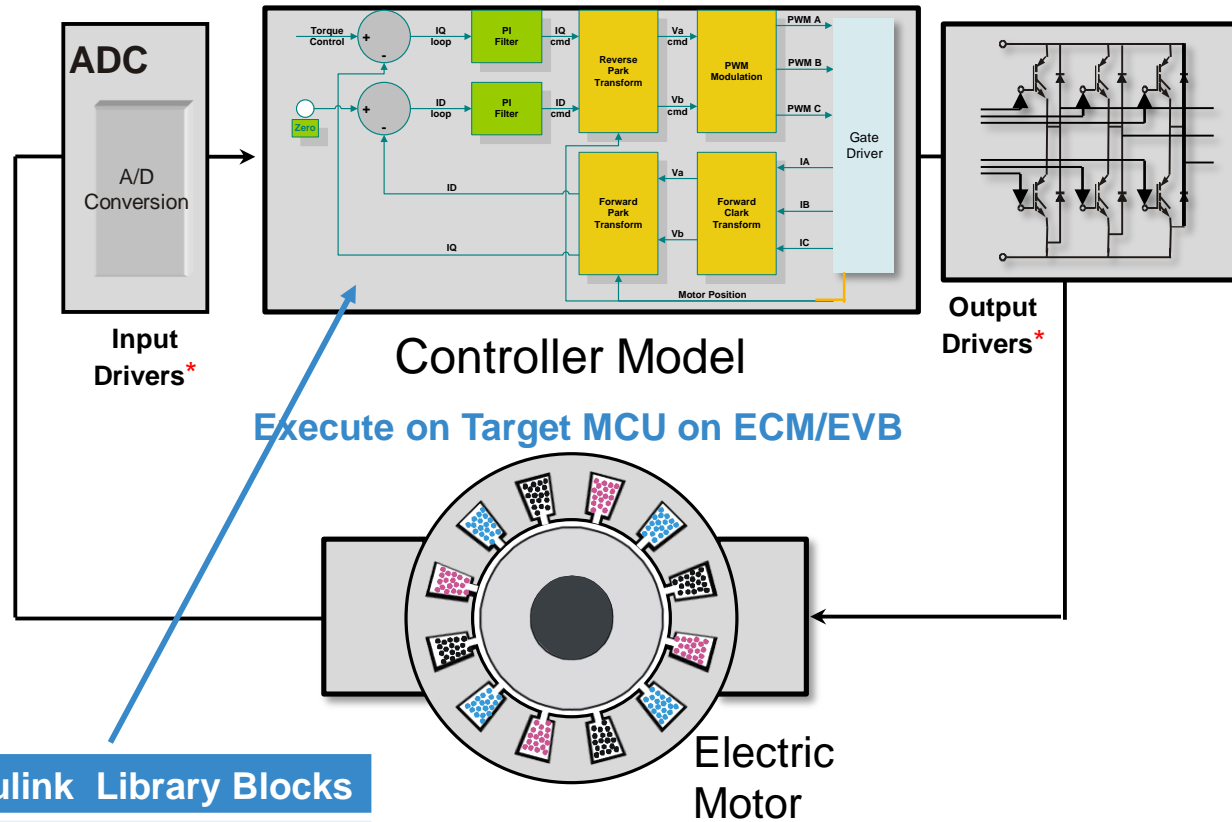

S12ZVM Simulink Library Blocks

- Peripherals: PMF, Timer, ADC, PTU, etc.
- Math & Motor Control Library blocks: Clark, Park, PI, Mul, Atan, ..etc.

Step 1: Simulation in PC environment

Step 2: (SIL) Generated code executes as atomic unit on PC

Step 3: (PIL) Executes generated code on the target MCU

Step 4: Execute on Target MCU on ECM/EVB

S12 MagniV Benefits

S12 MagniV solutions deliver optimal system cost and physical footprint for sensor and actuator applications.

- Reduced PCB Space
 - Up to 30%
- Improved manufacturing efficiency
 - Replacing typically 3 IC by 1 MagniV reduces assembly and test cost while quality improves
- Reduced Bill Of Material (BOM)
 - Fewer components to purchase, handle, store and qualify
- Simplified motor control that speeds up time-to-market
 - Save up to 6 months on development, validation and ISO26262 implementation
 - Abstract the complexity of 3-phase motor control software development
 - Production-ready Automotive quality SW and Tools
 - SafeAssure program

S12ZVM Family Feature Set Summary

Connectivity	CAN	LIN	CAN	LIN	CAN	LIN			PWM			
Product Name	VMC256	VML128	VMC128	VML64	VMC64	VML32	VML31	VML31	VM32		VM16	
Package	80LQFP-EP	64LQFP-EP	64LQFP-EP	64LQFP-EP	64LQFP-EP	64LQFP-EP	64LQFP-EP	48LQFP-EP	64LQFP-EP	48LQFP-EP	64LQFP-EP	48LQFP-EP
EEPROM (bytes)	1K	512	512	512	512	512	128	128	128	128	128	128
PHY	CAN	LIN	0	LIN	0	LIN	LIN	LIN	HV	HV	HV	HV
Separate VREG	1+1	0	1	0	1	0	0	0	0	0	0	0
GDU (HS / LS)	3/3	3/3	3/3	3/3	3/3	3/3	3/3	3/3	3/3	3/3	3/3	3/3
Bootstrap Diodes	0	0	0	0	0	0	3	3	3	3	3	3
Op Amp	2	2	2	2	2	2	2	1	2	1	2	1
ADC (ext. channels)	8 + 8	4 + 5	4 + 5	4 + 5	4 + 5	4 + 5	4 + 5	1 + 3	4 + 5	1 + 3	4 + 5	1 + 3
MSCAN	1	1	1	1	1	1	0	0	0	0	0	0
SCI	2	2	2	2	2	2	2	1	2	1	2	1
SPI	1	1	1	1	1	1	1	0	1	0	1	0
TIM (IC/OC channels)	4	4	4	4	4	4	4	3	4	3	4	3
PWM channels	6+4	6	6	6	6	6	6	6	6	6	6	6
Internal timers	RTI+API	RTI+API	RTI+API	RTI+API	RTI+API	RTI+API	RTI+API	RTI+API	RTI+API	RTI+API	RTI+API	RTI+API
External FET Nominal Total Gate Charge (nC)	100-150	100-150	100-150	100-150	100-150	100-150	50-80	50-80	50-80	50-80	50-80	50-80
Package Size	12mm x 12mm	10mm x 10mm	10mm x 10mm	10mm x 10mm	10mm x 10mm	10mm x 10mm	10mm x 10mm	7mm x 7mm	10mm x 10mm	7mm x 7mm	10mm x 10mm	7mm x 7mm
Samples	Now	Now	Now	Now	Now	Now	Now	Q2 2015	Now	Q2 2015	Now	Q2 2015
Production release	H2 2016	Q1 2014	Q1 2014	Q1 2014	Q1 2014	Q1 2014	Q1 2016	Q3 2016	Q1 2016	Q3 2016	Q1 2016	Q3 2016



S12ZVL Family

Integrated General Purpose LIN Node

Key Features:

- S12Z core (32MHz)
- 12V VREG (device + ext comp)
 - 70mA total (170mA with ext. Ballast)
- LIN-PHY, LIN2.x / J2602 compliant
- On chip RC Oscillator (trimmed to +/- 1.3% over full temp range)
 - No need for ext Xtal on LIN
- High Voltage Input (HVI)
 - internal tied ADC for 12V analog measurements
- Evdd 5V/20mA (switchable output overcurrent protected)
- List-based 10-Bit ADC (LADC)
- Optional S12ZVLA : enhanced analog
 - 12-Bit LADC, PGA, Analog Comparator, and DAC
- 1-3x N-GPIO (25 mA sink capability)
- Small 32QFN 5x5mm footprint option
- ISO26262 support (FMEDA, safety guide)

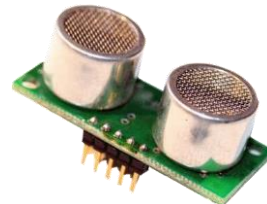
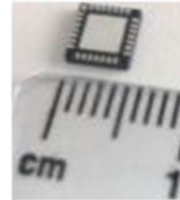

LIN-PHY			Pierce Osc.		Temp Sense	10/12-Bit LADC	
G P I O	MS CAN	2x SCI	RCosc. +/-1.3%	PLL	1ch ACMP	◀ + - ▶	
	SPI	IIC	S12Z 32MHz Bus		8-bit DAC + OpAmp	▶ + - ▶	
	BDM BDC	KWU	Win Wdog	8-128KB Flash (ECC)		PGA (20/40/80x)	
	TIM 16b 8+4ch			128-1KB EEPROM (ECC)	1-8kB RAM (ECC)	Vreg	Vsup sense
	PWM up to 8ch/16Bit						70, or up to 170mA with ext. Ballast
	1# EVDD	1-3# NGPIO	1 HV Input				

Digital Components	5V Analogue Components
MCU Core and Memories	High-Voltage Components

Family Options:

- Flexible Memory Options: 8kB to 128kB Flash version
- Optional Analog Enhancement (S12ZVLA64/96/128) with 12 Bit ADC, ACMP, DAC & PGA
- 32-LQFP , 48-LQFP or 32QFN Packaging
- C / V / M Temperature options (up to 125°C Ta)

Target Applications:

- Space-constrained LIN slave nodes
- Sensors / actuators
- Switch panel / user interface
- Interior RGB LED lighting
- Ultrasonic sensors

Target Applications

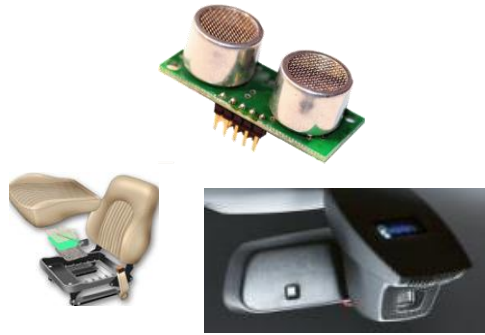

LIN Sensors

Product Function

- Connect sensors to LIN-Network (with signal pre-conditioning)

Market Requirements

- LIN-PHY, 12V-Vreg, MCU
- Small formfactor (QFN)
- ADC, SPI



LIN Switch Panels

Product Function

- Read multiple switch-positions and feed into LIN-network

Market Requirements

- LIN-PHY, 12V-Vreg, MCU
- Multiple GPIOs
- ADC



LIN Actuator

Product Function

- Convert LIN-command into an activity (eg driving LEDs)

Market Requirements

- LIN-PHY, 12V-Vreg, MCU
- Drivers (3x25mA drive strength in case of RGB-LED)
- ADC

S12ZVL for Switch Panel Applications

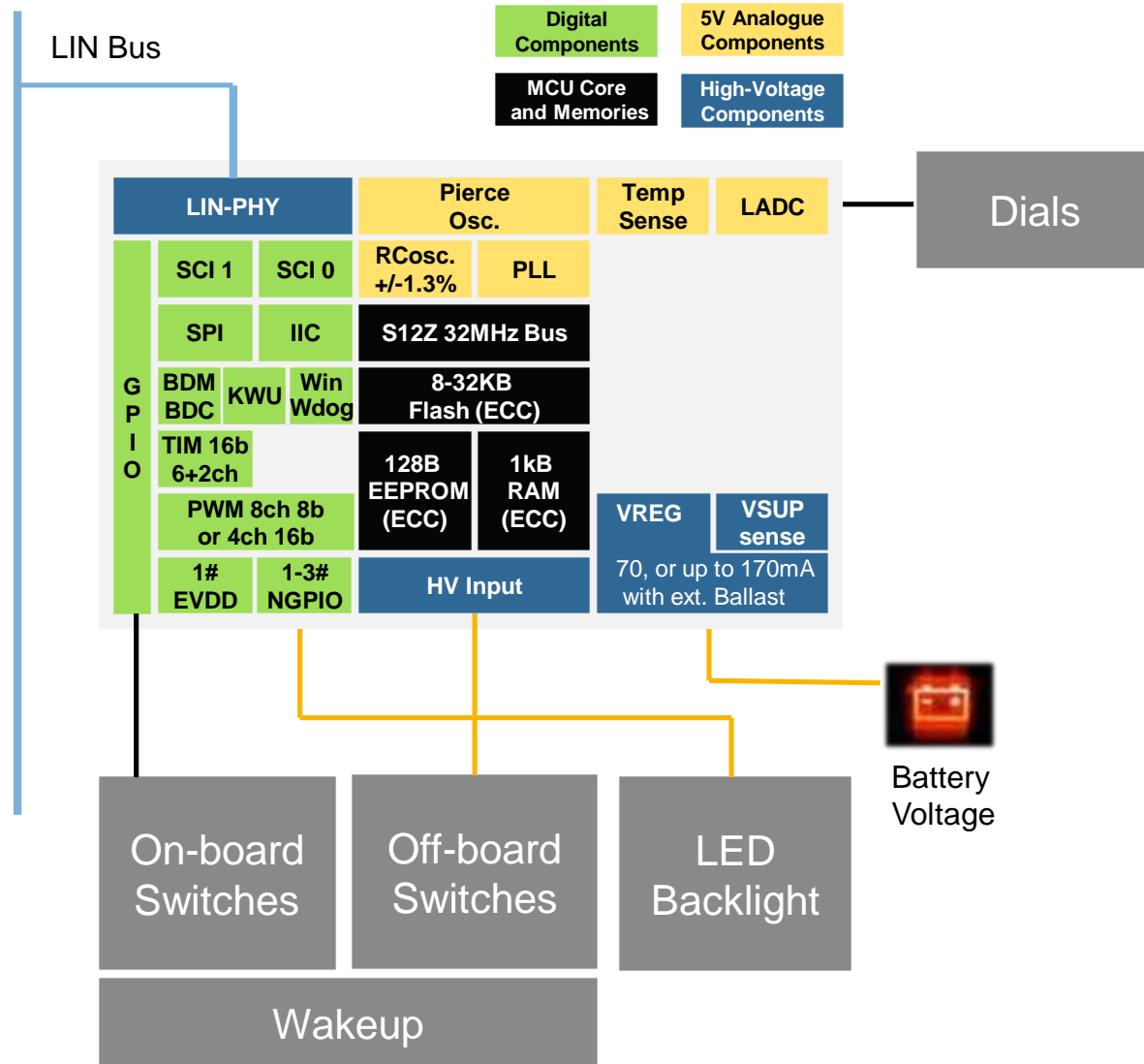

S12ZVL for Sensor Applications

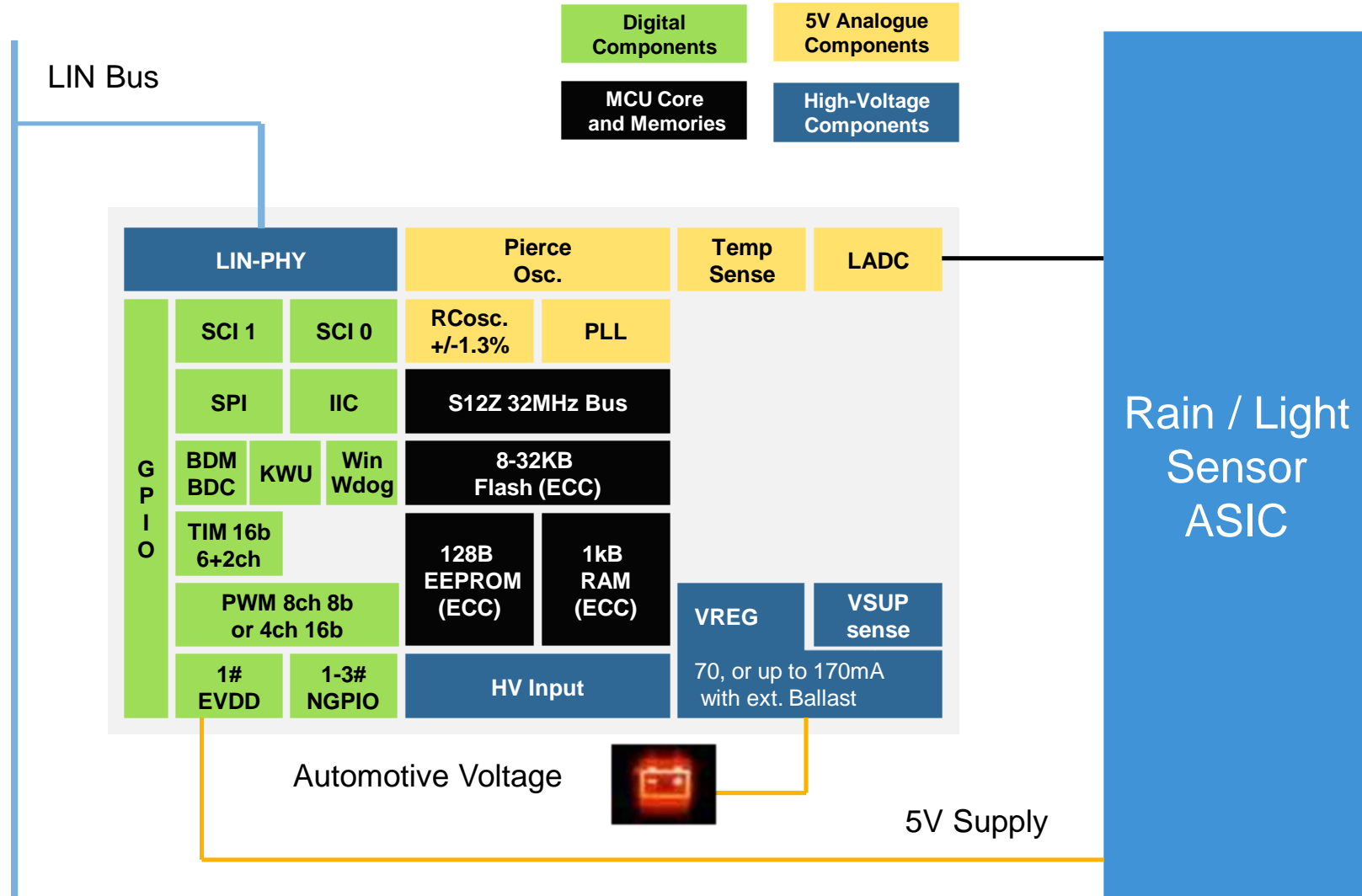

http://www.bmw.com/com/en/insights/technology/technology_guide/articles/rain_sensor.html



S12ZVL128 in Occupant Detection System

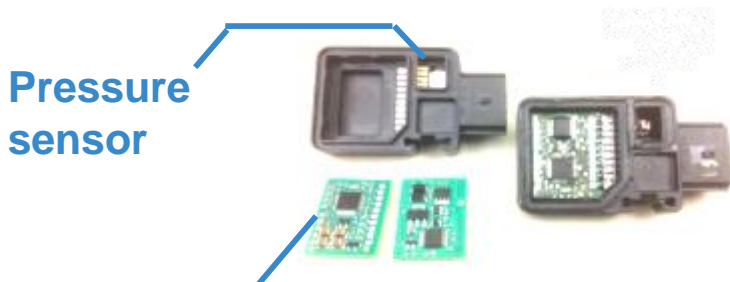
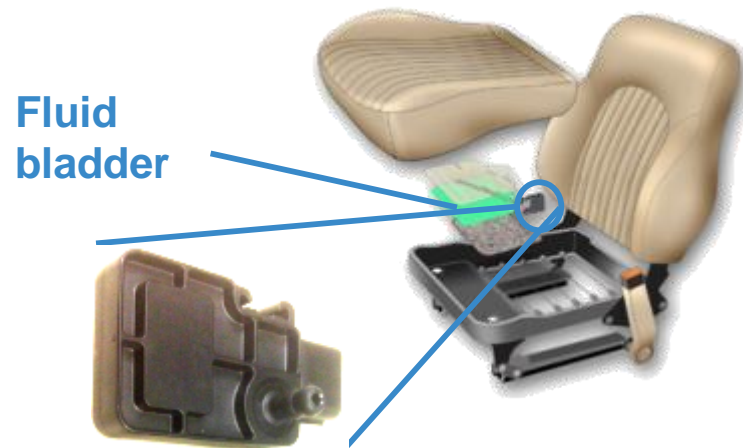

MCU doing signal-preprocessing & LIN (CAN) communication

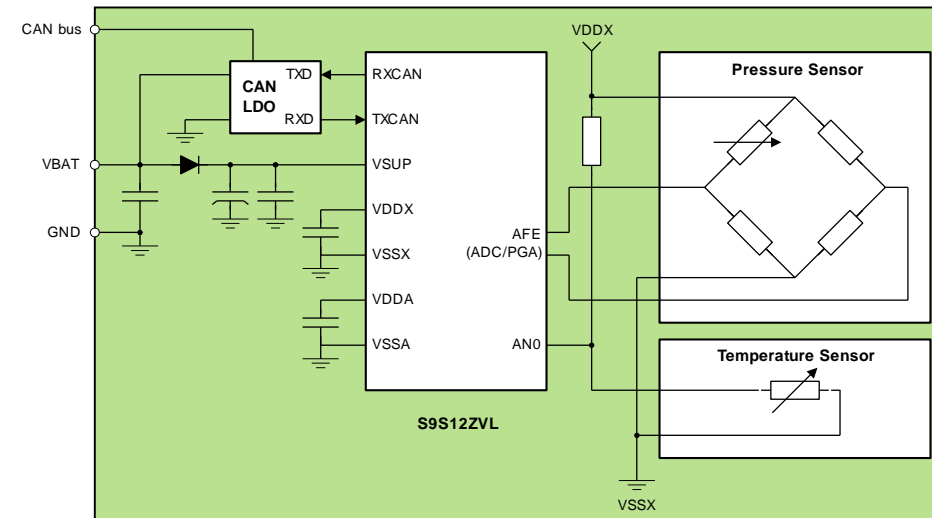
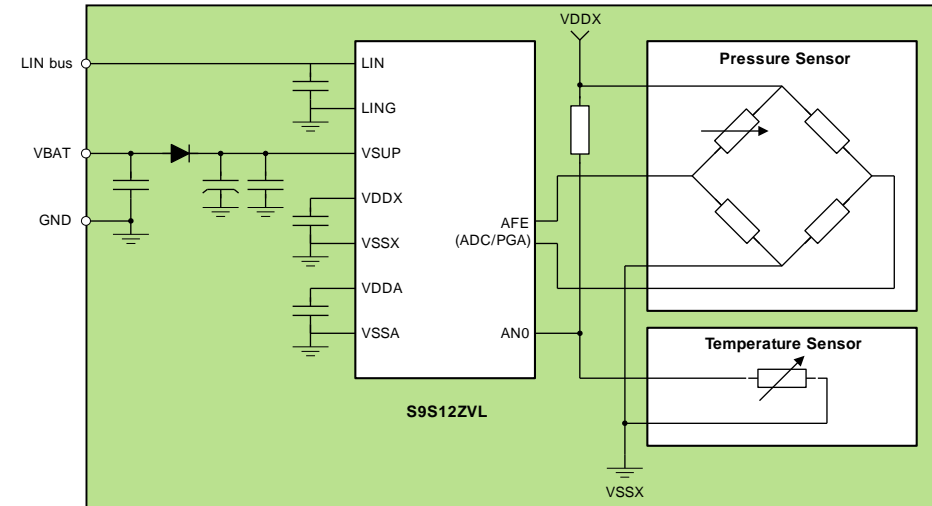

S12ZVL64/96/128 (VL128) – Key Features

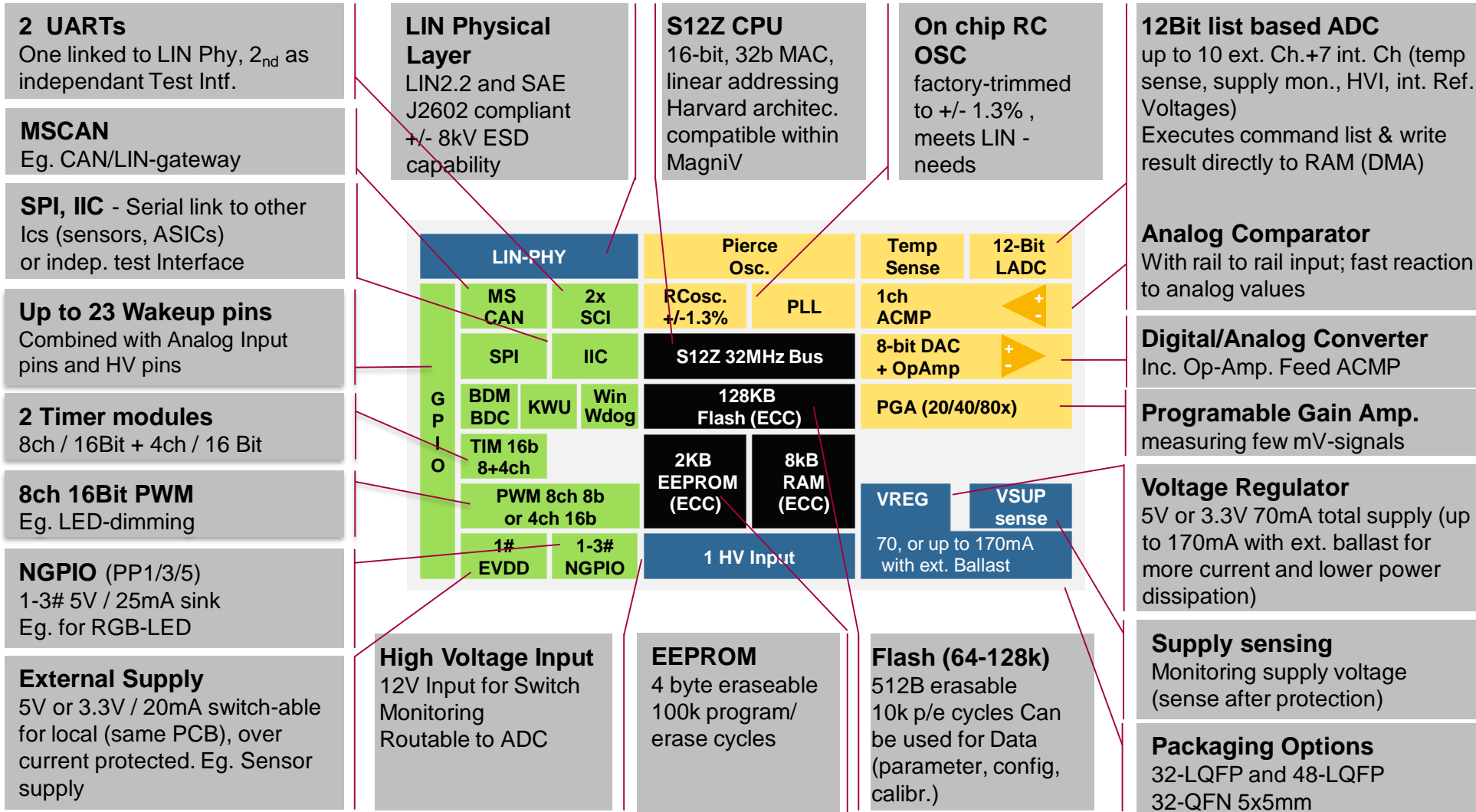

S12 MagniV S12ZVL Smallest Integrated LIN Slave MCU

- System in a Package - Highly integrated part which is ideal for space constrained applications such as Actuators, Sensors, LIN nodes etc.
- Low System Cost – Direct connection with Battery, integrated LIN Phy, EVDD and NGPIOs reduce system, qualification and manufacturing cost.
- High Reliability – High immunity to EMI and ESD stresses, LIN 2.x compliant with +/- 8kV ESD capability.
- Enablement – Supported by comprehensive hardware and software system (free low-level drivers to enterprise 3rd party tools) which reduces development costs and time to market.

S12ZVL Specifications

Flash EEPROM	8 – 128 KB 2 KB	Timer/PWM	8ch. + 4ch. 16bit/ 8ch 16bit
RAM	8 Kb	12V VREG	12V/70mA, 170mA w ext ballast
Core	S12Z	EVDD	1ch 5V/20mA (source)
Speed	32 MHz	NGPIO	3ch 5V/25mA (sink)
ADC	10ch 12bit	SCI/SPI/IIC	2/1/1
HVI	1	Packages	32LQFP, 32QFN, 48LQFP
LIN Phy	1	Op Range	5.5V – 18V

	32LQFP	32QFN-EP	48LQFP
	S9S12ZVL32F0MLC	S9S12ZVLS3F0MFM	S9S12ZVL32F0MLF
	S9S12ZVL16F0MLC	S9S12ZVLS1F0MFM	S9S12ZVL16F0MLF
	S9S12ZVL8F0MLC	S9S12ZVLS8F0MFM	S9S12ZVL8F0MLF
	S9S12ZVLA12AF0MLC	S9S12ZVLA12AF0MFM	S9S12ZVLA12AF0MLF

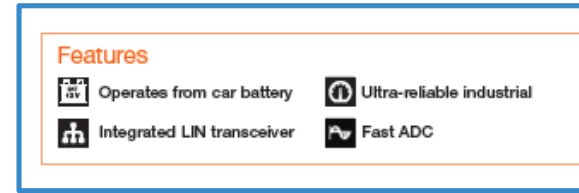

Block Diagram

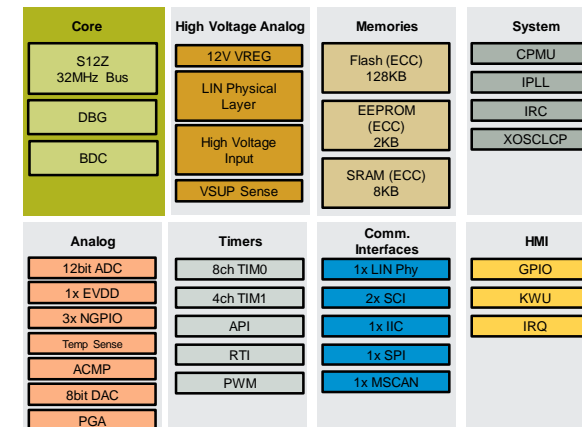

Main Application Diagram

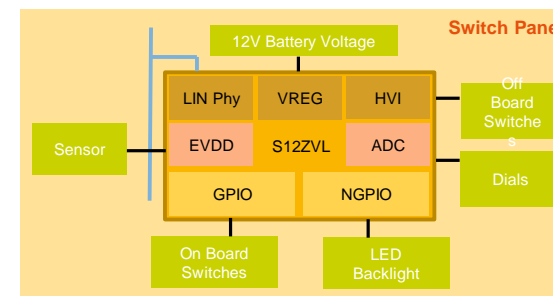

For more information, visit www.NXP.com/PARTNUMBER

Success Stories

- Lin-based User-Interface in Europe and Asia
- Lin-based Immobilizer receiver in US
- Lin-based Mirror control in Europe
- Lin-based Airquality sensor in Europe

Target Applications

- LIN nodes
- LIN switch panel / user interface
- LIN actuators, sensors
- HVAC
- Lighting controls
- Ambient lighting
- Seat positioning
- Ultrasonic Sensors

Enablement Tools

- Evaluation Boards / Hardware
 - TRK-S12ZVL
 - TRK-S12ZVL128
 - DEVKIT-ZVL128
- Reference Solutions
 - Ultrasonic distance measurement
 - LIN RGB LED
- CodeWarrior, Cosmic
- LIN drivers



S12ZVC Family

Integrated Small CAN Nodes

Key Features:

- S12Z core (32MHz)
- On chip CAN PHY:
 - CAN-supply requires ext. Ballast Transistor
 - Dominant Txd timeout
 - OEM emission limits achieved WITHOUT Choke (up to 500kbps)
- 12V VREG (device + ext comp)
 - 70mA total, 170mA with ext. Ballast
 - High Voltage Input (HVI)
 - internal tied ADC for 12V analog measurements
- Specific features for sensor type applications:
 - list-based 12-Bit ADC (LADC)
 - 16ns resolution Timer / PWM
 - 2x Analog Comparator with 8Bit DAC
 - SENT
 - ISO26262 support (FMEDA, safety guide)
- Target Applications:
 - Any automotive CAN-node (non-Autosar)
 - Powertrain sensors & actuators
 - CAN-based user-interfaces

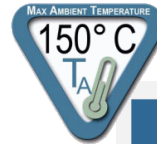

CAN-PHY				Pierce Osc.		Temp Sense	12-Bit LADC
G P I O	2 x SCI	MSCAN		RCosc. +/-1.3%	PLL	2ch ACMP	◀ + - ▶
	2x SPI	IIC	Sent tx	S12Z 32MHz Bus		8-bit DAC + OpAmp	▶ + - ▶
	BDM BDC	KWU	Win Wdog	64-192kB Flash (ECC)			
	HR-PWM 4ch16b	PWM 4ch16b		1-2kB EEPROM (ECC)	4-12kB RAM (ECC)	VREG for CAN PHY with ext. ballast	
	HR-Tim 4ch16b	Tim 8ch16b				VREG	VSUP sense
	1# EVDD	4# NGPIO		2 HV Input		70, or up to 170mA with ext. Ballast	

Digital Components	5V Analogue Components
MCU Core and Memories	High-Voltage Components

Family Options:

- Flexible Memory Options: 64kB to 128kB Flash version
- 48-LQFP or 64-LQFP-EP Packaging
- C / V / M / W Temperature options (**up to 150°C Ta**)
- Fully featured (S12ZVCx) or reduced featureset (S12ZVCx)



S12ZVC for Seatbelt Pretensioner

S12ZVC Benefits:

- CAN-based (LIN too slow)
- Limited PCB-space
- ASIL-requirements

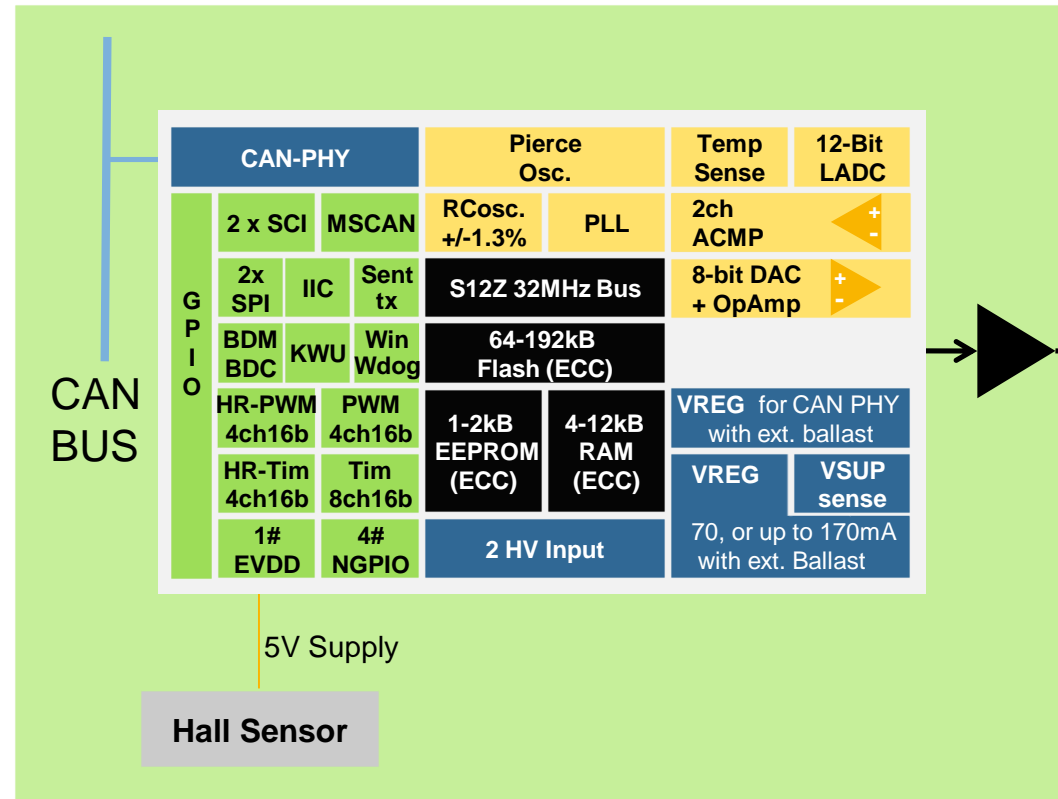

S12ZVC for Powertrain Sensors

S12ZVC Benefits:

- Limited PCB-space
- ASIL-requirements
- High resolution timers and DMA enabled LADC
- On-chip analog comparator and DAC
- EVDD 5V switchable sensor supply

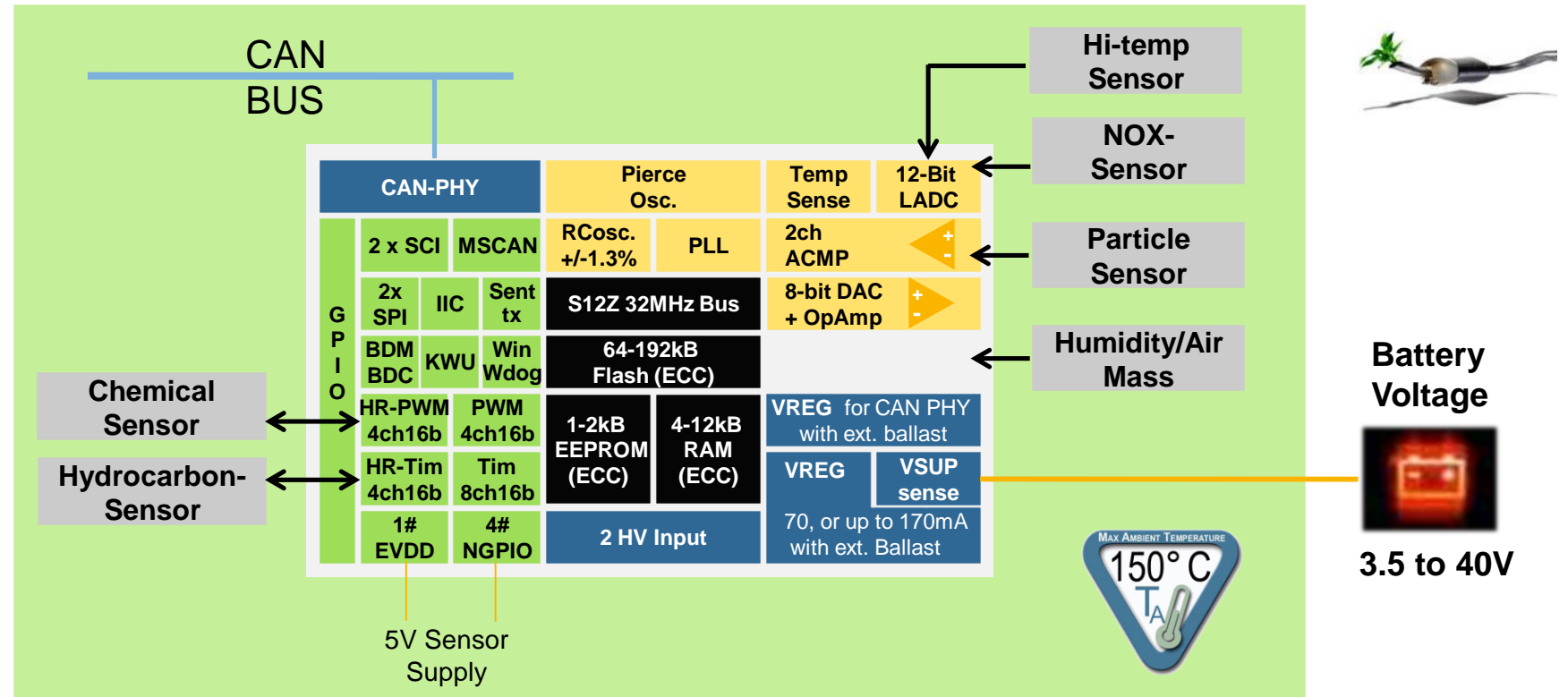

S12ZVCA (Hearst-fully Featured) – Key Features

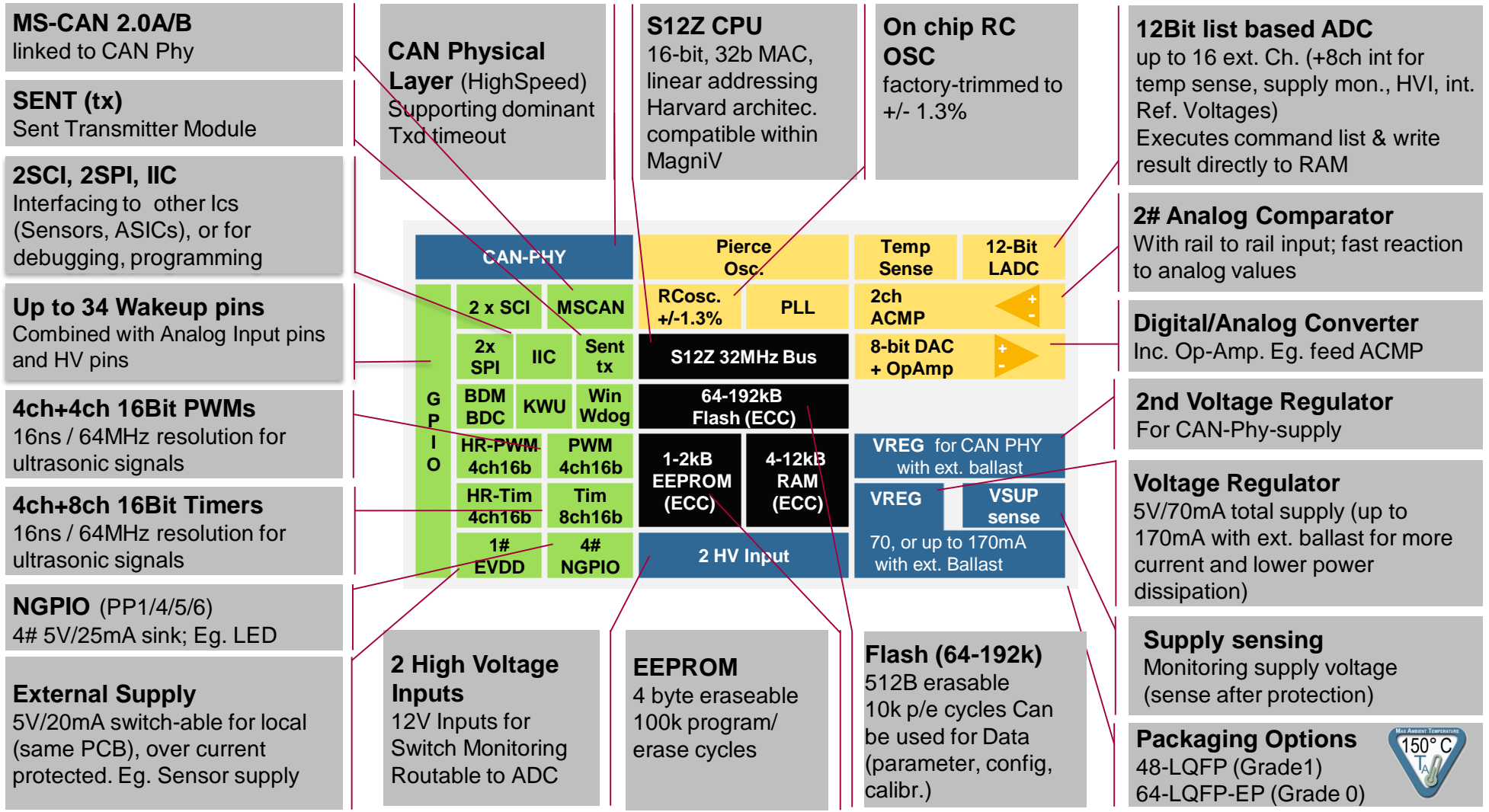

Digital Components	5V Analogue Components
MCU Core and Memories	High-Voltage Components



MagniV: Product Families

MagniV offers a broad portfolio of solutions for motor control or interface nodes

Motor Control focus

Sensor Interface focus

S12VR Relay driven motors



- Window lift
- Sunroof
- Power doors

S12ZVM BLDC/DC motors

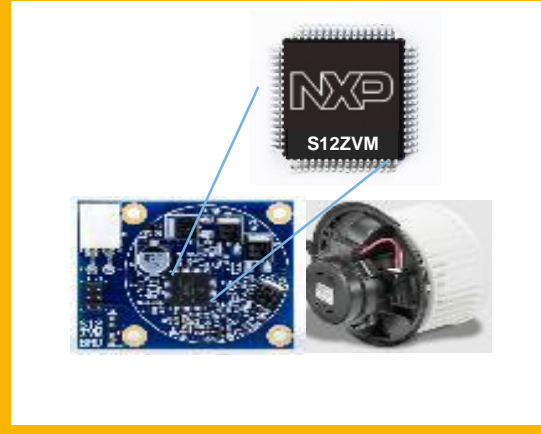

- Fuel pump
- Oil pump
- Fans
- Wipers

S12ZVC CAN nodes

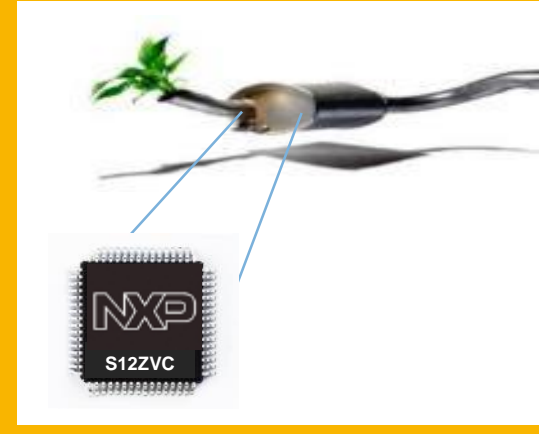

- Safety sensors
- Emission sensors
- Gear shift

S12ZVL LIN Nodes



- Steering wheel switches
- Door modules
- Sensors

✓ Reduced PCB Space

✓ Reduced Bill of Material

✓ Improved manufacturing efficiency and quality

✓ Simplified development



SECURE CONNECTIONS
FOR A SMARTER WORLD