

# 上高县朋祥兴科技有限公司

## 确 认 书

### SPECIFICATION FOR APPROVAL

客户名称

CUSTOMER : \_\_\_\_\_

产品说明

DESCRIPTION :         PXX 扁平线共模电感        

产品型号

PRODUCT MODEL :         PXT100951        

产品编号

PART NUMBER : \_\_\_\_\_

客户料号

CUS. P/N : \_\_\_\_\_

送样日期

DATE : \_\_\_\_\_

PLEASE RETURN ON COPY AFTER APPROVALED (请确认后回传)

APPROVALED BY CUSTOMER (客户承认栏)

APPROVALED BY CUSTOMER (客户承认栏)		

拟制 PREPARED BY	审核 CHECKED BY	批准 APPROVED BY
孙学林	钟青	杨舟华

地址：江西省宜春市上高县工业园沙基路朋祥兴科技园

产品型号 MODEL	PXX1515-15mH min	客户简称 CUSTOMER		版本 REVISION	1.0
产品说明 DESCRIPTION	PXX 扁平线共模电感	客户料号 CUS.P/N		日期 DATE	2020/3/15

**规格变更履历表 SPECIFICATION CHANGE SCHEDULE**

版本 REVISION	变更理由及内容 REASONS AND CONTENTS	发行日期 DATE	发行部门 DEPARTMENT
1.0	新订	2020/10/20	工程部

拟制 PRERARED BY	审核 CHECKED BY	批准 APPROVED BY	页码 PAGE
孙学林	钟青	杨舟华	第 1 页 共 5 页

产品型号 MODEL	PXX1515-15mH min	客户简称 CUSTOMER		版本 REVISION	1.0
产品说明 DESCRIPTION	PXX 扁平线共模电感	客户料号 CUS.P/N		日期 DATE	2021/3/15

1. 机械尺寸 PHYSICAL DIMENSION: mm

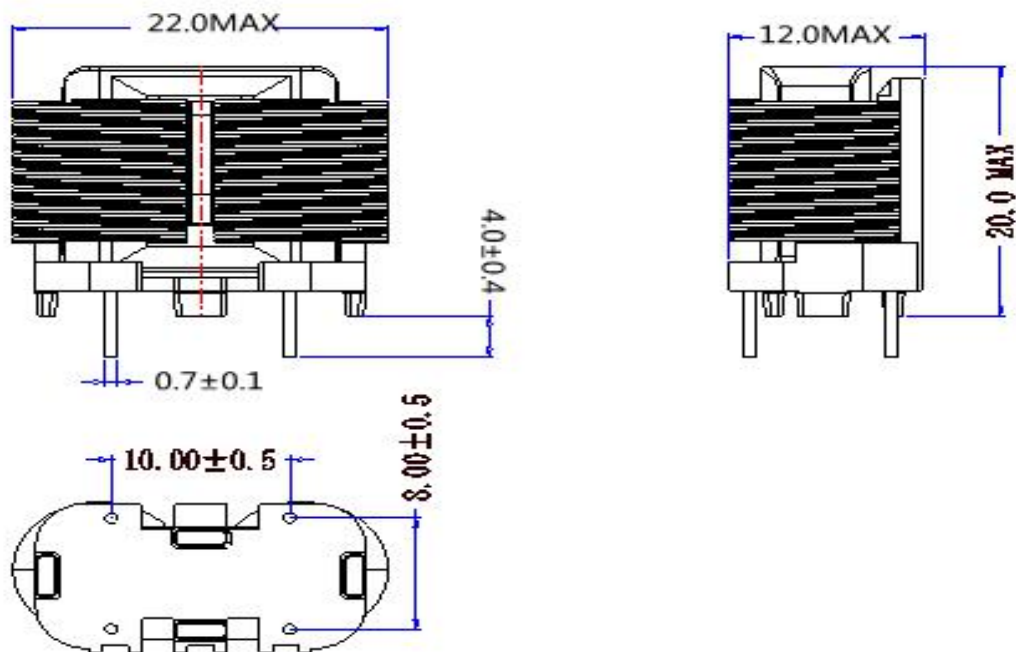

2. 电气原理图 SCHEMATIC:

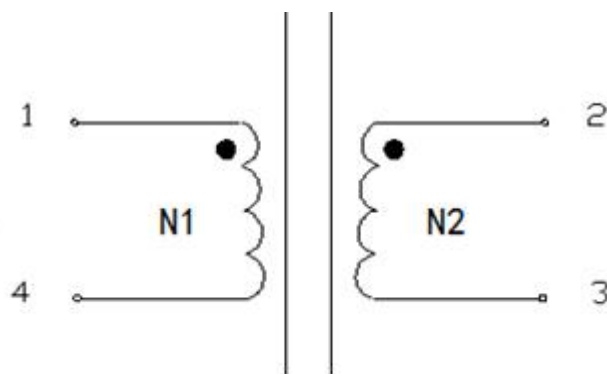

拟制 PRERARED BY	审核 CHECKED BY	批准 APPROVED BY	页码 PAGE
孙学林	钟青	杨舟华	第 2 页 共 5 页

产品型号 MODEL	PXX1515-15mH min	客户简称 CUSTOMER		版本 REVISION	1.0
产品说明 DESCRIPTION	PXX 扁平线共模电感	客户料号 CUS.P/N		日期 DATE	2021/3/15

### 3. 绕线步骤 WINDING STEP INFORMATIONS:

绕组 WINDING	脚位 TERMINAL		圈数 TURNS	漆包线 MAGNETIC WIRE	胶带 TAPE	备注 DESCRIPTION
	起始	结尾				
N1	1	4	50TS REF	0.15*1.5mm 扁平线		密绕
N2	2	3	50TS REF	0.15*1.5mm 扁平线		密绕

### 4. 绕制工艺要求/MANUFACTURE SPECIFICATION

- 底座 (2+2), 磁芯为PXX1515磁芯;
- N1同时绕制N2;
- 产品需浸油, 无铅制程;
- 电气特性 ELECTRICAL CHARACTERISTICS:@25±5℃

序号 NO.	名称 ITEMS	测量端 MEASURED POINT	测量值 TECHNICAL DATA	测试条件 TESTING CONDITION	测试仪器 APPARATUS
1	电感量 INDUCTANCE	L <sub>1-4</sub> =L <sub>2-3</sub>	15mH min	1KHz,0.25V 25℃	翰科 3250
2	直流电阻 DC Resistance	DCR <sub>1-4</sub> =DCR <sub>2-3</sub>	180mΩ MAX	1KHz,0.25V SER Short Other Pin	
3	抗电强度 HI-POT TEST	N1对N2 COIL 1 TO COIL 2	无击穿	2.0KVAc 5mA 3SEC	蓝光 LK2670A
		N1对磁芯 PRIMARY - CORE		2.0KVAc 5mA 3SEC	
4	匝比 TURNS RATIO	N1:N2	50 (REF) :50	1KHz,0.25V	翰科 3250

拟制 PRERARED BY	审核 CHECKED BY	批准 APPROVED BY	页码 PAGE
孙学林	钟青	杨舟华	第 3 页 共 5 页

产品型号 MODEL	PXX1515-15mH min	客户简称 CUSTOMER		版本 REVISION	1.0
产品说明 DESCRIPTION	PXX 扁平线共模电感	客户料号 CUS.P/N		日期 DATE	2021/3/15

## 5. 材料清单 MATERIAL LIST:

ITEM	名称	规格	MANUFACTURER	UL FILE NO.
1	磁芯	PXX1515	ShanDongHengRui Magent technology co.,ltd (山东恒瑞磁电)	0/N
			Tengzhou Mingji Nagnctism Indus try co.Itd (滕州铭基磁业)	0/N
2	扁平漆包线	0.15*1.5 1UEW	Jiangsu Telison New Materials Co ;Lt (江苏泰利松)	E499370
3	锡	SN99.7	SHENZHEN XIN JIN CHUN TIN PRODUCTS CO. , LTD (兴鸿泰锡业)	SGS:SZXEC 20024130008
4	凡立水	RT9669	NOBLE FLOWER ELECTRONIC TECHNOLOGY CO; LTD	OB0R2. E213437
5	底座 (2+2)	T375HF	台湾长春电木	T378JB

## 6. 包装模式:吸塑盒+纸箱包装

1. 每层数量: 56PCS
2. 每箱层数: 13 cases
3. 每箱数量: 728PCS
4. 单个重量:11.0g (REF)
5. 每箱重量:8.5KG ( REF)

拟制 PRERARED BY	审核 CHECKED BY	批准 APPROVED BY	页码 PAGE
孙学林	钟青	杨舟华	第 4 页 共 5 页

# 测试报告

MEAS. ITEM		L(1-4) mH	L(2-3) mH	DCR(1-4) mΩ	DCR(2-3) mΩ	Lk1-4 短路 L(2-3)	
SPEC.	YOUR						
	SUGGEST	15 min	15min	180MAX	180MAX	漏感	
TEST	FREQ	1KHz/0.25V	1KHz/0.25V	内阻 100Ω	内阻 100Ω	1KHZ/0.25V	
1		32.8	32.8	107	107	95.4uH	
2		30.9	30.9	108	108	93.5uH	
3		30.8	30.8	107	107	95.0uH	
4		26.8	26.8	108	108	95.4uH	
5		27.9	27.9	108	108	95.0uH	
6		29.1	29.1	107	107	95.4uH	
YOUR SAMPLE							
TEST CONDITION:                      TEMP.:    25°C (REF.)                      R.H.:    60% (REF.)							
REMARK:   HI-POT TEST OK							