

Left Angled PCB Terminals

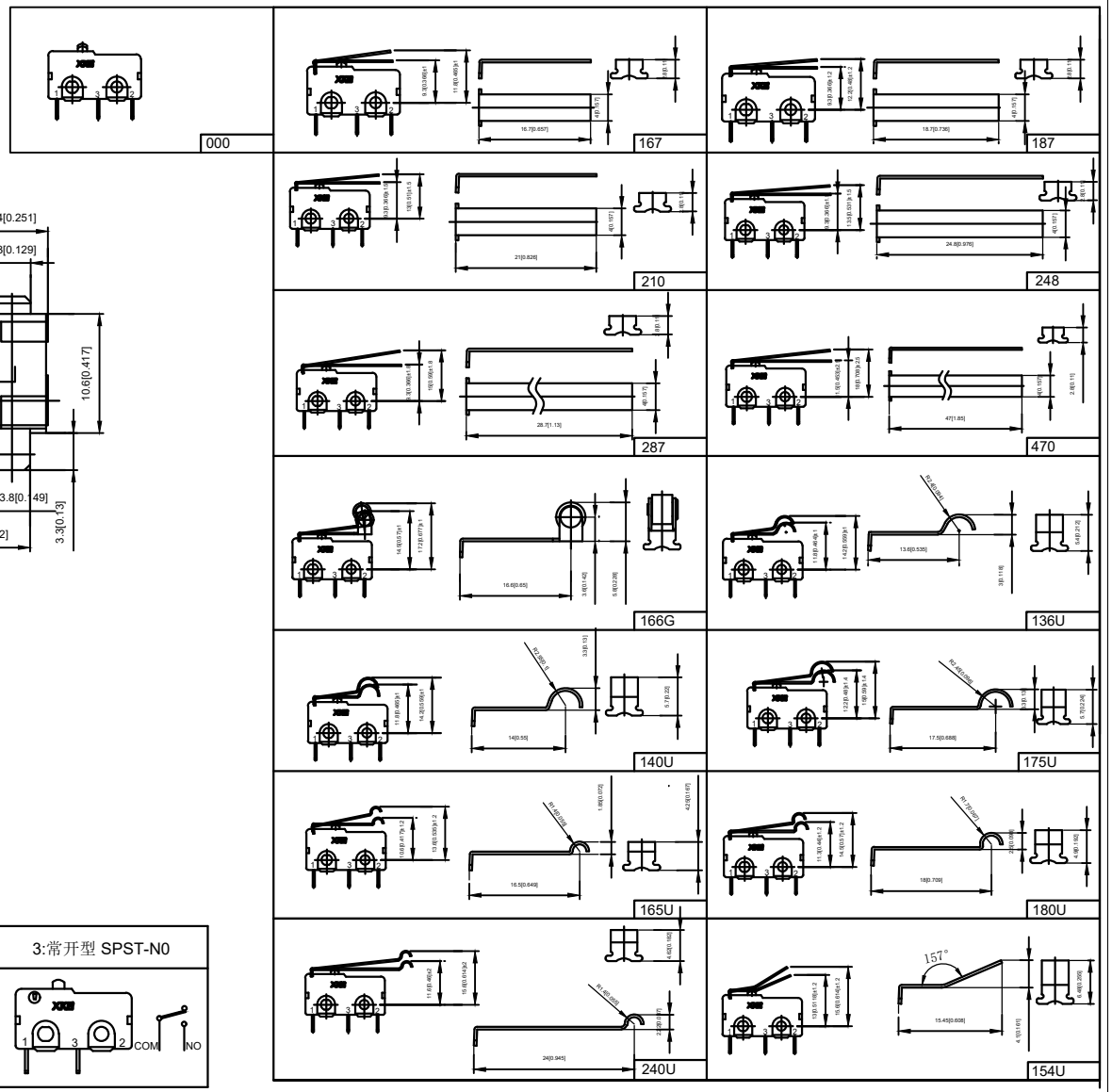
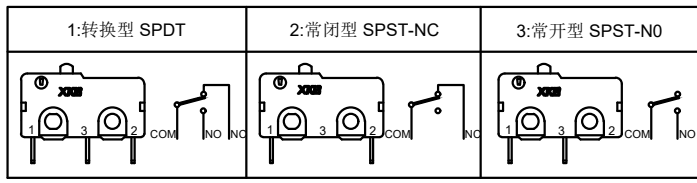
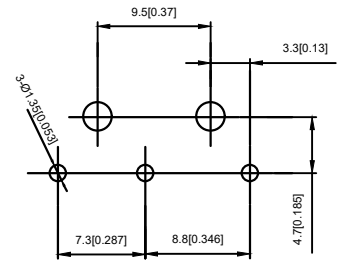
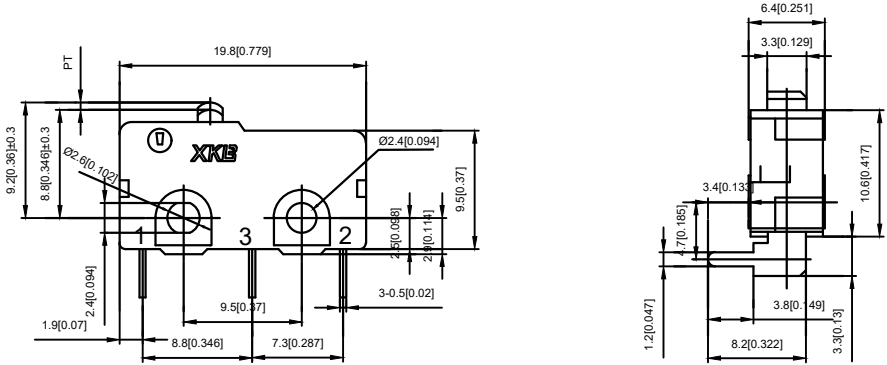

DSND	DATE	SCALE: N/A	MODEL TYPE: The micro switch
DWN	DATE	VIEW:	PART NO.:
CHKD	DATE	UNIT: mm/in	DWG NO.: SM5-XXXD-X
APPD	DATE	SIZE: A4	WEIGHT: 1.0g
UNSPECIFIED TOLERANCES			SHEET: 1/1
www.xk-dg.cn www.helloxkb.com www.helloxkb.cn			REVISION: A0

ΔX					units: mm
ΔX					tolerance: X.X ±0.2mm
ΔX					X.XX ±0.1mm
MARK	DESCRIPTION	DATE	REVISED	APPROVED	X.XXX ±0.05mm