

THIS DRAWING IS UNPUBLISHED. RELEASED FOR PUBLICATION 20
 © COPYRIGHT 20 BY - ALL RIGHTS RESERVED.

LOC	DIST	REVISIONS					
		P	LTR	DESCRIPTION	DATE	DWN	APVD
A1	-	C		FIRST ISSUE	01AUG2012	A.B.	M.G.
		C1		REVISED PER ECO-17-006730	10MAY2017	M.G.	M.G.

CODING TABLE / PART NUMBER - FRONTAL VIEW

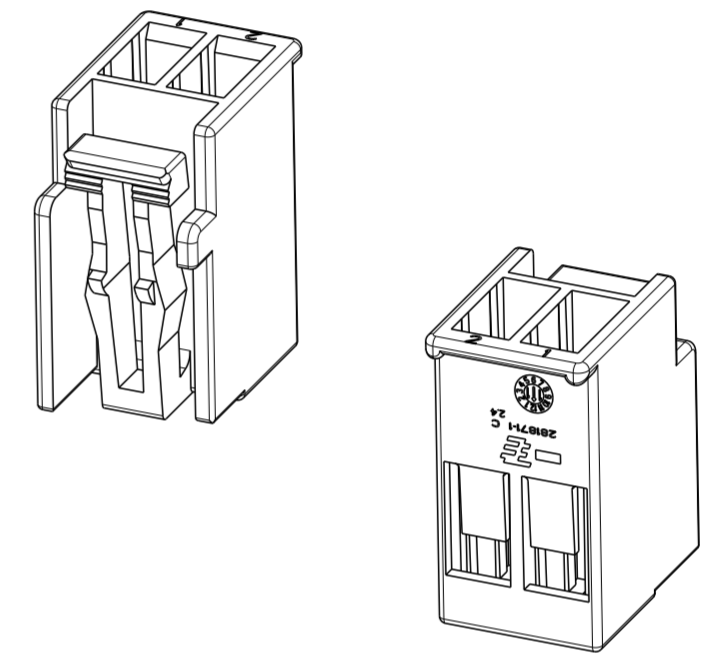
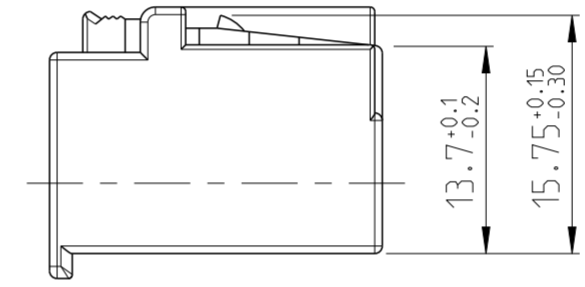
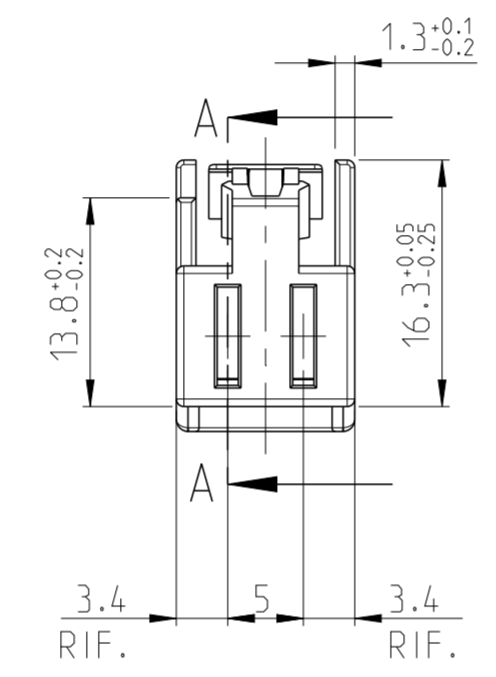
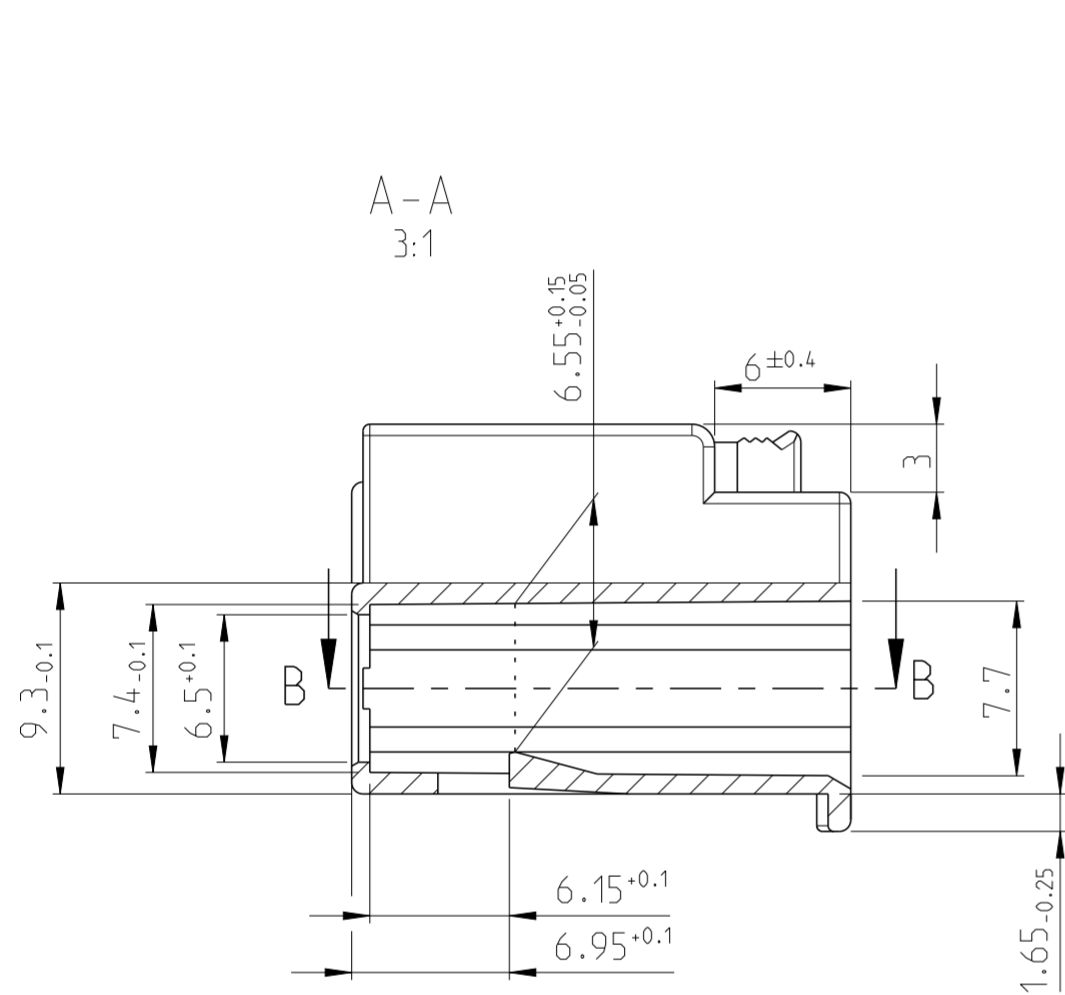
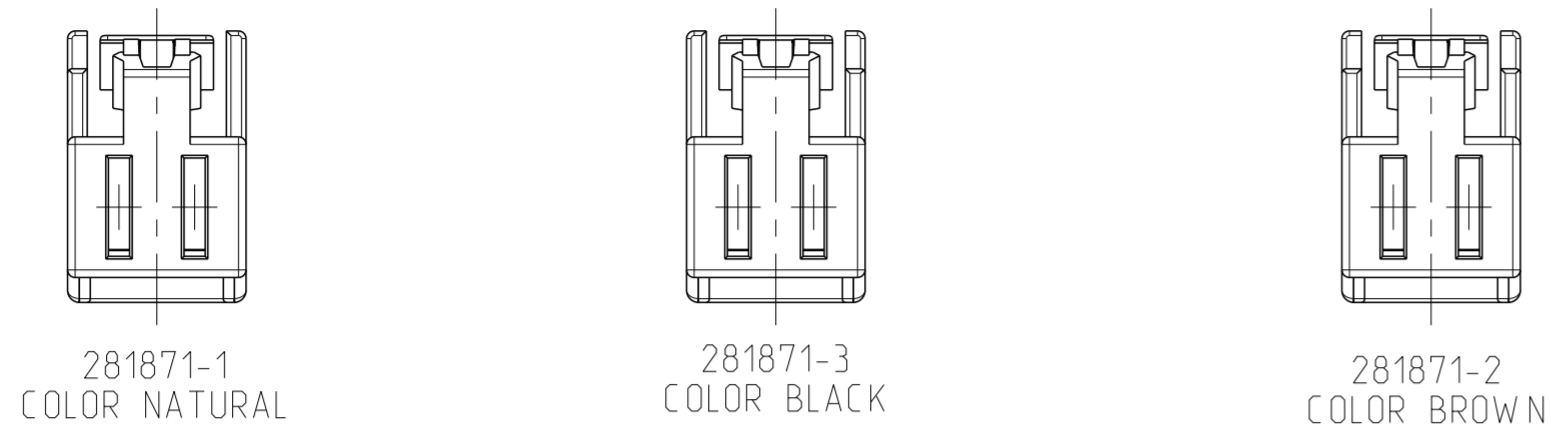

P/N 281871-1 AS SHOWN

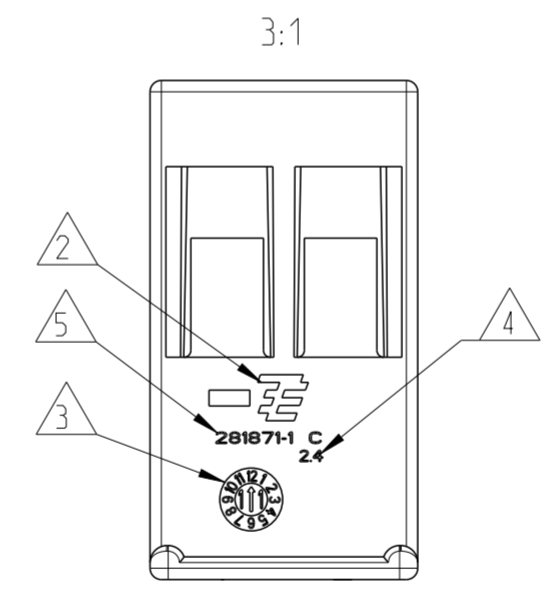
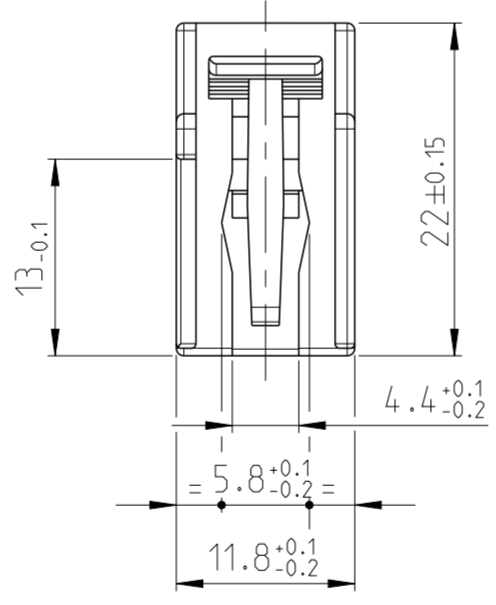
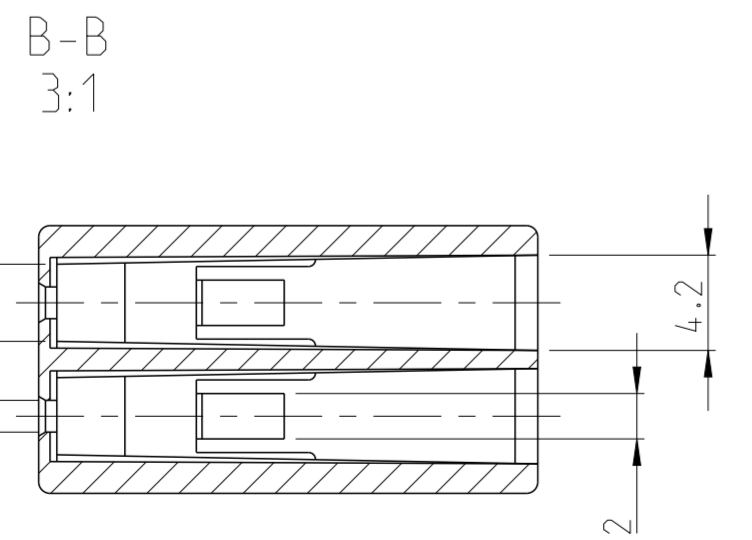

- 1 MATERIAL PA66-GF30
- 2 TE CONNECTIVITY TRADEMARK
- 3 DATE CODE
- 4 MOULD / MOULD CAVITY IDENTIFICATION NUMBER
- 5 P/N NUMBER AND REVISION

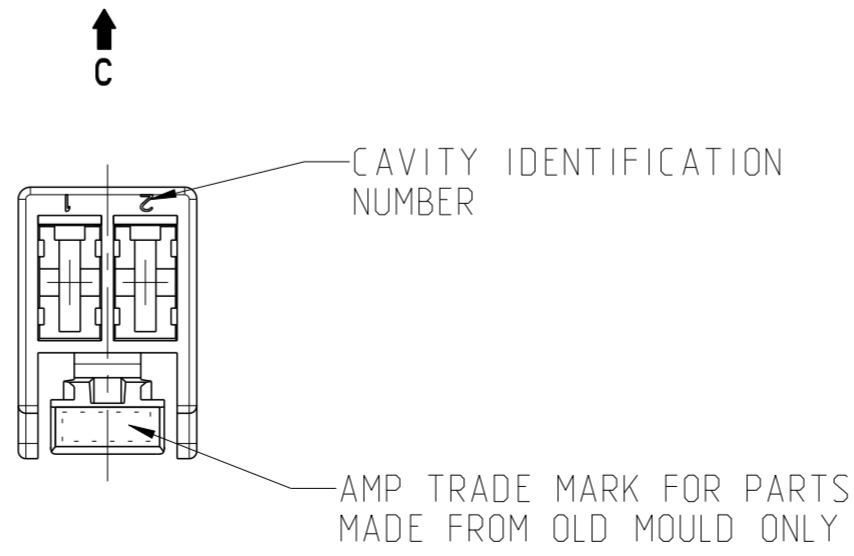

THIS DRAWING IS A CONTROLLED DOCUMENT.		DWN BASSANO 18JUN1987	STE TE Connectivity	
DIMENSIONS: mm		CHK TARTARI 25JUL1987		
TOLERANCES UNLESS OTHERWISE SPECIFIED:		APVD TARTARI 25JUL1987	NAME 5mm. PITCH RECEPTACLE CONN. HOUSING 2 POS.	
0 PLC ± 0.3	1 PLC ± 0.1	PRODUCT SPEC 108-20111	SIZE A2	CAGE CODE 00779
2 PLC ± 0.05	3 PLC ± -	APPLICATION SPEC -	DRAWING NO C-281871	RESTRICTED TO -
4 PLC ± -	ANGLES ± -	FINISH ± 0°30'	SCALE 2:1	SHEET 1 OF 1
MATERIAL SEE NOTE		WEIGHT -	CUSTOMER DRAWING	REV C1