

## Introduction

JSM50X family consists of different Hall switches produced in BCDMOS technology. All Hall sensors include a temperature-compensated Hall plate with active offset compensation, a comparator, and an output driver. The family consists of 3-wire devices, the corresponding output driver being an open-drain output transistor and a current source respectively. The comparator compares the actual magnetic flux with the fixed reference values (switching points). Accordingly the output transistor is switched on or off in 3-wire version. The active offset compensation leads to constant magnetic characteristics over supply voltage and temperature range. In addition, the magnetic parameters are robust against mechanical stress effects.

The sensors are designed for industrial and automotive applications and operate with supply voltages from 2.7 V to 30V in ambient temperature range from -40 °C up to 150 °C.

The family JSM50X is available in SOT23 and the leaded version TO92S packages.

## Features

- SOT23 and TO92S packages
- Low current consumptions of typ. 2.5 mA
- Operates from 2.7 V to 30 V supply voltage
- Overvoltage protection capability up to 40 V
- Highest ESD performance up to  $\pm 12$  kV
- Short-circuit protected open-drain output and thermal shut down for 3-wire applications
- Magnetic characteristics are robust regarding mechanical stress effects
- Constant switching points over a wide supply voltage and temperature range
- Wide operating temperature range from -40 °C to 150 °C
- The decrease of magnetic flux density caused by rising temperature in the sensor system is compensated by a built-in negative temperature coefficient of the magnetic characteristics
- Reverse-voltage protection at Vcc pin
- Ideal sensor for applications in extreme automotive and industrial environments
- Qualified according to AEC-Q100 test standard for automotive electronics industry to provide the highest quality expectation

## Applications

- Speed and RPM sensing
- Tachometer, counter pickup
- Flow-rate sensing
- Brushless dc motor commutation
- Motor and fan control
- Robotics control
- Proximity sensor
- Position sensor
- Seat position detection
- Seat belt buckles
- Hood/trunk/door latches
- Sun roof/convertible top/tailgate/liftgate actuation
- Brake/clutch pedals
- Electric power steering (EPS)
- Transmissions and shift selectors
- Wiper motor

## Package

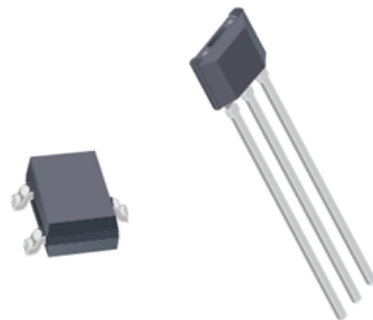

SOT23

TO92

**Contents**

<b>Section</b>	<b>Title</b>	<b>Page</b>
1.	JSM50X Family Overview	3
2.	Ordering Information	5
2.1	Marking Code	6
2.2	Operating Ambient Temperature Range	6
2.3	Hall Sensor Package Codes	6
3.	Functional Description	6
4.	Diagnostic Features	7
5.	Specifications	8
5.1	Outline Dimensions	8
5.2	Pin assignment	10
5.3	Absolute Maximum Ratings	10
5.4	ESD and Latch-up	11
5.5	Recommended Operating Conditions	11
5.6	Characteristics	12
5.7	Magnetic Characteristics Overview	13
6.	Magnetolectric conversion characteristics	13
7.	Application circui	14

## 1. JSM50X Family Overview

The types within each family differ according to the magnetic flux density values for the magnetic switching points, the temperature behavior of the magnetic switching points, the mode of switching, the number of pins and the average current consumption. Table 1 to Table 4 list some devices classified in terms of switching behavior and sensitivity: higher sensitivity correlates to lower switching points.

**Table 1: JSM50X 3-wire devices**

Type	Sensitivity	Switching Behavior	Sensitivity
JSM501		Bipolar	Very high
JSM502		Latching	Very high
JSM503		Unipolar	Very high
JSM504		Latching	High
JSM505		Latching	Medium
JSM506		Unipolar	Medium
JSM507		Unipolar	Low
JSM508		Unipolar	High
JSM509		Unipolar inverted	High
JSM510		Unipolar	Medium
JSM511		Unipolar	Medium

The following definitions outline the device behavior for different switching points:

### Latching Sensors:

**3-wire:** The output turns low with the magnetic south pole on the branded side of the package and turns high with the magnetic north pole on the branded side.

The output does not change if the magnetic field is removed. For changing the output state, the opposite magnetic field polarity must be applied.

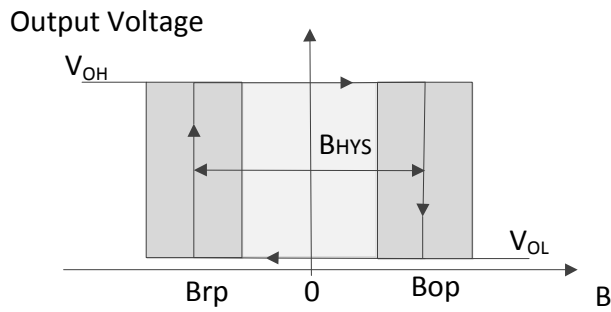

Fig. 1: Definition of magnetic switching points for 3-wire latching sensor.

**Bipolar Switching Sensors (3-wire only):**

The output turns low with the magnetic south pole on the branded side of the package and turns high with the magnetic north pole on the branded side. The output state is not defined if the magnetic field is removed again. Some sensors will change the output state and some sensors will not.

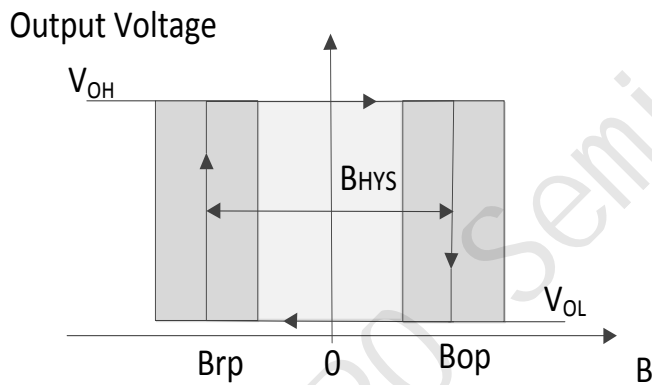

Fig. 2: Definition of magnetic switching points for 3-wire bipolar sensor.

**Unipolar Switching Sensors:**

**3-wire:** The output turns low with the magnetic south pole on the branded side of the package and turns high if the magnetic field is removed. The sensor does not respond to the magnetic north pole on the branded side.

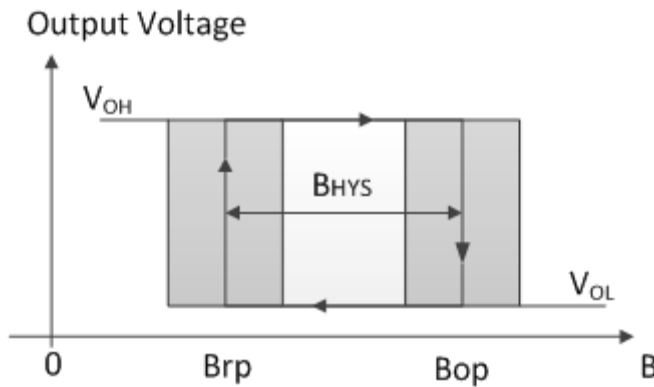

Fig. 3: Definition of magnetic switching points for 3-wire unipolar sensor.

**Unipolar Switching Sensors with Inverted Output:**

**3-wire:** The output turns high with the magnetic south pole on the branded side of the package and turns low if the magnetic field is removed. The sensor does not respond to the magnetic north pole on the branded side.

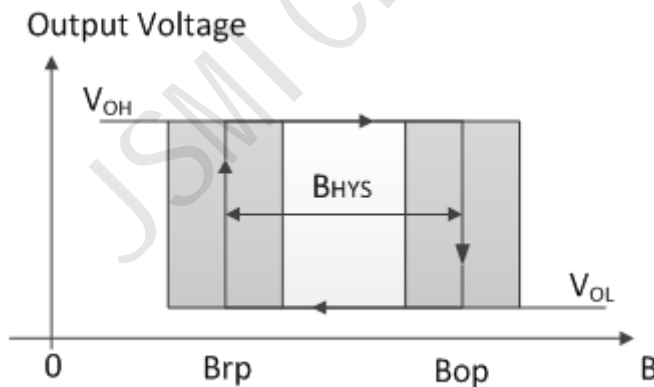

Fig. 4: Definition of magnetic switching points for 3-wire unipolar sensor with inverted output.

**2. Ordering Information**

### 2.1. Marking Code

All Hall sensors have a marking on the package surface (branded side). This marking includes the name of the sensor and date code.

### 2.2. Operating Ambient Temperature Range

The Hall sensors from Vinbelltech are specified to the ambient temperature.

$T_A = -40\text{ }^{\circ}\text{C}$  up to  $150\text{ }^{\circ}\text{C}$

### 2.3. Hall Sensor Package Codes

Hall sensors are available in a wide variety of packaging versions and quantities.

#### Ordering information

Part number	Package	Packing	Ambient, $T_A$
JSM50X	TO92S	Bulk, 1000 pieces/bag	$-40\text{ }^{\circ}\text{C}$ to $150\text{ }^{\circ}\text{C}$
JSM50X	SOT23	Tape&Reel, 3000 pieces/reel	$-40\text{ }^{\circ}\text{C}$ to $150\text{ }^{\circ}\text{C}$

## 3. Functional Description

JSM50X Hall effect sensor switches are available with different magnetic switching levels and output polarity.

JSM50X sensors are monolithic integrated circuits which switch in response to magnetic fields. If a magnetic field with flux lines perpendicular to the sensitive area is applied to the sensor, the biased Hall plate forces a Hall voltage proportional to this field.

The Hall voltage is compared with the actual threshold level in the comparator. If the magnetic field exceeds the threshold levels, the output stage (open drain output for 3-wire devices or current source for 2-wire devices) is switched to the appropriate state. The built-in hysteresis eliminates oscillation and provides switching behavior of output without bouncing.

Magnetic offset caused by mechanical stress is compensated by using the chopping offset compensation technique. A serial resistor or diode on the supply line is not required thanks to the built-in reverse voltage protection.

The open drain output is forced to a safe, high-impedance state (tri-state), in any of the following fault conditions: overtemperature, and undervoltage. In addition, the output current is limited (short-circuit protection).

The device is able to withstand a maximum supply voltage of 28 V for unlimited time and features overvoltage capability (40V load dump).

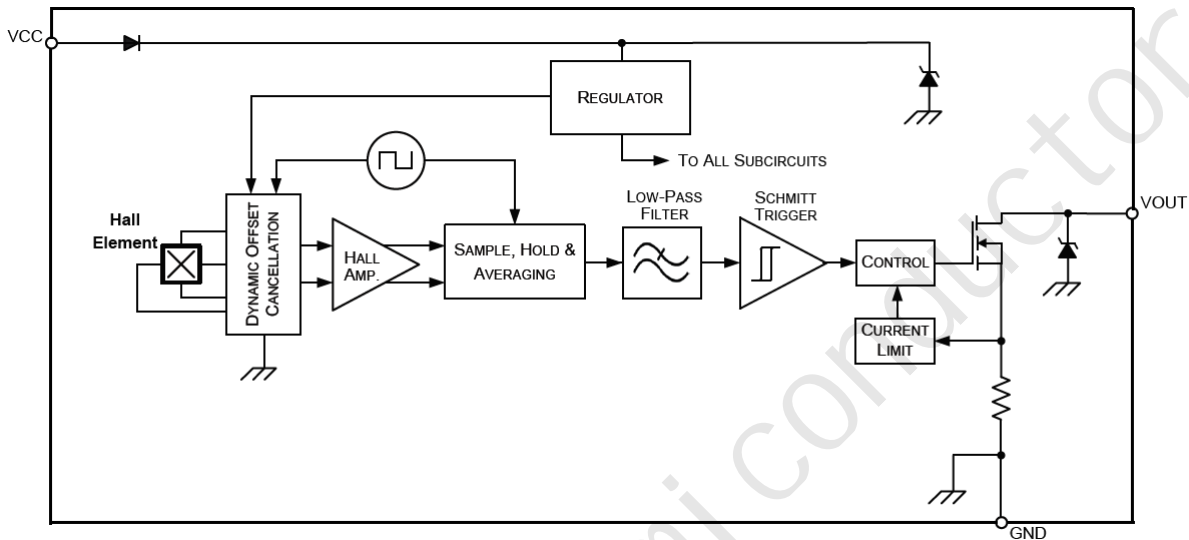

Fig. 5: JSM50x- 3-wire - Block diagram

#### 4. Diagnostic Features

Internal states are monitored and in an error condition flagged with a tri-state at the output (3-wire devices):

- Internal voltage regulator: under and over voltage detection
- Monitoring of internal bias and current levels
- Monitoring of the internal reference voltage
- Monitoring of the Hall plate voltage

## 5. Specifications

### 5.1. Outline Dimensions

#### T092S

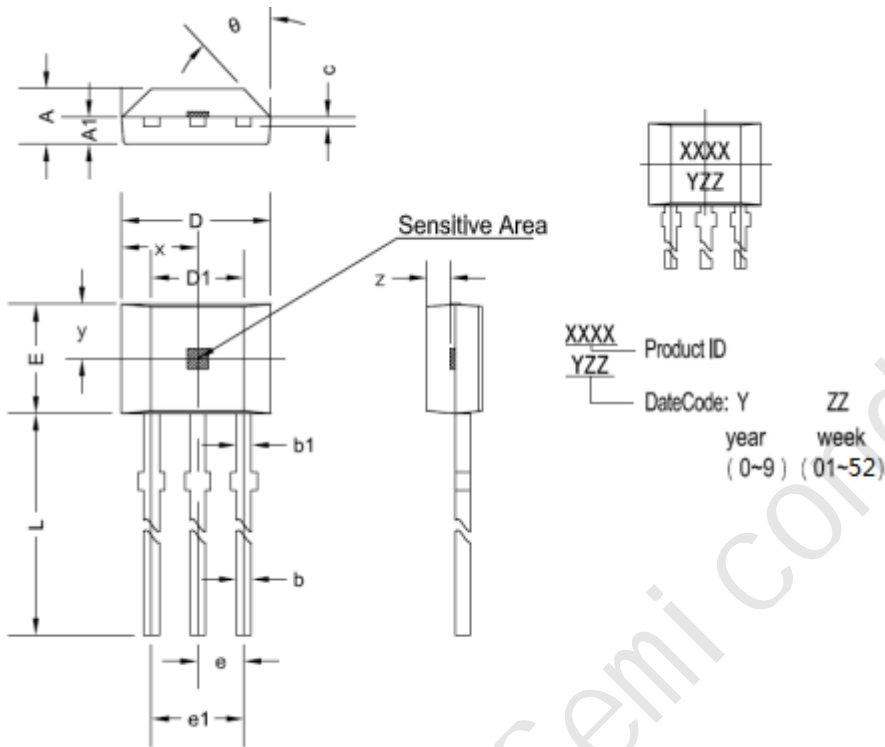

#### T092S dimensions

Symbol	Size (mm)		Size (in inches)	
	minimum	maximum	minimum	maximum
A	1.42	1.67	0.056	0.066
A1	0.66	0.86	0.026	0.034
b	0.35	0.56	0.014	0.022
b1	0.4	0.55	0.016	0.022
C	0.36	0.51	0.014	0.02
D	3.9	4.2	0.154	0.165
D1	2.97	3.27	0.117	0.129
E	2.9	3.28	0.114	0.129
e	1.270 TYP		0.050 TYP	
e1	2.44	2.64	0.096	0.104
L	13.5	15.5	0.531	0.61
x	2.025TYP		0.080TYP	
y	1.545TYP		0.061TYP	
z	0.500TYP		0.020TYP	
θ	45°TYP		45°TYP	

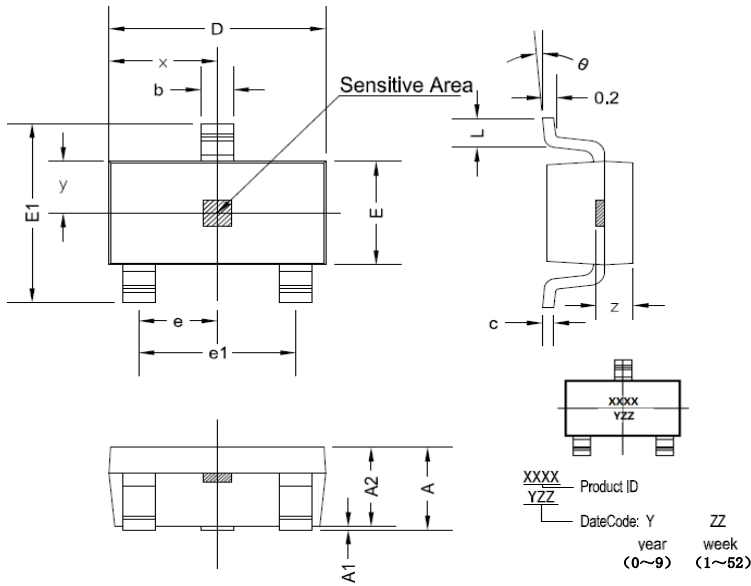

**SOT23**

**SOT23 dimensions**

Symbol	Size (mm)		Size (in inches)	
	minimum	maximum	minimum	minimum
A	1.05	1.25	0.041	0.049
A1	0	0.1	0	0.004
A2	1.05	1.15	0.041	0.045
b	0.3	0.5	0.012	0.02
c	0.100	0.2	0.004	0.008
D	2.82	3.02	0.111	0.119
E	1.5	1.7	0.059	0.067
E1	2.65	2.95	0.104	0.116
e	0.950 TYP		0.037 TYP	
e1	1.8	2	0.071	0.079
L	0.3	0.6	0.012	0.024
x	1.460TYP		0.057TYP	
y	0.800TYP		0.032TYP	
z	0.600TYP		0.024TYP	
θ	0°	8°	0°	8°

### 5.2. Pin assignment

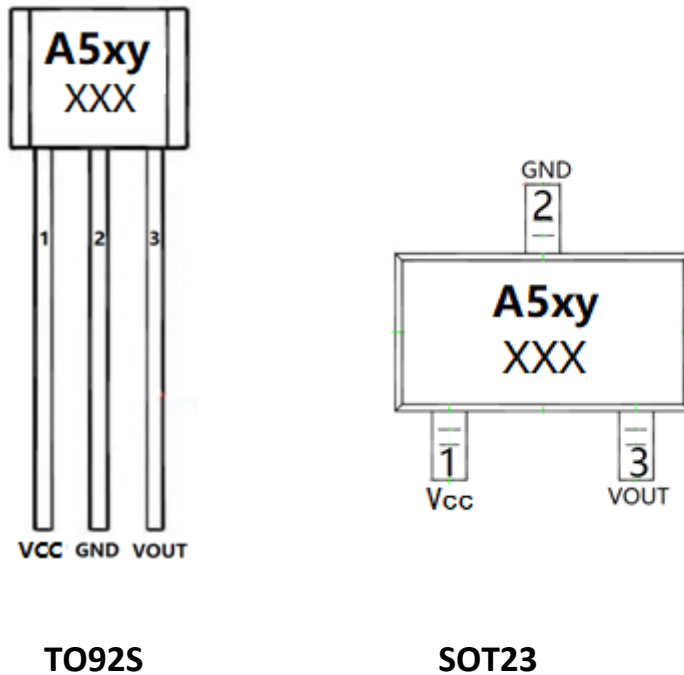

Fig.6: Pin assignment of TO92S and SOT23

Pin assignment

Pin number	Name	Function
1	VCC	Power supply
2	GND	Ground
3	Vout	Output

### 5.3. Absolute Maximum Ratings

Stresses beyond those listed in the “Absolute Maximum Ratings” may cause permanent damage to the device. This is a stress rating only. Functional operation of the device at these conditions is not implied. Exposure to absolute maximum rating conditions for extended periods will affect device reliability.

This device contains circuitry to protect the inputs and outputs against damage due to high static voltages or electric fields; however, it is advised that normal precautions be taken to avoid application of any voltage higher than absolute maximum-rated voltages to this circuit.

All voltages listed are referenced to ground (GND).

Symbol	Parameter	Pin No	Min.	Max.	Unit	Conditions
V <sub>CC</sub>	Supply voltage	1	-20	32	V	t < 1000 h <sup>1)</sup>
				34	V	t < 96 h <sup>1)</sup>
				36	V	t < 5 min <sup>1)</sup>
				40	V	t < 5 x 400 ms <sup>1)</sup> with series resistor R <sub>V</sub> > 100 Ω
V <sub>OUT</sub>	Output voltage	3	-0.5	32	V	t < 1000 h <sup>1)</sup>
				34	V	t < 96 h <sup>1)</sup>
				36	V	t < 5 min <sup>1)</sup>
				40	V	t < 5 x 400 ms <sup>1)</sup> with series resistor R <sub>L</sub> > 100 Ω
I <sub>O</sub>	Output current	3		65	mA	
I <sub>OR</sub>	Reverse output current	3	-50		mA	
T <sub>A</sub>	Ambient temperature range		-40	170	°C	t < 96 h <sup>1)</sup>
1) No cumulative stress						

#### 5.4. ESD and Latch-up

The output pin has to be in tri-state (high impedance) for ESD measurements.

ESD and latch-up

Symbol	Parameter	Min	Max	Unit
I <sub>latch</sub>	Maximum latch-up free current at any pin (measurement according to AEC Q100-004), class 1	-100	100	mA
V <sub>HBM</sub>	Human body model (according to AEC Q100-002)	-12	12	kV

#### 5.5. Recommended Operating Conditions

Functional operation of the device beyond those indicated in the “Recommended Operating Conditions” of this specification is not implied, may result in unpredictable behavior of the device and may reduce reliability and lifetime.

All voltages listed are referenced to ground (GND).

Symbol	Parameter	Pin No	Min	Typ	Max	Unit	Conditions
$V_{CC}$	Supply voltage	1	2.7		30	V	3-wire
$T_A$	Ambient temperature range		-40		150	°C	
$V_{OUT}$	Output voltage	3			30	V	
$I_{OUT}$	Output current	3			25	mA	

### 5.6. Characteristics

at  $T_A = -40\text{ }^{\circ}\text{C}$  to  $150\text{ }^{\circ}\text{C}$ ,  $V_{CC} = 3.0\text{ V}$  to  $24\text{ V}$ , at Recommended Operation Conditions if not otherwise specified in the column "Conditions". Typical Characteristics for  $T_A = 25\text{ }^{\circ}\text{C}$  and  $V_{CC} = 12\text{ V}$

Symbol	Parameter	Pin No	Min	Typ	Max	Unit	Conditions
<b>Supply</b>							
$I_{CC}$	Supply current	1		2.5	3.2	mA	3-wire
$I_{CCR}$	Reverse current				1	mA	for $V_{CC} = -18\text{ V}$
<b>Port Output</b>							
$V_{OL}$	Port low output voltage	3		0.13	0.4	V	$I_O = 20\text{ mA}$
					0.5	V	$I_O = 25\text{ mA}$
$t_f$	Output fall time				1	$\mu\text{s}$	$V_{CC} = 12\text{ V}$ ; $R_L = 820\ \Omega$ ; $C_L = 20\text{ pF}$
$t_r$	Output rise time				1	$\mu\text{s}$	
$B_{noise}$	Effective noise of magnetic switching points			0.1		mT	For square wave signal with 1 kHz
$t_j$	Output jitter				$\pm 0.5$	$\mu\text{s}$	For square wave signal with 1 kHz
$t_d$	Delay time			16		$\mu\text{s}$	
$t_{samp}$	Output refresh period		1.6	2	2.66	$\mu\text{s}$	
$t_{en}$	Enable time of output after settling of $V_{CC}$			50		$\mu\text{s}$	$V_{CC} = 12\text{ V}$ $B > B_{on} + 2\text{ mT}$ or $B < B_{off} - 2\text{ mT}$

### 5.7. Magnetic Characteristics Overview

$T_A = -40\text{ }^\circ\text{C}$  to  $150\text{ }^\circ\text{C}$ ,  $V_{CC} = 3.0\text{ V}$  to  $30\text{ V}$ ,  $GND = 0\text{ V}$ , recommended operation conditions if not otherwise specified in the column "Conditions". Typical characteristics for  $T_A = 25\text{ }^\circ\text{C}$ .

Sensor	Switching Type	Temp. coeff. of magnetic thresh. $T_C$ [ppm/K]	On point $B_{ON}$ [mT]			Off point $B_{OFF}$ [mT]			Hysteresis $B_{HYS}$ ① [mT]		
			Min	Typ	Max	Min	Typ	Max	Min	Typ	Max
<b>3-wire</b>											
JSM501	bipolar	0		0.9			-0.9			1.8	
JSM502	latching	-1000		2.5			-2.5			5.0	
JSM503	unipolar	-1000		5.5			3.5			2.0	
JSM504	latching	-1000		8.0			-8.0			16.0	
JSM505	latching	-1000		13.5			-13.5			27.0	
JSM506	unipolar	-1000		18.0			16.0			2.0	
JSM507	unipolar	-300		27.0			23.0			4.0	
JSM508	unipolar	-1000		-5.5			-3.5			2.0	
JSM509	unipolar	-1000		3.5			5.5			2.0	
JSM510	unipolar	-1000		10			8			2.0	
JSM511	unipolar	-1000		8			10		-	2.0	-

### 6. Magnetolectric conversion characteristics

Apply a magnetic field greater than  $B_{op}$  on the seal side of TO92S package (near the South Pole), and the output becomes low; Apply a magnetic field less than  $B_{rp}$  (near the North Pole) and the output becomes high. When the chip is first powered on, if the magnetic field is between the  $B_{op}$  and the  $B_{rp}$ , the output state is in an undefined state (high or low). The magnetic field polarity of the operating and releasing points of SOT23 package is opposite to that of TO92S. See below.

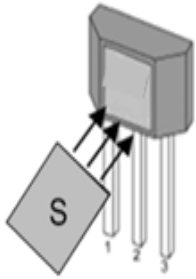

$V_{OUT}=low$

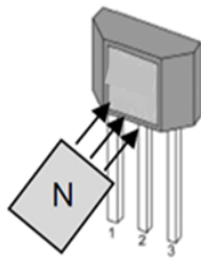

$V_{OUT}=high$

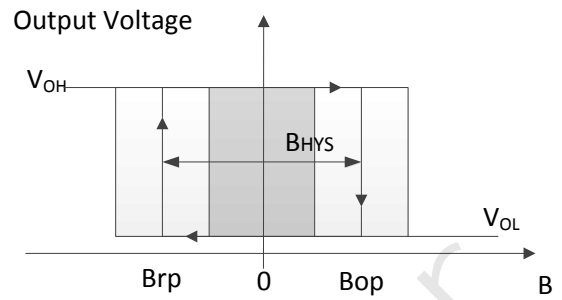

TO92S output state

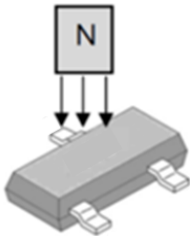

$V_{OUT}=low$

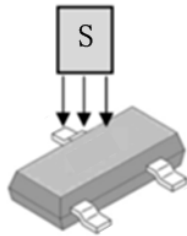

$V_{OUT}=high$

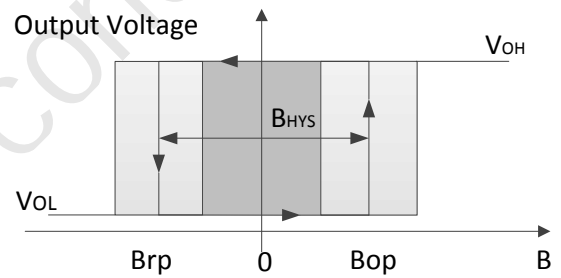

SOT23 output state

**7. Application circuit**

**3-Wire Devices**

Typical application circuit (see Fig.7)

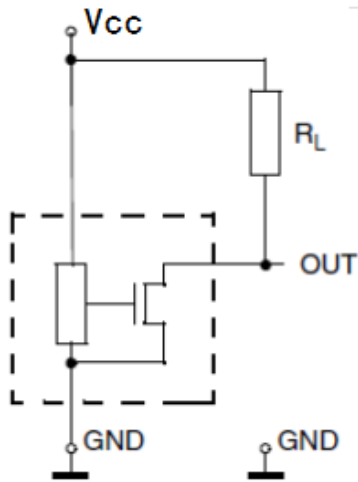

Fig. 7: Example 3-wire application circuit 1

For applications with disturbances on the supply line or radiated disturbances, a series resistor  $R_V$  and two capacitors  $C_P$  and  $C_L$  all placed close to the sensor are recommended (see Fig.8).

For example:  $R_V = 100$  ohms,  $C_P = 4.7$  nF, and  $C_L = 1$  nF.

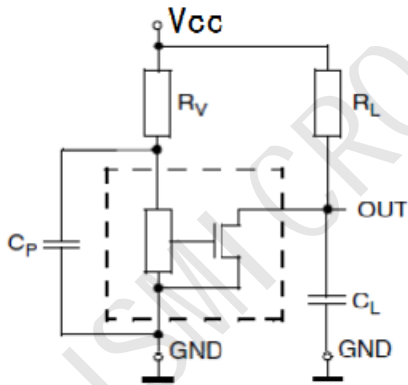

Fig. 8: Example 3-wire application circuit 2