

规格書

SPECIFICATION

Customer : 深圳市立創電子商務有限公司

Part Name: E-CAP

SPEC : RF Series

Part NO. : ALL

Date : 2021-8-31

CUSTOMER SIGN		

TOPAZCON	
DRAWING	RATIFY
李梦如	<i>Cocp</i>

RF Series

- Longer life, better performance, cost effective.
- Endurance: +105°C 6000 hours
- RoHS Compliant

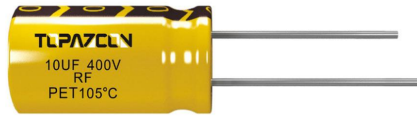

◆ SPECIFICATIONS

Item	Performance Characteristics							
Temperature Range	-25 to +105°C (160 to 450Vdc)							
Working Voltage Range	160 to 450Vdc							
Capacitance Range	1.0 to 150 μ F							
Capacitance	±20% (at 20°C and 120Hz)							
Dissipation Factor (tan δ)	Rated Voltage (V)	160	200	250	350	400	450	
	Tan δ (Max)	0.15	0.15	0.15	0.20	0.20	0.20	
Low Temperature Characteristics (Max. Impedance Ratio)	Rate voltage (V)	160	200	250	350	400	450	
	Z(-25°C)/Z(+20°C)	3	3	3	5	5	6	
	Z(-40°C)/Z(+20°C)	6	6	6	6	6	15	
Leakage Current	160 to 400Vdc	450 Vdc					(at 20°C after 2 minutes)	
	$I \leq 0.02CV + 10\mu A$	$I \leq 0.03CV + 10\mu A$						
Endurance	Where, I: Max. Leakage current (u A); C: Nominal capacitance (u F); V: Rated voltage (V).							
	After application of the rated DC voltage with rated ripple current (the voltage peak is no more than rated voltage) at 105°C 6000 hours, measuring the parameters when the capacitors are restored to 20°C, the capacitors shall meet the requirements as below.							
	Capacitance change	$\leq \pm 20\%$ of the initial value						
	Dissipation factor (tan δ)	$\leq 200\%$ of the specified value						
Shelf Life	The following specifications shall be satisfied when the capacitor are restored to 20°C after exposing them for 1000 hours at 105°C without voltage applied.							
	Capacitance change	$\leq \pm 20\%$ of the initial value						
	Dissipation factor (tan δ)	$\leq 200\%$ of the specified value						
	Leakage current	$\leq 200\%$ of the specified value						

◆ DIMENSIONS (mm)

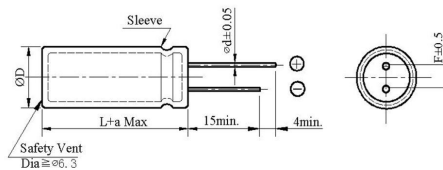

ΦD	6.3	8	10	12.5	16	18
Φ d	0.5	0.5	0.6	0.6	0.6	0.8
F	2.5	3.5	3.5	5.0	5.0	7.5
a	+2max					

◆ RIPPLE CURRENT MULTIPLIERS

Frequency correction factor for ripple current (Hz)

Freq. (Hz)	120	1K	10K	100K
WV (Vdc)				
160 to 450	0.50	0.80	0.90	1.00

RF Series

◆ STANDARD RATINGS

WV (Vdc)	Cap (uF)	Case size ∅ D×L (mm)	Tan δ	Ripple current (mA _{rms} /105°C, 100KHz)
160V (2C)	1.0	6.3×9	0.15	36
		6.3×12	0.15	40
	1.5	6.3×12	0.15	50
		6.3×9	0.15	50
	1.8	6.3×12	0.15	56
		6.3×9	0.15	56
	2.2	6.3×12	0.15	60
		6.3×9	0.15	62
	2.8	6.3×12	0.15	68
		6.3×9	0.15	67
	3.3	6.3×12	0.15	72
		6.3×12	0.15	75
	4.7	8×12	0.15	80
		6.3×12	0.15	79
	5.6	8×12	0.15	84
		8×9	0.15	89
	6.8	8×12	0.15	96
		8×9	0.15	105
	8.2	8×12	0.15	110
		8×9	0.15	165
	10	8×12	0.15	206
		8×12	0.15	230
	15	8×16	0.15	250
		8×16	0.15	340
22	8×20	0.15	400	
	10×16	0.15	420	
33	10×20	0.15	450	
	10×16	0.15	460	
47	10×20	0.15	500	
	12.5×16	0.15	570	
68	12.5×20	0.15	630	
	12.5×20	0.15	680	
100	12.5×25	0.15	720	
	16×20	0.15	760	
150	16×25	0.15	850	
	6.3×9	0.15	38	
1.0	6.3×12	0.15	42	
	6.3×9	0.15	50	
1.5	6.3×12	0.15	54	
	6.3×9	0.15	54	
1.8	6.3×12	0.15	60	
	6.3×9	0.15	60	
2.2	6.3×12	0.15	68	
	6.3×9	0.15	68	
2.8	6.3×12	0.15	71	
	6.3×9	0.15	74	
3.3	6.3×12	0.15	80	
	6.3×12	0.15	90	
4.7	8×12	0.15	95	
	8×9	0.15	92	
5.6	8×12	0.15	98	
	8×9	0.15	98	
6.8	8×12	0.15	110	
	8×12	0.15	115	
8.2	8×16	0.15	120	
	8×12	0.15	185	
10	8×16	0.15	210	

WV (Vdc)	Cap (uF)	Case size ∅ D×L (mm)	Tan δ	Ripple current (mA _{rms} /105°C, 100KHz)
200V (2D)	15	8×16	0.15	250
		8×20	0.15	268
	22	8×20	0.15	400
		10×16	0.15	400
	33	10×20	0.15	450
		12.5×20	0.15	610
	47	12.5×20	0.15	635
		12.5×25	0.15	700
	68	16×20	0.15	735
		16×25	0.15	800
	100	16×25	0.15	855
		16×30	0.15	900
	150	6.3×9	0.15	40
		6.3×12	0.15	46
	1.0	6.3×9	0.15	54
6.3×12		0.15	58	
1.5	6.3×9	0.15	59	
	6.3×12	0.15	63	
1.8	6.3×9	0.15	71	
	6.3×12	0.15	75	
2.2	6.3×9	0.15	73	
	6.3×12	0.15	78	
2.8	6.3×9	0.15	78	
	6.3×12	0.15	83	
3.3	6.3×9	0.15	91	
	6.3×12	0.15	102	
4.7	8×9	0.15	95	
	8×12	0.15	105	
5.6	8×12	0.15	109	
	8×16	0.15	115	
6.8	8×12	0.15	116	
	8×16	0.15	120	
8.2	8×12	0.15	170	
	8×16	0.15	210	
10	8×20	0.15	310	
	8×20	0.15	310	
15	8×20	0.15	390	
	10×16	0.15	400	
22	10×20	0.15	480	
	12.5×20	0.15	530	
33	12.5×20	0.15	627	
	16×20	0.15	660	
47	16×25	0.15	720	
	16×25	0.15	800	
68	16×30	0.15	880	
	16×30	0.15	930	
100	16×35	0.15	1030	

RF Series

◆ STANDARD RATINGS

WV (Vdc)	Cap (uF)	Case size ∅ D×L (mm)	Tan δ	Ripple current (mArms/105°C, 100KHz)
350V (2V)	1.0	6.3×9	0.20	58
		6.3×12	0.20	65
	1.5	6.3×9	0.20	68
		6.3×12	0.20	72
	1.8	6.3×9	0.20	74
		6.3×12	0.20	80
	2.2	6.3×9	0.20	85
		6.3×12	0.20	90
	2.8	8×9	0.20	101
		8×12	0.20	106
	3.3	8×9	0.20	106
		8×12	0.20	110
	4.7	8×12	0.20	115
		8×16	0.20	120
	5.6	8×12	0.20	130
		8×16	0.20	150
	6.8	8×16	0.20	160
		8×20	0.20	170
	8.2	8×20	0.20	189
		8×20	0.20	230
15	10×20	0.20	310	
	12.5×20	0.20	430	
33	12.5×20	0.20	515	
	12.5×25	0.20	535	
47	16×20	0.20	650	
	18×20	0.20	726	
82	18×25	0.20	910	
	6.3×9	0.20	70	
1.0	6.3×12	0.20	75	
	6.3×12	0.20	78	
1.5	8×12	0.20	80	
	6.3×12	0.20	85	
1.8	8×12	0.20	90	
	6.3×12	0.20	88	
2.2	8×12	0.20	105	
	8×12	0.20	107	
2.8	8×16	0.20	109	
	8×12	0.20	108	
3.3	8×16	0.20	112	
	8×12	0.20	114	
4.7	8×16	0.20	120	
	8×16	0.20	145	
5.6	8×20	0.20	155	
	8×20	0.20	170	
6.8	10×12	0.20	160	
	10×16	0.20	210	
8.2	10×20	0.20	230	

WV (Vdc)	Cap (uF)	Case size ∅ D×L (mm)	Tan δ	Ripple current (mArms/105°C, 100KHz)
400V (2G)	10	10×16	0.20	225
		10×20	0.20	280
	12	10×20	0.20	290
		10×20	0.20	300
	15	12.5×20	0.20	320
		12.5×20	0.20	390
	22	12.5×25	0.20	450
		16×25	0.20	550
	33	16×25	0.20	640
		16×30	0.20	670
	47	16×30	0.20	680
		16×35	0.20	720
	68	18×30	0.20	800
		18×35	0.20	930
	100	18×40	0.20	950
1.0		8×12	0.20	72
450V (2W)	1.5	8×12	0.20	75
	1.8	8×12	0.20	90
	2.2	8×12	0.20	103
		8×16	0.20	115
	2.8	8×12	0.20	115
		8×16	0.20	120
	3.3	8×16	0.20	128
	4.7	8×20	0.20	140
	5.6	10×16	0.20	158
	6.8	10×16	0.20	180
		10×20	0.20	200
	8.2	10×20	0.20	230
	10	10×20	0.20	250
	15	12.5×20	0.20	350
	22	12.5×25	0.20	450
	33	16×25	0.20	550
	47	16×35	0.20	700
	68	18×30	0.20	810
	100	18×40	0.20	950

物料编码原则 Part Number System

1	2	3	4	5	6	7	8	9	10	11	12	13	14	15	16	17
E	R	G	2	D	1	5	0	M	1	0	1	3	0	0	Y	
①	②		③		④			⑤	⑥			⑦		⑧	⑨	
分类	系列		电压		容量			误差	直径		高度		引脚		颜色	其他
Category	Series		Voltage		Capacitance			Tol.	Dia.		Length		Terminal		Colour	Other

①分类Category

编码Code	代码Code	种类Type	备注Remark
1	E	Electrolytic Capacitor	铝电解电容
	P	Conductive Polymer	导电高分子固体铝
	S	super-capacitor	超级电容

②系列Series			③电压Voltage			④容量Capacitance			⑤Tolerance		⑥尺寸Size				⑦引脚Terminal			
系列series	编码Code		电压WV	编码Code		容量Cap	编码Code			容量误差Tolerance	编码Code	尺寸Size	直径编码Dia. Code		高度编码Length Code		形式Specification	编码Code
	2	3		4	5		6	7	8				10	11	12	13		
SM	S	M	4	0	G	0.1	R	1	0	-5~+5	J	3×5	0	3	0	5	Bulk packing	00
SS	S	S	6.3	0	J	0.22	R	2	2	-10~+10	K	4×5	0	4	0	5	Φ4-18 Taping	T1
NP	N	P	10	1	A	0.33	R	3	3	-20~+20	M	5×5	0	5	0	5		T2
LL	L	L	16	1	C	0.47	R	4	7	-5~+20	F	6.3×5	0	6	0	5		T3
RD	R	D	25	1	E	1	1	R	0	-10~+20	V	4×7	0	4	0	7		T4
RE	R	E	35	1	V	2.2	2	R	2	-10~+30	Q	5×7	0	5	0	7	Lead Cut	F
RT	R	T	40	1	G	3.3	3	R	3	-20~+0	S	6.3×7	0	6	0	7		C
RF	R	F	50	1	H	4.7	4	R	7	-0~+20	A	8×7	0	8	0	7		R
RG	R	G	55	1	I	6.8	6	R	8			5×11	0	5	1	1		Y
RJ	R	J	63	1	J	10	1	0	0			6.3×11	0	6	1	1		M
RR	R	R	70	1	L	22	2	2	0			8×12	0	8	1	2		X
LF	L	F	80	1	K	33	3	3	0			8×16	0	8	1	6		Z
LJ	L	J	100	2	A	47	4	7	0			10×12	1	0	1	2		K
LR	L	R	120	2	B	100	1	0	1			10×16	1	0	1	6		
LG	L	G	140	2	L	220	2	2	1			8×20	0	8	2	0		
RS	R	S	160	2	C	330	3	3	1			10×20	1	0	2	0		
RN	R	N	180	2	Q	470	4	7	1			13×20	1	3	2	0		
RV	R	V	200	2	D	560	5	6	1			13×25	1	3	2	5		
LH	L	H	220	2	N	1000	1	0	2			16×25	1	6	2	5		
TE	T	E	250	2	E	1500	1	5	2			16×32	1	6	3	2		
TF	T	F	300	2	S	2200	2	2	2			16×36	1	6	3	6		
TG	T	G	315	2	F	3300	3	3	2			18×32	1	8	3	2		
LP	L	P	350	2	V	4700	4	7	2			18×36	1	8	3	6		
LT	L	T	385	2	P	6800	6	8	2			18×40	1	8	4	0		
LS	L	S	400	2	G	10000	1	0	3									
LV	L	V	420	2	T	15000	1	5	3									
			450	2	W	22000	2	2	3									
			500	2	H	33000	3	3	3									
			550	2	J	56000	5	6	3									
			600	2	K	68000	6	8	3									

⑧颜色代码 Colour Code

编码Code	颜色	黑色	黄色	墨绿色	淡绿色	橙色	白色	紫色
16	Colour	Black	Yellow	Ink Green	Light Green	Orange	White	Purple
	代码Code	B	Y	I	L	O	W	P

⑨特殊代码 Other

用于标记客户特殊要求

Used to mark special requirements of customers

焊接温度及注意事项 Solder temperature and notes

●无铅波峰焊 Ware soldering(lead-free)

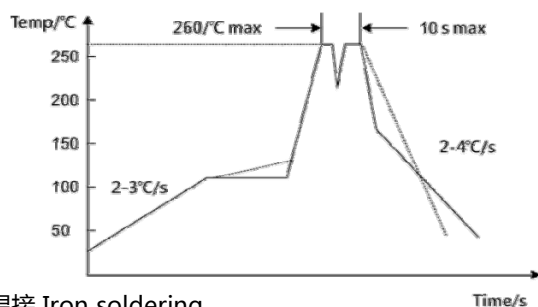

注意事项 notes:

- ①PCB主面预热温度最高升温斜率:2→3°C / sec, 预热时长:120s左右;
- ②PCB主面预热温度范围:90-130°C;
- ③PCB背面最高预热温度不超过130°C;
- ④波峰温度与预热区温度落差不能大于150°C.
- ⑤波峰焊锡炉温度应控制在250-260°C 之间;
- ⑥波谷温度最好不能低于217°C, 也就是说如果是双波峰, 两个波峰之间落差不能大于60度, 以防造成二次焊接;
- ⑦焊接时间:双波波峰"1"控制在0.5-2s 之间, 波峰"11"的时间控制在1.5-4s 之间, 合计时间:2-6s. 单波时间控制在2-6s.
- ⑧冷却区斜率一般指从最高温降到90°C时间平均负斜率-4→-2°C/s

●烙铁焊接 Iron soldering

烙铁作业:最高温度: 350 ± 5°C, 焊接时间: 3±0.5 秒

Lead Forming

Taping Specifications

Fig.1 Code:T1

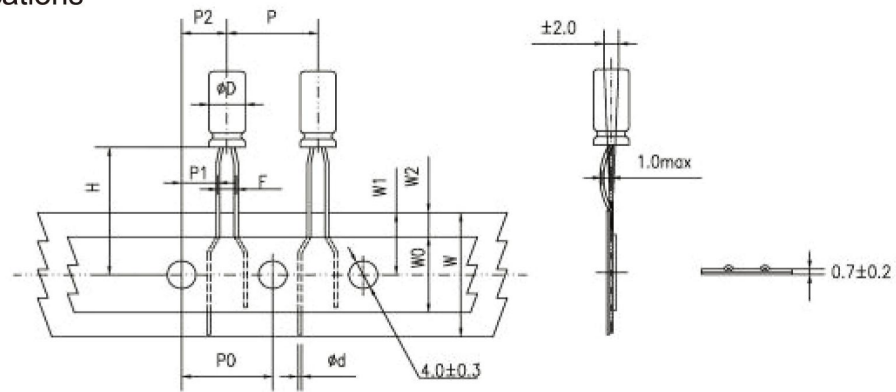

Fig.2 Code:T2

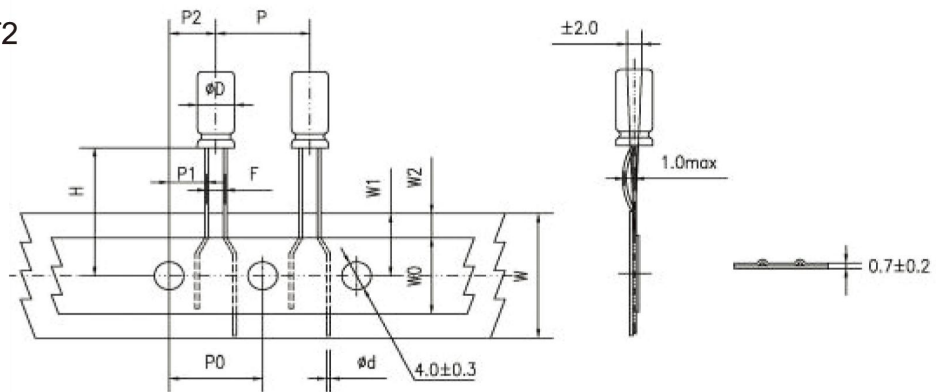

Fig.3 Code:T2

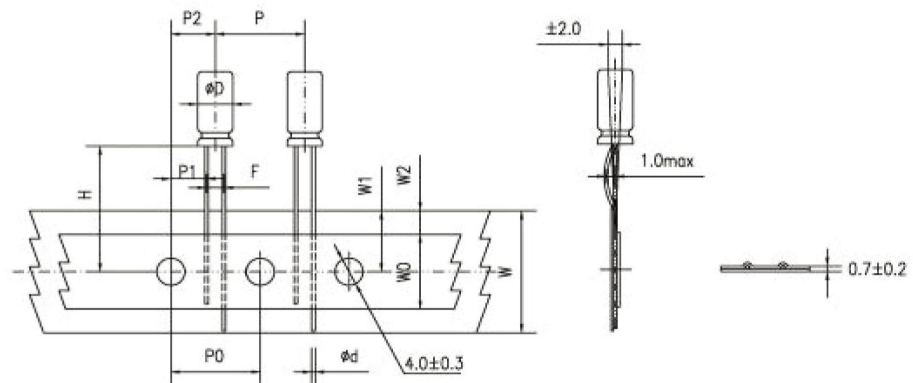
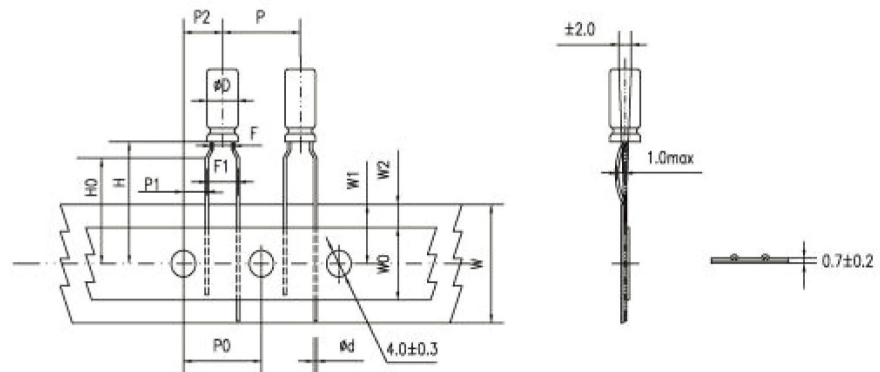

Fig.4 Code:T3



Specification Fig.1 & Fig.2 & Fig.3

Items	Symbol	CASE SIZE										Tolerance			
		4 × 5 4 × 7		5 × 5 5 × 7		5x11		6.3x5	6.3x7 6.3x9	6.3x11 6.3x12	8x5/7 8x9/11 8x11.5 8x12		8x16 8x20	10x9/12 10x12.5 10x13/16 10x20/25	
Pin Code		T ₁	T ₂	T ₁	T ₂	T ₁		T ₂	T ₂	T ₂	T ₂	T ₂	T ₂		
Lead wire diameter	φd	0.45		0.45		0.5		0.45	0.5	0.5	0.5	0.45/0.5	0.6	0.6	± 0.05
Pitch of body	P	12.7		12.7		12.7		12.7	12.7	12.7	12.7	12.7	12.7	12.7	± 1.0
Feed hole pitch	PO	12.7		12.7		12.7		12.7	12.7	12.7	12.7	12.7	12.7	12.7	± 0.2
Hole center to lead distance	P1	5.1	5.6	5.1	5.35	5.1	5.35	5.1	5.1	5.1	5.1	4.6	4.6	3.85	± 0.7
Feed hole center to body center distance	P2	6.35		6.35		6.35		6.35	6.35	6.35	6.35	6.35	6.35	6.35	± 1.0
Lead to lead distance	F	2.5	1.5	2.5	2.0	2.5	2.0	2.5	2.5	2.5	2.5	3.5	3.5	5.0	± 0.5
Height of body from tape center	H	18.5		18.5		18.5		18.5	18.5	18.5	18.5	18.5	18.5	18.5	± 0.75
Base tape width	W	18.0		18.0		18.0		18.0	18.0	18.0	18.0	18.0	18.0	18.0	± 0.5
Adhesive tape width	WO	11.0		11.0		11.0		11.0	11.0	11.0	11.0	11.0	11.0	11.0	min
Hole positron	W1	9.0		9.0		9.0		9.0	9.0	9.0	9.0	9.0	9.0	9.0	+0.75 -0.5
Hole down tape position	W2	3.0		3.0		3.0		3.0	3.0	3.0	3.0	3.0	3.0	3.0	max

Specification Fig.4

Items	Symbol	CASE SIZE									Tolerance
		4 × 5 4 × 7	5 × 5	5 × 7	5 × 11	6.3 × 5	6.3 × 7 6.3 × 9	6.3 × 11 6.3 × 12	8 × 5/7 8 × 9/11 8 × 11.5/12	8 × 16 8 × 20	
Pin Code		T ₃	T ₃	T ₃	T ₃	T ₃	T ₃	T ₃	T ₃	T ₃	
Lead wire diameter	φd	0.45	0.45	0.45	0.5	0.45	0.5	0.5	0.45/0.5	0.6	± 0.05
Pitch of body	P	12.7	12.7	12.7	12.7	12.7	12.7	12.7	12.7	12.7	± 1.0
Feed hole pitch	PO	12.7	12.7	12.7	12.7	12.7	12.7	12.7	12.7	12.7	± 0.2
Hole center to lead distance	P1	3.85	3.85	3.85	3.85	3.85	3.85	3.85	3.85	3.85	± 0.7
Feed hole center to body center distance	P2	6.35	6.35	6.35	6.35	6.35	6.35	6.35	6.35	6.35	± 1.0
Lead to lead distance	F	1.5	2.0	2.0	2.0	2.5	2.5	2.5	3.5	3.5	± 0.5
Lead to lead distance	F1	5.0	5.0	5.0	5.0	5.0	5.0	5.0	5.0	5.0	+0.8 -0.2
Height of body from tape center	H	18.5	18.5	18.5	18.5	18.5	18.5	18.5	18.5	18.5	± 0.75
Lead wire clinch height	HO	16.0	16.0	16.0	16.0	16.0	16.0	16.0	16.0	16.0	± 0.5
Base tape width	W	18.0	18.0	18.0	18.0	18.0	18.0	18.0	18.0	18.0	± 0.5
Adhesive tape width	WO	11.0	11.0	11.0	11.0	11.0	11.0	11.0	11.0	11.0	min
Hole position	W1	9.0	9.0	9.0	9.0	9.0	9.0	9.0	9.0	9.0	+0.75 -0.5
Hole down tape position	W2	3.0	3.0	3.0	3.0	3.0	3.0	3.0	3.0	3.0	max

● Lead Forming & Cut:

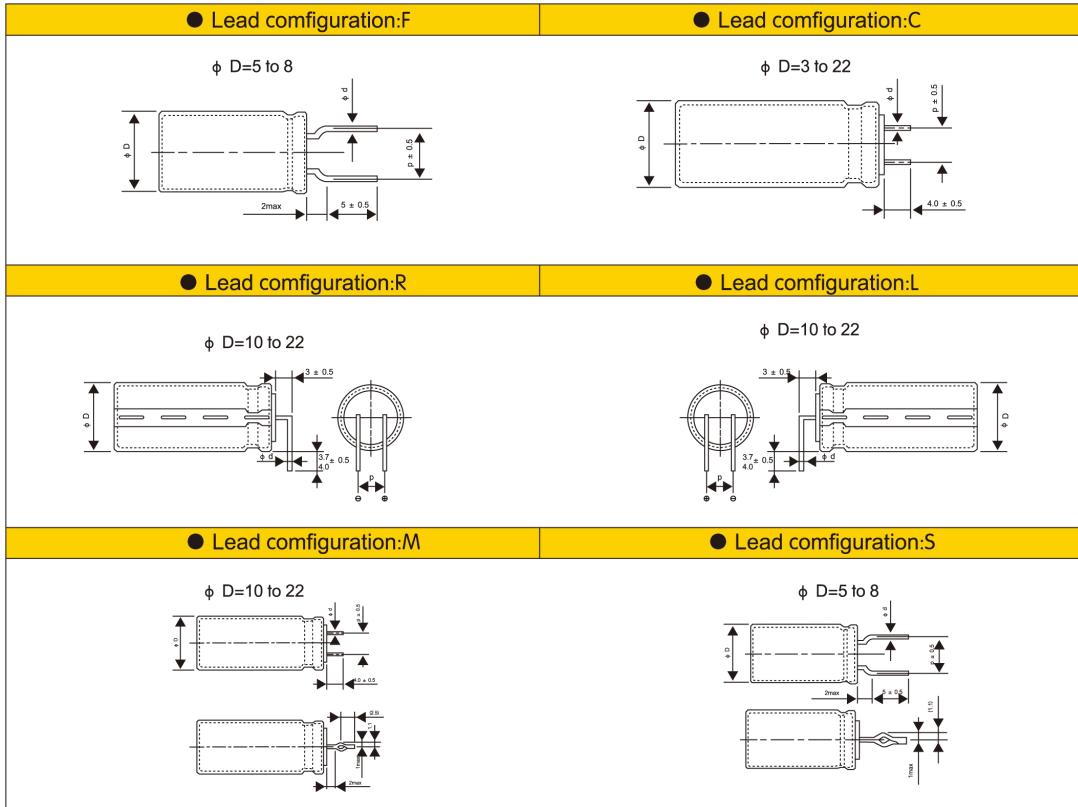

● LEAD SPACING&RECOMMENDED PCB DIMENSIONS

(mm)

Dimension	ϕD	ϕd	p	PC Board		Lead Configuration
				Hole diameter	Thickness	
5	0.5	5.0	0.8	1.6	F C S	
6.3	0.5	5.0	0.8			
8	0.5/0.6	5.0	1.0			
10	0.6	5.0	1.0	1.6	C M R L	
12.5	0.6	5.0	1.0			
16	0.8	7.5	1.2			
18	0.8	7.5	1.2			
20	0.8	7.5	1.2			
22	0.8	10.0	1.2			

● Lead configuration: B

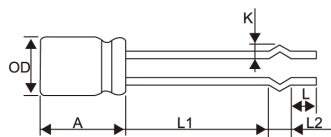

∅D	L1	L2	K	A	L	
5	17.5-19.5	2.6	1.9	10.0-15.0	3.0-5.0	
6.3	17.5-19.5	2.6	1.9	10.0-16.0		
8	12.0-14.0	2.5	1.3	10.0-20.0		
8	13.5-15.5	2.5	1.5			
8	13.0-15.0	3.0	1.5			
8	19.5-21.5	3.0	1.5			
8	21.0-23.0	3.0	1.5			
10	7.5-9.5	2.5	1.7	10.0-25.0		
10	17.0-19.0	2.5	1.7			
10	10.5-12.5	2.5	1.5			
10	10.0-12.0	3.0	1.5			
10	13.0-15.0	3.0	1.5			
10	18.0-20.0	3.0	1.5			
10	21.0-23.0	3.0	1.5			
	± 1.0	± 0.5	0.3	± 1.0		± 1.0

● Lead configuration: K

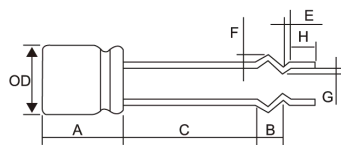

∅D	C	B	E	F	G	A	H
8	13.5-15.5	3	1.2	1.8	0.8	10-20	3.0-5.0
10	18.5-20.5	3	1.2	1.8	1	10-25	
10	19.0-21.0	3	1.5	1.4	0.5		
	± 1.0	± 0.5	± 0.3	± 0.3	± 0.3	± 1.0	± 1.0