

P.C.B LAYOUT
TOP VIEW

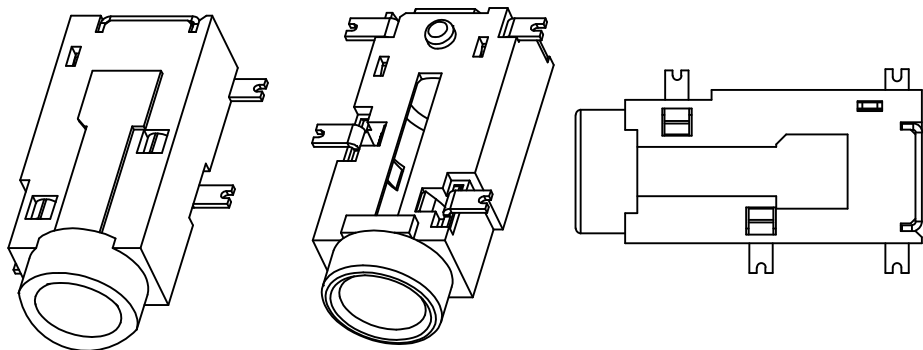
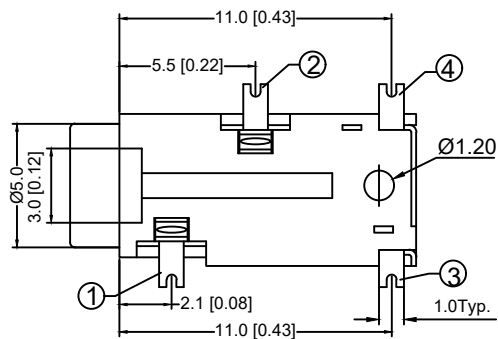
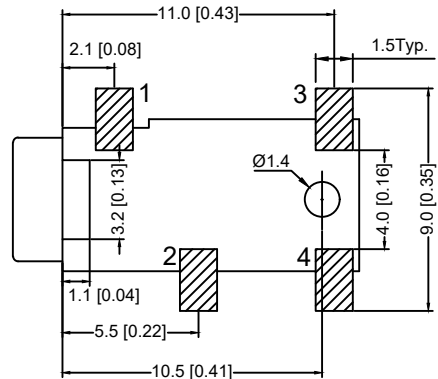

SPECIFICATION

- 1.Rating : DC 30V 0.5A;
- 2.Contact resistance: $\leq 0.03\Omega$;
- 3.Insulation resistance: $\geq 100M\Omega$ (DC250V);
- 4.Withstand voltage: 500VAC ;
- 5.Insertion and extraction force: 3-20N;
- 6.life test: 5,000 cycles.

SCHEMATIC

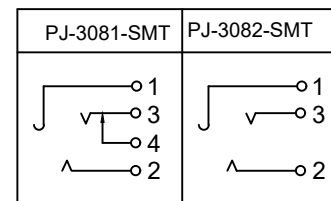

		MATERIAL	PLATING
5	HOUSING	1 PA9T	
4	4# CONTACT FOOT	1 BRASS	Ag-Plating
3	3# CONTACT FOOT	1 BRONZE	Ag-Plating
2	2# CONTACT FOOT	1 BRONZE	Ag-Plating
1	1# CONTACT FOOT	1 BRONZE	Ag-Plating

REVISIONS					UNSPECIFIED TOLERANCES	DSND	DATE	SCALE: N/A	MODEL TYPE: 3.5 PHONE JACK		
ΔX					ANGLAR	±5°	DWN	VIEW:	PART NO.:		
ΔX					X.X	±0.2mm	CHKD	UNIT: mm/in	DWG NO.: PJ-308X-SMT		
ΔX					X.XX	±0.1mm	APPD	SIZE: A4			
MARK	DESCRIPTION	DATE	REVISED	APPROVED	X.XXX	±0.05mm					
www.xk-dg.cn www.helloxkb.com www.helloxkb.cn						XKB INDUSTRIAL PRECISION CO.,LIMITED			WEIGHT 1.0g	SHEET 1/1	REVISION A0