



积层带导线陶瓷电容器

传统产品※

一般等级

FK系列

(※) 新设计时推荐FA、FG系列等支持无卤素品。

Type: 一般 (Up to 50V)
 FK28、FK18
 FK24、FK14
 FK26、FK16
 FK20、FK11
 FK22

 中耐压 (100 to 630V)
 FK28、FK18
 FK24、FK14
 FK26、FK16
 FK20、FK11
 FK22

积层带导线陶瓷电容器 一般等级

RoHS指令对应产品

FK系列 一般(Up to 50V)的概要

特点

- 随着贴片陶瓷电容电介体的薄层化和多层叠层技术的进步，得到更大容量。
- 对于各种环境条件下可确保其有高可靠性。
- 寄生感抗更小，频率响应特性更佳。
- 通过导线上设置扭结的成型加工，在插件时能保持同一高度，焊接时能使气体更容易排放，从而提高焊接的可靠性。
- 也可提供有自动插件用的编带规格，从而可以降低插件成本。

产品名称的识别法

FK 28 C0G 1H 101 J □□□□
(1) (2) (3) (4) (5) (6) (7)

(1) 系列名称

(2) 尺寸·导线形状

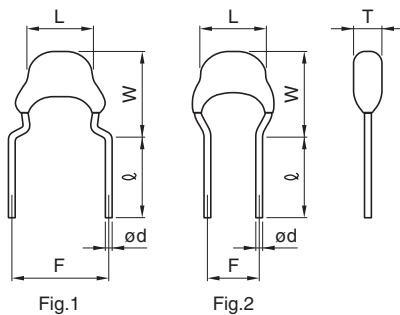

单位: mm

型号	最大L	最大W	最大T	F	l	ød	图
28	4.0	5.5	2.5	5.0±1.0	7±2	0.5+0.1, -0.03	1
24	4.5	5.5	2.5	5.0±1.0	7±2	0.5+0.1, -0.03	1
26	5.5	6.0	3.5	5.0±1.0	7±2	0.5+0.1, -0.03	1
20	5.5	7.0	4.0	5.0±1.0	7±2	0.5+0.1, -0.03	1
22	7.5	8.0	4.0	5.0±1.0	7±2	0.5+0.1, -0.03	1
18	4.0	5.5	2.5	2.5±0.8	5+3, -1	0.5+0.1, -0.03	2
14	4.5	5.5	2.5	2.5±0.8	5+3, -1	0.5+0.1, -0.03	2
16	5.5	6.0	3.5	2.5±0.8	5+3, -1	0.5+0.1, -0.03	2
11	5.5	7.0	4.0	2.5±0.8	5+3, -1	0.5+0.1, -0.03	2

(3) 电容温度特性

种类 1 (温度补偿用)

温度特性	温度系数	温度范围
C0G	0±30ppm/°C	-55 to +125°C

种类 2 (高介电率类)

温度特性	容量变化率	温度范围
X7R	±15%	-55 to +125°C
X5R	±15%	-55 to +85°C
X7S	±22%	-55 to +125°C

(4) 额定电压 E_{dc}

0J	6.3V
1A	10V
1C	16V
1E	25V
1H	50V

(5) 标称电容

以 pF(微微法拉) 为单位, 并用三位数表示。

最初两位数: 有效数字

最后一位数: 接在有效数字后的零数

0R5	0.5pF
010	1pF
100	10pF
102	1,000pF

(6) 电容公差

记号	容差	适用容量范围
C	±0.25pF	10pF以下
D	±0.5pF	
J	±5%	10pF以上
K	±10%	
M	±20%	

(7) 本公司内部管理记号

● RoHS 指令的对应: 表示除了依据 EU Directive 2011/65/EC 免除的用途之外, 未使用铅, 镉, 汞, 六价铬及特定溴系难燃剂 PBB, PBDE 等。

⚠ 为了能够更加正确、安全地使用产品, 请务必索取能进一步确认详细特性、规格的采购规格书。
记载内容可能因为产品改良等原因不经预告而更改, 恕不另行通知。

电容取得范围：种类 1（温度补偿用）

FK28、FK18 型

形状·尺寸

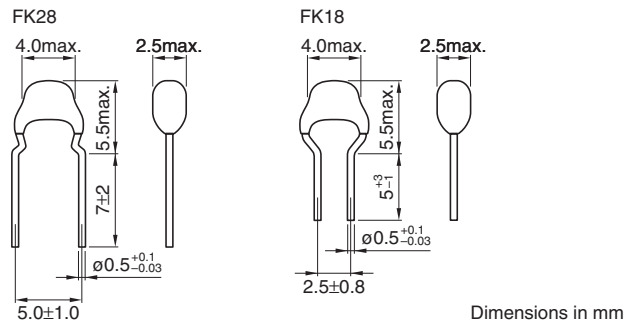

额定电压 Edc: 50V

温度特性	电容	容差	额定电压 E _{dc} (V)	品名	
				FK28 型	FK18 型
C0G	1pF	±0.25pF	50	FK28C0G1H010C	FK18C0G1H010C
C0G	1.5pF	±0.25pF	50	FK28C0G1H1R5C	FK18C0G1H1R5C
C0G	2pF	±0.25pF	50	FK28C0G1H020C	FK18C0G1H020C
C0G	2.2pF	±0.25pF	50	FK28C0G1H2R2C	FK18C0G1H2R2C
C0G	3pF	±0.25pF	50	FK28C0G1H030C	FK18C0G1H030C
C0G	3.3pF	±0.25pF	50	FK28C0G1H3R3C	FK18C0G1H3R3C
C0G	4pF	±0.25pF	50	FK28C0G1H040C	FK18C0G1H040C
C0G	4.7pF	±0.25pF	50	FK28C0G1H4R7C	FK18C0G1H4R7C
C0G	5pF	±0.25pF	50	FK28C0G1H050C	FK18C0G1H050C
C0G	6pF	±0.5pF	50	FK28C0G1H060D	FK18C0G1H060D
C0G	6.8pF	±0.5pF	50	FK28C0G1H6R8D	FK18C0G1H6R8D
C0G	7pF	±0.5pF	50	FK28C0G1H070D	FK18C0G1H070D
C0G	8pF	±0.5pF	50	FK28C0G1H080D	FK18C0G1H080D
C0G	9pF	±0.5pF	50	FK28C0G1H090D	FK18C0G1H090D
C0G	10pF	±0.5pF	50	FK28C0G1H100D	FK18C0G1H100D
C0G	12pF	±5%	50	FK28C0G1H120J	FK18C0G1H120J
C0G	15pF	±5%	50	FK28C0G1H150J	FK18C0G1H150J
C0G	18pF	±5%	50	FK28C0G1H180J	FK18C0G1H180J
C0G	22pF	±5%	50	FK28C0G1H220J	FK18C0G1H220J
C0G	27pF	±5%	50	FK28C0G1H270J	FK18C0G1H270J
C0G	33pF	±5%	50	FK28C0G1H330J	FK18C0G1H330J
C0G	39pF	±5%	50	FK28C0G1H390J	FK18C0G1H390J
C0G	47pF	±5%	50	FK28C0G1H470J	FK18C0G1H470J
C0G	56pF	±5%	50	FK28C0G1H560J	FK18C0G1H560J
C0G	68pF	±5%	50	FK28C0G1H680J	FK18C0G1H680J
C0G	82pF	±5%	50	FK28C0G1H820J	FK18C0G1H820J
C0G	100pF	±5%	50	FK28C0G1H101J	FK18C0G1H101J
C0G	120pF	±5%	50	FK28C0G1H121J	FK18C0G1H121J
C0G	150pF	±5%	50	FK28C0G1H151J	FK18C0G1H151J
C0G	180pF	±5%	50	FK28C0G1H181J	FK18C0G1H181J
C0G	220pF	±5%	50	FK28C0G1H221J	FK18C0G1H221J
C0G	270pF	±5%	50	FK28C0G1H271J	FK18C0G1H271J
C0G	330pF	±5%	50	FK28C0G1H331J	FK18C0G1H331J
C0G	390pF	±5%	50	FK28C0G1H391J	FK18C0G1H391J
C0G	470pF	±5%	50	FK28C0G1H471J	FK18C0G1H471J
C0G	560pF	±5%	50	FK28C0G1H561J	FK18C0G1H561J
C0G	680pF	±5%	50	FK28C0G1H681J	FK18C0G1H681J
C0G	820pF	±5%	50	FK28C0G1H821J	FK18C0G1H821J
C0G	1000pF	±5%	50	FK28C0G1H102J	FK18C0G1H102J
C0G	1200pF	±5%	50	FK28C0G1H122J	FK18C0G1H122J
C0G	1500pF	±5%	50	FK28C0G1H152J	FK18C0G1H152J
C0G	1800pF	±5%	50	FK28C0G1H182J	FK18C0G1H182J
C0G	2200pF	±5%	50	FK28C0G1H222J	FK18C0G1H222J
C0G	2700pF	±5%	50	FK28C0G1H272J	FK18C0G1H272J
C0G	3300pF	±5%	50	FK28C0G1H332J	FK18C0G1H332J
C0G	3900pF	±5%	50	FK28C0G1H392J	FK18C0G1H392J
C0G	4700pF	±5%	50	FK28C0G1H472J	FK18C0G1H472J
C0G	5600pF	±5%	50	FK28C0G1H562J	FK18C0G1H562J
C0G	6800pF	±5%	50	FK28C0G1H682J	FK18C0G1H682J
C0G	8200pF	±5%	50	FK28C0G1H822J	FK18C0G1H822J
C0G	10000pF	±5%	50	FK28C0G1H103J	FK18C0G1H103J

⚠ 为了能够更加正确、安全地使用产品，请务必索取能进一步确认详细特性、规格的采购规格书。
记载内容可能因为产品改良等原因不经预告而更改，恕不另行通知。

FK24、FK14 型

形状・尺寸

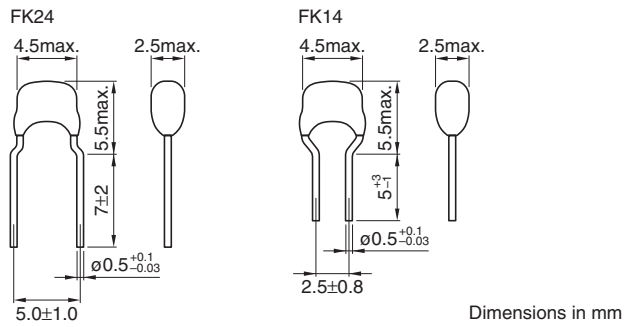

额定电压 Edc: 50V

温度特性	电容	容差	额定电压 E _{dc} (V)	品名	
				FK24 型	FK14 型
C0G	2700pF	±5%	50	FK24C0G1H272J	FK14C0G1H272J
C0G	3300pF	±5%	50	FK24C0G1H332J	FK14C0G1H332J
C0G	3900pF	±5%	50	FK24C0G1H392J	FK14C0G1H392J
C0G	4700pF	±5%	50	FK24C0G1H472J	FK14C0G1H472J
C0G	5600pF	±5%	50	FK24C0G1H562J	FK14C0G1H562J
C0G	6800pF	±5%	50	FK24C0G1H682J	FK14C0G1H682J
C0G	8200pF	±5%	50	FK24C0G1H822J	FK14C0G1H822J
C0G	10000pF	±5%	50	FK24C0G1H103J	FK14C0G1H103J
C0G	15000pF	±5%	50	FK24C0G1H153J	FK14C0G1H153J
C0G	22000pF	±5%	50	FK24C0G1H223J	FK14C0G1H223J
C0G	33000pF	±5%	50	FK24C0G1H333J	FK14C0G1H333J

FK26、FK16 型

形状・尺寸

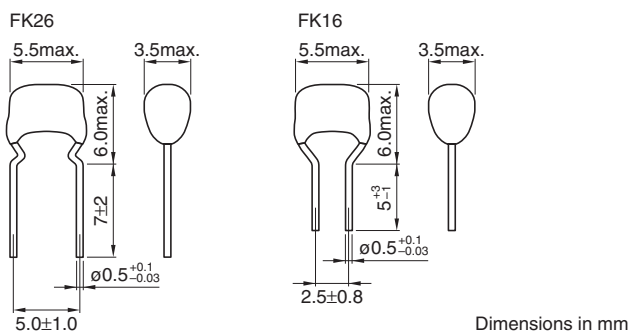

额定电压 Edc: 50V

温度特性	电容	容差	额定电压 E _{dc} (V)	品名	
				FK26 型	FK16 型
C0G	4700pF	±5%	50	FK26C0G1H472J	FK16C0G1H472J
C0G	5600pF	±5%	50	FK26C0G1H562J	FK16C0G1H562J
C0G	6800pF	±5%	50	FK26C0G1H682J	FK16C0G1H682J
C0G	8200pF	±5%	50	FK26C0G1H822J	FK16C0G1H822J
C0G	10000pF	±5%	50	FK26C0G1H103J	FK16C0G1H103J
C0G	15000pF	±5%	50	FK26C0G1H153J	FK16C0G1H153J
C0G	22000pF	±5%	50	FK26C0G1H223J	FK16C0G1H223J
C0G	33000pF	±5%	50	FK26C0G1H333J	FK16C0G1H333J
C0G	47000pF	±5%	50	FK26C0G1H473J	FK16C0G1H473J
C0G	68000pF	±5%	50	FK26C0G1H683J	FK16C0G1H683J
C0G	0.1μF	±5%	50	FK26C0G1H104J	FK16C0G1H104J

FK20、FK11 型

形状·尺寸

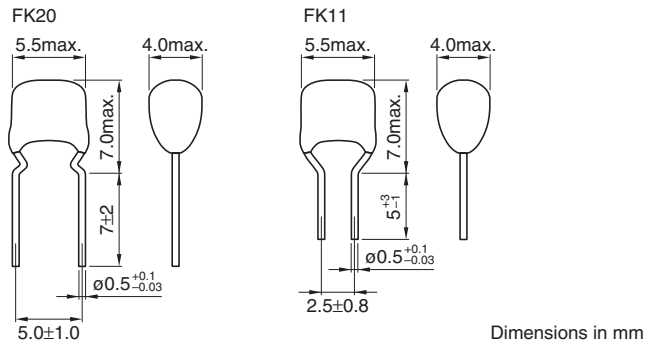

额定电压 Edc: 50V

温度特性	电容	容差	额定电压 E _{dc} (V)	品名	
				FK20 型	FK11 型
C0G	22000pF	±5%	50	FK20C0G1H223J	FK11C0G1H223J
C0G	33000pF	±5%	50	FK20C0G1H333J	FK11C0G1H333J
C0G	47000pF	±5%	50	FK20C0G1H473J	FK11C0G1H473J
C0G	68000pF	±5%	50	FK20C0G1H683J	FK11C0G1H683J
C0G	0.1μF	±5%	50	FK20C0G1H104J	FK11C0G1H104J

FK22 型

形状·尺寸

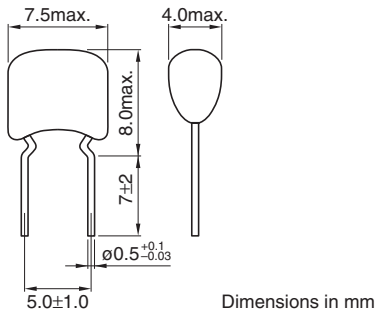

额定电压 Edc: 50V

温度特性	电容	容差	额定电压 E _{dc} (V)	品名	
				FK22 型	
C0G	0.15μF	±5%	50	FK22C0G1H154J	
C0G	0.22μF	±5%	50	FK22C0G1H224J	

电容取得范围：种类 2（高介电率类）

FK28、FK18 型

形状·尺寸

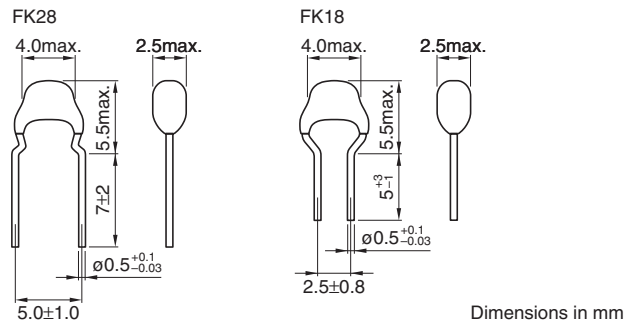

额定电压 Edc: 6.3 to 50V

温度特性	电容	容差	额定电压 E _{dc} (V)	品名	
				FK28 型	FK18 型
X7R	1000pF	±10%	50	FK28X7R1H102K	FK18X7R1H102K
X7R	1500pF	±10%	50	FK28X7R1H152K	FK18X7R1H152K
X7R	2200pF	±10%	50	FK28X7R1H222K	FK18X7R1H222K
X7R	3300pF	±10%	50	FK28X7R1H332K	FK18X7R1H332K
X7R	4700pF	±10%	50	FK28X7R1H472K	FK18X7R1H472K
X7R	6800pF	±10%	50	FK28X7R1H682K	FK18X7R1H682K
X7R	10000pF	±10%	50	FK28X7R1H103K	FK18X7R1H103K
X7R	15000pF	±10%	50	FK28X7R1H153K	FK18X7R1H153K
X7R	22000pF	±10%	50	FK28X7R1H223K	FK18X7R1H223K
X7R	33000pF	±10%	50	FK28X7R1H333K	FK18X7R1H333K
X7R	47000pF	±10%	50	FK28X7R1H473K	FK18X7R1H473K
X7R	68000pF	±10%	50	FK28X7R1H683K	FK18X7R1H683K
X7R	0.1μF	±10%	50	FK28X7R1H104K	FK18X7R1H104K
X7R	0.15μF	±10%	50	FK28X7R1H154K	FK18X7R1H154K
X7R	0.22μF	±10%	50	FK28X7R1H224K	FK18X7R1H224K
X7R	0.1μF	±10%	25	FK28X7R1E104K	FK18X7R1E104K
X7R	0.15μF	±10%	25	FK28X7R1E154K	FK18X7R1E154K
X7R	0.22μF	±10%	25	FK28X7R1E224K	FK18X7R1E224K
X7R	0.33μF	±10%	25	FK28X7R1E334K	FK18X7R1E334K
X7R	0.47μF	±10%	25	FK28X7R1E474K	FK18X7R1E474K
X7R	0.68μF	±10%	25	FK28X7R1E684K	FK18X7R1E684K
X7R	1μF	±10%	25	FK28X7R1E105K	FK18X7R1E105K
X7R	0.22μF	±10%	16	FK28X7R1C224K	FK18X7R1C224K
X7R	0.33μF	±10%	16	FK28X7R1C334K	FK18X7R1C334K
X7R	0.47μF	±10%	16	FK28X7R1C474K	FK18X7R1C474K
X7R	0.68μF	±10%	16	FK28X7R1C684K	FK18X7R1C684K
X7R	1μF	±10%	16	FK28X7R1C105K	FK18X7R1C105K
X7R	1.5μF	±10%	6.3	FK28X7R0J155K	FK18X7R0J155K
X7R	2.2μF	±10%	6.3	FK28X7R0J225K	FK18X7R0J225K
X5R	0.22μF	±10%	25	FK28X5R1E224K	FK18X5R1E224K
X5R	0.33μF	±10%	25	FK28X5R1E334K	FK18X5R1E334K
X5R	0.47μF	±10%	25	FK28X5R1E474K	FK18X5R1E474K
X5R	0.68μF	±10%	25	FK28X5R1E684K	FK18X5R1E684K
X5R	1μF	±10%	25	FK28X5R1E105K	FK18X5R1E105K
X5R	0.47μF	±10%	16	FK28X5R1C474K	FK18X5R1C474K
X5R	0.68μF	±10%	16	FK28X5R1C684K	FK18X5R1C684K
X5R	1μF	±10%	16	FK28X5R1C105K	FK18X5R1C105K
X5R	1.5μF	±10%	16	FK28X5R1C155K	FK18X5R1C155K
X5R	2.2μF	±10%	16	FK28X5R1C225K	FK18X5R1C225K
X5R	0.33μF	±10%	10	FK28X5R1A334K	FK18X5R1A334K
X5R	0.47μF	±10%	10	FK28X5R1A474K	FK18X5R1A474K
X5R	0.68μF	±10%	10	FK28X5R1A684K	FK18X5R1A684K
X5R	1μF	±10%	10	FK28X5R1A105K	FK18X5R1A105K
X5R	1.5μF	±10%	10	FK28X5R1A155K	FK18X5R1A155K
X5R	2.2μF	±10%	10	FK28X5R1A225K	FK18X5R1A225K
X5R	3.3μF	±10%	10	FK28X5R1A335K	FK18X5R1A335K
X5R	4.7μF	±10%	10	FK28X5R1A475K	FK18X5R1A475K

⚠ 为了能够更加正确、安全地使用产品，请务必索取能进一步确认详细特性、规格的采购规格书。
记载内容可能因为产品改良等原因不经预告而更改，恕不另行通知。

额定电压 Edc: 6.3 to 50V

温度特性	电容	容差	额定电压 E _{dc} (V)	品名	
				FK28 型	FK18 型
X5R	1 μ F	$\pm 10\%$	6.3	FK28X5R0J105K	FK18X5R0J105K
X5R	1.5 μ F	$\pm 10\%$	6.3	FK28X5R0J155K	FK18X5R0J155K
X5R	2.2 μ F	$\pm 10\%$	6.3	FK28X5R0J225K	FK18X5R0J225K
X5R	3.3 μ F	$\pm 10\%$	6.3	FK28X5R0J335K	FK18X5R0J335K
X5R	4.7 μ F	$\pm 10\%$	6.3	FK28X5R0J475K	FK18X5R0J475K
X5R	6.8 μ F	$\pm 10\%$	6.3	FK28X5R0J685K	FK18X5R0J685K
X5R	10 μ F	$\pm 20\%$	6.3	FK28X5R0J106M	FK18X5R0J106M

FK24、FK14 型

形状・尺寸

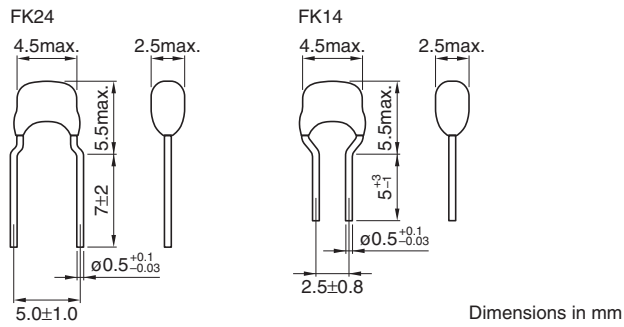

额定电压 Edc: 6.3 to 50V

温度特性	电容	容差	额定电压 Edc(V)	品名	
				FK24 型	FK14 型
X7R	0.15 μ F	$\pm 10\%$	50	FK24X7R1H154K	FK14X7R1H154K
X7R	0.22 μ F	$\pm 10\%$	50	FK24X7R1H224K	FK14X7R1H224K
X7R	0.33 μ F	$\pm 10\%$	50	FK24X7R1H334K	FK14X7R1H334K
X7R	0.47 μ F	$\pm 10\%$	50	FK24X7R1H474K	FK14X7R1H474K
X7R	0.68 μ F	$\pm 10\%$	50	FK24X7R1H684K	FK14X7R1H684K
X7R	1 μ F	$\pm 10\%$	50	FK24X7R1H105K	FK14X7R1H105K
X7R	0.47 μ F	$\pm 10\%$	25	FK24X7R1E474K	FK14X7R1E474K
X7R	0.68 μ F	$\pm 10\%$	25	FK24X7R1E684K	FK14X7R1E684K
X7R	1 μ F	$\pm 10\%$	25	FK24X7R1E105K	FK14X7R1E105K
X7R	1.5 μ F	$\pm 10\%$	25	FK24X7R1E155K	FK14X7R1E155K
X7R	2.2 μ F	$\pm 10\%$	25	FK24X7R1E225K	FK14X7R1E225K
X7R	3.3 μ F	$\pm 10\%$	25	FK24X7R1E335K	FK14X7R1E335K
X7R	4.7 μ F	$\pm 10\%$	25	FK24X7R1E475K	FK14X7R1E475K
X7R	0.68 μ F	$\pm 10\%$	16	FK24X7R1C684K	FK14X7R1C684K
X7R	1 μ F	$\pm 10\%$	16	FK24X7R1C105K	FK14X7R1C105K
X7R	1.5 μ F	$\pm 10\%$	16	FK24X7R1C155K	FK14X7R1C155K
X7R	2.2 μ F	$\pm 10\%$	16	FK24X7R1C225K	FK14X7R1C225K
X7R	3.3 μ F	$\pm 10\%$	16	FK24X7R1C335K	FK14X7R1C335K
X7R	4.7 μ F	$\pm 10\%$	16	FK24X7R1C475K	FK14X7R1C475K
X7R	6.8 μ F	$\pm 10\%$	6.3	FK24X7R0J685K	FK14X7R0J685K
X7R	10 μ F	$\pm 10\%$	6.3	FK24X7R0J106K	FK14X7R0J106K
X5R	0.68 μ F	$\pm 10\%$	25	FK24X5R1E684K	FK14X5R1E684K
X5R	1 μ F	$\pm 10\%$	25	FK24X5R1E105K	FK14X5R1E105K
X5R	1.5 μ F	$\pm 10\%$	25	FK24X5R1E155K	FK14X5R1E155K
X5R	2.2 μ F	$\pm 10\%$	25	FK24X5R1E225K	FK14X5R1E225K
X5R	3.3 μ F	$\pm 10\%$	25	FK24X5R1E335K	FK14X5R1E335K
X5R	4.7 μ F	$\pm 10\%$	25	FK24X5R1E475K	FK14X5R1E475K
X5R	1 μ F	$\pm 10\%$	16	FK24X5R1C105K	FK14X5R1C105K
X5R	1.5 μ F	$\pm 10\%$	16	FK24X5R1C155K	FK14X5R1C155K
X5R	2.2 μ F	$\pm 10\%$	16	FK24X5R1C225K	FK14X5R1C225K
X5R	3.3 μ F	$\pm 10\%$	16	FK24X5R1C335K	FK14X5R1C335K
X5R	4.7 μ F	$\pm 10\%$	16	FK24X5R1C475K	FK14X5R1C475K
X5R	10 μ F	$\pm 10\%$	16	FK24X5R1C106K	FK14X5R1C106K
X5R	1.5 μ F	$\pm 10\%$	10	FK24X5R1A155K	FK14X5R1A155K
X5R	2.2 μ F	$\pm 10\%$	10	FK24X5R1A225K	FK14X5R1A225K
X5R	3.3 μ F	$\pm 10\%$	10	FK24X5R1A335K	FK14X5R1A335K
X5R	4.7 μ F	$\pm 10\%$	10	FK24X5R1A475K	FK14X5R1A475K
X5R	6.8 μ F	$\pm 10\%$	10	FK24X5R1A685K	FK14X5R1A685K
X5R	10 μ F	$\pm 10\%$	10	FK24X5R1A106K	FK14X5R1A106K
X5R	4.7 μ F	$\pm 10\%$	6.3	FK24X5R0J475K	FK14X5R0J475K
X5R	6.8 μ F	$\pm 10\%$	6.3	FK24X5R0J685K	FK14X5R0J685K
X5R	10 μ F	$\pm 10\%$	6.3	FK24X5R0J106K	FK14X5R0J106K
X5R	15 μ F	$\pm 20\%$	6.3	FK24X5R0J156M	FK14X5R0J156M
X5R	22 μ F	$\pm 20\%$	6.3	FK24X5R0J226M	FK14X5R0J226M

⚠ 为了能够更加正确、安全地使用产品，请务必索取能进一步确认详细特性、规格的采购规格书。
记载内容可能因为产品改良等原因不经预告而更改，恕不另行通知。

FK26、FK16 型

形状・尺寸

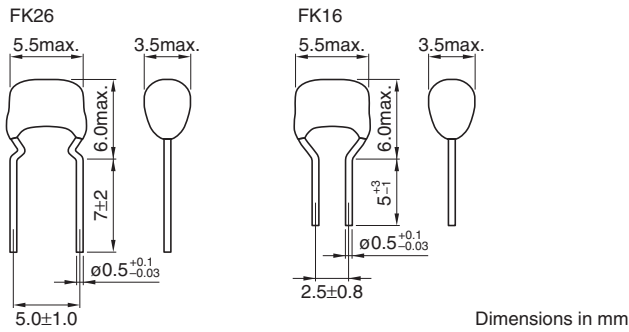

额定电压 Edc: 6.3 to 50V

温度特性	电容	容差	额定电压 E _{dc} (V)	品名	
				FK26 型	FK16 型
X7R	0.47 μ F	$\pm 10\%$	50	FK26X7R1H474K	FK16X7R1H474K
X7R	0.68 μ F	$\pm 10\%$	50	FK26X7R1H684K	FK16X7R1H684K
X7R	1 μ F	$\pm 10\%$	50	FK26X7R1H105K	FK16X7R1H105K
X7R	1.5 μ F	$\pm 10\%$	50	FK26X7R1H155K	FK16X7R1H155K
X7R	2.2 μ F	$\pm 10\%$	50	FK26X7R1H225K	FK16X7R1H225K
X7R	0.68 μ F	$\pm 10\%$	25	FK26X7R1E684K	FK16X7R1E684K
X7R	1 μ F	$\pm 10\%$	25	FK26X7R1E105K	FK16X7R1E105K
X7R	1.5 μ F	$\pm 10\%$	25	FK26X7R1E155K	FK16X7R1E155K
X7R	2.2 μ F	$\pm 10\%$	25	FK26X7R1E225K	FK16X7R1E225K
X7R	3.3 μ F	$\pm 10\%$	25	FK26X7R1E335K	FK16X7R1E335K
X7R	4.7 μ F	$\pm 10\%$	25	FK26X7R1E475K	FK16X7R1E475K
X7R	6.8 μ F	$\pm 10\%$	25	FK26X7R1E685K	FK16X7R1E685K
X7R	10 μ F	$\pm 10\%$	25	FK26X7R1E106K	FK16X7R1E106K
X7R	3.3 μ F	$\pm 10\%$	16	FK26X7R1C335K	FK16X7R1C335K
X7R	4.7 μ F	$\pm 10\%$	16	FK26X7R1C475K	FK16X7R1C475K
X7R	6.8 μ F	$\pm 10\%$	16	FK26X7R1C685K	FK16X7R1C685K
X7R	10 μ F	$\pm 10\%$	16	FK26X7R1C106K	FK16X7R1C106K
X5R	1 μ F	$\pm 10\%$	50	FK26X5R1H105K	FK16X5R1H105K
X5R	1.5 μ F	$\pm 10\%$	25	FK26X5R1E155K	FK16X5R1E155K
X5R	2.2 μ F	$\pm 10\%$	25	FK26X5R1E225K	FK16X5R1E225K
X5R	3.3 μ F	$\pm 10\%$	25	FK26X5R1E335K	FK16X5R1E335K
X5R	4.7 μ F	$\pm 10\%$	25	FK26X5R1E475K	FK16X5R1E475K
X5R	3.3 μ F	$\pm 10\%$	16	FK26X5R1C335K	FK16X5R1C335K
X5R	4.7 μ F	$\pm 10\%$	16	FK26X5R1C475K	FK16X5R1C475K
X5R	6.8 μ F	$\pm 10\%$	16	FK26X5R1C685K	FK16X5R1C685K
X5R	10 μ F	$\pm 10\%$	16	FK26X5R1C106K	FK16X5R1C106K
X5R	6.8 μ F	$\pm 10\%$	10	FK26X5R1A685K	FK16X5R1A685K
X5R	10 μ F	$\pm 10\%$	10	FK26X5R1A106K	FK16X5R1A106K
X5R	6.8 μ F	$\pm 10\%$	6.3	FK26X5R0J685K	FK16X5R0J685K
X5R	10 μ F	$\pm 10\%$	6.3	FK26X5R0J106K	FK16X5R0J106K
X5R	15 μ F	$\pm 20\%$	6.3	FK26X5R0J156M	FK16X5R0J156M
X5R	22 μ F	$\pm 20\%$	6.3	FK26X5R0J226M	FK16X5R0J226M
X5R	33 μ F	$\pm 20\%$	6.3	FK26X5R0J336M	FK16X5R0J336M
X5R	47 μ F	$\pm 20\%$	6.3	FK26X5R0J476M	FK16X5R0J476M

⚠ 为了能够更加正确、安全地使用产品，请务必索取能进一步确认详细特性、规格的采购规格书。
记载内容可能因为产品改良等原因不经预告而更改，恕不另行通知。

FK20、FK11 型

形状・尺寸

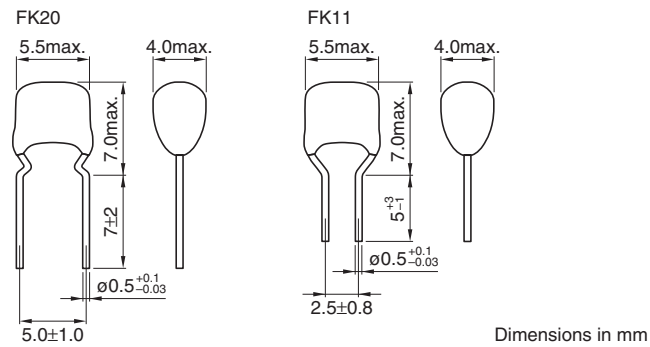

额定电压 Edc: 6.3 to 50V

温度特性	电容	容差	额定电压 E _{dc} (V)	品名	
				FK20 型	FK11 型
X7R	0.68μF	±10%	50	FK20X7R1H684K	FK11X7R1H684K
X7R	1μF	±10%	50	FK20X7R1H105K	FK11X7R1H105K
X7R	1.5μF	±10%	50	FK20X7R1H155K	FK11X7R1H155K
X7R	2.2μF	±10%	50	FK20X7R1H225K	FK11X7R1H225K
X7R	3.3μF	±10%	50	FK20X7R1H335K	FK11X7R1H335K
X7R	4.7μF	±10%	50	FK20X7R1H475K	FK11X7R1H475K
X7R	2.2μF	±10%	25	FK20X7R1E225K	FK11X7R1E225K
X7R	3.3μF	±10%	25	FK20X7R1E335K	FK11X7R1E335K
X7R	4.7μF	±10%	25	FK20X7R1E475K	FK11X7R1E475K
X7R	6.8μF	±10%	25	FK20X7R1E685K	FK11X7R1E685K
X7R	10μF	±10%	25	FK20X7R1E106K	FK11X7R1E106K
X7R	10μF	±10%	16	FK20X7R1C106K	FK11X7R1C106K
X7R	15μF	±20%	16	FK20X7R1C156M	FK11X7R1C156M
X7R	22μF	±20%	16	FK20X7R1C226M	FK11X7R1C226M
X7R	22μF	±20%	10	FK20X7R1A226M	FK11X7R1A226M
X5R	2.2μF	±10%	50	FK20X5R1H225K	FK11X5R1H225K
X5R	3.3μF	±10%	50	FK20X5R1H335K	FK11X5R1H335K
X5R	4.7μF	±10%	25	FK20X5R1E475K	FK11X5R1E475K
X5R	6.8μF	±10%	25	FK20X5R1E685K	FK11X5R1E685K
X5R	10μF	±10%	25	FK20X5R1E106K	FK11X5R1E106K
X5R	10μF	±10%	16	FK20X5R1C106K	FK11X5R1C106K
X5R	15μF	±20%	16	FK20X5R1C156M	FK11X5R1C156M
X5R	22μF	±20%	16	FK20X5R1C226M	FK11X5R1C226M
X5R	15μF	±20%	10	FK20X5R1A156M	FK11X5R1A156M
X5R	22μF	±20%	10	FK20X5R1A226M	FK11X5R1A226M
X5R	22μF	±20%	6.3	FK20X5R0J226M	FK11X5R0J226M
X5R	33μF	±20%	6.3	FK20X5R0J336M	FK11X5R0J336M
X5R	47μF	±20%	6.3	FK20X5R0J476M	FK11X5R0J476M
X5R	68μF	±20%	6.3	FK20X5R0J686M	FK11X5R0J686M
X5R	100μF	±20%	6.3	FK20X5R0J107M	FK11X5R0J107M
X7S	4.7μF	±10%	50	FK20X7S1H475K	FK11X7S1H475K
X7S	6.8μF	±10%	50	FK20X7S1H685K	FK11X7S1H685K
X7S	10μF	±10%	50	FK20X7S1H106K	FK11X7S1H106K

⚠ 为了能够更加正确、安全地使用产品，请务必索取能进一步确认详细特性、规格的采购规格书。
记载内容可能因为产品改良等原因不经预告而更改，恕不另行通知。

FK22 型

形状·尺寸

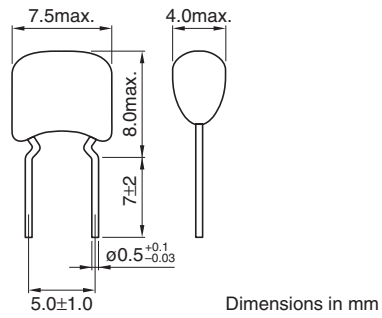

额定电压 Edc: 6.3 to 50V

温度特性	电容	容差	额定电压 E _{dc} (V)	品名 FK22 型
X7R	1.5μF	±10%	50	FK22X7R1H155K
X7R	2.2μF	±10%	50	FK22X7R1H225K
X7R	3.3μF	±10%	50	FK22X7R1H335K
X7R	4.7μF	±10%	50	FK22X7R1H475K
X7R	6.8μF	±10%	50	FK22X7R1H685K
X7R	4.7μF	±10%	25	FK22X7R1E475K
X7R	6.8μF	±10%	25	FK22X7R1E685K
X7R	10μF	±10%	25	FK22X7R1E106K
X7R	15μF	±20%	25	FK22X7R1E156M
X7R	22μF	±20%	25	FK22X7R1E226M
X7R	15μF	±20%	16	FK22X7R1C156M
X7R	22μF	±20%	16	FK22X7R1C226M
X7R	33μF	±20%	16	FK22X7R1C336M
X5R	4.7μF	±10%	50	FK22X5R1H475K
X5R	6.8μF	±10%	50	FK22X5R1H685K
X5R	15μF	±20%	25	FK22X5R1E156M
X5R	22μF	±20%	25	FK22X5R1E226M
X5R	33μF	±20%	16	FK22X5R1C336M
X5R	33μF	±20%	10	FK22X5R1A336M
X5R	47μF	±20%	10	FK22X5R1A476M
X5R	68μF	±20%	6.3	FK22X5R0J686M
X5R	100μF	±20%	6.3	FK22X5R0J107M

●要了解没有记载的电容量及产品说明，请向本公司询问。

 为了能够更加正确、安全地使用产品，请务必索取能进一步确认详细特性、规格的采购规格书。
记载内容可能因为产品改良等原因不经预告而更改，恕不另行通知。

包装形式

卷带尺寸

FK1 系列

(FK18、FK14、FK16、FK11 型)

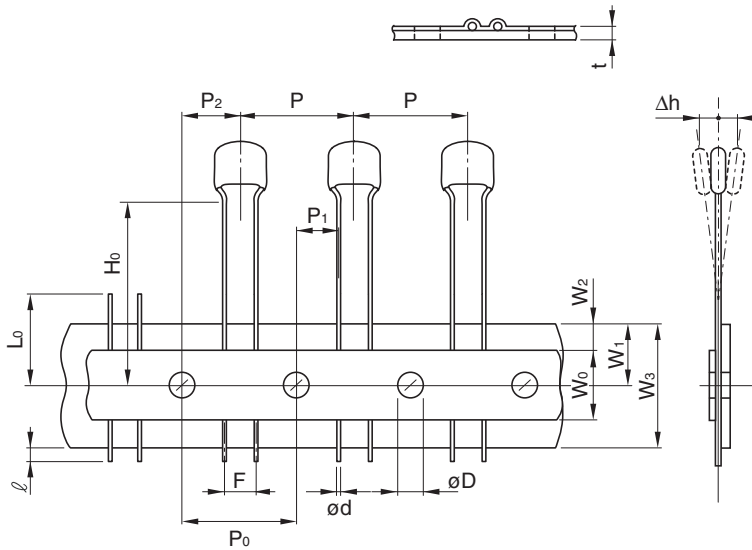

记号	尺寸(mm)
P	12.7±1.0
P ₀ *1	12.7±0.3
P ₁	5.1±0.7
P ₂	6.35±1.3
W ₀	12.0±1.0
W ₁	9.0±0.5
W ₂ *2	3.0max.
W ₃	18.0+1.0, -0.5
H ₀	16.0±0.5
ℓ	1.0max.
t	0.6±0.2
L ₀ *3	11.0max.
F	2.5+0.5, -0.2
ød	ø0.5+0.1, -0.03
øD	ø4.0±0.2
Δh	0±2

*1 20个间距时的累积间距偏差为±2mm。

*2 粘贴胶带不得超出台纸。

*3 连续未穿入孔的产品不超过3个。

FK2 系列

(FK28、FK24、FK26、FK20、FK22 型)

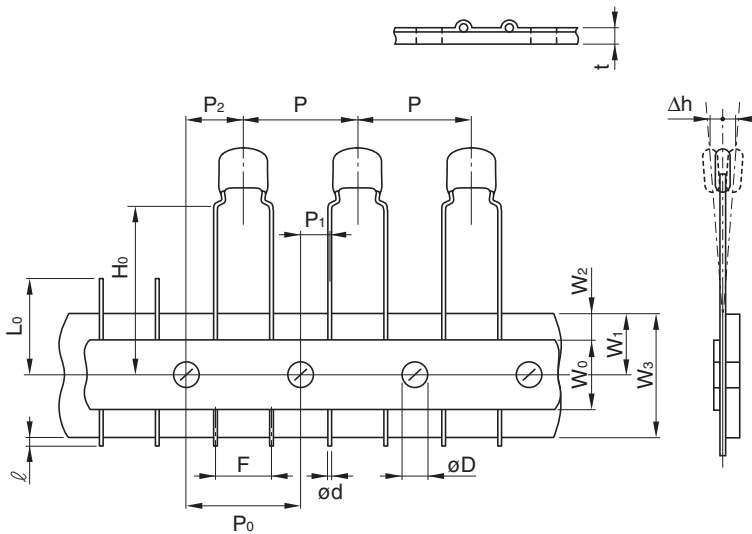

记号	尺寸(mm)
P	12.7±1.0
P ₀ *1	12.7±0.3
P ₁	3.85±0.7
P ₂	6.35±1.3
W ₀	12.0±1.0
W ₁	9.0±0.5
W ₂ *2	3.0max.
W ₃	18.0+1.0, -0.5
H ₀	16.0±0.5
ℓ	1.0max.
t	0.6±0.2
L ₀ *3	11.0max.
F	5.0+0.8, -0.2
ød	ø0.5+0.1, -0.03
øD	ø4.0±0.2
Δh	0±2

*1 20个间距时的累积间距偏差为±2mm。

*2 粘贴胶带不得超出台纸。

*3 连续未穿入孔的产品不超过3个。

包装个数

型名	个数
FK28、FK18	
FK24、FK14	2000个/1箱
FK26、FK16	
FK20、FK11	1500个/1箱
FK22	

⚠ 为了能够更加正确、安全地使用产品，请务必索取能进一步确认详细特性、规格的采购规格书。
 记载内容可能因为产品改良等原因不经预告而更改，恕不另行通知。

积层带导线陶瓷电容器 一般等级

RoHS指令对应产品

FK系列 中耐压(100 to 630V)的概要

特点

- 针对高电压的独特设计结构，体积小而具有高耐压的特性。
- 额定电压Edc: 可适应100, 250, 630V。
- 通过导线上设置扭结的成型加工，在插件时能保持同一高度，焊接时能使气体更容易排放，从而提高焊接的可靠性。
- 也可提供有自动插件用的编带规格，从而可以降低插件成本。

产品名称的识别法

FK 28 X7R 2A 102 K □□□□
(1) (2) (3) (4) (5) (6) (7)

(1) 系列名称

(2) 尺寸·导线形状

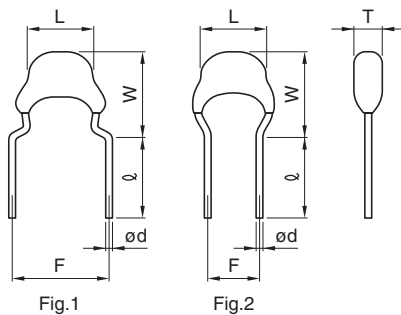

型号	最大 L	最大 W	最大 T	F	l	ød	图
28	4.0	5.5	2.5	5.0±1.0	7±2	0.5+0.1, -0.03	1
24	4.5	5.5	2.5	5.0±1.0	7±2	0.5+0.1, -0.03	1
26	5.5	6.0	3.5	5.0±1.0	7±2	0.5+0.1, -0.03	1
20	5.5	7.0	4.0	5.0±1.0	7±2	0.5+0.1, -0.03	1
22	7.5	8.0	4.0	5.0±1.0	7±2	0.5+0.1, -0.03	1
18	4.0	5.5	2.5	2.5±0.8	5+3, -1	0.5+0.1, -0.03	2
14	4.5	5.5	2.5	2.5±0.8	5+3, -1	0.5+0.1, -0.03	2
16	5.5	6.0	3.5	2.5±0.8	5+3, -1	0.5+0.1, -0.03	2
11	5.5	7.0	4.0	2.5±0.8	5+3, -1	0.5+0.1, -0.03	2

单位: mm

(4) 额定电压 Edc

2A	100V
2E	250V
2J	630V

(5) 标称电容

以 pF(微微法拉) 为单位，并用三位数表示。

最初两位数：有效数字

最后一位数：接在有效数字后的零数

102	1,000pF
333	33,000pF
474	470,000pF

(6) 电容公差

记号	容差
J	±5%
K	±10%

(7) 本公司内部管理记号

(3) 电容温度特性

种类 1 (温度补偿用)

温度特性	温度系数	温度范围
C0G	0±30ppm/°C	-55 to +125°C

种类 2 (高介电率类)

温度特性	容量变化率	温度范围
X7R	±15%	-55 to +125°C
X7S	±22%	-55 to +125°C

● RoHS 指令的对应：表示除了依据 EU Directive 2011/65/EC 免除的用途之外，未使用铅，镉，汞，六价铬及特定溴系难燃剂 PBB，PBDE 等。

⚠ 为了能够更加正确、安全地使用产品，请务必索取能进一步确认详细特性、规格的采购规格书。
记载内容可能因为产品改良等原因不经预告而更改，恕不另行通知。

电容取得范围：种类 1（温度补偿用）

FK28、FK18 型

形状・尺寸

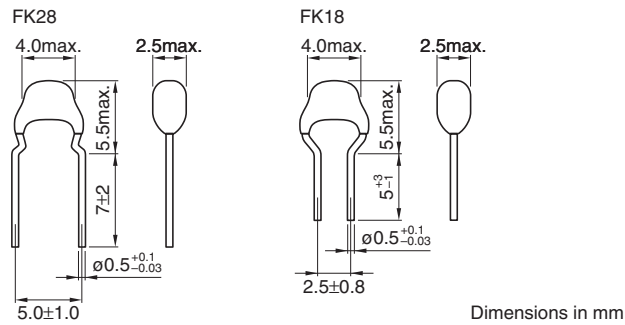

额定电压 Edc: 100 to 250V

温度特性	电容	容差	额定电压 E _{dc} (V)	品名	
				FK28 型	FK18 型
C0G	100pF	±5%	100	FK28C0G2A101J	FK18C0G2A101J
C0G	120pF	±5%	100	FK28C0G2A121J	FK18C0G2A121J
C0G	150pF	±5%	100	FK28C0G2A151J	FK18C0G2A151J
C0G	180pF	±5%	100	FK28C0G2A181J	FK18C0G2A181J
C0G	220pF	±5%	100	FK28C0G2A221J	FK18C0G2A221J
C0G	270pF	±5%	100	FK28C0G2A271J	FK18C0G2A271J
C0G	330pF	±5%	100	FK28C0G2A331J	FK18C0G2A331J
C0G	390pF	±5%	100	FK28C0G2A391J	FK18C0G2A391J
C0G	470pF	±5%	100	FK28C0G2A471J	FK18C0G2A471J
C0G	560pF	±5%	100	FK28C0G2A561J	FK18C0G2A561J
C0G	680pF	±5%	100	FK28C0G2A681J	FK18C0G2A681J
C0G	820pF	±5%	100	FK28C0G2A821J	FK18C0G2A821J
C0G	1000pF	±5%	100	FK28C0G2A102J	FK18C0G2A102J
C0G	1200pF	±5%	100	FK28C0G2A122J	FK18C0G2A122J
C0G	100pF	±5%	250	FK28C0G2E101J	FK18C0G2E101J
C0G	120pF	±5%	250	FK28C0G2E121J	FK18C0G2E121J
C0G	150pF	±5%	250	FK28C0G2E151J	FK18C0G2E151J
C0G	180pF	±5%	250	FK28C0G2E181J	FK18C0G2E181J
C0G	220pF	±5%	250	FK28C0G2E221J	FK18C0G2E221J
C0G	270pF	±5%	250	FK28C0G2E271J	FK18C0G2E271J
C0G	330pF	±5%	250	FK28C0G2E331J	FK18C0G2E331J
C0G	390pF	±5%	250	FK28C0G2E391J	FK18C0G2E391J
C0G	470pF	±5%	250	FK28C0G2E471J	FK18C0G2E471J
C0G	560pF	±5%	250	FK28C0G2E561J	FK18C0G2E561J
C0G	680pF	±5%	250	FK28C0G2E681J	FK18C0G2E681J

⚠ 为了能够更加正确、安全地使用产品，请务必索取能进一步确认详细特性、规格的采购规格书。
记载内容可能因为产品改良等原因不经预告而更改，恕不另行通知。

FK24、FK14 型

形状・尺寸

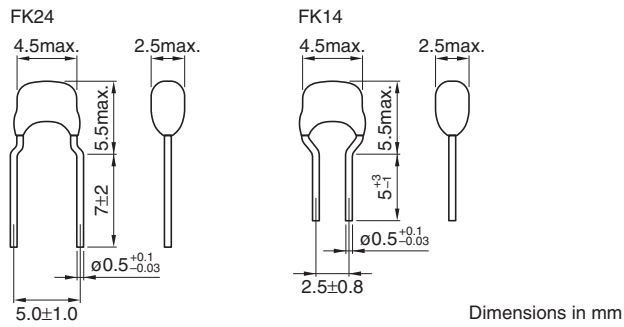

额定电压 Edc: 100 to 250V

温度特性	电容	容差	额定电压 E _{dc} (V)	品名	
				FK24 型	FK14 型
C0G	1000pF	±5%	100	FK24C0G2A102J	FK14C0G2A102J
C0G	1200pF	±5%	100	FK24C0G2A122J	FK14C0G2A122J
C0G	1500pF	±5%	100	FK24C0G2A152J	FK14C0G2A152J
C0G	1800pF	±5%	100	FK24C0G2A182J	FK14C0G2A182J
C0G	2200pF	±5%	100	FK24C0G2A222J	FK14C0G2A222J
C0G	2700pF	±5%	100	FK24C0G2A272J	FK14C0G2A272J
C0G	3300pF	±5%	100	FK24C0G2A332J	FK14C0G2A332J
C0G	3900pF	±5%	100	FK24C0G2A392J	FK14C0G2A392J
C0G	4700pF	±5%	100	FK24C0G2A472J	FK14C0G2A472J
C0G	820pF	±5%	250	FK24C0G2E821J	FK14C0G2E821J
C0G	1000pF	±5%	250	FK24C0G2E102J	FK14C0G2E102J
C0G	1200pF	±5%	250	FK24C0G2E122J	FK14C0G2E122J
C0G	1500pF	±5%	250	FK24C0G2E152J	FK14C0G2E152J
C0G	1800pF	±5%	250	FK24C0G2E182J	FK14C0G2E182J
C0G	2200pF	±5%	250	FK24C0G2E222J	FK14C0G2E222J
C0G	2700pF	±5%	250	FK24C0G2E272J	FK14C0G2E272J

⚠ 为了能够更加正确、安全地使用产品，请务必索取能进一步确认详细特性、规格的采购规格书。
 记载内容可能因为产品改良等原因不经预告而更改，恕不另行通知。

FK26、FK16 型

形状・尺寸

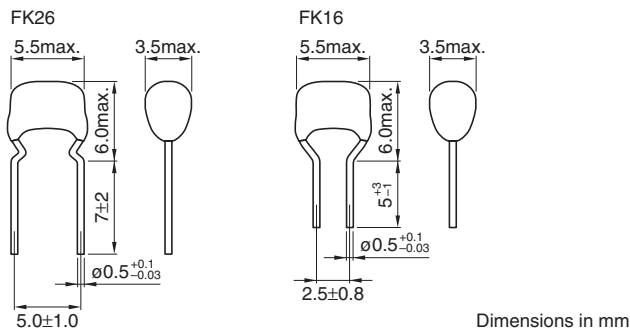

额定电压 Edc: 100 to 630V

温度特性	电容	容差	额定电压 Edc(V)	品名	
				FK26 型	FK16 型
C0G	3900pF	±5%	100	FK26C0G2A392J	FK16C0G2A392J
C0G	4700pF	±5%	100	FK26C0G2A472J	FK16C0G2A472J
C0G	5600pF	±5%	100	FK26C0G2A562J	FK16C0G2A562J
C0G	6800pF	±5%	100	FK26C0G2A682J	FK16C0G2A682J
C0G	8200pF	±5%	100	FK26C0G2A822J	FK16C0G2A822J
C0G	10000pF	±5%	100	FK26C0G2A103J	FK16C0G2A103J
C0G	3300pF	±5%	250	FK26C0G2E332J	
C0G	3900pF	±5%	250	FK26C0G2E392J	
C0G	4700pF	±5%	250	FK26C0G2E472J	
C0G	5600pF	±5%	250	FK26C0G2E562J	
C0G	6800pF	±5%	250	FK26C0G2E682J	
C0G	8200pF	±5%	250	FK26C0G2E822J	
C0G	100pF	±5%	630	FK26C0G2J101J	
C0G	120pF	±5%	630	FK26C0G2J121J	
C0G	150pF	±5%	630	FK26C0G2J151J	
C0G	180pF	±5%	630	FK26C0G2J181J	
C0G	220pF	±5%	630	FK26C0G2J221J	
C0G	270pF	±5%	630	FK26C0G2J271J	
C0G	330pF	±5%	630	FK26C0G2J331J	
C0G	390pF	±5%	630	FK26C0G2J391J	
C0G	470pF	±5%	630	FK26C0G2J471J	
C0G	560pF	±5%	630	FK26C0G2J561J	
C0G	680pF	±5%	630	FK26C0G2J681J	
C0G	820pF	±5%	630	FK26C0G2J821J	
C0G	1000pF	±5%	630	FK26C0G2J102J	
C0G	1200pF	±5%	630	FK26C0G2J122J	
C0G	1500pF	±5%	630	FK26C0G2J152J	
C0G	1800pF	±5%	630	FK26C0G2J182J	
C0G	2200pF	±5%	630	FK26C0G2J222J	
C0G	2700pF	±5%	630	FK26C0G2J272J	
C0G	3300pF	±5%	630	FK26C0G2J332J	

FK20、FK11 型

形状・尺寸

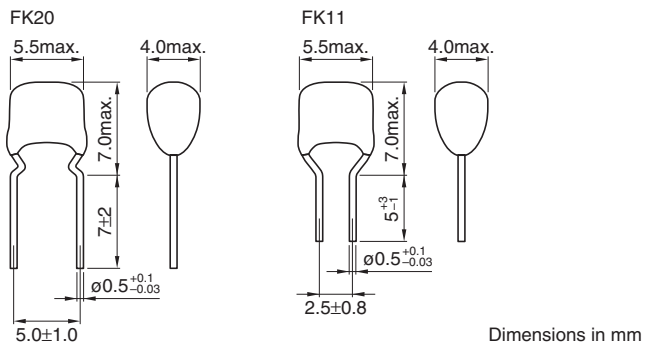

Dimensions in mm

额定电压 Edc: 100 to 630V

温度特性	电容	容差	额定电压 E _{dc} (V)	品名	
				FK20 型	FK11 型
C0G	1500pF	±5%	100	FK20C0G2A153J	FK11C0G2A153J
C0G	2200pF	±5%	100	FK20C0G2A223J	FK11C0G2A223J
C0G	3300pF	±5%	100	FK20C0G2A333J	FK11C0G2A333J
C0G	4700pF	±5%	100	FK20C0G2A473J	FK11C0G2A473J
C0G	1000pF	±5%	250	FK20C0G2E103J	
C0G	1500pF	±5%	250	FK20C0G2E153J	
C0G	390pF	±5%	630	FK20C0G2J392J	
C0G	470pF	±5%	630	FK20C0G2J472J	
C0G	560pF	±5%	630	FK20C0G2J562J	
C0G	680pF	±5%	630	FK20C0G2J682J	

FK22 型

形状・尺寸

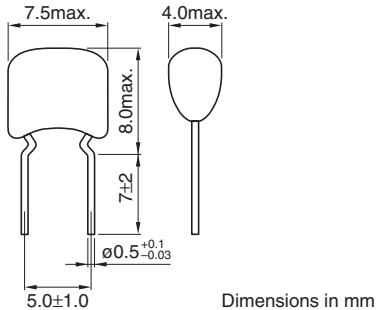

Dimensions in mm

额定电压 Edc: 100 to 630V

温度特性	电容	容差	额定电压 E _{dc} (V)	品名
				FK22 型
C0G	6800pF	±5%	100	FK22C0G2A683J
C0G	0.1μF	±5%	100	FK22C0G2A104J
C0G	2200pF	±5%	250	FK22C0G2E223J
C0G	3300pF	±5%	250	FK22C0G2E333J
C0G	4700pF	±5%	250	FK22C0G2E473J
C0G	820pF	±5%	630	FK22C0G2J822J
C0G	1000pF	±5%	630	FK22C0G2J103J
C0G	1500pF	±5%	630	FK22C0G2J153J
C0G	2200pF	±5%	630	FK22C0G2J223J

⚠ 为了能够更加正确、安全地使用产品，请务必索取能进一步确认详细特性、规格的采购规格书。
记载内容可能因为产品改良等原因不经预告而更改，恕不另行通知。

电容取得范围：种类 2（高介电率类）

FK28、FK18 型

形状·尺寸

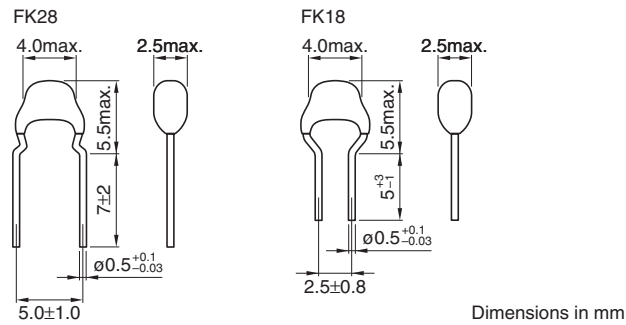

额定电压 Edc: 100 to 250V

温度特性	电容	容差	额定电压 E _{dc} (V)	品名	
				FK28 型	FK18 型
X7R	1000pF	±10%	100	FK28X7R2A102K	FK18X7R2A102K
X7R	1500pF	±10%	100	FK28X7R2A152K	FK18X7R2A152K
X7R	2200pF	±10%	100	FK28X7R2A222K	FK18X7R2A222K
X7R	3300pF	±10%	100	FK28X7R2A332K	FK18X7R2A332K
X7R	4700pF	±10%	100	FK28X7R2A472K	FK18X7R2A472K
X7R	6800pF	±10%	100	FK28X7R2A682K	FK18X7R2A682K
X7R	10000pF	±10%	100	FK28X7R2A103K	FK18X7R2A103K
X7R	15000pF	±10%	100	FK28X7R2A153K	FK18X7R2A153K
X7R	22000pF	±10%	100	FK28X7R2A223K	FK18X7R2A223K
X7S	33000pF	±10%	100	FK28X7S2A333K	FK18X7S2A333K
X7S	47000pF	±10%	100	FK28X7S2A473K	FK18X7S2A473K
X7S	68000pF	±10%	100	FK28X7S2A683K	FK18X7S2A683K
X7S	0.1μF	±10%	100	FK28X7S2A104K	FK18X7S2A104K

⚠ 为了能够更加正确、安全地使用产品，请务必索取能进一步确认详细特性、规格的采购规格书。
记载内容可能因为产品改良等原因不经预告而更改，恕不另行通知。

FK24、FK14 型

形状・尺寸

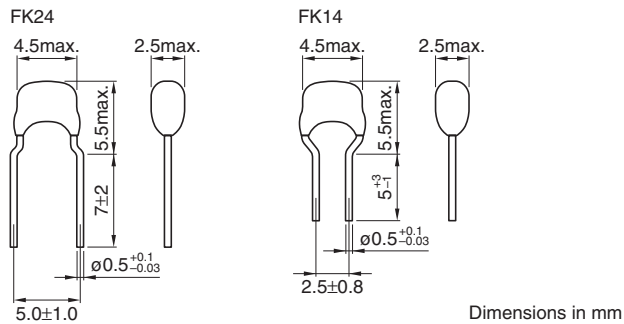

额定电压 Edc: 100 to 250V

温度特性	电容	容差	额定电压 E _{dc} (V)	品名	
				FK24 型	FK14 型
X7R	1000pF	±10%	100	FK24X7R2A102K	FK14X7R2A102K
X7R	1500pF	±10%	100	FK24X7R2A152K	FK14X7R2A152K
X7R	2200pF	±10%	100	FK24X7R2A222K	FK14X7R2A222K
X7R	3300pF	±10%	100	FK24X7R2A332K	FK14X7R2A332K
X7R	4700pF	±10%	100	FK24X7R2A472K	FK14X7R2A472K
X7R	6800pF	±10%	100	FK24X7R2A682K	FK14X7R2A682K
X7R	10000pF	±10%	100	FK24X7R2A103K	FK14X7R2A103K
X7R	15000pF	±10%	100	FK24X7R2A153K	FK14X7R2A153K
X7R	22000pF	±10%	100	FK24X7R2A223K	FK14X7R2A223K
X7R	33000pF	±10%	100	FK24X7R2A333K	FK14X7R2A333K
X7R	47000pF	±10%	100	FK24X7R2A473K	FK14X7R2A473K
X7R	68000pF	±10%	100	FK24X7R2A683K	FK14X7R2A683K
X7R	0.1μF	±10%	100	FK24X7R2A104K	FK14X7R2A104K
X7S	0.15μF	±10%	100	FK24X7S2A154K	FK14X7S2A154K
X7S	0.22μF	±10%	100	FK24X7S2A224K	FK14X7S2A224K
X7S	0.33μF	±10%	100	FK24X7S2A334K	FK14X7S2A334K
X7S	0.47μF	±10%	100	FK24X7S2A474K	FK14X7S2A474K
X7S	0.68μF	±10%	100	FK24X7S2A684K	FK14X7S2A684K
X7S	1μF	±10%	100	FK24X7S2A105K	FK14X7S2A105K
X7R	1000pF	±10%	250	FK24X7R2E102K	FK14X7R2E102K
X7R	1500pF	±10%	250	FK24X7R2E152K	FK14X7R2E152K
X7R	2200pF	±10%	250	FK24X7R2E222K	FK14X7R2E222K
X7R	3300pF	±10%	250	FK24X7R2E332K	FK14X7R2E332K
X7R	4700pF	±10%	250	FK24X7R2E472K	FK14X7R2E472K
X7R	6800pF	±10%	250	FK24X7R2E682K	FK14X7R2E682K
X7R	10000pF	±10%	250	FK24X7R2E103K	FK14X7R2E103K
X7R	15000pF	±10%	250	FK24X7R2E153K	FK14X7R2E153K
X7R	22000pF	±10%	250	FK24X7R2E223K	FK14X7R2E223K

⚠ 为了能够更加正确、安全地使用产品，请务必索取能进一步确认详细特性、规格的采购规格书。
记载内容可能因为产品改良等原因不经预告而更改，恕不另行通知。

FK26、FK16 型

形状・尺寸

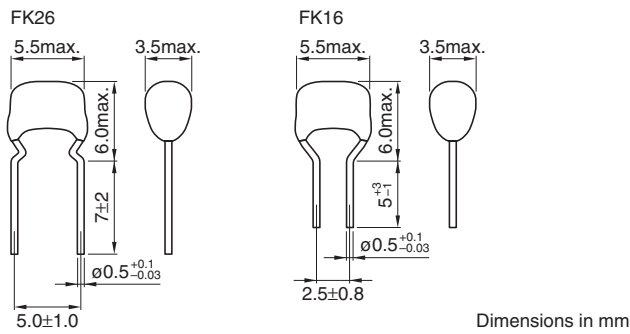

额定电压 Edc: 100 to 630V

温度特性	电容	容差	额定电压 E _{dc} (V)	品名	
				FK26 型	FK16 型
X7R	33000pF	±10%	100	FK26X7R2A333K	FK16X7R2A333K
X7R	47000pF	±10%	100	FK26X7R2A473K	FK16X7R2A473K
X7R	68000pF	±10%	100	FK26X7R2A683K	FK16X7R2A683K
X7R	0.1μF	±10%	100	FK26X7R2A104K	FK16X7R2A104K
X7R	0.15μF	±10%	100	FK26X7R2A154K	FK16X7R2A154K
X7R	0.22μF	±10%	100	FK26X7R2A224K	FK16X7R2A224K
X7R	0.33μF	±10%	100	FK26X7R2A334K	FK16X7R2A334K
X7R	0.47μF	±10%	100	FK26X7R2A474K	FK16X7R2A474K
X7R	0.68μF	±10%	100	FK26X7R2A684K	FK16X7R2A684K
X7R	1μF	±10%	100	FK26X7R2A105K	FK16X7R2A105K
X7S	1.5μF	±10%	100	FK26X7S2A155K	FK16X7S2A155K
X7S	2.2μF	±10%	100	FK26X7S2A225K	FK16X7S2A225K
X7R	15000pF	±10%	250	FK26X7R2E153K	
X7R	22000pF	±10%	250	FK26X7R2E223K	
X7R	33000pF	±10%	250	FK26X7R2E333K	
X7R	47000pF	±10%	250	FK26X7R2E473K	
X7R	68000pF	±10%	250	FK26X7R2E683K	
X7R	0.1μF	±10%	250	FK26X7R2E104K	
X7R	1000pF	±10%	630	FK26X7R2J102K	
X7R	1500pF	±10%	630	FK26X7R2J152K	
X7R	2200pF	±10%	630	FK26X7R2J222K	
X7R	3300pF	±10%	630	FK26X7R2J332K	
X7R	4700pF	±10%	630	FK26X7R2J472K	
X7R	6800pF	±10%	630	FK26X7R2J682K	
X7R	10000pF	±10%	630	FK26X7R2J103K	
X7R	15000pF	±10%	630	FK26X7R2J153K	
X7R	22000pF	±10%	630	FK26X7R2J223K	
X7R	33000pF	±10%	630	FK26X7R2J333K	

为了能够更加正确、安全地使用产品，请务必索取能进一步确认详细特性、规格的采购规格书。
记载内容可能因为产品改良等原因不经预告而更改，恕不另行通知。

FK20、FK11 型

形状・尺寸

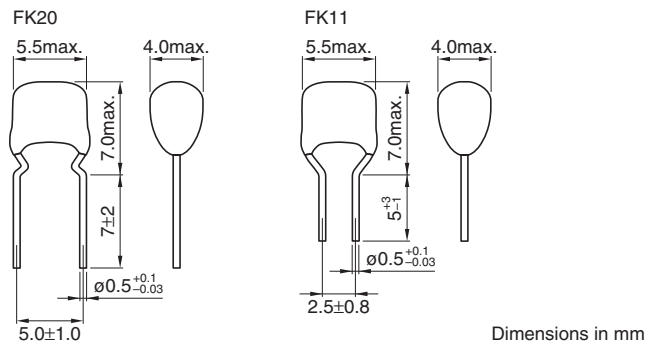

额定电压 Edc: 100 to 630V

温度特性	电容	容差	额定电压 E _{dc} (V)	品名	
				FK20 型	FK11 型
X7R	0.33 μ F	$\pm 10\%$	100	FK20X7R2A334K	FK11X7R2A334K
X7R	0.47 μ F	$\pm 10\%$	100	FK20X7R2A474K	FK11X7R2A474K
X7R	0.68 μ F	$\pm 10\%$	100	FK20X7R2A684K	FK11X7R2A684K
X7R	1 μ F	$\pm 10\%$	100	FK20X7R2A105K	FK11X7R2A105K
X7R	1.5 μ F	$\pm 10\%$	100	FK20X7R2A155K	FK11X7R2A155K
X7R	2.2 μ F	$\pm 10\%$	100	FK20X7R2A225K	FK11X7R2A225K
X7S	3.3 μ F	$\pm 10\%$	100	FK20X7S2A335K	FK11X7S2A335K
X7S	4.7 μ F	$\pm 10\%$	100	FK20X7S2A475K	FK11X7S2A475K
X7R	0.1 μ F	$\pm 10\%$	250	FK20X7R2E104K	
X7R	0.15 μ F	$\pm 10\%$	250	FK20X7R2E154K	
X7R	0.22 μ F	$\pm 10\%$	250	FK20X7R2E224K	
X7R	47000pF	$\pm 10\%$	630	FK20X7R2J473K	
X7R	68000pF	$\pm 10\%$	630	FK20X7R2J683K	

FK22 型

形状・尺寸

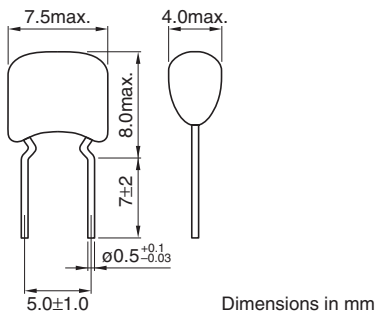

额定电压 Edc: 100 to 630V

温度特性	电容	容差	额定电压 E _{dc} (V)	品名	
				FK22 型	
X7R	0.68 μ F	$\pm 10\%$	100	FK22X7R2A684K	
X7R	1 μ F	$\pm 10\%$	100	FK22X7R2A105K	
X7R	1.5 μ F	$\pm 10\%$	100	FK22X7R2A155K	
X7R	2.2 μ F	$\pm 10\%$	100	FK22X7R2A225K	
X7R	0.15 μ F	$\pm 10\%$	250	FK22X7R2E154K	
X7R	0.22 μ F	$\pm 10\%$	250	FK22X7R2E224K	
X7R	0.33 μ F	$\pm 10\%$	250	FK22X7R2E334K	
X7R	0.47 μ F	$\pm 10\%$	250	FK22X7R2E474K	
X7R	0.1 μ F	$\pm 10\%$	630	FK22X7R2J104K	

●要了解没有记载的电容量及产品说明, 请向本公司询问。

⚠ 为了能够更加正确、安全地使用产品, 请务必索取能进一步确认详细特性、规格的采购规格书。
记载内容可能因为产品改良等原因不经预告而更改, 恕不另行通知。

包装形式

卷带尺寸

FK1 系列

(FK18、FK14、FK16、FK11 型)

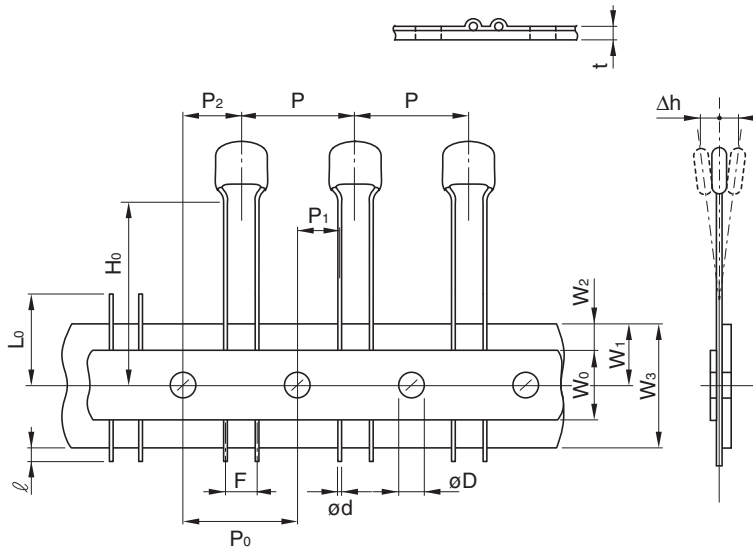

记号	尺寸(mm)
P	12.7±1.0
P0*1	12.7±0.3
P1	5.1±0.7
P2	6.35±1.3
W0	12.0±1.0
W1	9.0±0.5
W2*2	3.0max.
W3	18.0+1.0, -0.5
H0	16.0±0.5
l	1.0max.
t	0.6±0.2
L0*3	11.0max.
F	2.5+0.5, -0.2
ød	ø0.5+0.1, -0.03
øD	ø4.0±0.2
Δh	0±2

*1 20个间距时的累积间距偏差为±2mm。

*2 粘贴胶带不得超出台纸。

*3 连续未穿入孔的产品不超过3个。

FK2 系列

(FK28、FK24、FK26、FK20、FK22 型)

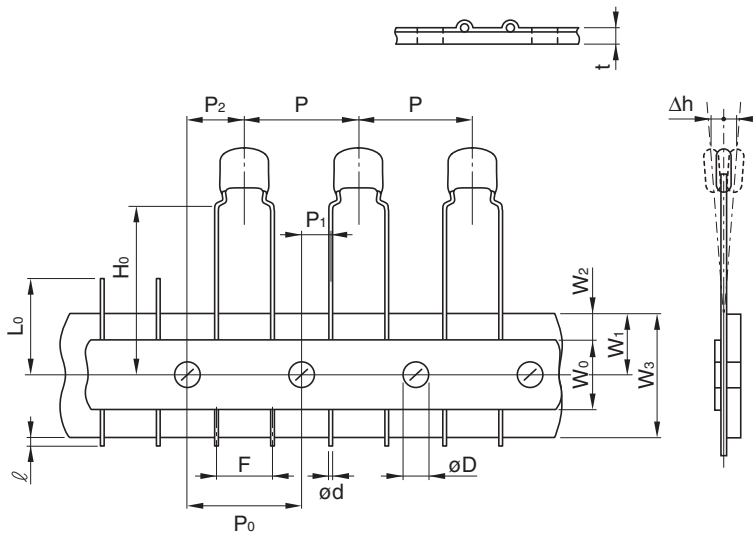

记号	尺寸(mm)
P	12.7±1.0
P0*1	12.7±0.3
P1	3.85±0.7
P2	6.35±1.3
W0	12.0±1.0
W1	9.0±0.5
W2*2	3.0max.
W3	18.0+1.0, -0.5
H0	16.0±0.5
l	1.0max.
t	0.6±0.2
L0*3	11.0max.
F	5.0+0.8, -0.2
ød	ø0.5+0.1, -0.03
øD	ø4.0±0.2
Δh	0±2

*1 20个间距时的累积间距偏差为±2mm。

*2 粘贴胶带不得超出台纸。

*3 连续未穿入孔的产品不超过3个。

包装个数

型名	个数
FK18、FK28	
FK14、FK24	2000个/1箱
FK16、FK26	
FK11、FK20、K22	1500个/1箱

⚠ 为了能够更加正确、安全地使用产品，请务必索取能进一步确认详细特性、规格的采购规格书。
记载内容可能因为产品改良等原因不经预告而更改，恕不另行通知。