

Rated range: 50mA DC12V  
 Insulation resistance: ≥100MΩmin (DC100V)  
 Contact resistance: ≤300mΩ  
 Compressive strength: AC100V(50/60Hz foy 1 minute)  
 Mechanical life: 50000 cycles  
 Operating temperature: -10°C ~ +60°C  
 Operation strength: 50±30gf

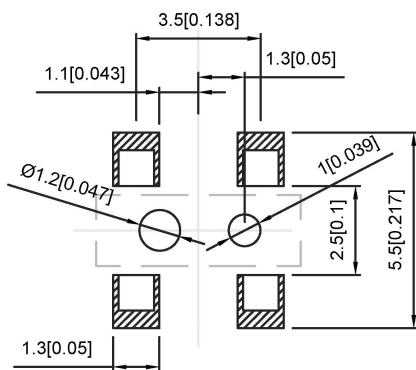

PCB

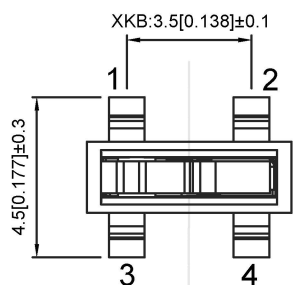
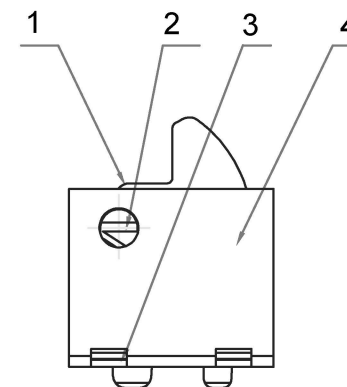
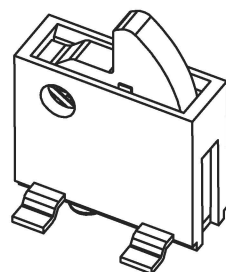
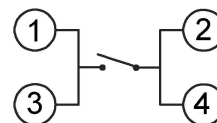

ITEM	PAPT NAMF	QTY	Material	colour
4	Button	1	PPA	black
3	Spring	1	Phosphorous copper	plate with silver
2	Welding foot	1	correrH62-0.2	silvery
1	Pedestal	1	PPA	black

广东星坤科技股份有限公司

生	日期
效	
效	
效	
MARK	文件工程章

DATE	REVISED	APPROVED	UNSPECIFIED TOLERANCES

DSND		DATE		SCALE: N/A	MODEL TYPE: DETECT SWITCH
DWN		DATE		VIEW:	PART NO.:
CHKD		DATE		UNIT: mm/in	DWG NO.: TM-1627S
APPD		DATE		SIZE: A4	
KXB INDUSTRIAL PRECISION CO., LIMITED					WEIGHT: 1.0g
					SHEET: 1/1
					REVISION: A0

www.xk-dg.cn	www.helloxkb.com	www.helloxkb.cn
--------------	------------------	-----------------