



REV.	ECN NO.	REVISED	DATE

NOTE:

1.MATERIAL:

- a.HOUSING: LCP
- b.CONTACT:PHOSPHOR BRONZE
(SURFACE PLATING: Sn100u"-120u")

SEE ORDERING INFORMATION

2.ELECTRIC:

- a.CONTACT RESISTANCE: 50 MILLIOHMS MAX
- b.INSULATION RESISTANCE: 100 MEGA OHMS MIN
- c.DIELECTNIC VOLTAGE: 500V AC ONE SEC LEVEL
- d.OPERATING TEMPERATURE: -25° ~ +85° C

ORDERING INFORMATION

BS-24-B4AK023

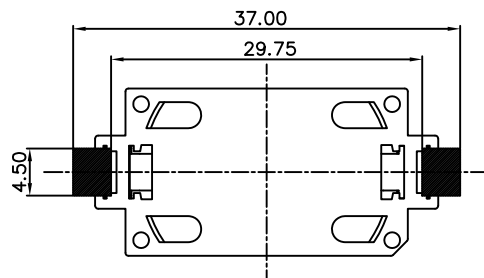
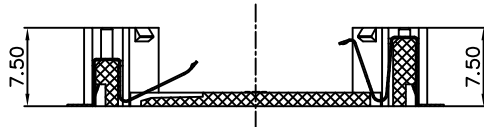
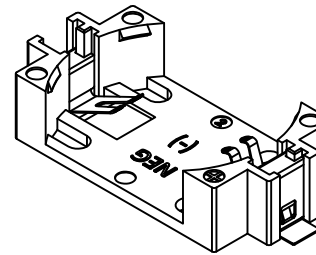
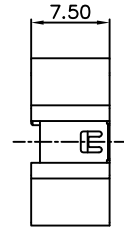
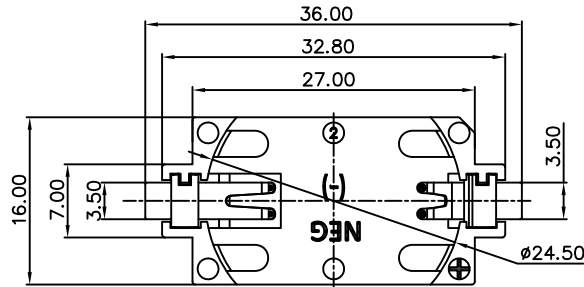
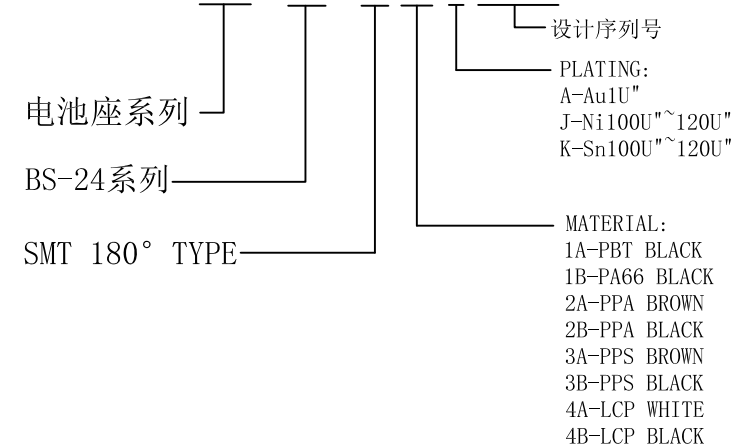

工程部
 2020-06-06
 LQ. HUANG

PCB Layout Diagram
Bottom View

3	TERMINAL(-)	1	PHOSPHOR BRONZE, T=0.15mm	Sn(hight hot高温)-Plating
2	TERMINAL(+)	1	PHOSPHOR BRONZE, T=0.15mm	Sn(hight hot高温)-Plating
1	HOUSE	1	LCP UL94 V-0	WHITE
NO.	PART NAME	Q'TY	MATERIAL	PLATING & COLOR

UNLESS OTHERWISE SPECIFIED TOLERANCES		MYOUNG 美阳 www.meiyangdz.com			
DECIMALS: X :±0.30 X.X :±0.25 X.XX :±0.20 X.XXX :±0.10	ANGLES: X :±1° X.X :±0.5°	DSND	YangFeng	DATE	2020-06-06
WEIGHT:		CHKD	ZhouRuicai	DATE	2020-06-06
SHEET 1 OF 1		APVD	XueShunyong	DATE	2020-06-06
TITLE:		BS-2450-2 Sn SMT			
PART NO.:		BS-24-B4AK023			
DRAW NO.:		MY-CP-0226			