

RECOMMENDED PCB LAYOUT

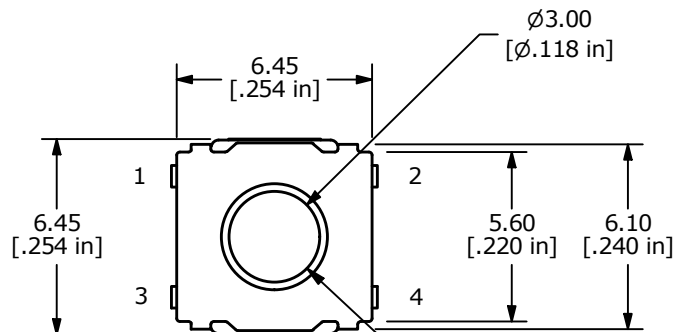

▲ ACTUATOR COLOR: WHITE

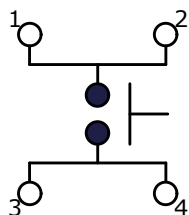

▲ CIRCUIT: SPST

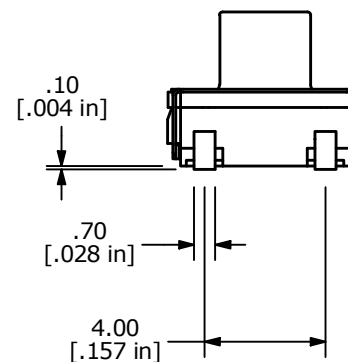
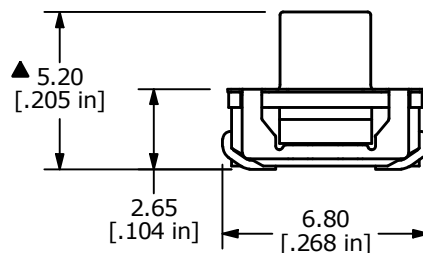

NOTES:

1. ALL DIMENSIONS IN MM [INCH]
2. GENERAL TOLERANCE: x.x = ± 0.4
x.xx = ± 0.25
3. TERM. NOS. FOR REF. ONLY
4. RATING: 50mA, @12V DC
- ▲ 5. OPERATING FORCE: 180 ± 50gf
6. TRAVEL: 0.5 ± 0.3MM
7. CONTACT RESISTANCE: 100 mΩ MAX.
8. INSULATION RESISTANCE: 100MΩ MIN.
9. DIELECTRIC STRENGTH: 250VAC for 1 MINUTE
10. PACKAGING: TAPE AND REEL, 1000 PCS PER REEL
11. CONTACT MATERIAL: SILVER
12. ▲ DENOTES CRITICAL PARAMETER
- ▲ 13. ELECTRICAL LIFE: 3,000,000 CYCLES
14. OPERATING TEMPERATURE: -40°C to 85°C
15. IP67 RATED



C	24657	PCB LAYOUT UPDATE	12/21/20	MJR
B	24373	PCB LAYOUT AND ACTUATOR TO WHITE	7/2/20	MJR
REV	PCR NO	DESCRIPTION	DATE	BY

TITLE TL3145BF180QJ				
SCALE 4:1	DATE 5/12/2020	DR MJR	DWG P031453	REV C

THE INFORMATION CONTAINED IN THIS DOCUMENT IS PROPRIETARY TO E-SWITCH AND IS NOT TO BE COPIED OR TRANSFERRED