

产品概览

NCP6925: Power Management IC (PMIC), 7 Channels, with 2 DC-DC Converters and 5 LDOs

欲看完整文档，请参阅数据表。

The NCP6925 is part of the ON Semiconductor mini-power management IC family. It is optimized to supply battery powered portable application subsystems such as camera modules, microprocessors or any peripherals. This device integrates two high efficiency 1000 mA step-down DC to DC converter with DVS (Dynamic Voltage Scaling) and five low dropout (LDO) voltage regulators in WLCSP-36 2.36 x 2.36 mm package.

特性

- 2.36 x 2.36 mm WLCSP 0.4 mm pitch
- Ultra low quiescent current (140 μ A typ)
- Id detection capability
- 2 general purpose I/O pins
- Two DC-DC converters, efficiency 95%, programmable output voltage from 0.6 V to 3.3 V by 12.5 mV steps, 1000 mA output current capability
- Four low noise, low dropout regulators, programmable output voltage from 0.8 V to 3.5 V by 25 mV steps, 300 mA output current capability, 50 μ Vrms typical low output noise
- Flexible power up and down sequences programmable by I²C
- Triple inputs 10 bits ADC
- 2 DC-DC converters, 95 % efficiency, 1 A output current capability, programmable output voltage from 0.6 V to 3.3 V by 12.5 mV steps
- 5 low dropout regulators, 300 mA output current capability, programmable output voltage from 0.8 V to 3.5 V by 25 mV steps, 50 μ Vrms typical low output noise

For more features, see the data sheet

优势

- Small Space Applications
- Save battery life
- Accessory detection
- Can control internal or external regulators, or can be used as internal sequences triggered inputs

应用

- Cellular Phones
- Battery powered applications power management
- Tablets
- Power supply for processor with low core voltage
- Digital Cameras

终端产品

- Smartphones
- Tablets
- Wearable devices
- MP3 players

应用框图

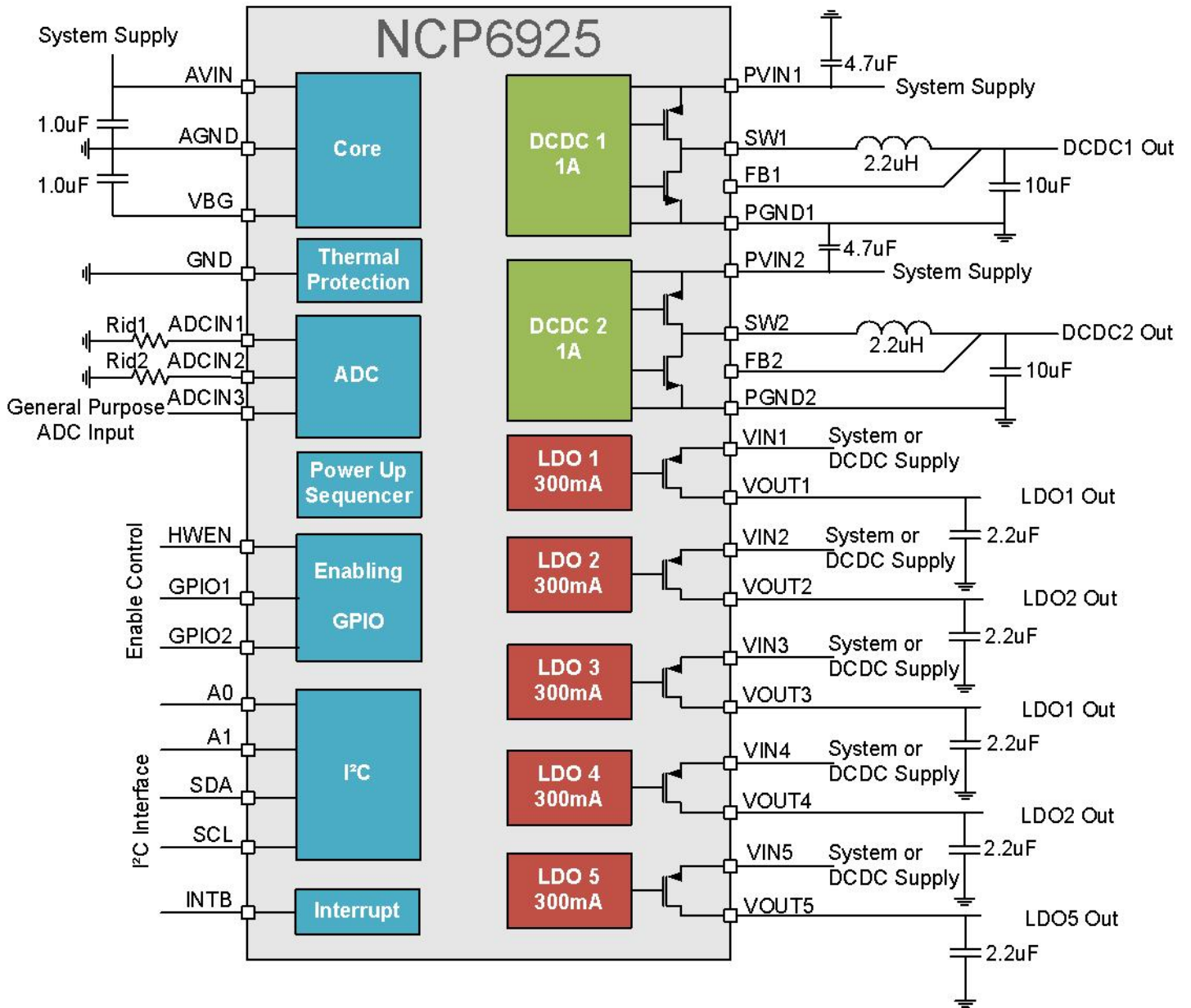

欲了解更多信息，请联系您当地的销售支援 www.onsemi.cn。

创建于：9/9/2021