

AXBM20455

One Cell Lithium-ion/Polymer Battery Protection IC with Thermal Detector



Datasheet — 18 Aug 2021

Description

AXBM20455 is a high integration solution for lithium ion/polymer battery protection designed in BCD (Bipolar, CMOS, DMOS) technology. Integrated are high-accuracy voltage detection circuits and protection detection delay circuits. Packaged into an DFN8 package, it makes an ideal solution in limited space of battery pack. AXBM20455 has all the protection functions required in the battery application including battery thermal detector, over-charging, over-discharging, over-current and load short circuiting protection. The accurate over-charging detection voltage ensures safe and full utilization charging. The ultra-low standby current drains little current from the cell while in storage. The device is not only targeted for digital cellular phones, but also for any other Li-Ion and Li Poly battery-powered information appliances such as wearables requiring long term battery life.

Features

- Thermal detector
- Low current consumption: 1.2 μ A (typ) in operation; 0.04 μ A (max) in power-down
- Charger detection
- High accuracy voltage detection
- Delay times generated internally
- Protections: reverse battery, over-charge voltage, over-discharge voltage, over-charge current, over-discharge current, load short, over-temperature
- 2kV ESD (HBM)

Applications

- Mobile phones
- Power banks
- Any Li-ion / Polymer battery-powered appliances

Table 1 Device Summary

Order code	Package	Packing
AXBM20455	DFN8 (2.0 x 2.0 x 0.75)	Reel

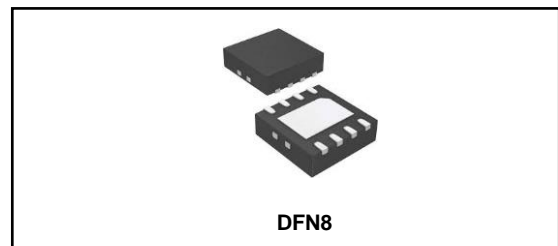

Contents

Description	1
Features	1
Applications.....	1
1 Block Diagram and Application Circuit.....	4
2 Pin Description	5
2.1 Pin Names	5
2.2 Pin Functions	5
3. Electrical Specifications.....	6
3.1 Absolute Maximum Ratings.....	6
3.2 Thermal Data	6
3.3 ESD and Latch Up.....	6
3.4 Electrical Characteristics.....	7
4 Functional Description	8
4.1 Overview.....	8
4.2 Normal Operating Mode	8
4.3 Over-charge Condition	8
4.4 Over-discharge Condition.....	8
4.5 Over-current Condition	9
4.6 Abnormal Charge Current Detection.....	9
4.7 Load Short Condition	9
4.8 Delay Circuits	9
4.9 0V Battery Charging Function.....	10
4.10 Thermal Detector.....	10
4.11 Timing Diagrams	11
5 Package Information	14
5.1 Package Dimensions	14
5.2 Marking Information	15
5.2 Reel Packing Information.....	16
6 Revision History.....	17

List of Figures

Figure 1 Block Diagram	4
Figure 2 Application Circuit.....	4
Figure 3 Pin Connection	5
Figure 4 Over-charge and Over-discharge Voltage Detection	11
Figure 5 Over-discharge Current Detection.....	11
Figure 6 Charger Detection.....	12
Figure 7 Abnormal Charger Detection	12
Figure 8 Thermal Detection (Charger Connects)	13
Figure 9 Thermal Detection (Load Connects)	13
Figure 10 DFN8 (2.0x2.0x0.75) Mechanical Data and Package Dimensions.....	14
Figure 11 Device Markings.....	15
Figure 12 Reel Information	16

List of Tables

Table 1 Device Summary.....	1
Table 2 Pin Functions	5
Table 3 Absolute Maximum Ratings	6
Table 4 Thermal Data.....	6
Table 5 ESD and Latch up.....	6
Table 6 Electrical Characteristics	7
Table 7 Document Revision History.....	17

1 Block Diagram and Application Circuit

Figure 1 Block Diagram

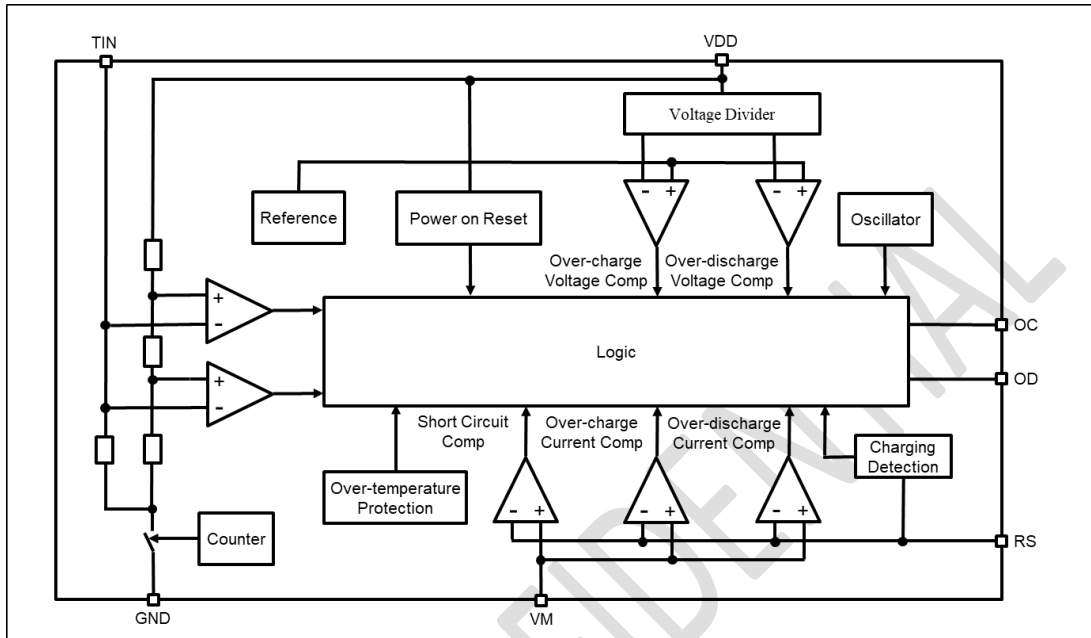
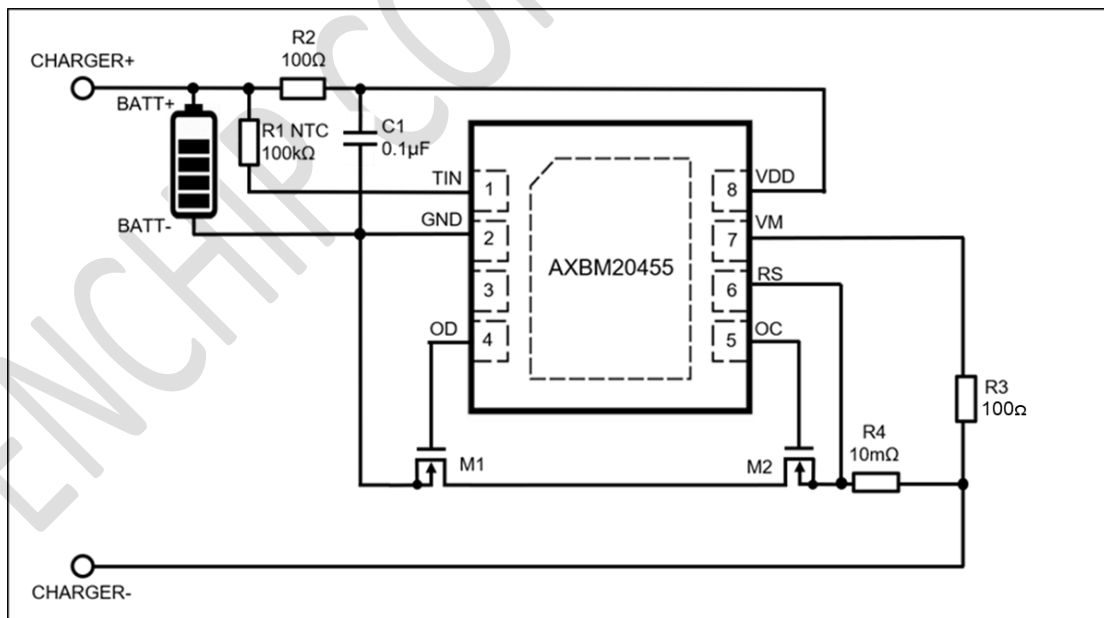

Figure 2 Application Circuit



* In applications where small battery capacity (<200mAH) is used, R2 and C1 are recommended to be increased to 330Ω and 2.2μF respectively.

2 Pin Description

2.1 Pin Names

Figure 3 Pin Connection

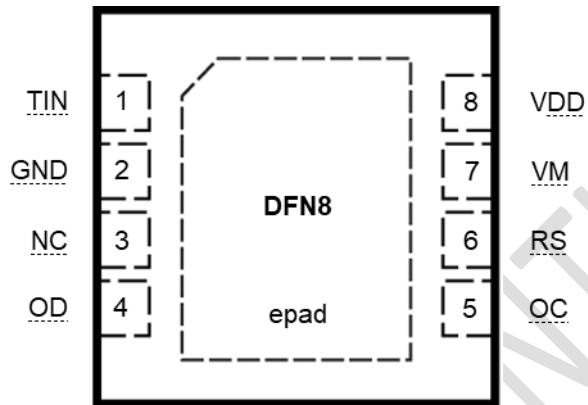

2.2 Pin Functions

Table 2 Pin Functions

Pin number	Pin name	Description
1	TIN	Thermistor input pin for temperature detection.
2	GND	Ground. Connect the negative terminal of the battery to this pin.
3	NC	No connection.
4	OD	Output pin of over-discharge detection.
5	OC	Output pin of over-charge detection.
6	RS	Over-current detector input pin.
7	VM	Charger negative input pin.
8	VDD	Power Supply.
EPAD		Connecting it to GND.

3. Electrical Specifications

3.1 Absolute Maximum Ratings

Table 3 Absolute Maximum Ratings

Symbol	Parameter	Value	Unit
VDD	Supply voltage	-0.3 to +15	V
VM, RS	Input pin voltage	VDD-30 to VDD+0.3	V
OC	Output pin voltage	VDD-30 to VDD+0.3	V
OD	Output pin voltage	GND-0.3 to VDD+0.3	V
VTIN	TIN pin voltage	GND-0.3 to VDD+0.3	V
Ptot	Power dissipation Tamb = +25°C	2.5	W
Tj	Junction temperature	150	°C
Tstg	Storage temperature	-55 to +150	°C

3.2 Thermal Data

Table 4 Thermal Data

Symbol	Parameter	Value	Unit
Rth j-amb	Thermal resistance junction-to-case	5	°C/W
Rth j-case	Thermal resistance junction-to-ambient	43	°C/W

3.3 ESD and Latch Up

Table 5 ESD and Latch up

Symbol	Parameter	Value	Unit
VDD, VM, GND	ESD HBM	2,000	V
VDD, VM	Latch Up JESD78, Class A	≥ 100	mA

3.4 Electrical Characteristics

VDD = 3.6V; Tamb = +25°C; unless otherwise specified.

Table 6 Electrical Characteristics

Symbol	Parameter	Test condition	Min	Typ	Max	Unit
VDD	Operating input voltage		1.5		5.0	V
Vst	Minimum charger voltage for 0V charging				1.8	V
Detection Voltage						
Voc	Over-charge detection voltage		4.25	4.30	4.35	V
Vocr	Over-charge release voltage		4.05	4.10	4.15	V
Vod	Over-discharge detection voltage		2.4	2.5	2.6	V
Vodr	Over-discharge release voltage		2.9	3.0	3.1	V
Detection Current						
Ioc	Over-charge current detection	R _{sense} =3mΩ		5		A
Iod	Over-discharge current detection	R _{sense} =3mΩ		5		A
Ishort	Load short detection	R _{sense} =3mΩ		11		A
Current Consumption						
Iop	Current consumption in normal operation	VDD=3.6V VM=0V		1.2		μA
Ipd	Current consumption in power down	VDD=2.0V VM float			0.04	μA
VM Internal Resistance						
Rvmd	Internal resistance between VM and VDD	VDD=2.0V VM float		300		kΩ
Rvms	Internal resistance between VM and GND	VDD=3.6V VM=1.0V		100		kΩ
Over Temperature Protection						
Tshd+	Over-temperature protection			130		°C
Tshd-	Over-temperature recovery			110		°C
Temperature Detection						
Tdet1	Thermal detector1 threshold	NTC resistor: muRata part = NCP03WF104F05RL Resistance = 100kΩ±1%(25°C) B-Constant = 4250K±1%	42	45	48	°C
Trel1	Thermal release1 threshold		37	40	43	°C
Tdet2	Thermal detector2 threshold		57	60	63	°C
Trel2	Thermal release2 threshold		52	55	58	°C
RTIN	TIN pin input resistance		91	96	101	kΩ
Detection Delay Time						
Tvoc	Over-charge voltage detect delay		70	100	130	ms
Tvod	Over-discharge voltage detect delay		60	80	100	ms
Tioc	Over-charge current detect delay		6	12	18	ms
Tiod	Over-discharge current detect delay		5	10	15	ms
Tshort	Load short detection delay		130	180	230	μs
TTs	Temperature sense time		10	13	16	ms
TTns	Temperature non-sensing time		400	520	640	ms
TTdet	Thermal detection delay		800	1000	1200	ms
TTrel	TTdet release delay		100	125	150	ms

4 Functional Description

4.1 Overview

AXBM20455 monitors the voltage and current of a battery and provides high accuracy protection for:

- Over-charge voltage
- Over-discharge voltage
- Over-charge current
- Over-discharge current
- Short circuit conditions by disconnecting the battery from the load or charger
- Thermal protection

4.2 Normal Operating Mode

If no exceptional condition is detected, charging and discharging can be carried out freely. This condition is called normal operating mode.

4.3 Over-charge Condition

When the battery voltage becomes higher than the over-charge detection voltage (V_{oc}) during charging under normal condition and, the state continues for the over-charge detection delay time (T_{voc}) or longer, OC becomes low and stop charging by turning off the external charging Mosfet. This condition is called over-charge condition.

The over-charge condition is released in the following two cases:

1. When the battery voltage drops below the over-charge release voltage (V_{ocr}), OC becomes high, turn on the external charging Mosfet and return to normal condition.
2. When a load is connected and discharging starts, AXBM20455 will turn on the external charging Mosfet and return to normal condition.

4.4 Over-discharge Condition

When the battery voltage drops below the over-discharge detection voltage (V_{od}) during discharging under normal condition and, it continues for the over-discharge detection delay time (T_{vod}) or longer, OD becomes low and stop discharging by turning off the external discharging Mosfet. This condition is called over-discharge condition.

After the discharging Mosfet being turned off, VM pin will be pulled up by the resistor R_{vmd} between VM and VDD within AXBM20455. 1.5s later, AXBM20455 will go into power-down mode with current (I_{pd}) reduced to $0.04\mu A$.

This condition is called power-down condition. The VM and VDD pins are shorted by R_{vmd} under the over-discharge and power-down conditions.

The power-down condition is released when a charger is connected and the potential difference between VM and VDD becomes 1.3V (typ) or higher (load short detection voltage). During this time, the external discharging Mosfet is still off.

When the battery voltage reaches the over-discharge release voltage (V_{odr}) or higher, OD becomes high, turn on the external discharging Mosfet and change to normal condition from the over-discharge condition.

4.5 Over-current Condition

When the discharging current becomes equal to or higher than a specified value (the VM pin voltage is equal to or higher than the over-current detection voltage) during discharging under normal condition and, the state continues for the over-current detection delay time or longer, OD becomes low and stop discharging by turning off the external discharging Mosfet. This condition is called over-current condition. (The over-current includes over-current or load short) The VM and GND pins are shorted internally by Rvms under over-current condition. When a load is connected, the VM pin voltage is equal to VDD voltage due to the load. The over-current condition returns to normal condition when the load is released and the impedance between Pack+ and Pack- pins becomes higher than the automatic recoverable impedance. When the load is removed, the VM pin goes back to GND potential since it is shorted to GND via Rvms. Detecting that the VM pin potential is lower than the over-current detection voltage (Voc), AXBM20455 returns to normal condition.

4.6 Abnormal Charge Current Detection

If the VM pin voltage drops below the charger detection voltage (Vcha) during charging under the normal condition and, it continues for the delay time of Tioc or longer, OC becomes low and stop charging by turning off the external charging Mosfet. This action is called abnormal charge current detection.

Abnormal charge current detection starts working when OD is high and the VM pin voltage drops below the charger detection voltage (Vcha). When an abnormal charge current flows into a battery in over-discharge condition, OC becomes low and stop charging by turning off the external charging Mosfet.

Abnormal charge current detection is released when the voltage difference between the VM pin and GND pin becomes lower than the charger detection voltage (Vcha) by separating the charger. Since the 0V battery charging function has higher priority than the abnormal charge current detection function, abnormal charge current may not be detected by the 0V battery charging function while the battery voltage is low.

4.7 Load Short Condition

If voltage of VM pin is equal or below short protection voltage (Vshort), AXBM20455 will stop discharging and battery will be disconnected from load. The maximum delay time to switch off the current is Tshort. This status is released when VM voltage is higher than the short protection voltage (Vshort), such as when disconnecting the load.

Precaution:

If < 200mAh Li-Battery is shorted, the voltage of battery may be pulled down to 0V~1V quickly so that the short-circuiting protection logic may not work properly. Increasing the R1 and C1 to 330Ω and 2.2μF can solve this problem.

4.8 Delay Circuits

The detection delay time for over-discharge current and load short-circuiting starts when over-discharge current is detected. As soon as over-discharge current or load short is detected over detection delay, AXBM20455 will stop discharging. When battery voltage falls below over-discharge detection voltage due to over-discharge current, AXBM20455 will stop discharging by over-discharge current detection. In this case the recovery of battery voltage is so slow that if battery voltage after over-discharge voltage detection delay time is still lower than over-discharge detection voltage, AXBM20455 will shift to power-down mode.

4.9 0V Battery Charging Function

This function enables the charging of a connected battery whose voltage is 0V due to self-discharge. When a charger having 0V battery starts charging charger voltage (V_{0cha}) or higher is connected between Pack+ and Pack- pins, OC is fixed to VDD potential. When the voltage between the gate and the source of the charging control Mosfet becomes equal to or higher than the turn-on voltage by the charger voltage, the charging control Mosfet is turned on to start charging. At this time, the discharging control Mosfet is turned off and the charging current flows through the internal parasitic diode in the discharging control Mosfet. If the battery voltage becomes equal to or higher than the over-discharge release voltage (V_{odr}), normal condition returns.

Note:

- (1) Some battery providers do not recommend charging of completely discharged batteries. Please refer to battery providers before the selection of 0V battery charging function.
- (2) When a battery is connected to the device for the first time, the device may not enter the normal condition in which discharging is possible. In this case, set the VM pin voltage equal to the GND voltage (short the VM and GND pins or connect a charger) to enter the normal condition.

4.10 Thermal Detector

AXBM20455 converts the temperature, which is detected by a built-in resistor and a thermistor connected with TIN pin, to the voltage and monitors it. The thermistor works only for a period of 10ms for every 400ms cycle to save the supply current.

When the temperature higher than T_{det1} is detected and sustained over TT_{det} , the charging will be stopped by turning off the charging control Mosfet. Likewise, when the temperature higher than T_{det2} is detected and sustained over TT_{det} , discharging will be stopped by turning off the discharging control Mosfet.

When the temperature decreases lower than T_{rel1} or T_{rel2} respectively, the device goes back to normal mode.

AXBM20455 requires an NTC thermistor having the following characteristics:

- Vender: muRata
- Part number: NCP03WF104F05RL
- Resistance = $100k\Omega \pm 1\%$ ($25^{\circ}C$)
- B-Constant = $4250K \pm 1\%$

4.11 Timing Diagrams

Figure 4 Over-charge and Over-discharge Voltage Detection

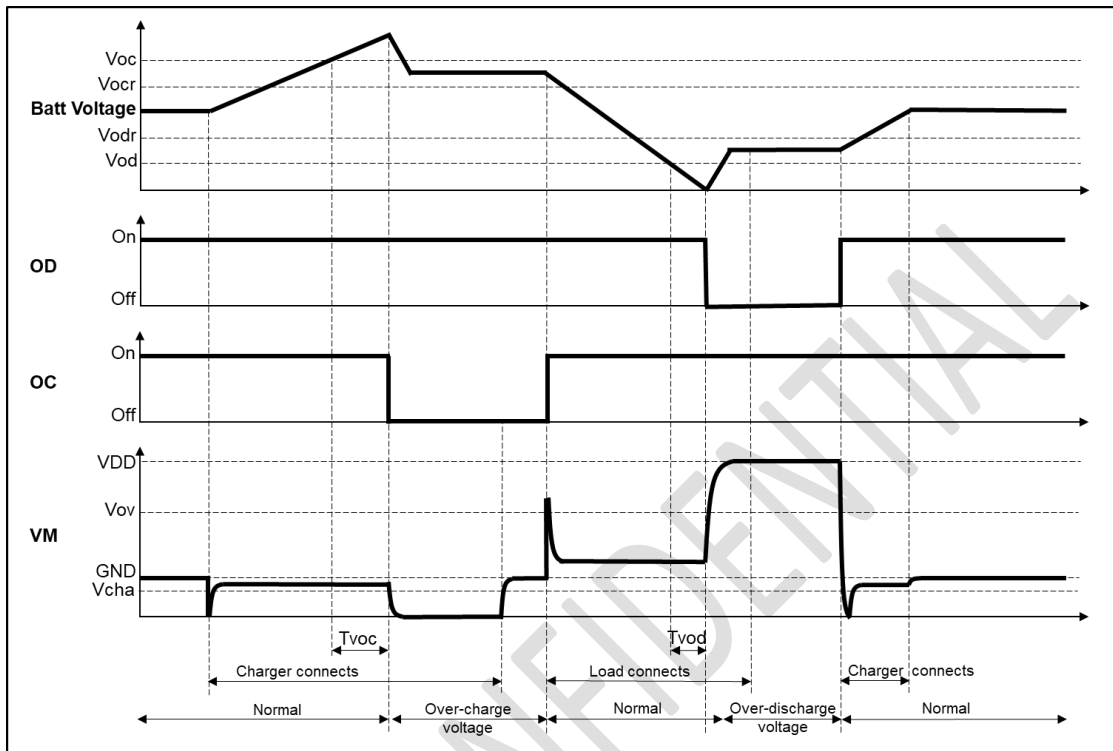

Figure 5 Over-discharge Current Detection

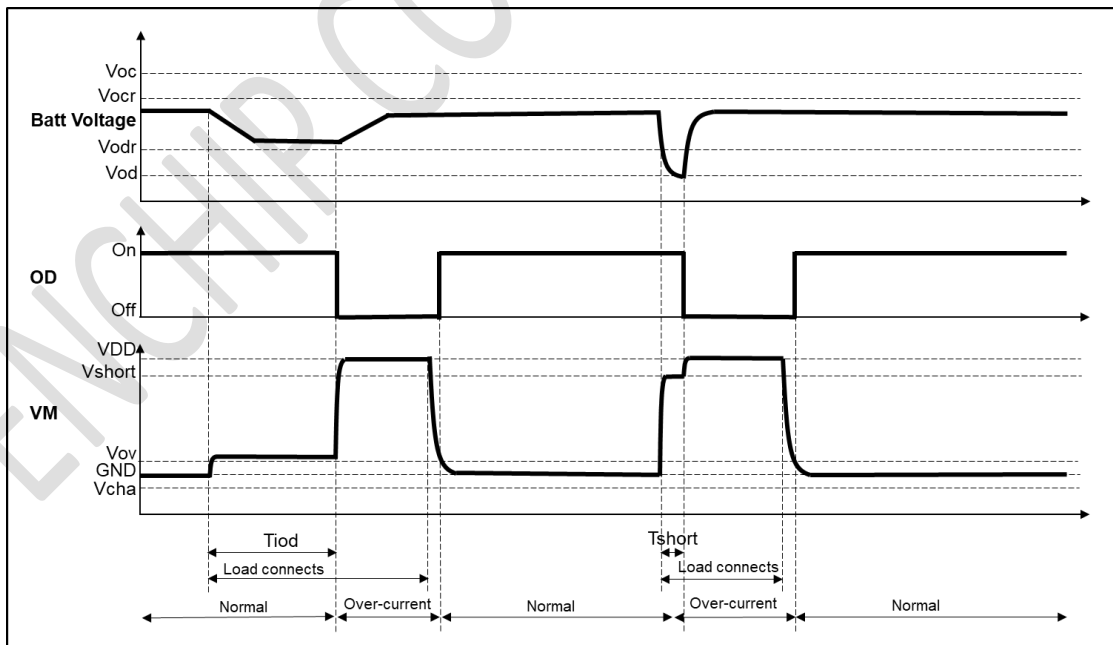

Figure 6 Charger Detection

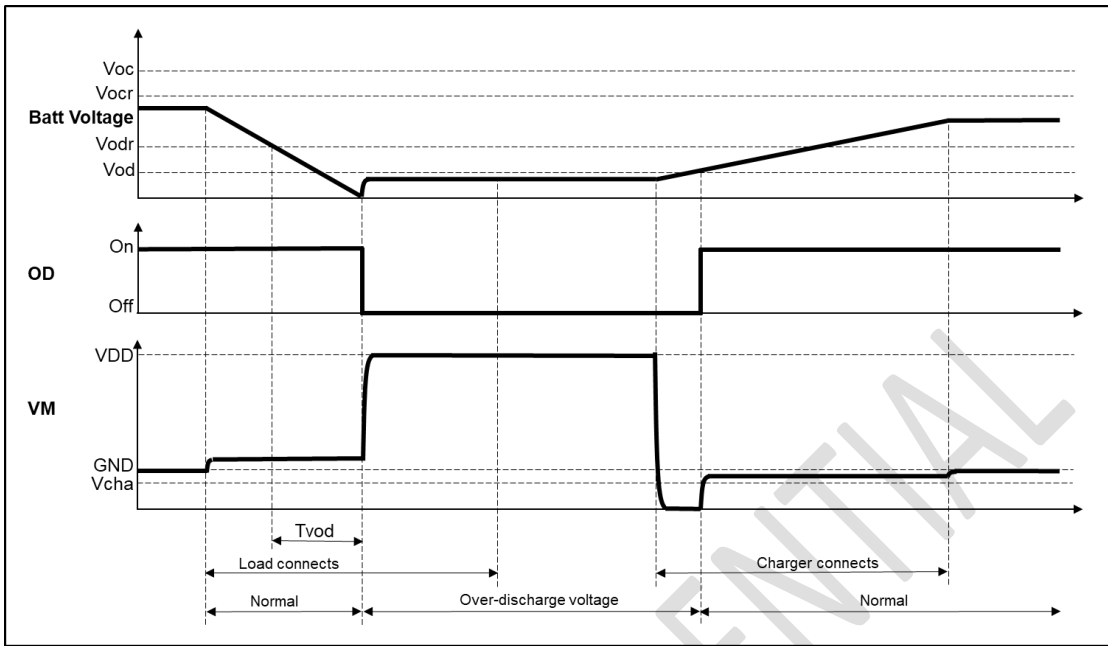

Figure 7 Abnormal Charger Detection

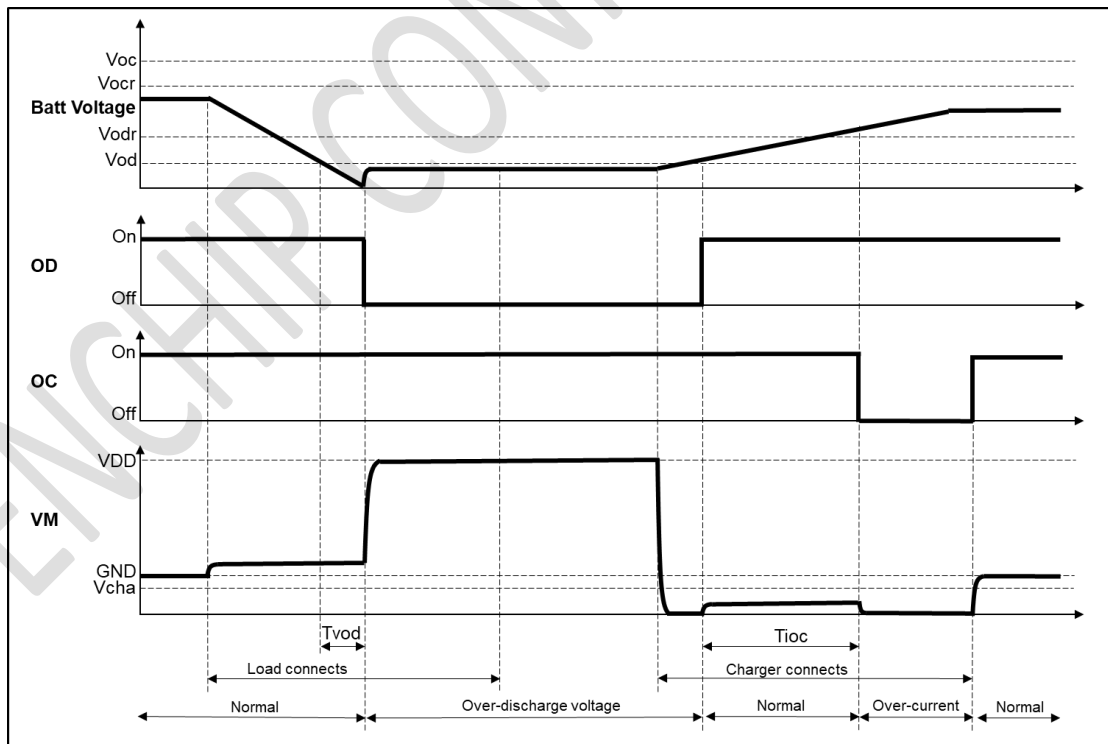

Figure 8 Thermal Detection (Charger Connects)

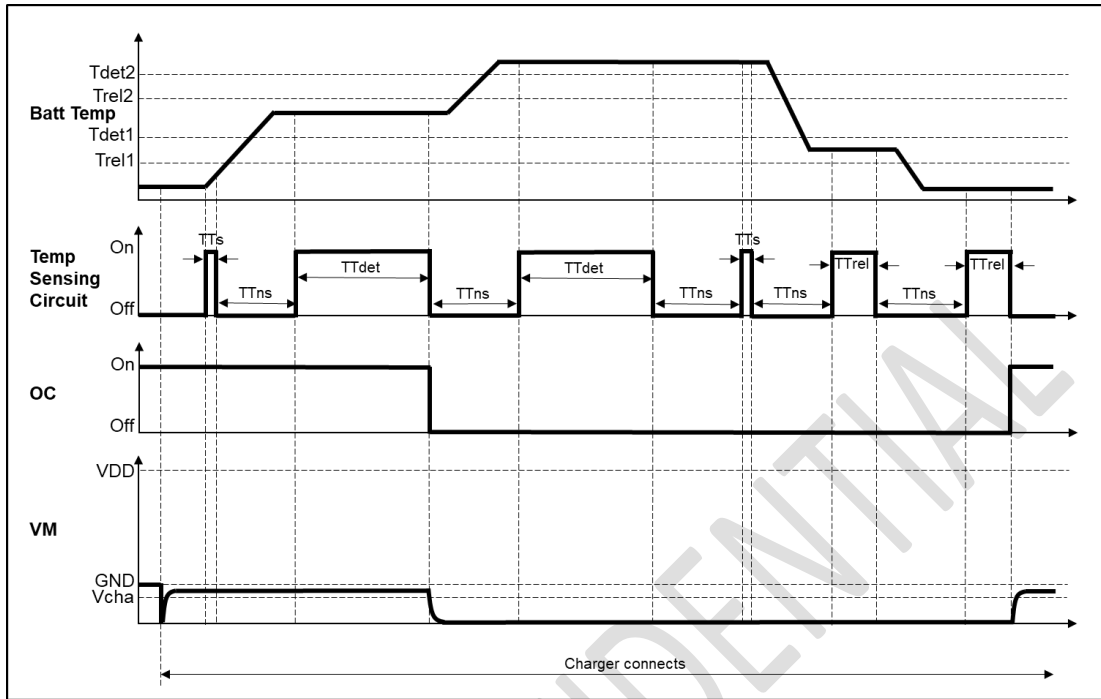
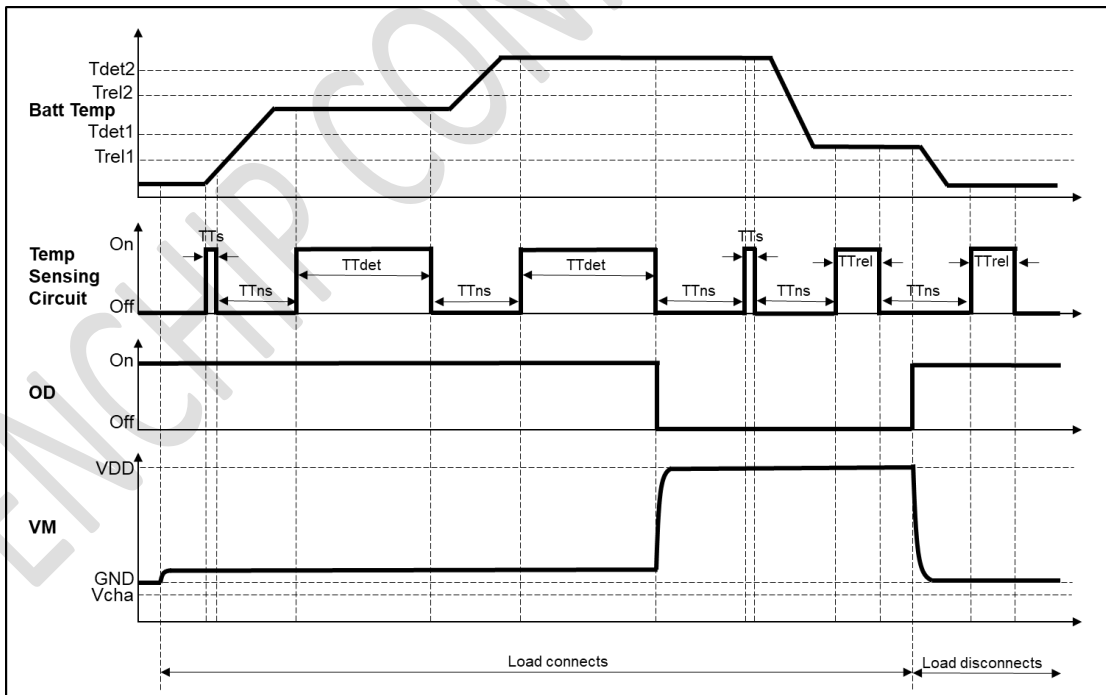

Figure 9 Thermal Detection (Load Connects)



5 Package Information

5.1 Package Dimensions

Figure 10 DFN8 (2.0x2.0x0.75) Mechanical Data and Package Dimensions

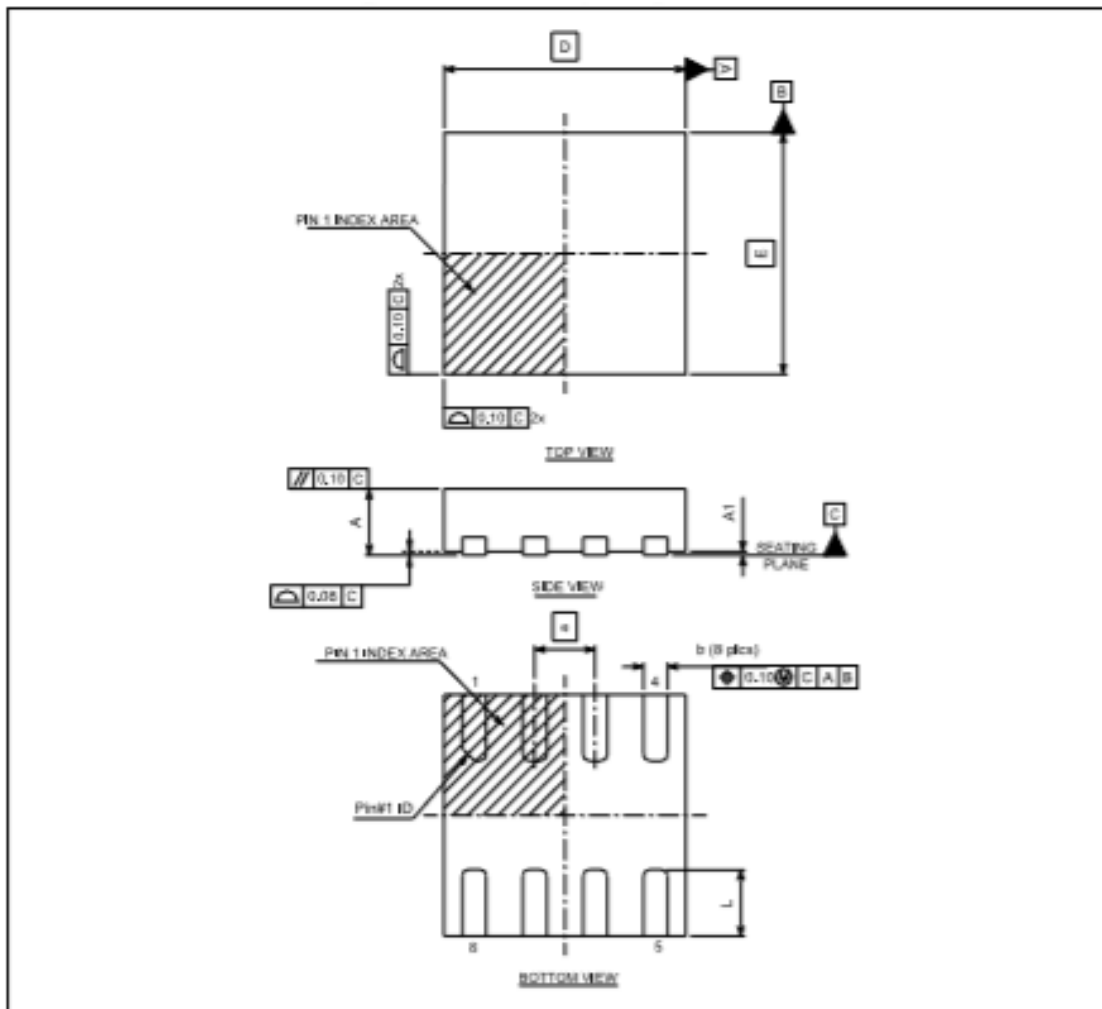
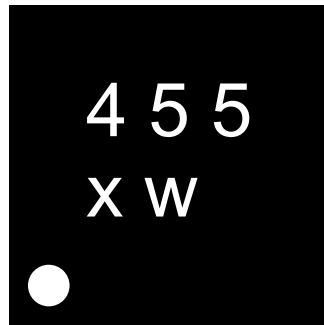

Table 8: DFN8 2x2 mechanical data

Ref.	Dimensions					
	Millimeters			Inches		
	Min.	Typ.	Max.	Min.	Typ.	Max.
A	0.70	0.75	0.80	0.028	0.030	0.031
A1	0.00	0.02	0.05	0.000	0.001	0.002
b	0.15	0.20	0.25	0.006	0.008	0.010
D		2.00			0.079	
E		2.00			0.079	
e		0.50			0.020	
L	0.045	0.55	0.65	0.018	0.022	0.026
N	8					

5.2 Marking Information

Figure 11 Device Markings



Laser mark circle to indicate pin 1

2 rows of Alphanumeric

Row 1: 455 to indicate device code AXBM20455

Row 2: x to indicate revision number.

w to indicate month of production. 1,2,3,4,5,6,7, A, C, D, E, F

5.3 Reel Packing Information

Figure 12 Reel Information

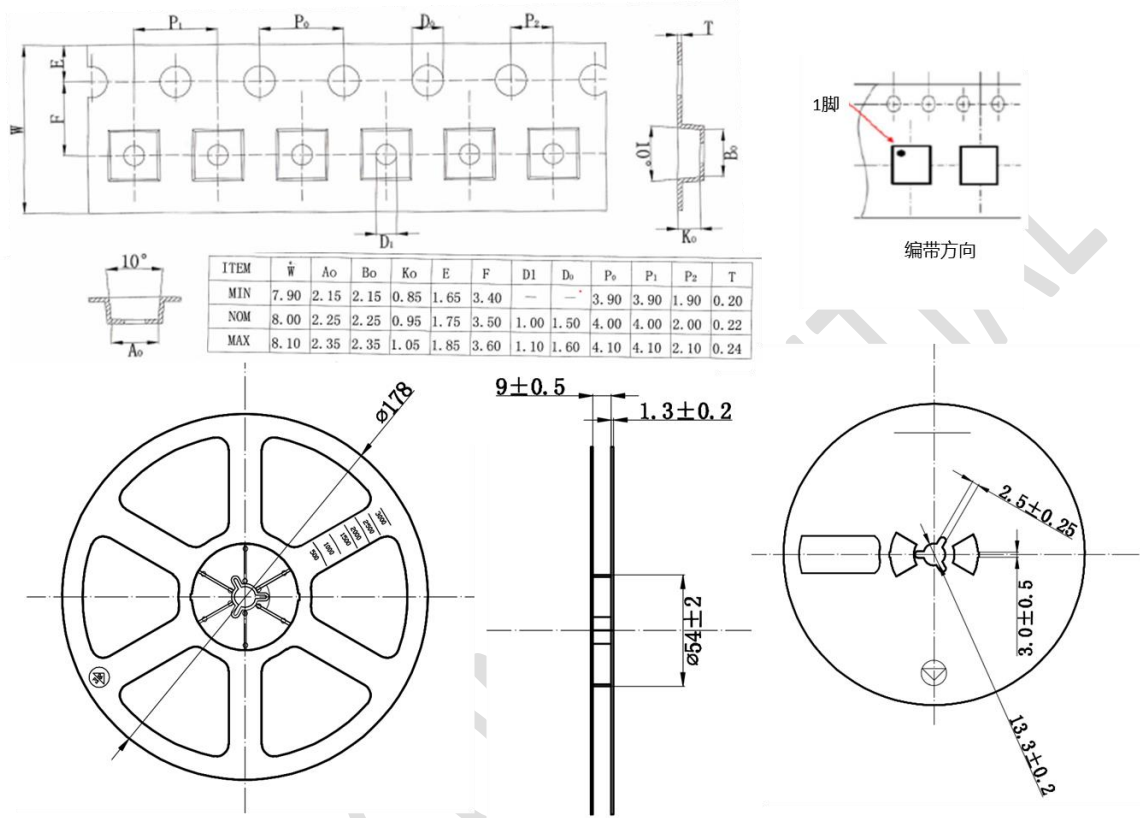

6 Revision History

Table 7 Document Revision History

Date	Version	Description
Jun 2020	1.00	First version.
Aug 2021	2.00	Revised pinout and package dimensions