

AXBM20341x

0.4A One Cell Lithium-ion/Polymer Battery Protection IC



Datasheet — 16 Aug 2021

Description

AXBM20341x is a high integration solution for lithium ion/polymer battery protection designed in BCD (Bipolar, CMOS, DMOS) technology. Integrated are smart power mosfet, high-accuracy voltage detection circuits and protection detection delay circuits. Packaged into an DFN4, 1X1x0.37 package, it makes an ideal solution in limited space of battery pack. AXBM20341x has all the protection functions required in the battery application including over-charging, over-discharging, over-current and load short circuiting protection. The accurate over-charging detection voltage ensures safe and full utilization charging. The ultra-low standby current drains little current from the cell while in storage. The device is not only targeted for digital cellular phones, but also for any other Li-Ion and Li Poly battery-powered information appliances such as wearables requiring long term battery life.

Features

- Integrated smart power mosfet, with R_{dson} 100m Ω (typ).
- Charging and discharging current 0.4A (typ).
- Low current consumption: 0.7 μ A (typ) in operation; 1nA (typ) in power-down.
- Charger detection.
- High accuracy voltage detection.
- Delay times generated internally.
- Protections: reverse battery, over-charge voltage, over-discharge voltage, over-charge current, over-discharge current, load short, over-temperature.
- 4kV ESD (HBM).

Applications

- TWS
- Wearables
- Any Li-ion / Polymer battery-powered appliances

Table 1 Device Summary

Order code	Package	Packing
AXBM20341x x: A=4.28V V_{OC} B=4.42V V_{OC}	DFN4 epad 1.0 x 1.0 x 0.37	Reel

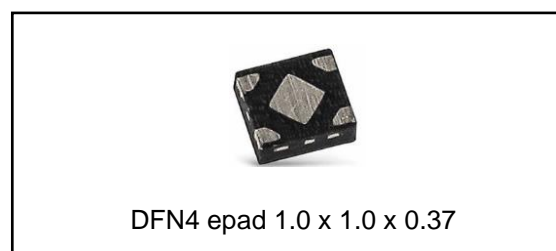

Contents

Description.....	1
Features.....	1
Applications	1
1 Block Diagram and Application Circuit	4
2 Pin Description.....	5
2.1 Pin Names	5
2.2 Pin Functions	5
3 Electrical Specifications	6
3.1 Absolute Maximum Ratings	6
3.2 Thermal Data	6
3.3 ESD and Latch Up	6
3.4 Electrical Characteristics.....	7
4 Functional Description.....	8
4.1 Overview.....	8
4.2 Normal Operating Mode.....	8
4.3 Over-charge Condition	8
4.4 Over-discharge Condition	8
4.5 Over-current Condition.....	9
4.6 Abnormal Charge Current Detection	9
4.7 Load Short Condition	9
4.8 Delay Circuits.....	9
4.9 0V Battery Charging Function	10
4.10 Timing Diagrams.....	10
5 Package Information	13
5.1 Package Outline Dimensions	13
5.2 Package Marking Information	14
6 Packing Information	15
7 Revision History	16

List of Figures

Figure 1 Block Diagram.....	4
Figure 2 Application Circuit	4
Figure 3 Pin Connection.....	5
Figure 4 Over-charge and Over-discharge Voltage Detection	10
Figure 5 Over-discharge Current Detection.....	11
Figure 6 Charger Detection.....	11
Figure 7 Abnormal Charger Detection.....	12
Figure 8 DFN4 EPAD 1.0 x 1.0 x 0.37 mm Mechanical Data and Package Dimensions.....	13
Figure 9 DFN4 EPAD 1.0 x 1.0 x 0.37 mm Marking Information.....	14
Figure 10 Reel Packing Information	15

List of Tables

Table 1 Device Summary.....	1
Table 2 Pin Functions	5
Table 3 Absolute Maximum Ratings.....	6
Table 4 Thermal Data	6
Table 5 ESD and Latch up	6
Table 6 Electrical Characteristics	7
Table 7 Document Revision History	16

1 Block Diagram and Application Circuit

Figure 1 Block Diagram

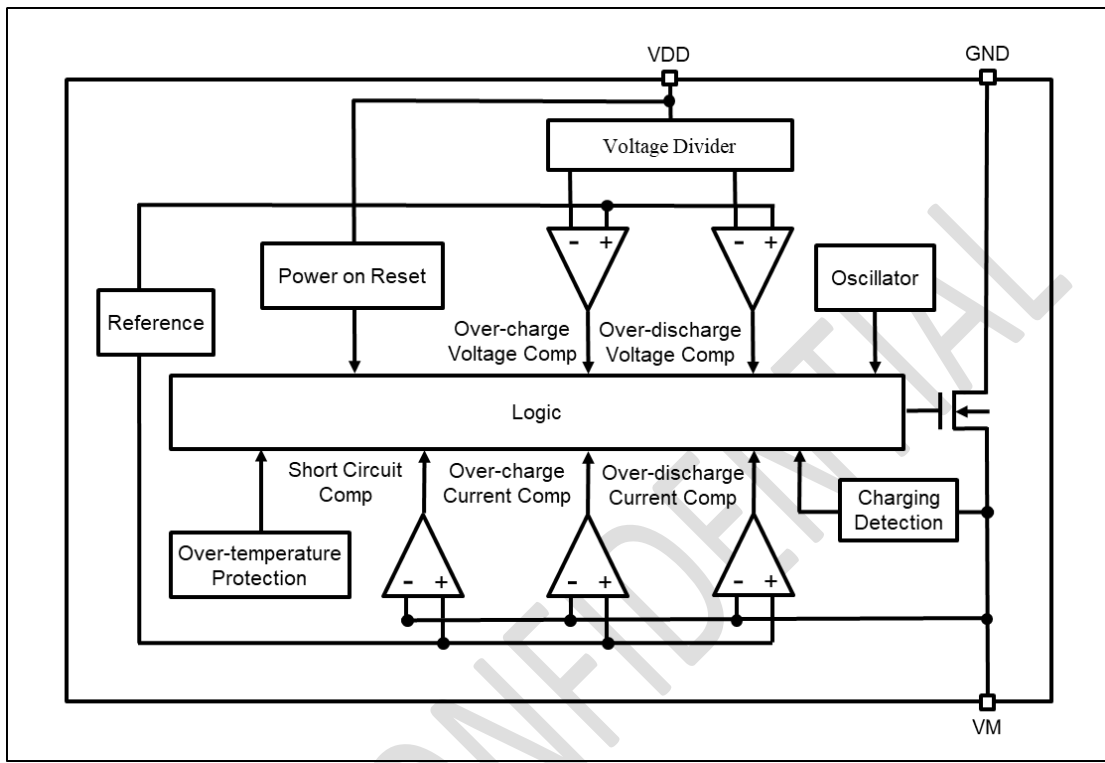
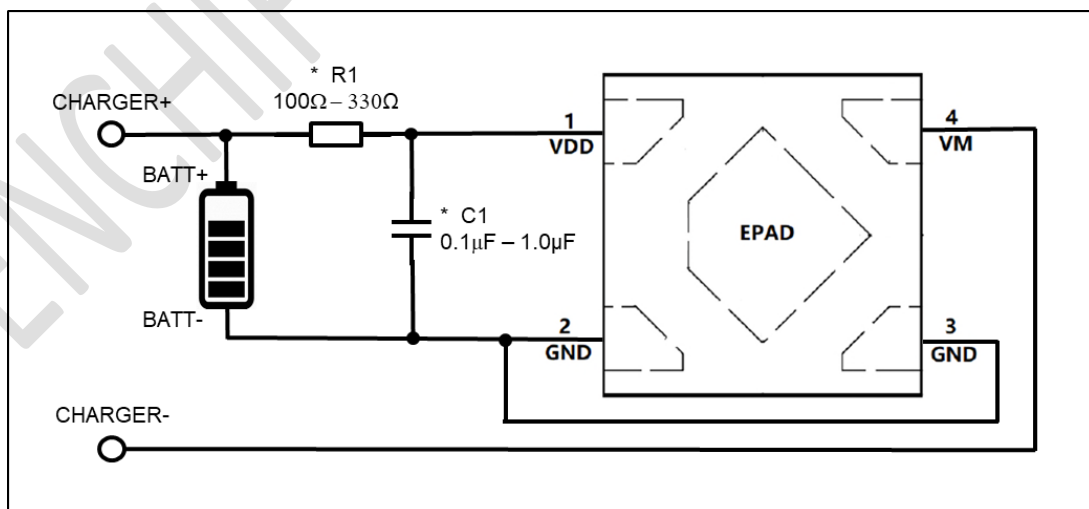

Figure 2 Application Circuit



* In applications where small battery capacity (<50mAH) is used, R1 and C1 are recommended to be increased to 330Ω and 1.0μF respectively.

2 Pin Description

2.1 Pin Names

Figure 3 Pin Connection

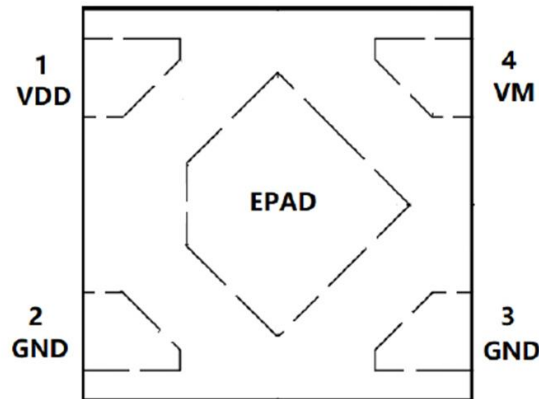

2.2 Pin Functions

Table 2 Pin Functions

Pin number	Pin name	Description
1	VDD	Power Supply.
2	GND	Ground. Connect the negative terminal of the battery to this pin.
3	GND	Ground. Connect the negative terminal of the battery to this pin.
4	VM	The internal mosfet switch connects this terminal to GND.
EPAD		Not used. Suggest connecting it to GND.

3 Electrical Specifications

3.1 Absolute Maximum Ratings

Table 3 Absolute Maximum Ratings

Symbol	Parameter	Value	Unit
VDD	Supply voltage	-0.3 to +6	V
VM	Input pin voltage	-6 to +10	V
Ptot	Power dissipation Tamb = +25°C	0.3	W
Tj	Junction temperature	150	°C
Tstg	Storage temperature	-55 to +150	°C

3.2 Thermal Data

Table 4 Thermal Data

Symbol	Parameter	Value	Unit
Rth j-case	Thermal resistance junction-to-case max.	130	°C/W

3.3 ESD and Latch Up

Table 5 ESD and Latch up

Symbol	Parameter	Value	Unit
VDD, VM, GND	ESD HBM	4,000	V
VDD, VM	Latch Up JESD78, Class A	≥ 100	mA

3.4 Electrical Characteristics

VDD = 3.6V; Tamb = +25°C; unless otherwise specified.

Table 6 Electrical Characteristics

Symbol	Parameter	Test condition	Min	Typ	Max	Unit
Detection Voltage						
Voc	Over-charge detection voltage	AXBM20341A	4.250	4.280	4.310	V
		AXBM20341B	4.390	4.420	4.450	V
Vocr	Over-charge release voltage	AXBM20341A	4.030	4.080	4.130	V
		AXBM20341B	4.170	4.220	4.270	V
Vod	Over-discharge detection voltage		2.7	2.8	2.9	V
Vodr	Over-discharge release voltage		2.9	3.0	3.1	V
Detection Current						
loc	Over-charge current detection	VDD=3.6V	0.25	0.4	0.55	A
lod	Over-discharge current detection	VDD=3.6V	0.25	0.4	0.55	A
Ishort	Load short detection	VDD=3.6V	0.7	1.0	1.3	A
Current Consumption						
Iop	Current consumption in normal operation	VDD=3.6V VM=0V		0.7	1	μA
Ipd	Current consumption in power down	VDD=2.0V VM float		1	10	nA
VM Internal Resistance						
Rvmd	Internal resistance between VM and VDD	VDD=2.0V VM float		300		kΩ
Rvms	Internal resistance between VM and GND	VDD=3.6V VM=1.0V		100		kΩ
Power Mosfet On-resistance						
Rdson	Equivalent mosfet on-resistance	VDD=3.6V IVM=0.2A		100		mΩ
Over Temperature Protection						
Tshd+	Over-temperature protection			130		°C
Tshd-	Over-temperature recovery			110		°C
Detection Delay Time						
Tvoc	Over-charge voltage detection delay time		70	100	150	ms
Tvod	Over-discharge voltage detection delay time		60	80	120	ms
Tioc	Over-charge current detection delay time	VDD=3.6V	6	12	18	ms
Tiod	Over-discharge current detection delay time	VDD=3.6V	5	10	15	ms
Tshort	Load short detection delay time	VDD=3.6V	130	180	230	μs

4 Functional Description

4.1 Overview

AXBM20341x monitors the voltage and current of a battery and provides high accuracy protection for:

- Over-charge voltage
- Over-discharge voltage
- Over-charge current
- Over-discharge current
- Short circuit conditions by disconnecting the battery from the load or charger.

These functions are required in order to operate the battery cell within specified limits. The device requires only one external capacitor. The power mosfet is integrated and its R_{dson} is as low as $100\text{m}\Omega$ (typical).

4.2 Normal Operating Mode

If no exceptional condition is detected, charging and discharging can be carried out freely. This condition is called normal operating mode.

4.3 Over-charge Condition

When the battery voltage becomes higher than the over-charge detection voltage (V_{oc}) during charging under normal condition and, the state continues for the over-charge detection delay time (T_{voc}) or longer, AXBM20341x will turn off the charging control mosfet to stop charging. This condition is called over-charge condition.

The over-charge condition is released in the following two cases:

1. When the battery voltage drops below the over-charge release voltage (V_{ocr}), AXBM20341x will turn on the charging control mosfet and return to normal condition.
2. When a load is connected and discharging starts, AXBM20341x will turn on the charging control mosfet and return to normal condition.

4.4 Over-discharge Condition

When the battery voltage drops below the over-discharge detection voltage (V_{od}) during discharging under normal condition and, it continues for the over-discharge detection delay time (T_{vod}) or longer, AXBM20341x will turn off the discharging control mosfet and stop discharging. This condition is called over-discharge condition.

After the discharging control mosfet being turned off, VM pin will be pulled up by the resistor R_{vmd} between VM and VDD within AXBM20341x. 1.5s later, AXBM20341x will go into power-down mode with current (I_{pd}) reduced to 1nA.

This condition is called power-down condition. The VM and VDD pins are shorted by R_{vmd} under the over-discharge and power-down conditions.

The power-down condition is released when a charger is connected and the potential difference between VM and VDD becomes 1.3V (typ) or higher (load short detection voltage). During this time, the mosfet is still off.

When the battery voltage reaches the over-discharge release voltage (V_{odr}) or higher, AXBM20341x will turn on the mosfet and change to normal condition from the over-discharge condition.

4.5 Over-current Condition

When the discharging current becomes equal to or higher than a specified value (the VM pin voltage is equal to or higher than the over-current detection voltage) during discharging under normal condition and, the state continues for the over-current detection delay time or longer, AXBM20341x will turn off the discharging control mosfet so as to stop discharging. This condition is called over-current condition. (The over-current includes over-current or load short) The VM and GND pins are shorted internally by Rvms under over-current condition. When a load is connected, the VM pin voltage is equal to VDD voltage due to the load. The over-current condition returns to normal condition when the load is released and the impedance between Pack+ and Pack- pins becomes higher than the automatic recoverable impedance. When the load is removed, the VM pin goes back to GND potential since it is shorted to GND via Rvms. Detecting that the VM pin potential is lower than the over-current detection voltage (Voc), AXBM20341x returns to normal condition.

4.6 Abnormal Charge Current Detection

If the VM pin voltage drops below the charger detection voltage (Vcha) during charging under the normal condition and, it continues for the delay time of Tioc or longer, AXBM20341x will turn off the charging control mosfet and stop charging. This action is called abnormal charge current detection.

Abnormal charge current detection starts working when the discharging control mosfet is turned on and the VM pin voltage drops below the charger detection voltage (Vcha). When an abnormal charge current flows into a battery in over-discharge condition, AXBM20341x will turn off the charging control mosfet and stop charging.

Abnormal charge current detection is released when the voltage difference between the VM pin and GND pin becomes lower than the charger detection voltage (Vcha) by separating the charger. Since the 0V battery charging function has higher priority than the abnormal charge current detection function, abnormal charge current may not be detected by the 0V battery charging function while the battery voltage is low.

4.7 Load Short Condition

If voltage of VM pin is equal or below short protection voltage (Vshort), AXBM20341x will stop discharging and battery will be disconnected from load. The maximum delay time to switch off the current is Tshort. This status is released when VM voltage is higher than the short protection voltage (Vshort), such as when disconnecting the load.

Precaution:

If < 50mAh Li-Battery is shorted, the voltage of battery may be pulled down to 0V~1V quickly so that the short-circuiting protection logic may not work properly. Increasing the R1 and C1 to 330Ω and 1μF respectively can solve this problem.

4.8 Delay Circuits

The detection delay time for over-discharge current and load short-circuiting starts when over-discharge current is detected. As soon as over-discharge current or load short is detected over detection delay, AXBM20341x will stop discharging. When battery voltage falls below over-discharge detection voltage due to over-discharge current, AXBM20341x will stop discharging by over-discharge current detection. In this case the recovery of battery voltage is so slow that if battery voltage after over-discharge voltage detection delay time is still lower than over-discharge detection voltage, AXBM20341x will shift to power-down mode.

4.9 0V Battery Charging Function

This function enables the charging of a connected battery whose voltage is 0V due to self-discharge. When a charger having 0V battery starts charging charger voltage (V_{0cha}) or higher is connected between Pack+ and Pack- pins, the charging control mosfet gate is fixed to VDD potential. When the voltage between the gate and the source of the charging control mosfet becomes equal to or higher than the turn-on voltage by the charger voltage, the charging control mosfet is turned on to start charging. At this time, the discharging control mosfet is turned off and the charging current flows through the internal parasitic diode in the discharging control mosfet. If the battery voltage becomes equal to or higher than the over-discharge release voltage (V_{odr}), normal condition returns.

Note:

- (1) Some battery providers do not recommend charging of completely discharged batteries. Please refer to battery providers before the selection of 0V battery charging function.
- (2) When a battery is connected to the device for the first time, the device may not enter the normal condition in which discharging is possible. In this case, set the VM pin voltage equal to the GND voltage (short the VM and GND pins or connect a charger) to enter the normal condition.

4.10 Timing Diagrams

Figure 4 Over-charge and Over-discharge Voltage Detection

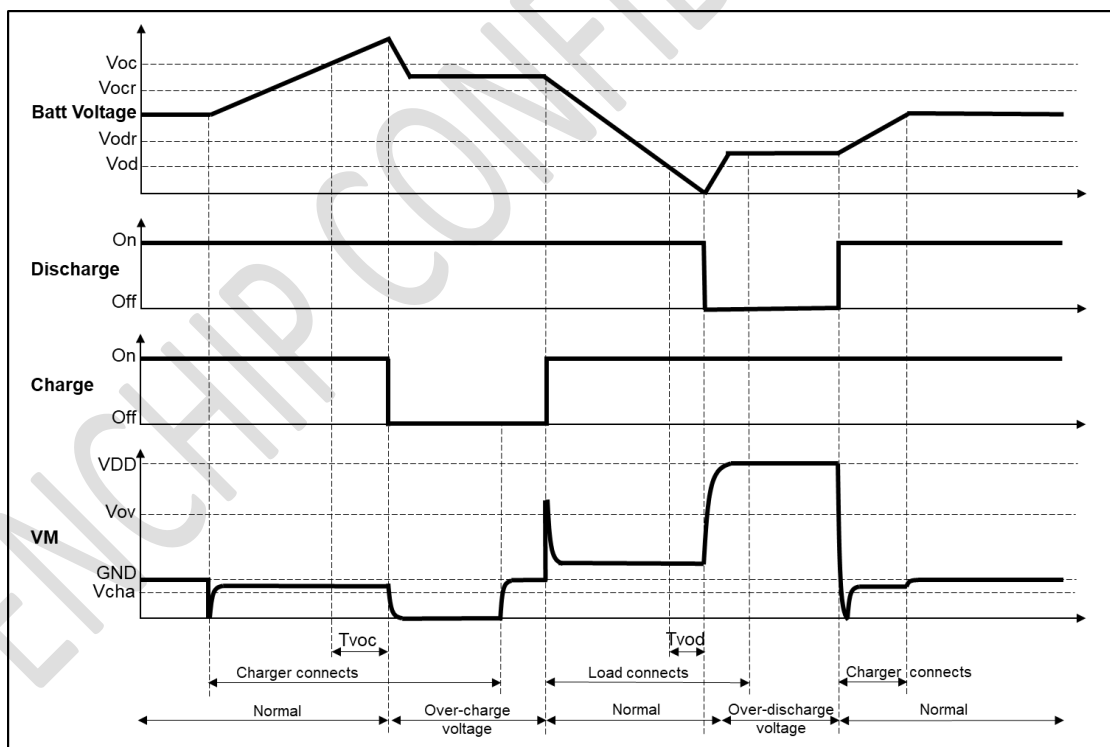

Figure 5 Over-discharge Current Detection

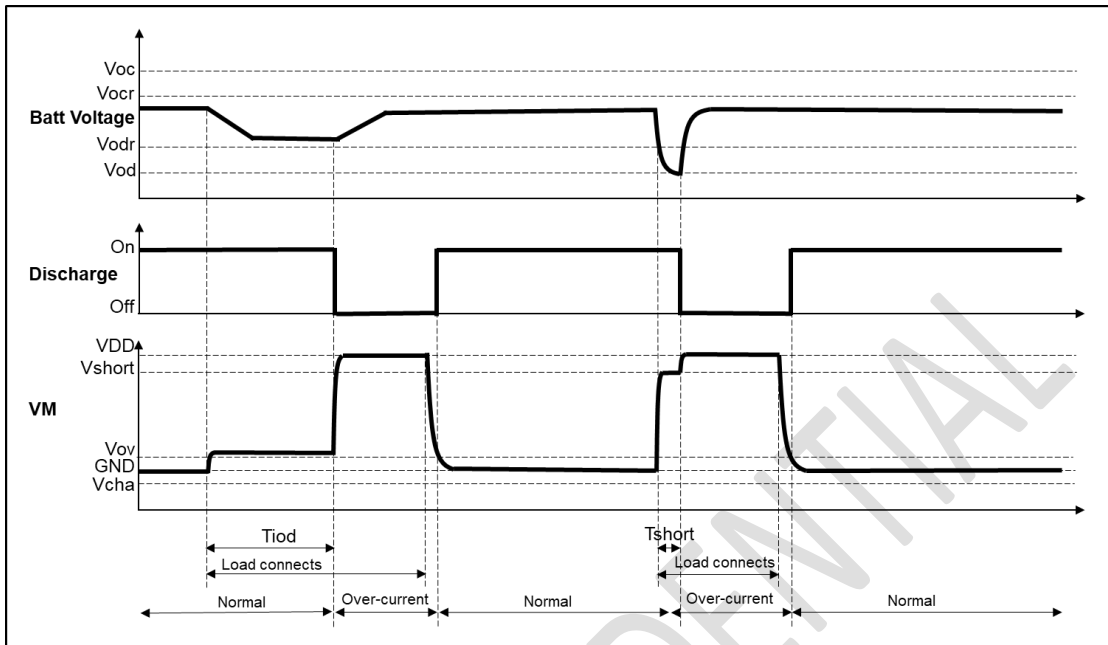

Figure 6 Charger Detection

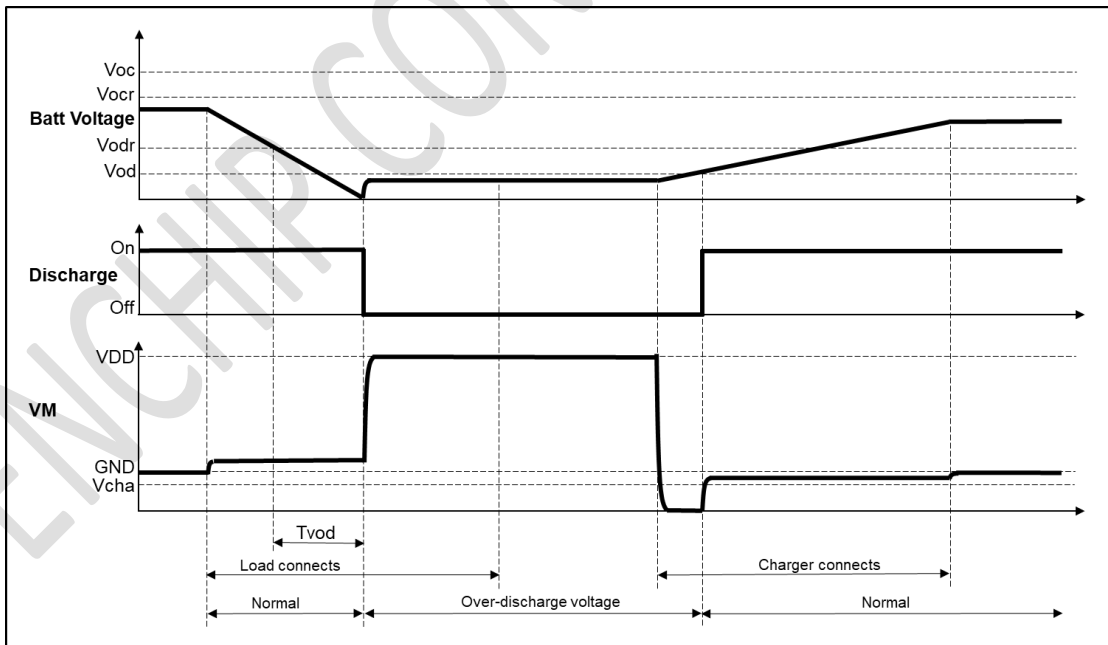
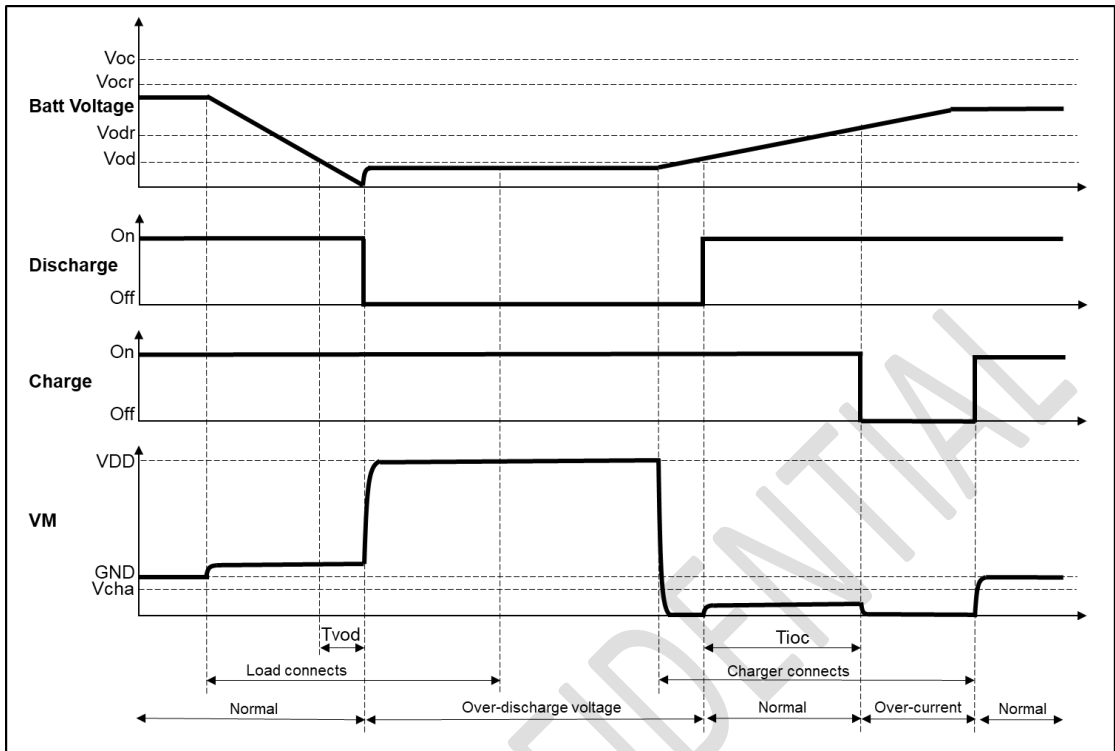

Figure 7 Abnormal Charger Detection



5 Package Information

5.1 Package Outline Dimensions

Figure 8 DFN4 EPAD 1.0 x 1.0 x 0.37 mm Mechanical Data and Package Dimensions

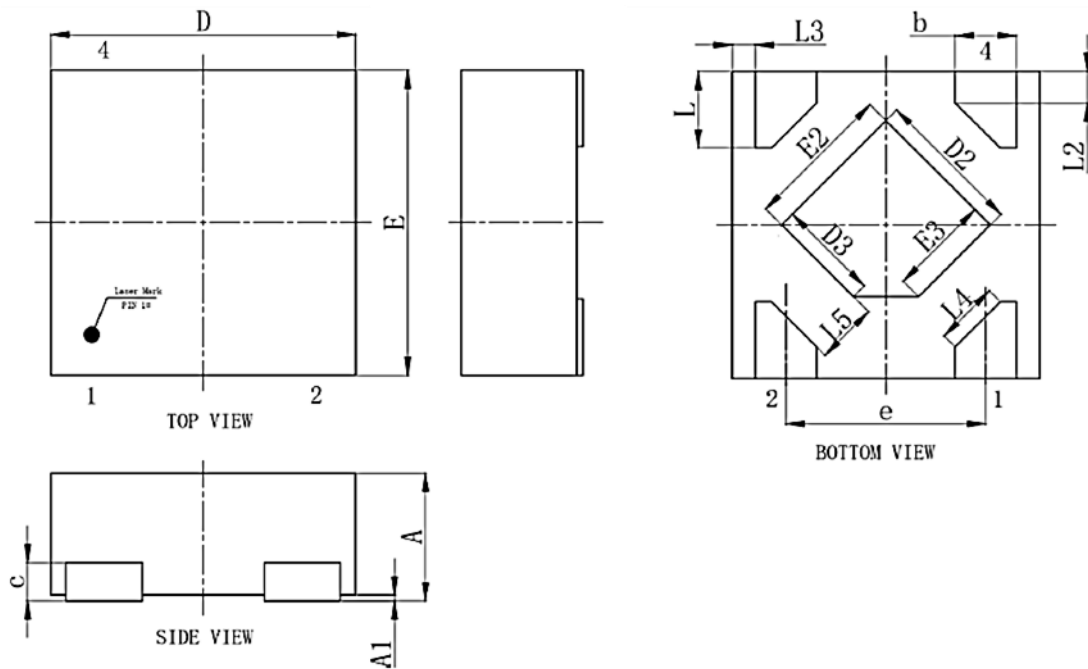

SYMBOL	MILLIMETER		
	MIN	NOM	MAX
A	0.35	-	0.40
A1	0.00	0.02	0.05
b	0.15	0.20	0.25
c	0.127REF		
D	0.95	1.00	1.05
D2	0.38	0.48	0.58
D3	0.23	0.33	0.43
e	0.65BSC		

SYMBOL	MILLIMETER		
	MIN	NOM	MAX
E	0.95	1.00	1.05
E2	0.38	0.48	0.58
E3	0.23	0.33	0.43
L	0.20	0.25	0.30
L2	0.103REF		
L3	0.075REF		
L4	0.208REF		
L5	0.200REF		

5.2 Package Marking Information

Figure 9 DFN4 EPAD 1.0 x 1.0 x 0.37 mm Marking Information

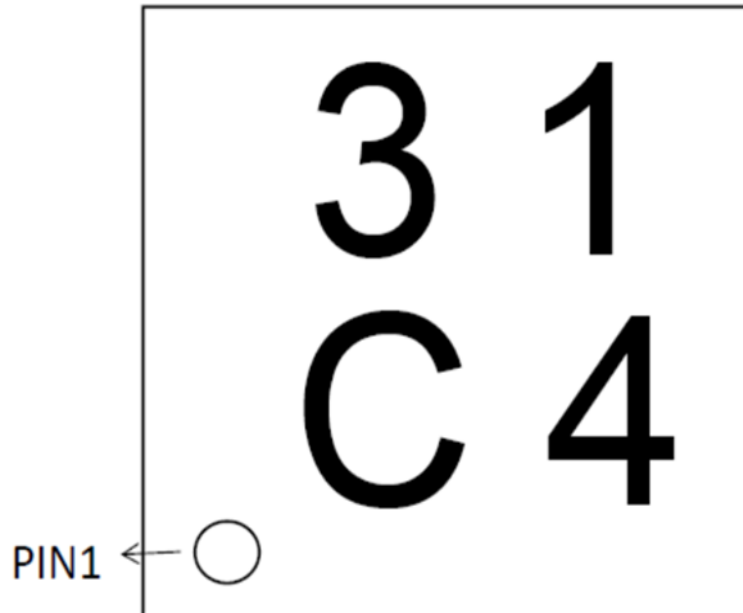

Laser mark circle to indicate pin 1

2 lines of alphanumeric coding:

Line 1: "31" to indicate AXBM20341 device

Line 2: 1st character to indicate device options

"C" = AXBM20341A with 4.28V V_{OC}

"Z" = AXBM20341B with 4.42V V_{OC}

2nd character to indicate production month number: 1,2,3,4,5,6,7,8,9,A,C,D

6 Packing Information

Figure 10 Reel Packing Information

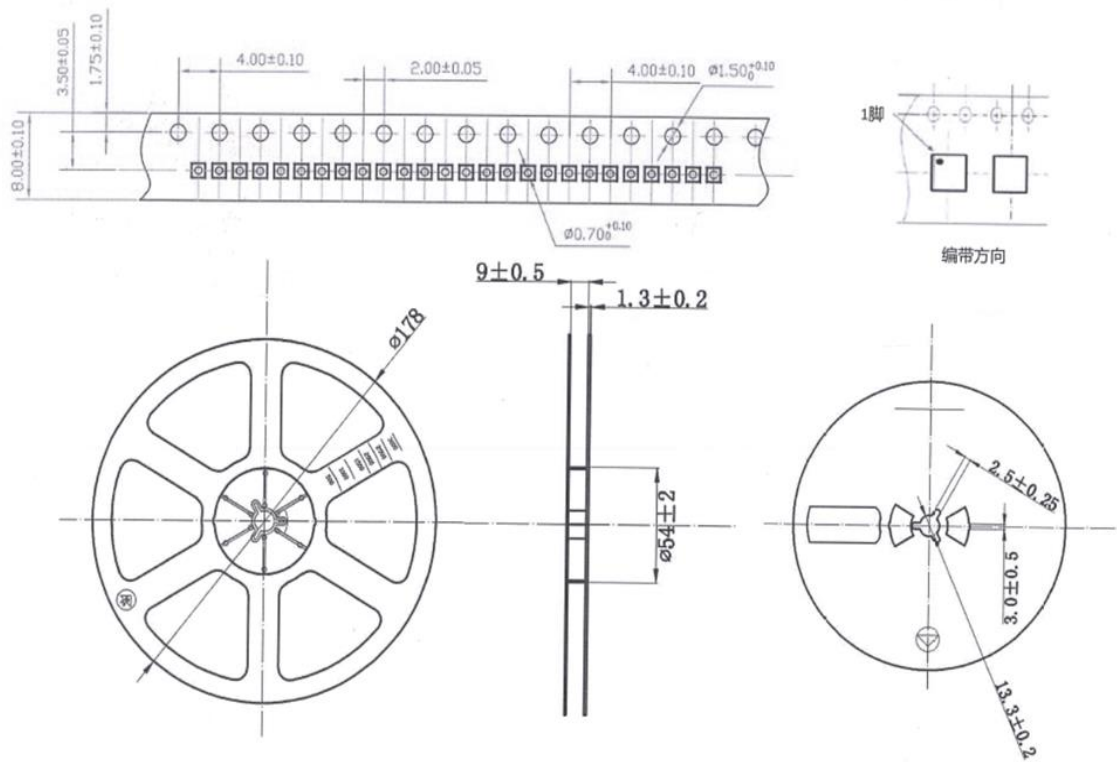

7 Revision History

Table 7 Document Revision History

Date	Version	Description
Apr 2021	1.00	First version.
Aug 2021	1.10	Added package marking information and reel packing information.