



XT25W32B

Quad IO Serial NOR Flash Datasheet

芯天下技术股份有限公司

XTX Technology Inc.

Tel: (86 755) 28229862

Fax: (86 755) 28229847

Web Site: <http://www.xtxtech.com/>

Technical Contact: fae@xtxtech.com

* Information furnished is believed to be accurate and reliable. However, XTX Technology Inc. assumes no responsibility for the consequences of use of such information or for any infringement of patents of other rights of third parties which may result from its use. No license is granted by implication or otherwise under any patent rights of XTX Technology Inc. Specifications mentioned in this publication are subject to change without notice. This publication supersedes and replaces all information previously supplied. XTX Technology Inc. products are not authorized for use as critical components in life support devices or systems without express written approval of XTX Technology Inc. The XTX logo is a registered trademark of XTX Technology Inc. All other names are the property of their respective own.

Serial NOR Flash Memory

Wide Range VCC Multi I/O with 4KB, 32KB & 64KB Sector/Block Erase

- **32M -bit Serial Flash**
 - 4096K-byte
 - 256 bytes per programmable page
- **Support SFDP & Unique ID**
- **Standard, Dual, Quad SPI**
 - Standard SPI: SCLK, CS#, SI, SO, WP#, HOLD#
 - Dual SPI: SCLK, CS#, IO0, IO1, WP#, HOLD#
 - Quad SPI: SCLK, CS#, IO0, IO1, IO2, IO3
 - QPI: SCLK, CS#, IO0, IO1, IO2, IO3
- **Flexible Architecture**
 - Sector of 4K-byte
 - Block of 32/64k-byte
- **Advanced security Features**
 - 4*256-Byte Security Registers With OTP Lock
- **Software/Hardware Write Protection**
 - Write protect all/portion of memory via software
 - Enable/Disable protection with WP# Pin
 - Top or Bottom, Sector or Block selection
- **Package Options**
 - See 1.1 Available Ordering OPN
 - All Pb-free packages are compliant RoHS, Halogen-Free and REACH.
- **Temperature Range & Moisture Sensitivity Level**
 - Industrial Level Temperature. (-40°C to +85°C), MSL3
- **Low Power Consumption**
 - 12uA typical standby current
 - 0.1uA typical power down current
- **Single Power Supply Voltage:**
 - 1.65~3.60V
- **Minimum 100,000 Program/Erase Cycle**
- **High Speed Clock Frequency**
 - 80MHz for fast read with 30PF load
 - Dual I/O Data transfer up to 160Mbits/s
 - Quad I/O Data transfer up to 320Mbits/s
 - QPI Mode Data transfer up to 180Mbits/s
 - Continuous Read With 8/16/32/64-byte Wrap
- **Program/Erase Speed**
 - Page Program time: 2ms typical
 - Sector Erase time: 100ms typical
 - Block Erase time: 0.5/0.7s typical
 - Chip Erase time: 38s typical

CONTENTS

1. GENERAL DESCRIPTION	5
1.1. AVAILABLE ORDERING OPN	5
1.2. CONNECTION DIAGRAM	6
1.3. PIN DESCRIPTION	6
1.4. BLOCK DIAGRAM	7
2. MEMORY ORGANIZATION	8
3. DEVICE OPERATION	9
4. DATA PROTECTION	10
5. STATUS REGISTER	13
6. COMMANDS DESCRIPTION	15
6.1. WRITE ENABLE (WREN) (06H)	19
6.2. WRITE ENABLE FOR VOLATILE STATUS REGISTER (50H)	19
6.3. WRITE DISABLE (WRDI) (04H)	21
6.4. READ STATUS REGISTER (RDSR) (05H OR 35H)	22
6.5. WRITE STATUS REGISTER (WRSR) (01H)	23
6.6. READ DATA BYTES (READ) (03H)	24
6.7. READ DATA BYTES AT HIGHER SPEED (FAST READ) (0BH)	24
6.8. DUAL OUTPUT FAST READ (3BH)	25
6.9. QUAD OUTPUT FAST READ (6BH)	27
6.10. DUAL I/O FAST READ (BBH)	27
6.11. QUAD I/O FAST READ (EBH)	29
6.12. QUAD I/O WORD FAST READ (E7H)	31
6.13. SET BURST WITH WRAP (77H)	33
6.14. PAGE PROGRAM (PP) (02H)	34
6.15. QUAD PAGE PROGRAM (QPP) (32H)	35
6.16. SECTOR ERASE (SE) (20H)	36
6.17. 32KB BLOCK ERASE (BE) (52H)	37
6.18. 64KB BLOCK ERASE (BE) (D8H)	38
6.19. CHIP ERASE (CE) (60/C7H)	39
6.20. DEEP POWER-DOWN (DP) (B9H)	41
6.21. RELEASE FROM DEEP POWER-DOWN AND READ DEVICE ID (RDI) (ABH)	42
6.22. READ MANUFACTURE ID/ DEVICE ID (REMS) (90H)	44
6.23. READ MANUFACTURE ID/ DEVICE ID DUAL I/O (92H)	45
6.24. READ MANUFACTURE ID/ DEVICE ID QUAD I/O (94H)	46
6.25. READ IDENTIFICATION (RDID) (9FH)	46
6.26. ERASE SECURITY REGISTERS (44H)	47
6.27. PROGRAM SECURITY REGISTERS (42H)	48
6.28. READ SECURITY REGISTERS (48H)	49
6.29. SET READ PARAMETERS (COH)	50
6.30. BURST READ WITH WRAP (0CH)	51
6.31. ENABLE QPI (38H)	51
6.32. CONTINUOUS READ MODE RESET (CRMR) (FFH)/ DISABLE QPI (FFH)	52
6.33. ENABLE RESET (66H) AND RESET (99H)	53
6.34. READ SERIAL FLASH DISCOVERABLE PARAMETER (5AH)	54
6.35. READ UNIQUE ID (5AH)	55



7.	ELECTRICAL CHARACTERISTICS.....	60
7.1.	POWER-ON TIMING	60
7.2.	INITIAL DELIVERY STATE	60
7.3.	DATA RETENTION AND ENDURANCE	60
7.4.	LATCH UP CHARACTERISTICS	60
7.5.	ABSOLUTE MAXIMUM RATINGS.....	61
7.6.	CAPACITANCE MEASUREMENT CONDITION	61
7.7.	DC CHARACTERISTICS	62
7.8.	AC CHARACTERISTICS	63
8.	ORDERING INFORMATION.....	66
9.	PACKAGE INFORMATION	67
9.1.	PACKAGE SOP8 150MIL	67
9.2.	PACKAGE SOP8 208MIL	68
9.3.	PACKAGE DFN8 (2x3x0.55) MM	69
9.4.	PACKAGE DFN8 (4x3x0.55) MM	70
10.	REVISION HISTORY.....	71

1. GENERAL DESCRIPTION

The XT25W32B (32M-bit) Serial flash supports the standard Serial Peripheral Interface (SPI), and supports the Dual/Quad SPI: Serial Clock, Chip Select, Serial Data I/O0 (SI), I/O1 (SO), I/O2 (WP#), and I/O3 (HOLD#). Under 1.65-2.1V, the Single I/O has a data transferred rate of 56Mbits/s, the Dual I/O has a data transferred rate of 112Mbits/s, Quad I/O is 224Mbits/s. Under 2.1V-3.6V, the Single I/O has a data transferred rate of 80Mbits/s, the Dual I/O has a data transferred rate of 160Mbits/s, Quad I/O is 320Mbits/s.

1.1. Available Ordering OPN

OPN	Package Type	Package Carrier
XT25W32BSOIGU	SO8 150mil	Tube
XT25W32BSOIGT	SO8 150mil	Tape & Reel
XT25W32BSSIGU	SO8 208mil	Tube
XT25W32BSSIGT	SO8 208mil	Tape & Reel
XT25W32BWOIGT	WSON8 6x5mm	Tape & Reel
XT25W32BDFIGT	DFN8 2x3x0.55 mm	Tape & Reel
XT25W32BDXIGT	DFN8 4x3x0.55 mm	Tape & Reel

1.2. Connection Diagram

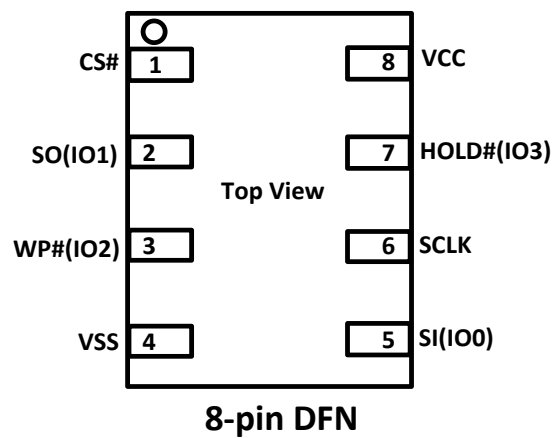
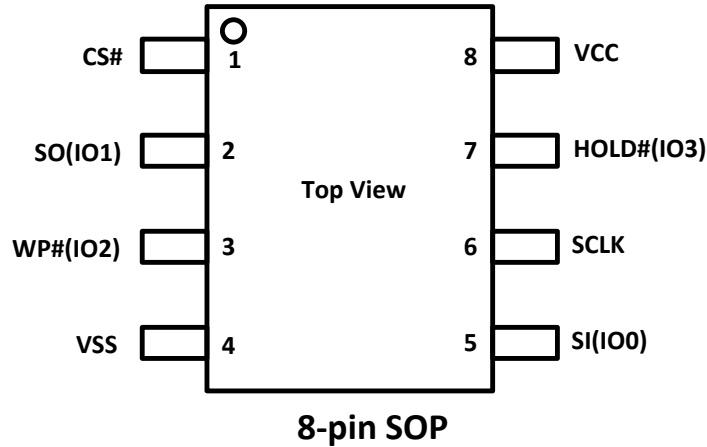

1.3. Pin Description

Pin Name	I/O	Description
CS#	I	Chip Select Input
SO (IO1)	I/O	Data Output (Data Input Output 1)
WP# (IO2)	I/O	Write Protect Input (Data Input Output 2)
VSS		Ground
SI (IO0)	I/O	Data Input (Data Input Output 0)
SCLK	I	Serial Clock Input
HOLD# (IO3)	I/O	Hold Input (Data Input Output 3)
VCC		Power Supply

Notes:

- IO0 and IO1 are used for Standard and Dual SPI instructions
- IO0 – IO3 are used for Quad SPI instructions, WP# & HOLD# functions are only available for Standard/Dual SPI.

1.4. Block Diagram

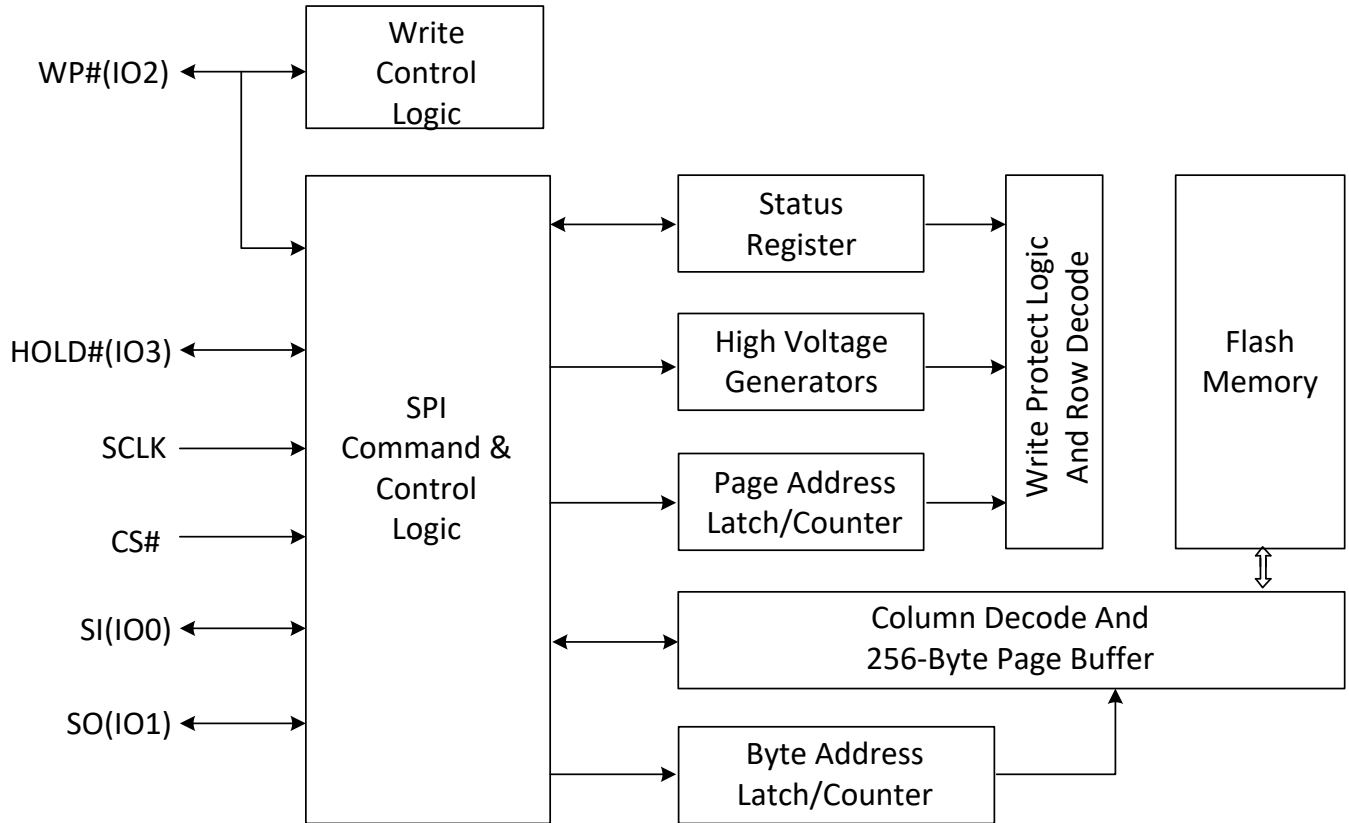

2. MEMORY ORGANIZATION

XT25W32B

Each Device has	Each block has	Each sector has	Each page has	Remark
4M	64K/32K	4K	256	bytes
16K	256/128	16	-	pages
1K	16/8	-	-	sectors
64/128	-	-	-	blocks

UNIFORM BLOCK SECTOR ARCHITECTURE

XT25W32B 64K Bytes Block Sector Architecture

Block	Sector	Address range	
63	1023	3FF000H	3FFFFFFH

	1008	3F0000H	3F0FFFFH
62	1007	3EF000H	3EFFFFFFH

	992	3E0000H	3E0FFFFH
.....

.....

2	47	02F000H	02FFFFFFH

	32	020000H	020FFFFH
1	31	01F000H	01FFFFFFH

	16	010000H	010FFFFH
0	15	00F000H	00FFFFFFH

	0	000000H	000FFFFH

3. DEVICE OPERATION

SPI Mode

Standard SPI

The XT25W32B features a serial peripheral interface on 4 signals bus: Serial Clock (SCLK), Chip Select (CS#), Serial Data Input (SI) and Serial Data Output (SO). Both SPI bus mode 0 and 3 are supported. Input data is latched on the rising edge of SCLK and data shifts out on the falling edge of SCLK.

Note: “WP#” & “HOLD#” pin require external pull-up.

Dual SPI

The XT25W32B supports Dual SPI operation when using the “Dual Output Fast Read” and “Dual I/O Fast Read” (3BH and BBH) commands. These commands allow data to be transferred to or from the device at two times the rate of the standard SPI. When using the Dual SPI command the SI and SO pins become bidirectional I/O pins: IO0 and IO1.

Note: “WP#” & “HOLD#” pin require external pull-up.

Quad SPI

The XT25W32B supports Quad SPI operation when using the “Quad Output Fast Read”, “Quad I/O Fast Read”, “Quad I/O Word Fast Read” (6BH, EBH, E7H) commands. These commands allow data to be transferred to or from the device at four times the rate of the standard SPI. When using the Quad SPI command the SI and SO pins become bidirectional I/O pins: IO0 and IO1, and WP# and HOLD# pins become IO2 and IO3. Quad SPI commands require the non-volatile Quad Enable bit (QE) in Status Register to be set.

QPI

The XT25W32B supports Quad Peripheral Interface (QPI) operations only when the device is switched from Standard/Dual/Quad SPI mode to QPI mode using the “Enable the QPI (38H)” command. The QPI mode utilizes all four IO pins to input the command code. Standard/Dual/Quad SPI mode and QPI mode are exclusive. Only one mode can be active at any given times. “Enable the QPI (38H)” and “Disable the QPI (FFH)” commands are used to switch between these two modes. Upon power-up and after software reset using “Reset (99H)” command, the default state of the device is Standard/Dual/Quad SPI mode. The QPI mode requires the non-volatile Quad Enable bit (QE) in Status Register to be set.

Hold

The HOLD# signal goes low to stop any serial communications with the device, but doesn't stop the operation of write status register, programming, or erasing in progress.

The operation of HOLD, need CS# keep low, and starts on falling edge of the HOLD# signal, with SCLK signal being low (if SCLK is not being low, HOLD operation will not start until SCLK being low). The HOLD condition ends on rising edge of HOLD# signal with SCLK being low (If SCLK is not being low, HOLD operation will not end until SCLK being low).

Both SI and SCLK don't care during the HOLD operation, if CS# drives high during HOLD operation, it will reset the internal logic of the device. To re-start communication with chip, the HOLD# must be at high and then CS# must be at low.

Figure1. Hold Condition

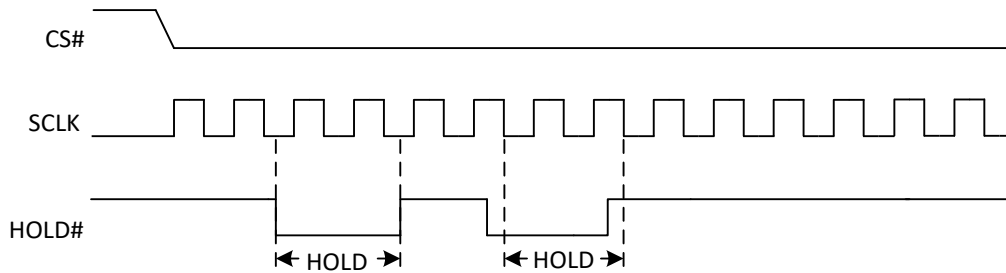

4. DATA PROTECTION

The XT25W32B provide the following data protection methods:

- Write Enable (WREN) command: The WREN command is set the Write Enable Latch bit (WEL). The WEL bit will return to reset by the following situation:
 - Power-Up
 - Write Disable (WRDI)
 - Write Status Register (WRSR)
 - Page Program (PP)
 - Sector Erase (SE) / Block Erase (BE) / Chip Erase (CE)
 - Erase Security Register / Program Security Register
- Software Protection Mode: The Block Protect (BP4, BP3, BP2, BP1, BP0) bits and CMP bit define the section of the memory array that can be read but not change.
- Hardware Protection Mode: WP# goes low to prevent writing status register.
- Deep Power-Down Mode: In Deep Power-Down Mode, all commands are ignored except the Release from Deep Power-Down Mode command (ABH) and software reset (66H+99H).

Table1.0 XT25W32B Protected area size (CMP=0)

Status Register Content					Memory Content			
BP4	BP3	BP2	BP1	BP0	Blocks	Addresses	Density	Portion
X	X	0	0	0	NONE	NONE	NONE	NONE
0	0	0	0	1	63	3F0000H-3FFFFFFH	64KB	Upper 1/64
0	0	0	1	0	62 to 63	3E0000H-3FFFFFFH	128KB	Upper 1/32
0	0	0	1	1	60 to 63	3C0000H-3FFFFFFH	256KB	Upper 1/16
0	0	1	0	0	56 to 63	380000H-3FFFFFFH	512KB	Upper 1/8
0	0	1	0	1	48 to 63	300000H-3FFFFFFH	1MB	Upper 1/4
0	0	1	1	0	32 to 63	200000H-3FFFFFFH	2MB	Upper 1/2
0	1	0	0	1	0	000000H-00FFFFH	64KB	Lower 1/64
0	1	0	1	0	0 to 1	000000H-01FFFFH	128KB	Lower 1/32
0	1	0	1	1	0 to 3	000000H-03FFFFH	256KB	Lower 1/16
0	1	1	0	0	0 to 7	000000H-07FFFFH	512KB	Lower 1/8
0	1	1	0	1	0 to 15	000000H-0FFFFFFH	1MB	Lower 1/4
0	1	1	1	0	0 to 31	000000H-1FFFFFFH	2MB	Lower 1/2
X	X	1	1	1	0 to 63	000000H-3FFFFFFH	4MB	ALL
1	0	0	0	1	63	3FF000H-3FFFFFFH	4KB	Top Block
1	0	0	1	0	63	3FE000H-3FFFFFFH	8KB	Top Block
1	0	0	1	1	63	3FC000H-3FFFFFFH	16KB	Top Block
1	0	1	0	X	63	3F8000H-3FFFFFFH	32KB	Top Block
1	0	1	1	0	63	3F8000H-3FFFFFFH	32KB	Top Block
1	1	0	0	1	0	000000H-000FFFH	4KB	Bottom Block
1	1	0	1	0	0	000000H-001FFFH	8KB	Bottom Block
1	1	0	1	1	0	000000H-003FFFH	16KB	Bottom Block
1	1	1	0	X	0	000000H-007FFFH	32KB	Bottom Block
1	1	1	1	0	0	000000H-007FFFH	32KB	Bottom Block

Table1.1 XT25W32B Protected area size (CMP=1)

Status Register Content					Memory Content			
BP4	BP3	BP2	BP1	BP0	Blocks	Addresses	Density	Portion
X	X	0	0	0	ALL	000000H-3FFFFFFH	4MB	ALL
0	0	0	0	1	0 to 62	000000H-3EFFFFFFH	4032KB	Lower 63/64
0	0	0	1	0	0 to 61	000000H-3DFFFFFFH	3968KB	Lower 31/32
0	0	0	1	1	0 to 59	000000H-3BFFFFFFH	3840KB	Lower 15/16
0	0	1	0	0	0 to 55	000000H-37FFFFFFH	3584KB	Lower 7/8
0	0	1	0	1	0 to 47	000000H-2FFFFFFH	3MB	Lower 3/4
0	0	1	1	0	0 to 31	000000H-1FFFFFFH	2MB	Lower 1/2
0	1	0	0	1	1 to 63	000000H-00FFFFFFH	4032KB	Upper 63/64
0	1	0	1	0	2 to 63	000000H-01FFFFFFH	3968KB	Upper 31/32
0	1	0	1	1	4 to 63	000000H-03FFFFFFH	3840KB	Upper 15/16
0	1	1	0	0	8 to 63	000000H-07FFFFFFH	3584KB	Upper 7/8
0	1	1	0	1	16 to 63	000000H-0FFFFFFH	3MB	Upper 3/4
0	1	1	1	0	32 to 63	000000H-1FFFFFFH	2MB	Upper 1/2
X	X	1	1	1	NONE	NONE	NONE	NONE
1	0	0	0	1	0 to 63	000000H-3FEFFFFFFH	4092KB	L-1023/1024
1	0	0	1	0	0 to 63	000000H-3FDFFFFFFH	4088KB	L-511/512
1	0	0	1	1	0 to 63	000000H-3FBFFFFFFH	4080KB	L-255/256
1	0	1	0	X	0 to 63	000000H-3F7FFFFFFH	4064KB	L-127/128
1	0	1	1	0	0 to 63	000000H-3F7FFFFFFH	4064KB	L-127/128
1	1	0	0	1	0 to 63	001000H-3FFFFFFH	4092KB	U-1023/1024
1	1	0	1	0	0 to 63	002000H-3FFFFFFH	4088KB	U-511/512
1	1	0	1	1	0 to 63	004000H-3FFFFFFH	4080KB	U-255/256
1	1	1	0	X	0 to 63	008000H-3FFFFFFH	4064KB	U-127/128
1	1	1	1	0	0 to 63	008000H-3FFFFFFH	4064KB	U-127/128

5. STATUS REGISTER

S15	S14	S13	S12	S11	S10	S9	S8
Reserved	CMP	Reserved	Reserved	Reserved	LB	QE	SRP1

S7	S6	S5	S4	S3	S2	S1	S0
SRP0	BP4	BP3	BP2	BP1	BPO	WEL	WIP

The status and control bits of the Status Register are as follows:

WIP bit.

The Write In Progress (WIP) bit indicates whether the memory is busy in program/erase/write status register progress. When WIP bit sets to 1, means the device is busy in program/erase/write status register progress, when WIP bit sets 0, means the device is not in program/erase/write status register progress.

WEL bit.

The Write Enable Latch (WEL) bit indicates the status of the internal Write Enable Latch. When set to 1 the internal Write Enable Latch is set, when set to 0 the internal Write Enable Latch is reset and no Write Status Register, Program or Erase command is accepted.

BP4, BP3, BP2, BP1, BPO bits.

The Block Protect (BP4, BP3, BP2, BP1, BPO) bits are non-volatile. They define the size of the area to be software protected against Program and Erase commands. These bits are written with the Write Status Register (WRSR) command. When the Block Protect (BP4, BP3, BP2, BP1, BPO) bits are set to 1, the relevant memory area (as defined in Table1) becomes protected against Page Program (PP), Sector Erase (SE) and Block Erase (BE) commands. The Block Protect (BP4, BP3, BP2, BP1, BPO) bits can be written provided that the Hardware Protected mode has not been set. The Chip Erase (CE) command is executed if the Block Protect (BP2, BP1, BPO) bits are 0 and CMP=0 or the Block Protect (BP2, BP1, BPO) bits are 1 and CMP=1.

SRP1,SRP0 bits.

The Status Register Protect (SRP1 and SRP0) bits are non-volatile Read/Write bits in the status register. The SRP bits control the method of write protection: software protection, hardware protection, power supply lock-down or one-time programmable protection.

SRP1	SRP0	WP#	Status Register	Description
0	0	X	Software Protected	The Status Register can be written to after a Write Enable command, WEL=1. (Default)
0	1	0	Hardware Protected	WP#=0, the Status Register locked and cannot be written until the next power-up.
0	1	1	Hardware Unprotected	WP#=1, the Status Register is unlocked and can be written to after a Write Enable command, WEL=1.
1	0	X	Power Supply Lock-Down(1)(2)	Status Register is protected and cannot be written to again until the next Power-Down, Power-Up cycle.
1	1	X	One-Time Program(2)	Status Register is permanently protected and cannot be written to.

NOTE:

1. When SRP1, SRP0= (1, 0), a Power-Down, Power-Up cycle will change SRP1, SRP0 to (0, 0) state.
2. This feature is available on special order(XT25W32BxxSx). Please contact XTX for details.

QE bit.

The Quad Enable (QE) bit is a non-volatile Read/Write bit in the Status Register that allows Quad operation. When the QE bit is set to 0 (Default) the WP# pin and HOLD# pin are enable. When the QE bit is set to 1, the Quad IO2 and IO3 pins are enabled. (The QE bit should never be set to 1 during standard SPI or Dual SPI operation if the WP# or HOLD# pins are tied directly to the power supply or ground).

LB bit.

The LB bit is a non-volatile One Time Program (OTP) bit in Status Register (S10) that provide the write protect control and status to the Security Registers. The default state of LB is 0, the security registers are unlocked. LB can be set to 1 using the Write Register instruction. LB is One Time Programmable, once it's set to 1, the Security Registers will become read-only permanently.

CMP bit.

The CMP bit is a non-volatile Read/Write bit in the Status Register (S14). It is used in conjunction with the BP4-BP0 bits to provide more flexibility for the array protection. Please see the Status registers Memory Protection table for details. The default setting is CMP=0.

6. COMMANDS DESCRIPTION

All commands, addresses and data are shifted in and out of the device, beginning with the most significant bit on the first rising edge of SCLK after CS# is driven low. Then, the one-byte command code must be shifted in to the device, most significant bit first on SI, each bit being latched on the rising edges of SCLK.

See Table2, every command sequence starts with a one-byte command code. Depending on the command, this might be followed by address bytes, or by data bytes, or by both or none. CS# must be driven high after the last bit of the command sequence has been shifted in. For the command of Read, Fast Read, Read Status Register or Release from Deep Power-Down, and Read Device ID, the shifted-in command sequence is followed by a data-out sequence. CS# can be driven high after any bit of the data-out sequence is being shifted out.

For the command of Page Program, Sector Erase, Block Erase, Chip Erase, Write Status Register, Write Enable, Write Disable or Deep Power-Down command, CS# must be driven high exactly at a byte boundary, otherwise the command is rejected, and is not executed. That is CS# must be driven high when the number of clock pulses after CS# being driven low is an exact multiple of eight. For Page Program, if at any time the input byte is not a full byte, nothing will happen and WEL will not be reset.

Table 2. Commands

Command Name	Byte1	Byte2	Byte3	Byte4	Byte5	Byte6	n-Bytes
Write Enable	06H						
Write Enable for Volatile Status Register	50H						
Write Disable	04H						
Read Status Register	05H	(S7-S0)					(continuous)
Read Status Register-1	35H	(S15-S8)					(continuous)
Write Status Register	01H	(S7-S0)	(S15-S8)				(continuous)
Read Data	03H	A23-A16	A15-A8	A7-A0	(D7-D0)	(Next byte)	(continuous)
Fast Read	0BH	A23-A16	A15-A8	A7-A0	dummy	(D7-D0)	(continuous)
Dual Output Fast Read	3BH	A23-A16	A15-A8	A7-A0	dummy	(D7-D0)(1)	(continuous)
Dual I/O Fast Read	BBH	A23-A8(2)	M7-M0(2)	(D7-D0)(1)			(continuous)
Quad Output Fast Read	6BH	A23-A16	A15-A8	A7-A0	dummy	(D7-D0)(3)	(continuous)
Quad I/O Fast Read	EBH	A23-A0	M7-M0(4)	Dummy(5)	(D7-D0)(3)		(continuous)
Quad I/O Word Fast Read	E7H	A23-A0	M7-M0(4)	Dummy(6)	(D7-D0)(3)		(continuous)
Continuous Read Reset	FFH						
Page Program	02H	A23-A16	A15-A8	A7-A0	(D7-D0)	(Next byte)	
Quad Page Program	32H	A23-A16	A15-A8	A7-A0	(D7-D0)(3)		
Enable QPI	38H						
Set Burst with Wrap	77H	dummy	dummy	dummy	W6-W4		
Sector Erase	20H	A23-A16	A15-A8	A7-A0			
Block Erase(32KB)	52H	A23-A16	A15-A8	A7-A0			



Block Erase(64KB)	D8H	A23-A16	A15-A8	A7-A0			
Chip Erase	C7/60H						
Deep Power-Down	B9H						
Release From Deep Power-Down, And Read Device ID	ABH	dummy	dummy	dummy	(DID7-DID0)		(continuous)
Release From Deep Power-Down	ABH						
Manufacturer/Device ID	90H	dummy	dummy	00H	(MID7-MID0)	(DID7-DID0)	(continuous)
Manufacturer/Device ID by Dual I/O	92H	A23-A8	A7-A0, M[7:0]	(M7-M0) (ID7-ID0)			(continuous)
Manufacturer/Device ID by Quad I/O	94H	A23-A0, M[7:0]	dummy	(M7-M0) (ID7-ID0)			
Read Serial Flash Discoverable Parameters	5AH	A23-A16	A15-A8	A7-A0	dummy	(D7-D0)	(continuous)
Read Unique ID	5AH	00H	01H	94H	dummy	(D7-D0)	(continuous)
Read Identification	9FH	(MID7-MID0)	(JDID15-JDID8)	(JDID7-JDID0)			(continuous)
Erase Security Register(8)	44H	A23-A16	A15-A8	A7-A0			
Program Security Register(8)	42H	A23-A16	A15-A8	A7-A0	(D7-D0)	(Next byte)	
Read Security Register(8)	48H	A23-A16	A15-A8	A7-A0	dummy	(D7-D0)	
Enable Reset	66H						
Reset	99H						

Table2a. Commands (QPI)

Command Name	Byte1	Byte2	Byte3	Byte4	Byte5	Byte6
Clock Number	(0,1)	(2,3)	(4,5)	(6,7)	(8,9)	(10,11)
Write Enable	06H					
Write Enable for Volatile Status Register	50H					
Write Disable	04H					
Read Status Register	05H	(S7-S0)				
Read Status Register-1	35H	(S15-S8)				
Write Status Register	01H	(S7-S0)	(S15-S8)			
Page Program	02H	A23-A16	A15-A8	A7-A0	(D7-D0)	(Next byte)
Sector Erase	20H	A23-A16	A15-A8	A7-A0		
Block Erase(32KB)	52H	A23-A16	A15-A8	A7-A0		
Block Erase(64KB)	D8H	A23-A16	A15-A8	A7-A0		
Chip Erase	C7/60H					
Deep Power-Down	B9H					
Set Read Parameters	C0H	P7-P0				
Fast Read	0BH	A23-A16	A15-A8	A7-A0	dummy	(D7-D0)
Burst Read with Wrap	0CH	A23-A16	A15-A8	A7-A0	dummy	(D7-D0)
Quad I/O Fast Read	EBH	A23-A0	dummy(5)	(D7-D0)(3)		
Release from Deep Power-Down, And Read Device	ABH	dummy	dummy	dummy * N	(ID7-ID0)	
Manufacturer/Device ID(11)	90H	dummyx2	00H	dummy * N	MID7~MID0	(ID7-ID0)
Disable QPI	FFH					
Enable Reset	66H					
Reset	99H					

NOTE:

1. Dual Output data

$$IO0 = (D6, D4, D2, D0)$$

$$IO1 = (D7, D5, D3, D1)$$

2. Dual Input Address

$$IO0 = A22, A20, A18, A16, A14, A12, A10, A8, A6, A4, A2, A0, M6, M4, M2, M0$$

$$IO1 = A23, A21, A19, A17, A15, A13, A11, A9, A7, A5, A3, A1, M7, M5, M3, M1$$

3. Quad Output Data

$$IO0 = (D4, D0, \dots)$$

$$IO1 = (D5, D1, \dots)$$

$$IO2 = (D6, D2, \dots)$$

$$IO3 = (D7, D3, \dots)$$

4. Quad Input Address

IO0 = A20, A16, A12, A8, A4, A0, M4, M0

IO1 = A21, A17, A13, A9, A5, A1, M5, M1

IO2 = A22, A18, A14, A10, A6, A2, M6, M2

IO3 = A23, A19, A15, A11, A7, A3, M7, M3

5. Quad I/O Fast Read Data

IO0 = (x, x, x, x, D4, D0,...)

IO1 = (x, x, x, x, D5, D1,...)

IO2 = (x, x, x, x, D6, D2,...)

IO3 = (x, x, x, x, D7, D3,...)

6. Quad I/O Word Fast Read Data

IO0 = (x, x, D4, D0,...)

IO1 = (x, x, D5, D1,...)

IO2 = (x, x, D6, D2,...)

IO3 = (x, x, D7, D3,...)

7. Quad I/O Word Fast Read Data: the lowest address bit must be 0.

8. Security Registers Address:

Security Register1: A23-A16=00H, A15-A8=01H, A7-A0= Byte Address;

Security Register2: A23-A16=00H, A15-A8=02H, A7-A0= Byte Address;

Security Register3: A23-A16=00H, A15-A8=03H, A7-A0= Byte Address;

Security Register4: A23-A16=00H, A15-A8=04H, A7-A0= Byte Address.

9. QPI Command, Address, Data input/output format:

CLK# 0 1 2 3 4 5 6 7 8 9 10 11

IO0 = C4, C0, A20, A16, A12, A8, A4, A0, D4, D0, D4, D0

IO1 = C5, C1, A21, A17, A13, A9, A5, A1, D5, D1, D5, D1

IO2 = C6, C2, A22, A18, A14, A10, A6, A2, D6, D2, D6, D2

IO3 = C7, C3, A23, A19, A15, A11, A7, A3, D7, D3, D7, D3

10. QPI mode: Release from Deep Power-Down, And Read Device ID (ABH)

N dummy cycles should be inserted before ID read cycle, refer to C0H command

11. QPI mode: Manufacturer/Device ID (90H)

N dummy cycles should be inserted before ID read cycle, refer to C0H command

Table of ID Definitions:

XT25W32B

Operation Code	MID7-MID0	ID15-ID8	ID7-ID0
9FH	0B	60	16
90H	0B		15
ABH			15

6.1. Write Enable (WREN) (06H)

The Write Enable (WREN) command is for setting the Write Enable Latch (WEL) bit. The Write Enable Latch (WEL) bit must be set prior to every Page Program (PP), Sector Erase (SE), Block Erase (BE), Chip Erase (CE), Erase Security Register, Program Security Register and Write Status Register (WRSR) command. The Write Enable (WREN) command sequence: CS# goes low -> Sending the Write Enable command -> CS# goes high.

Figure2. Write Enable Sequence Diagram

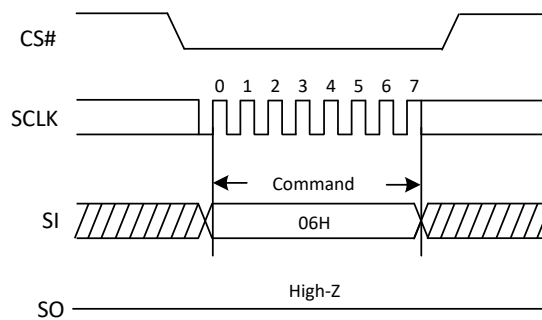
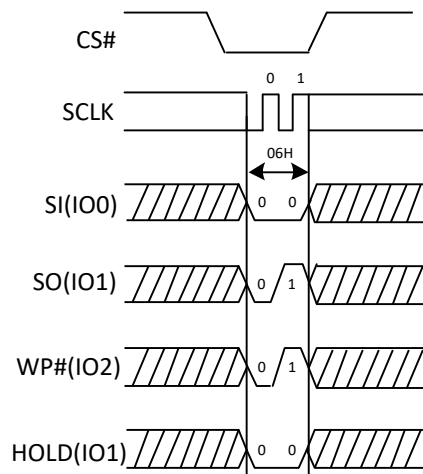

Figure 2a. Write Enable Sequence Diagram (QPI)



6.2. Write Enable for Volatile Status Register (50H)

The non-volatile Status Register bits can also be written to as volatile bits. This gives more flexibility to change the system configuration and memory protection schemes quickly without waiting for the typical non-volatile bit write cycles or affecting the endurance of the Status Register non-volatile bits. The Write Enable for Volatile Status Register command must be issued prior to a Write Status Register command and any other commands can't be inserted between them. Otherwise, Write Enable for Volatile Status Register will be cleared. The Write Enable for Volatile Status Register command will not set the Write Enable Latch bit, it is only valid for the Write Status Register command to change the volatile Status Register bit values.

Figure3. Write Enable for Volatile Status Register Sequence Diagram

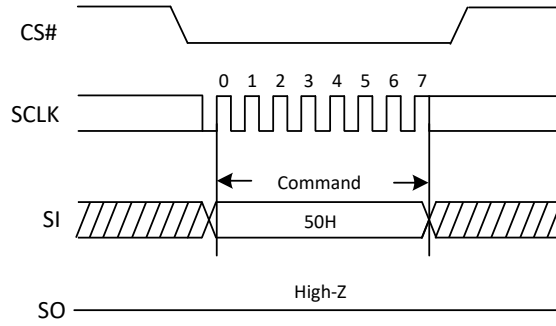
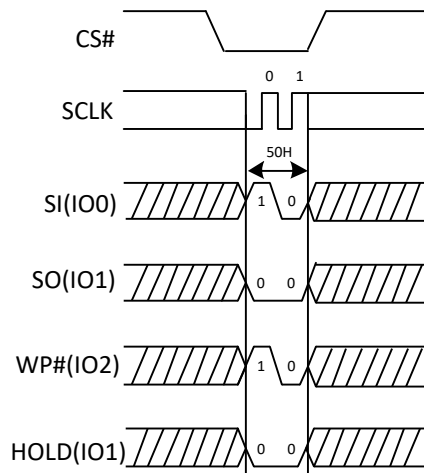

Figure3a. Write Enable for Volatile Status Register Sequence Diagram (QPI)



6.3. Write Disable (WRDI) (04H)

The Write Disable command is for resetting the Write Enable Latch (WEL) bit. The Write Disable command sequence: CS# goes low → sending the Write Disable command → CS# goes high. The WEL bit is reset by following condition: Power-up and upon completion of the Write Status Register, Page Program, Sector Erase, Block Erase and Chip Erase commands.

Figure 4. Write Disable Sequence Diagram

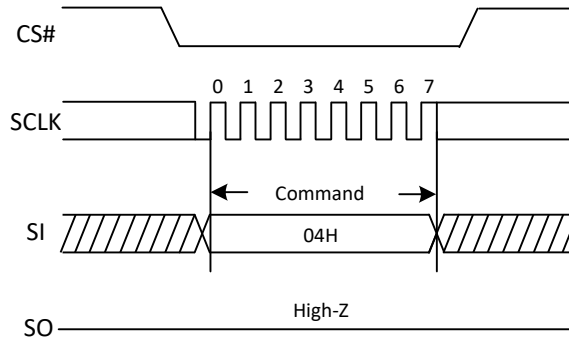
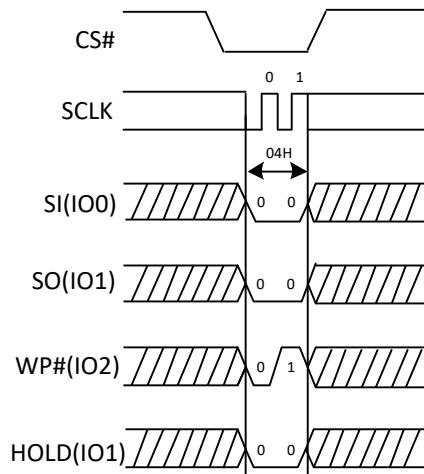

Figure 4a. Write Disable Sequence Diagram (QPI)



6.4. Read Status Register (RDSR) (05H or 35H)

The Read Status Register (RDSR) command is for reading the Status Register. The Status Register can be read at any time, even while a Program, Erase or Write Status Register cycle is in progress. When one of these cycles is in progress, it is recommended to check the Write In Progress (WIP) bit before sending a new command to the device. It is also possible to read the Status Register continuously. For command code "05H", the SO will output Status Register bits S7~S0. The command code "35H", the SO will output Status Register bits S15~S8.

Figure 5. Read Status Register Sequence Diagram

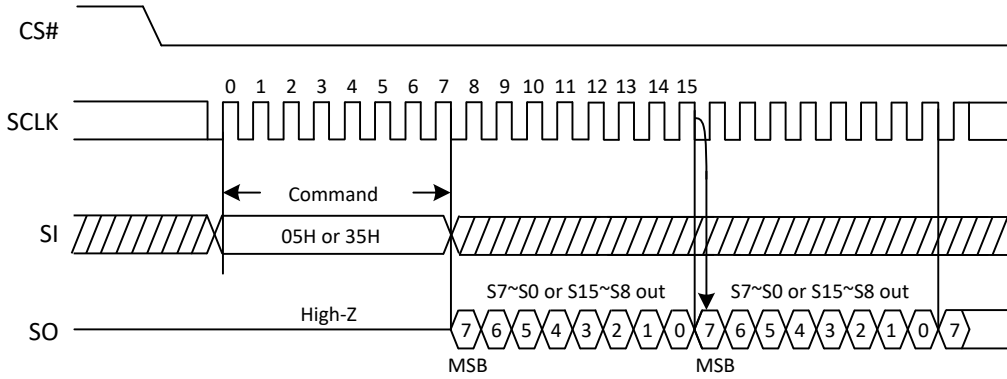
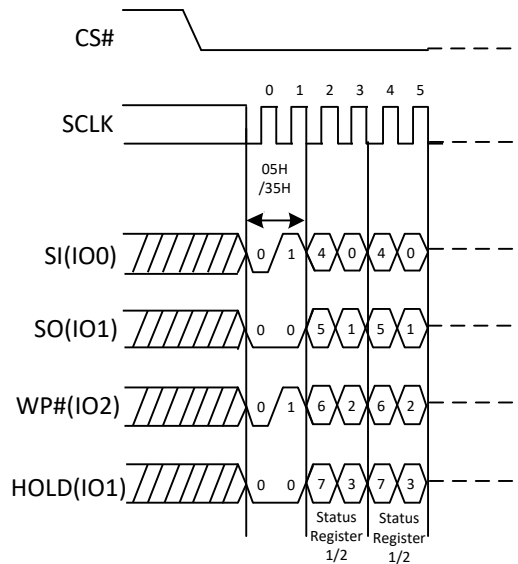

Figure5a. Read Status Register Sequence Diagram (QPI)



6.5. Write Status Register (WRSR) (01H)

The Write Status Register (WRSR) command allows new values to be written to the Status Register. Before it can be accepted, a Write Enable (WREN) command must previously have been executed. After the Write Enable (WREN) command has been decoded and executed, the device sets the Write Enable Latch (WEL).

The Write Status Register (WRSR) command has no effect on S15, S13, S12, S11, S1 and S0 of the Status Register. CS# must be driven high after the eighth or sixteen bit of the data byte has been latched in. If not, the Write Status Register (WRSR) command is not executed. If CS# is driven high after eighth bit of the data byte, the CMP and QE bit will be cleared to 0. As soon as CS# is driven high, the self-timed Write Status Register cycle (whose duration is tW) is initiated. While the Write Status Register cycle is in progress, the Status Register may still be read to check the value of the Write In Progress (WIP) bit. The Write In Progress (WIP) bit is 1 during the self-timed Write Status Register cycle, and is 0 when it is completed. When the cycle is completed, the Write Enable Latch (WEL) is reset.

The Write Status Register (WRSR) command allows the user to change the values of the Block Protect (BP4, BP3, BP2, BP1, BP0) bits, to define the size of the area that is to be treated as read-only, as defined in Table1. The Write Status Register (WRSR) command also allows the user to set or reset the Status Register Protect (SRP) bit in accordance with the Write Protect (WP#) signal. The Status Register Protect (SRP) bit and Write Protect (WP#) signal allow the device to be put in the Hardware Protected Mode. The Write Status Register (WRSR) command is not executed once the Hardware Protected Mode is entered.

Figure 6. Write Status Register Sequence Diagram

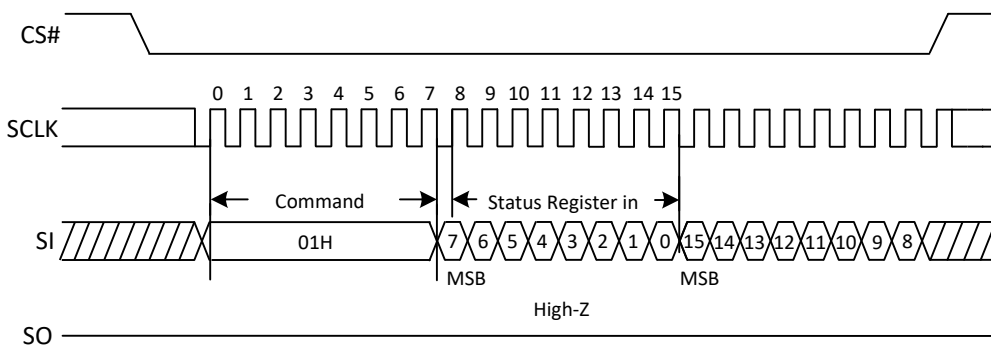
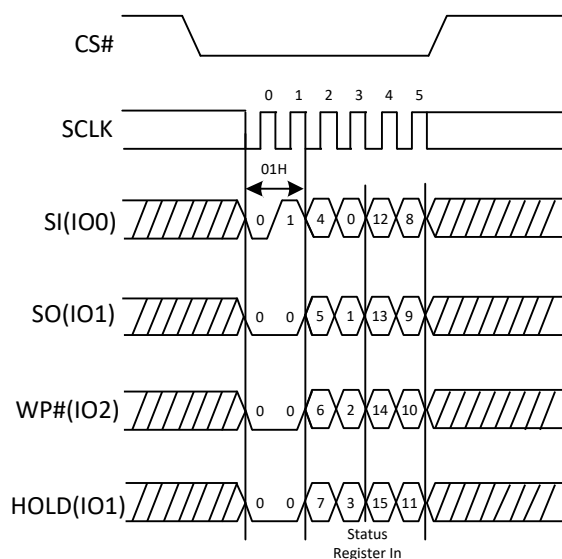

Figure 6a. Write Status Register Sequence Diagram (QPI)



6.6. Read Data Bytes (READ) (03H)

The Read Data Bytes (READ) command is followed by a 3-byte address (A23-A0), each bit being latched-in during the rising edge of SCLK. Then the memory content, at that address, is shifted out on SO, each bit being shifted out, at a Max frequency f_R , during the falling edge of SCLK. The first byte addressed can be at any location. The address is automatically incremented to the next address after each byte of data is shifted out. The whole memory can, therefore, be read with a single Read Data Bytes (READ) command. Any Read Data Bytes (READ) command, while an Erase, Program or Write cycle is in progress, is rejected without having any effects on the cycle that is in progress.

Figure 7. Read Data Bytes Sequence Diagram

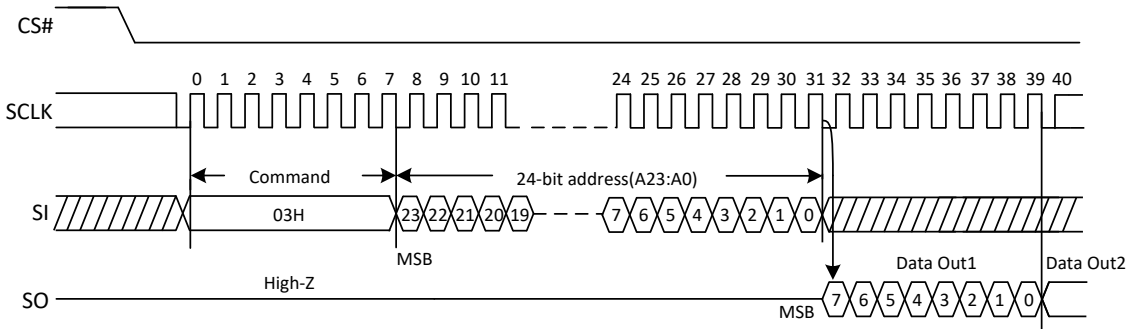

6.7. Read Data Bytes At Higher Speed (Fast Read) (0BH)

The Read Data Bytes at Higher Speed (Fast Read) command is for fast reading data out. It is followed by a 3-byte address (A23-A0) and a dummy byte, each bit being latched-in during the rising edge of SCLK. Then the memory content, at that address, is shifted out on SO, each bit being shifted out, at a Max frequency f_C , during the falling edge of SCLK. The first byte addressed can be at any location. The address is automatically incremented to the next address after each byte of data is shifted out.

Figure 8. Read Data Bytes at Higher Speed Sequence Diagram

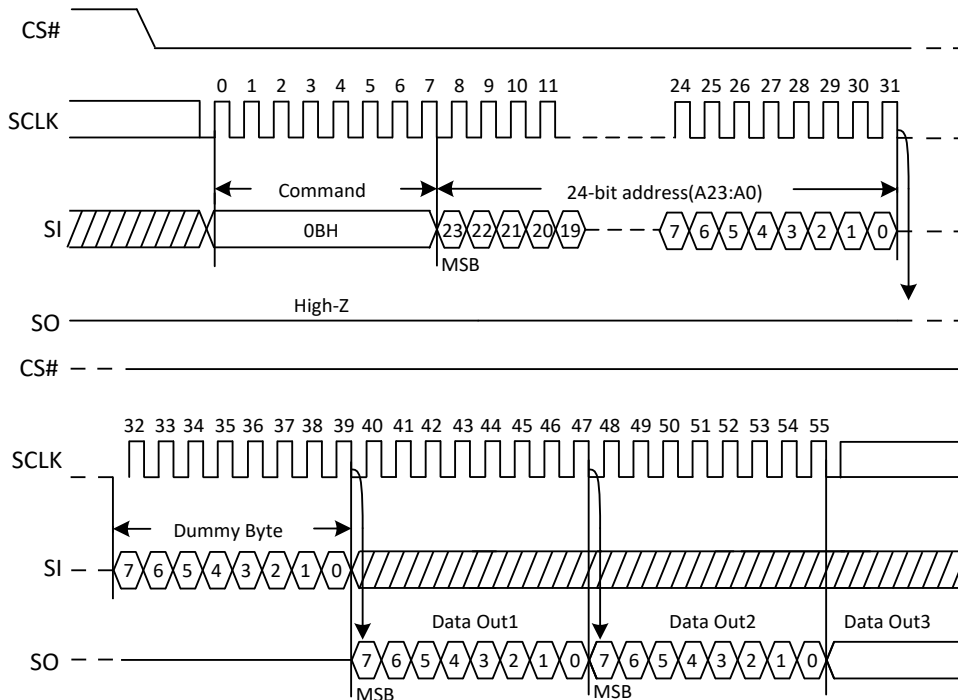

Fast Read (0BH) in QPI mode

The Fast Read command is also supported in QPI mode. In QPI mode, the number of dummy clocks is configured by the “Set Read Parameters (COH)” command to accommodate a wide range application with different needs for either maximum Fast Read frequency or minimum data access latency. Depending on the Read Parameter Bits P[5:4] setting, the number of dummy clocks can be configured as either 4/6/8. When the dummy cycle is configured to 4, addr [0] input must be 0.

Figure 8a. Read Data Bytes at Higher Speed Sequence Diagram (QPI)

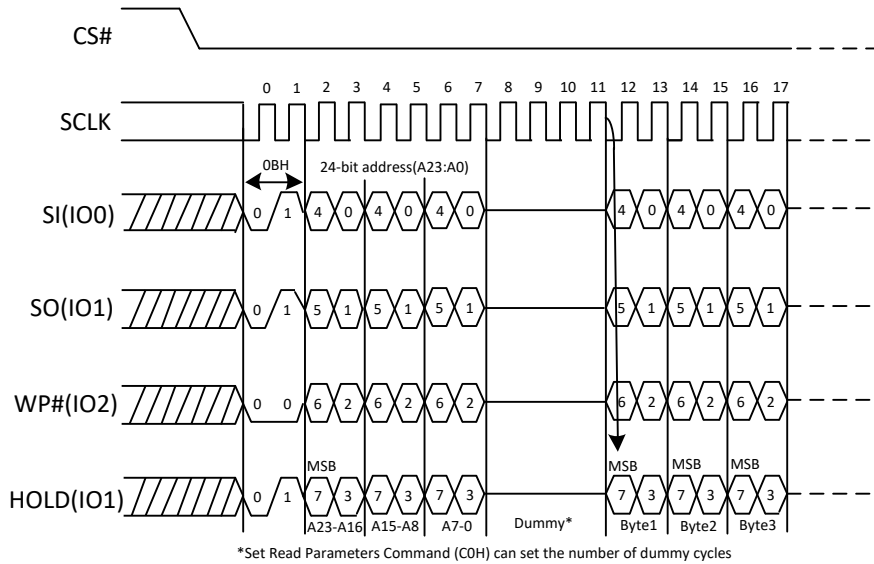

6.8. Dual Output Fast Read (3BH)

The Dual Output Fast Read command is followed by 3-byte address (A23-A0) and a dummy byte, each bit being latched in during the rising edge of SCLK, then the memory contents are shifted out 2-bit per clock cycle from SI and SO. The command sequence is shown in Figure 9. The first byte addressed can be at any location. The address is automatically incremented to the next address after each byte of data is shifted out.

Figure 9. Dual Output Fast Read Sequence Diagram

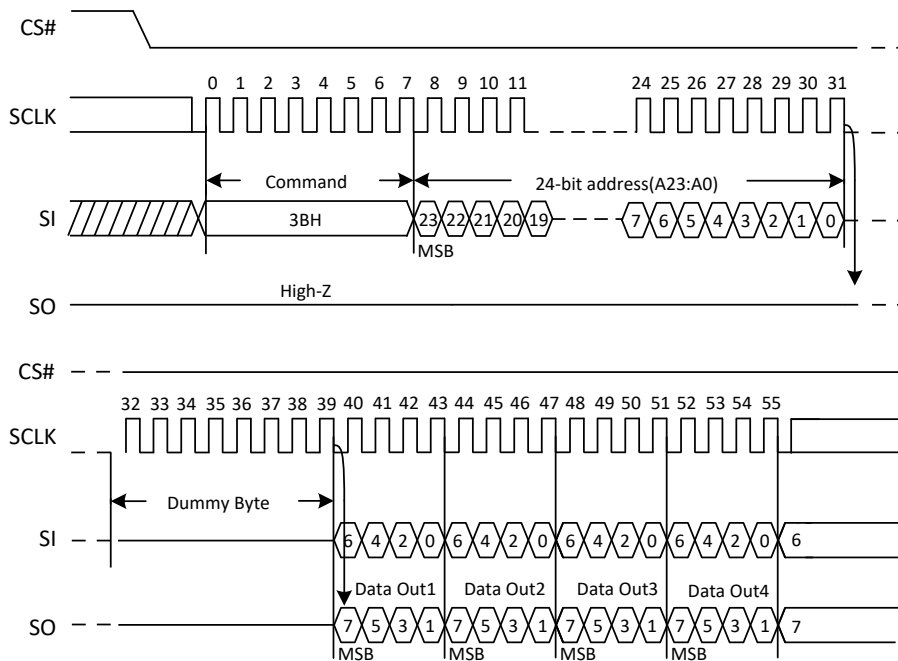



6.9. Quad Output Fast Read (6BH)

The Quad Output Fast Read command is followed by 3-byte address (A23-A0) and a dummy byte, each bit being latched in during the rising edge of SCLK, then the memory contents are shifted out 4-bit per clock cycle from IO3, IO2, IO1 and IO0. The command sequence is shown in Figure 10. The first byte addressed can be at any location. The address is automatically incremented to the next address after each byte of data is shifted out.

Figure 10. Quad Output Fast Read Sequence Diagram

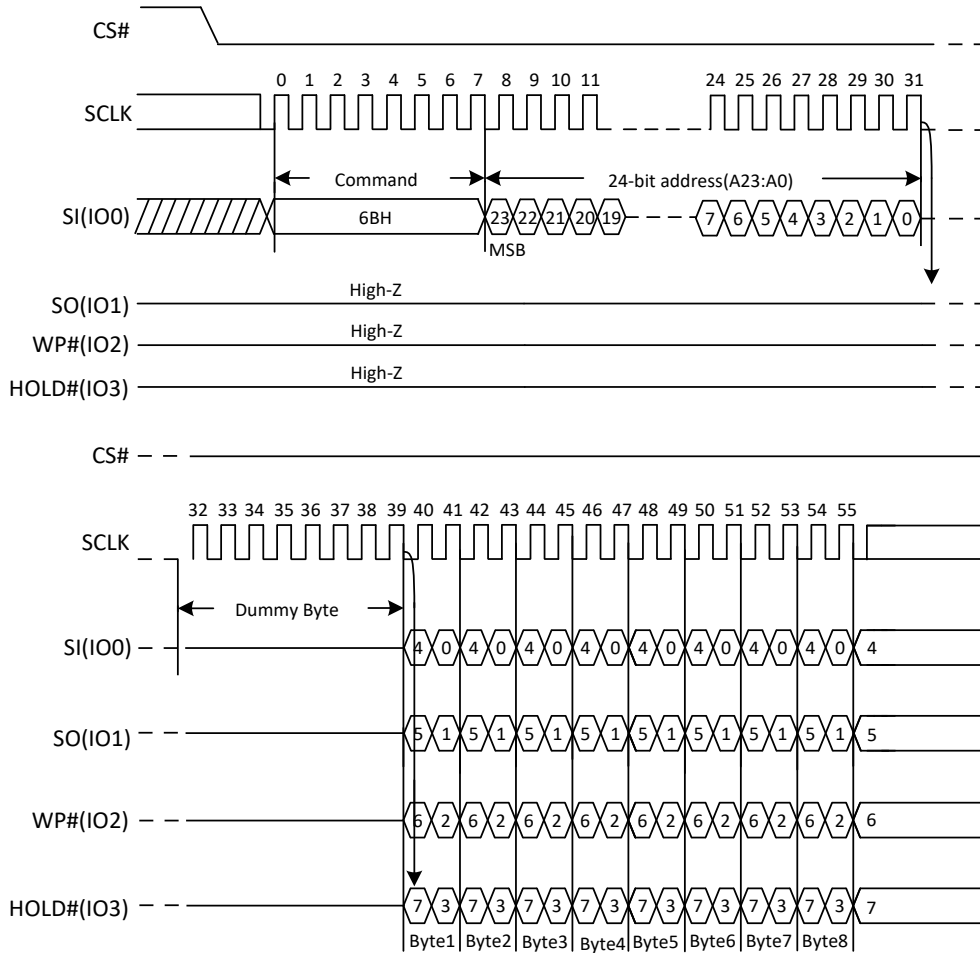

6.10. Dual I/O Fast Read (BBH)

The Dual I/O Fast Read command is similar to the Dual Output Fast Read command but with the capability to input the 3-byte address (A23-0) and a “Continuous Read Mode” byte 2-bit per clock by SI and SO, each bit being latched in during the rising edge of SCLK, then the memory contents are shifted out 2-bit per clock cycle from SI and SO. The command sequence is shown in Figure 11. The first byte addressed can be at any location. The address is automatically incremented to the next higher address after each byte of data is shifted out.

Dual I/O Fast Read with “Continuous Read Mode”

The Dual I/O Fast Read command can further reduce command overhead through setting the “Continuous Read Mode” bits (M7- 0) after the input 3-byte address (A23-A0). If the “Continuous Read Mode” bits (M5- 4) =(1, 0), then the next Dual I/O Fast Read command (after CS# is raised and then lowered) does not require the BBH command code. The command sequence is shown in figure 11a. If the “Continuous Read Mode” bits (M5- 4)

do not equal (1, 0), the next command requires the first BBH command code, thus returning to normal operation. A “Continuous Read Mode” Reset command can be used to reset (M5- 4) before issuing normal command.

Figure 11. Dual I/O Fast Read Sequence Diagram (M5-4≠(1, 0))

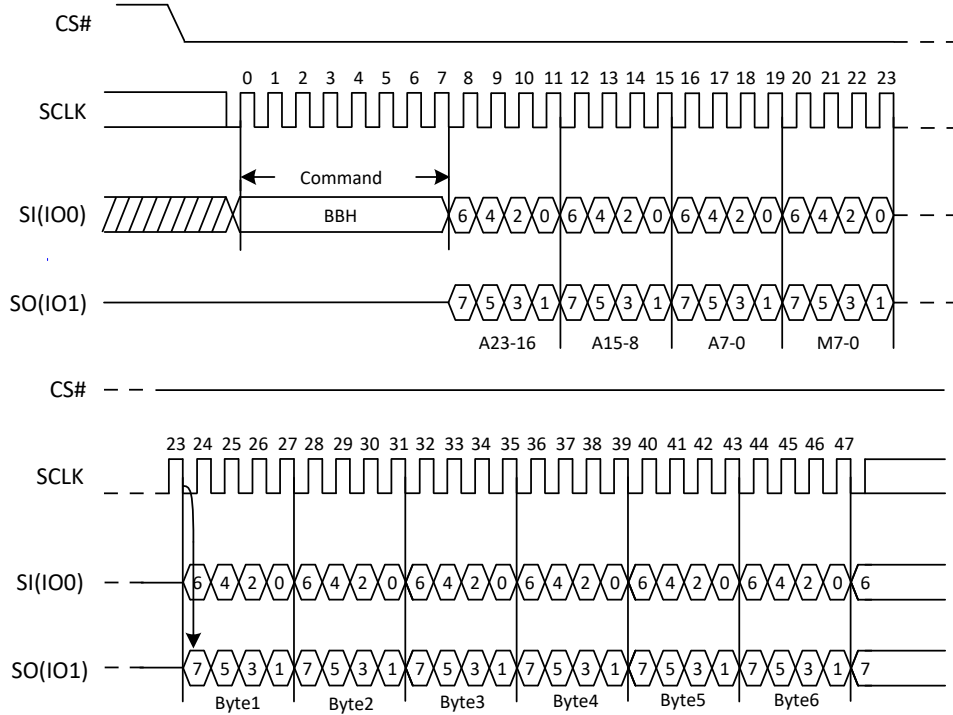
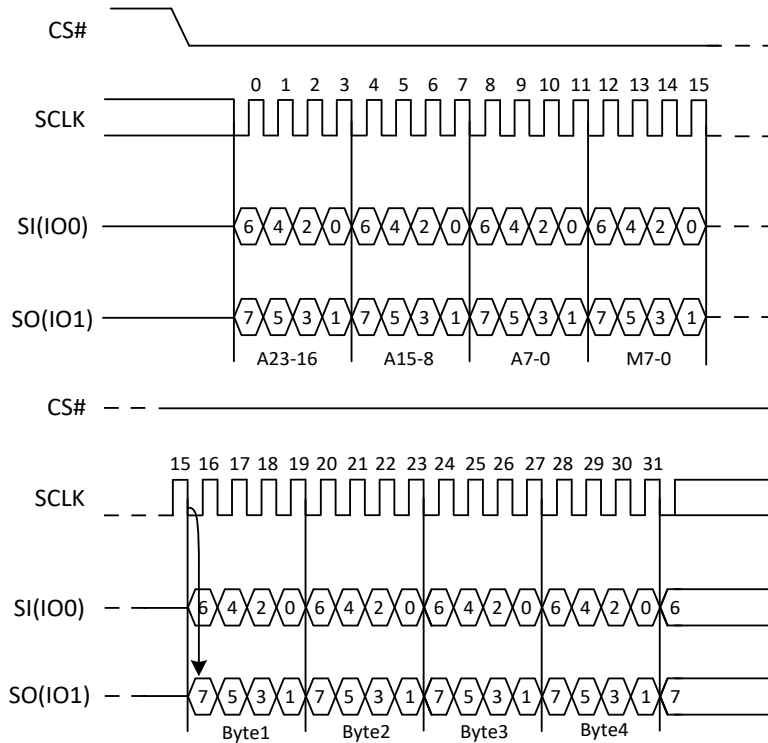

Figure 11a. Dual I/O Fast Read Sequence Diagram (M5-4= (1, 0))



6.11. Quad I/O Fast Read (EBH)

The Quad I/O Fast Read command is similar to the Dual I/O Fast Read command but with the capability to input the 3-byte address (A23-0) and a “Continuous Read Mode” byte and 4-dummy clock 4-bits per clock by IO0, IO1, IO3, IO4, each bit being latched in during the rising edge of SCLK, then the memory contents are shifted out 4-bit per clock cycle from IO0, IO1, IO2, IO3. The command sequence is shown in Figure 12. The first byte addressed can be at any location. The address is automatically incremented to the next address after each byte of data is shifted out. The Quad Enable bit (QE) of Status Register (S9) must be set to enable for the Quad I/O Fast read command.

Quad I/O Fast Read with “Continuous Read Mode”

The Quad I/O Fast Read command can further reduce command overhead through setting the “Continuous Read Mode” bits (M7-0) after the input 3-byte address (A23-A0). If the “Continuous Read Mode” bits (M5- 4)=(1, 0), then the next Quad I/O Fast Read command (after CS# is raised and then lowered) does not require the EBH command code. The command sequence is shown in Figure 12a. If the “Continuous Read Mode” (M5- 4) do not equal (1, 0), the next command requires the first EBH command code, thus returning to normal operation. A “Continuous Read Mode” Reset command can be used to reset (M5- 4) before issuing normal command.

Figure 12. Quad I/O Fast Read Sequence Diagram (M5-4≠(1, 0))

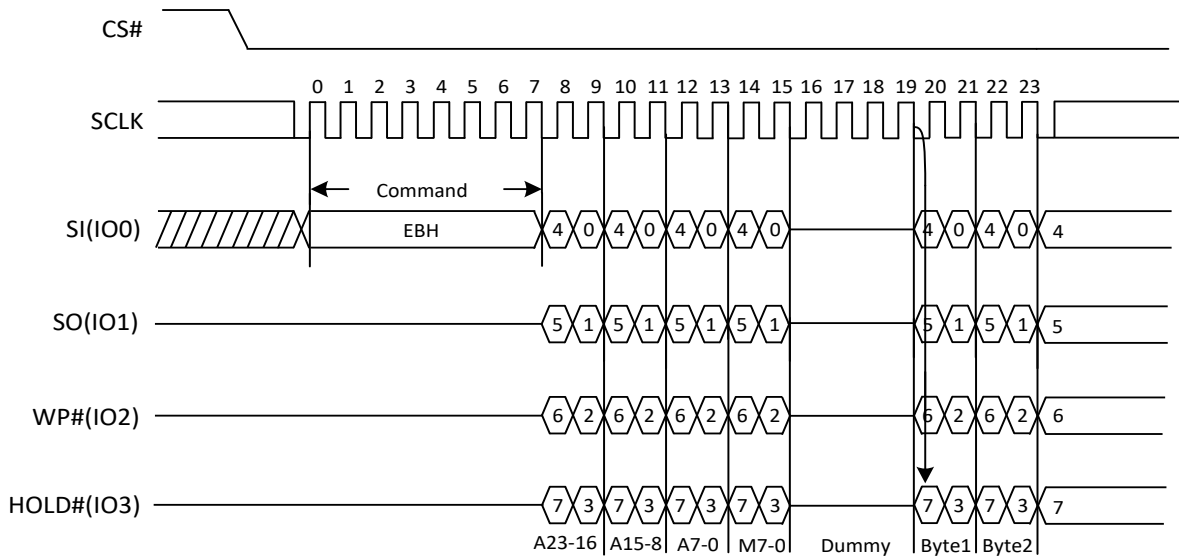
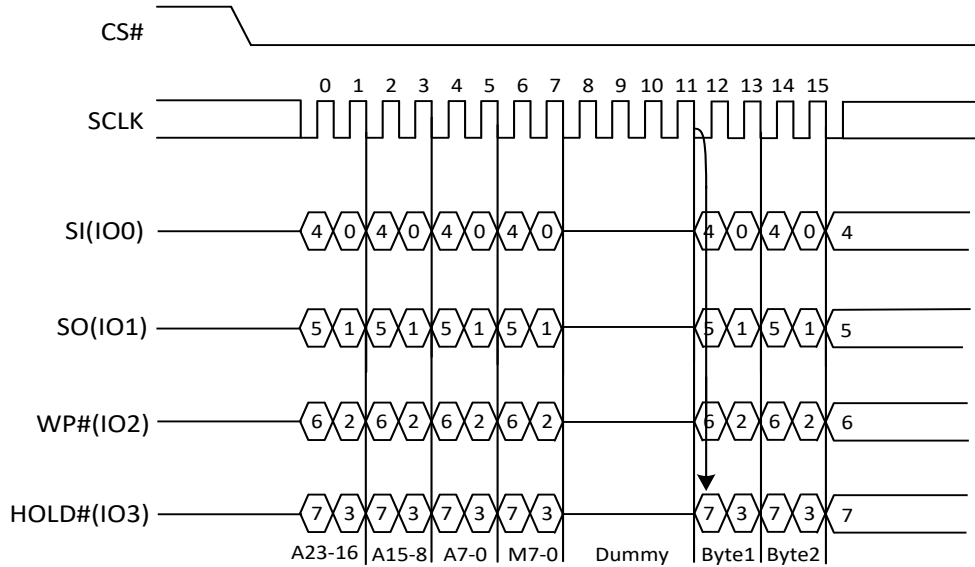

Figure 12a. Quad I/O Fast Read Sequence Diagram (M5-4= (1, 0))



Quad I/O Fast Read with “8/16/32/64-Byte Wrap Around” in Standard SPI mode

The Quad I/O Fast Read command can be used to access a specific portion within a page by issuing “Set Burst with Wrap” (77H) commands prior to EBH. The “Set Burst with Wrap” (77H) command can either enable or disable the “Wrap Around” feature for the following EBH commands. When “Wrap Around” is enabled, the data being accessed can be limited to either an 8/16/32/64-byte section of a 256-byte page. The output data starts at the initial address specified in the command, once it reaches the ending boundary of the 8/16/32/64-byte section, the output will wrap around the beginning boundary automatically until CS# is pulled high to terminate the command.

The Burst with Wrap feature allows applications that use cache to quickly fetch a critical address and then fill the cache afterwards within a fixed length (8/16/32/64-byte) of data without issuing multiple read commands. The “Set Burst with Wrap” command allows three “Wrap Bits” W6-W4 to be set. The W4 bit is used to enable or disable the “Wrap Around” operation while W6-W5 is used to specify the length of the wrap around section within a page.

Quad I/O Fast Read (EBH) in QPI mode

The Quad I/O Fast Read command is also supported in QPI mode. See Figure12b. In QPI mode, the number of dummy clocks is configured by the “Set Read Parameters (C0H)” command to accommodate a wide range application with different needs for either maximum Fast Read frequency or minimum data access latency. Depending on the Read Parameter Bits P[5:4] setting, the number of dummy clocks can be configured as either 4/6/8. When the dummy cycle is configured to 4, addr[0] input must be 0. In QPI mode, the “Continuous Read Mode” bits M7-M0 are also considered as dummy clocks. “Continuous Read Mode” feature is also available in QPI mode for Quad I/O Fast Read command. “Wrap Around” feature is not available in QPI mode for Quad I/O Fast Read command. To perform a read operation with fixed data length wrap around in QPI mode, a dedicated “Burst Read with Wrap” (0CH) command must be used.

Figure12b. Quad I/O Fast Read Sequence Diagram (M5-4= (1, 0) QPI)

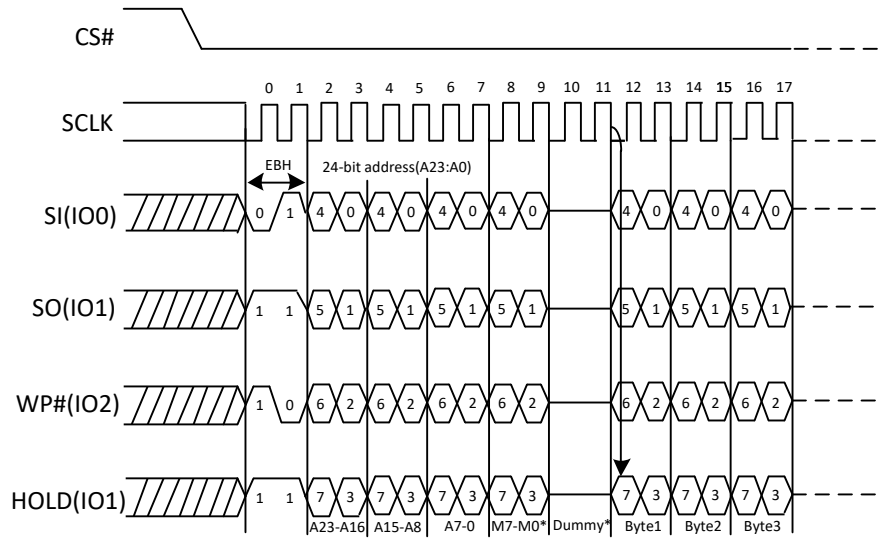

6.12. Quad I/O Word Fast Read (E7H)

The Quad I/O Word Fast Read command is similar to the Quad I/O Fast Read command except that the lowest address bit (A0) must equal 0 and only 2-dummy clock. The command sequence is shown in followed Figure 13. The first byte addressed can be at any location. The address is automatically incremented to the next higher address after each byte of data is shifted out. The Quad Enable bit (QE) of Status Register (S9) must be set to enable for the Quad I/O Word Fast read command.

Quad I/O Word Fast Read with “Continuous Read Mode”

The Quad I/O Word Fast Read command can further reduce command overhead through setting the “Continuous Read Mode” bits (M7-0) after the input 3-byte address (A23-A0). If the “Continuous Read Mode” bits (M5- 4) =(1, 0), then the next Quad I/O Word Fast Read command (after CS# is raised and then lowered) does not require the E7H command code. The command sequence is shown in followed Figure 13a. If the “Continuous Read Mode” bits (M5- 4) do not equal (1, 0), the next command requires the first E7H command code, thus returning to normal operation. A “Continuous Read Mode” Reset command can be used to reset (M7-0) before issuing normal command.

Figure 13. Quad I/O Word Fast Read Sequence Diagram (M5-4≠(1, 0))

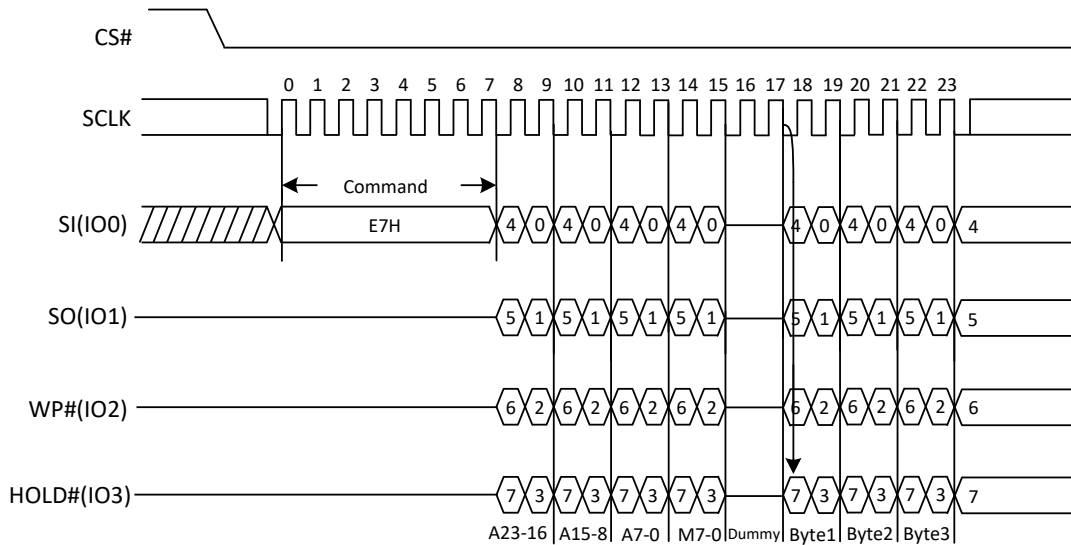
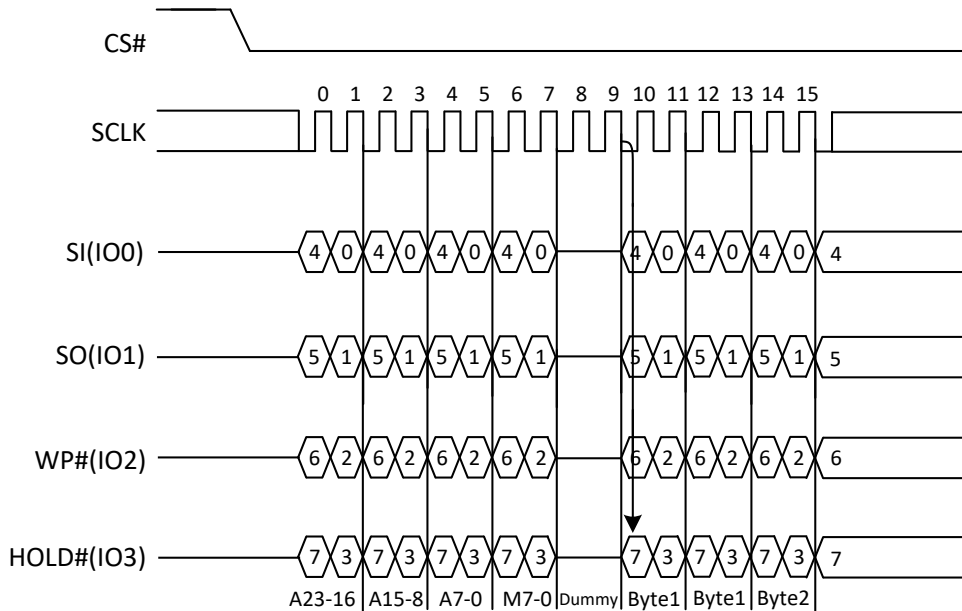

Figure13a. Quad I/O Word Fast Read Sequence Diagram (M5-4= (1, 0))



Quad I/O Word Fast Read with “8/16/32/64-Byte Wrap Around” in Standard SPI mode

The Quad I/O Word Fast Read command can be used to access a specific portion within a page by issuing “Set Burst with Wrap” (77H) commands prior to E7H. The “Set Burst with Wrap” (77H) command can either enable or disable the “Wrap Around” feature for the following E7H commands. When “Wrap Around” is enabled, the data being accessed can be limited to either an 8/16/32/64-byte section of a 256-byte page. The output data starts at the initial address specified in the command, once it reaches the ending boundary of the 8/16/32/64-byte section, the output will wrap around the beginning boundary automatically until CS# is pulled high to terminate the command. The Burst with Wrap feature allows applications that use cache to quickly fetch a critical address and then fill the cache afterwards within a fixed length (8/16/32/64-byte) of data without issuing multiple read commands. The “Set Burst with Wrap” command allows three “Wrap Bits” W6-W4 to be set. The W4 bit is used to enable or disable the “Wrap Around” operation while W6-W5 is used to specify the length of the wrap around section within a page.

6.13. Set Burst with Wrap (77H)

The Set Burst with Wrap command is used in conjunction with “Quad I/O Fast Read” and “Quad I/O Word Fast Read” command to access a fixed length of 8/16/32/64-byte section within a 256-byte page, in standard SPI mode. The Set Burst with Wrap command sequence: CS# goes low → Send Set Burst with Wrap command → Send 24 dummy bits → Send 8 bits “Wrap bits” → CS# goes high

W6,W5	W4=0		W4=1(default)	
	Wrap Around	Wrap Length	Wrap Around	Wrap Length
0,0	Yes	8-byte	No	N/A
0,1	Yes	16-byte	No	N/A
1,0	Yes	32-byte	No	N/A
1,1	Yes	64-byte	No	N/A

If the W6-W4 bits are set by the Set Burst with Wrap command, all the following “Quad I/O Fast Read” and “Quad I/O Word Fast Read” command will use the W6-W4 setting to access the 8/16/32/64-byte section within any page. To exit the “Wrap Around” function and return to normal read operation, another Set Burst with Wrap command should be issued to set W4=1. In QPI mode, the “Burst Read with Wrap (0CH)” command should be used to perform the Read Operation with “Wrap Around” feature. The Wrap Length set by W5-W6 in Standard SPI mode is still valid in QPI mode and can also be re-configured by “Set Read Parameters (COH) command.

Figure 14. Set Burst with Wrap Sequence Diagram

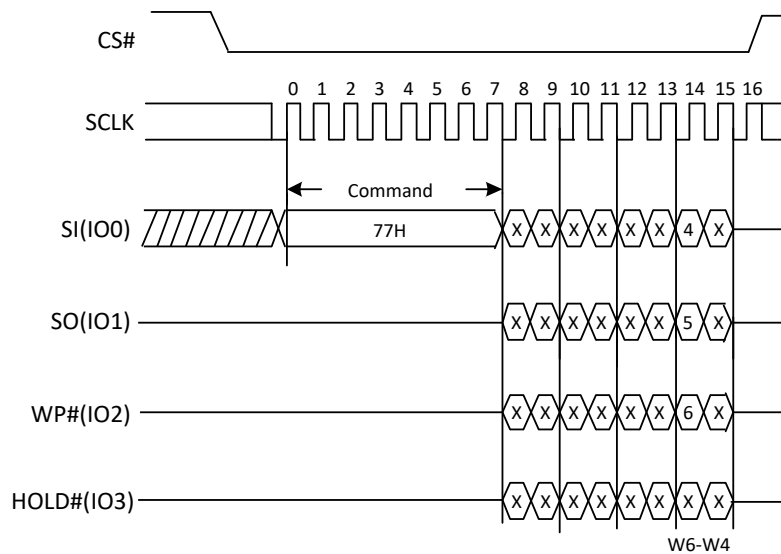

6.14. Page Program (PP) (02H)

The Page Program (PP) command is for programming the memory. A Write Enable (WREN) command must previously have been executed to set the Write Enable Latch (WEL) bit before sending the Page Program command.

The Page Program (PP) command is entered by driving CS# Low, followed by the command code, three address bytes and at least one data byte on SI. If the 8 least significant address bits (A7-A0) are not all zero, all transmitted data that goes beyond the end of the current page are programmed from the start address of the same page (from the address whose 8 least significant bits (A7-A0) are all zero). CS# must be driven low for the entire duration of the sequence. The Page Program command sequence: CS# goes low → sending Page Program command → 3-byte address on SI → at least 1 byte data on SI → CS# goes high. The command sequence is shown in Figure 15. If more than 256 bytes are sent to the device, previously latched data are discarded and the last 256 data bytes are guaranteed to be programmed correctly within the same page. If less than 256 data bytes are sent to device, they are correctly programmed at the requested addresses without having any effects on the other bytes of the same page. CS# must be driven high after the eighth bit of the last data byte has been latched in; otherwise the Page Program (PP) command is not executed.

As soon as CS# is driven high, the self-timed Page Program cycle (whose duration is t_{PP}) is initiated. While the Page Program cycle is in progress, the Status Register may be read to check the value of the Write In Progress (WIP) bit. The Write In Progress (WIP) bit is 1 during the self-timed Page Program cycle, and is 0 when it is completed. At some unspecified time before the cycle is completed, the Write Enable Latch (WEL) bit is reset.

A Page Program (PP) command applied to a page which is protected by the Block Protect (BP4, BP3, BP2, BP1, BP0) is not executed.

Figure 15. Page Program Sequence Diagram

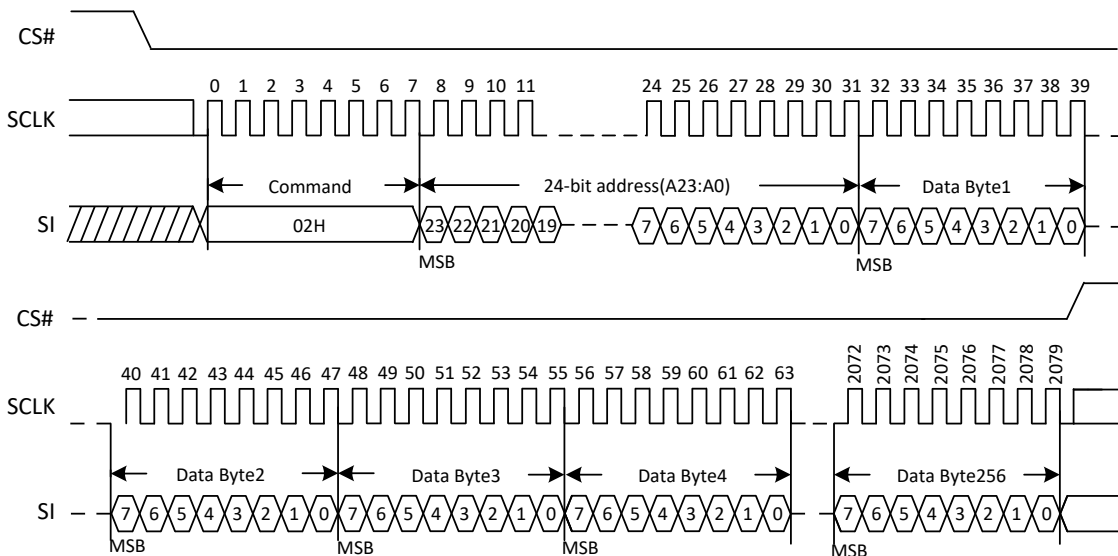
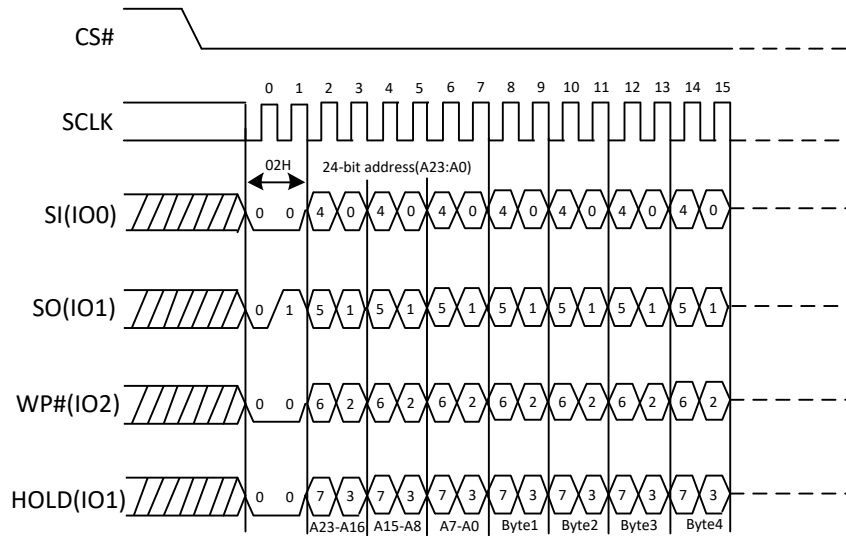

Figure15a. Page Program Sequence Diagram (QPI)



6.15. Quad Page Program (QPP) (32H)

The Quad Page Program command is for programming the memory using four pins: IO0, IO1, IO2, and IO3. To use Quad Page Program the Quad enable in status register Bit9 must be set (QE=1). A Write Enable (WREN) command must previously have been executed to set the Write Enable Latch (WEL) bit before sending the Page Program command. The Quad Page Program command is entered by driving CS# Low, followed by the command code (32H), three address bytes and at least one data byte on IO pins.

The command sequence is shown in Figure 16. If more than 256 bytes are sent to the device, previously latched data are discarded and the last 256 data bytes are guaranteed to be programmed correctly within the same page. If less than 256 data bytes are sent to device, they are correctly programmed at the requested addresses without having any effects on the other bytes of the same page. CS# must be driven high after the eighth bit of the last data byte has been latched in; otherwise the Quad Page Program command is not executed.

As soon as CS# is driven high, the self-timed Quad Page Program cycle (whose duration is tPP) is initiated. While the Quad Page Program cycle is in progress, the Status Register may be read to check the value of the Write In Progress (WIP) bit. The Write In Progress (WIP) bit is 1 during the self-timed Quad Page Program cycle, and is 0 when it is completed. At some unspecified time before the cycle is completed, the Write Enable Latch (WEL) bit is reset.

A Quad Page Program command applied to a page which is protected by the Block Protect (BP4, BP3, BP2, BP1, BP0) will not be executed.

Figure 16. Quad Page Program Sequence Diagram

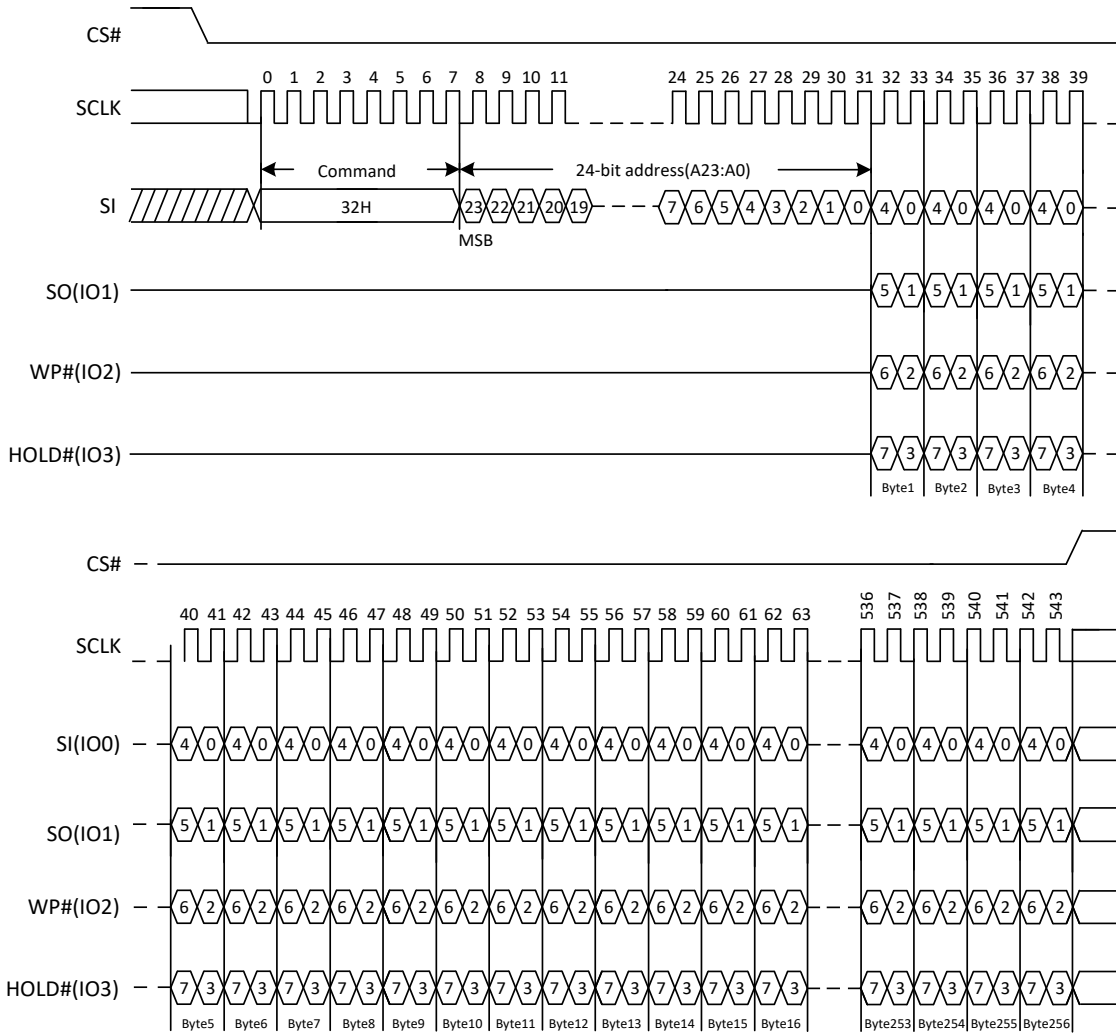

6.16. Sector Erase (SE) (20H)

The Sector Erase (SE) command is for erasing the all data of the chosen sector. A Write Enable (WREN) command must previously have been executed to set the Write Enable Latch (WEL) bit. The Sector Erase (SE) command is entered by driving CS# low, followed by the command code, and 3-address byte on SI. Any address inside the sector is a valid address for the Sector Erase (SE) command. CS# must be driven low for the entire duration of the sequence.

The Sector Erase command sequence: CS# goes low → sending Sector Erase command → 3-byte address on SI → CS# goes high. The command sequence is shown in Figure 17. CS# must be driven high after the eighth bit of the last address byte has been latched in; otherwise the Sector Erase (SE) command is not executed. As soon as CS# is driven high, the self-timed Sector Erase cycle (whose duration is tSE) is initiated. While the Sector Erase cycle is in progress, the Status Register may be read to check the value of the Write In Progress (WIP) bit. The Write In Progress (WIP) bit is 1 during the self-timed Sector Erase cycle, and is 0 when it is completed. At some unspecified time before the cycle is completed, the Write Enable Latch (WEL) bit is reset. A Sector Erase (SE) command applied to a sector which is protected by the Block Protect (BP4, BP3, BP2, BP1, BPO) bit (see Table 1.0 & 1.1) will not be executed.

Note: Power disruption during erase operation will cause incomplete erase and data corruption, thus recommend to perform a re-erase once power resume.

Figure 17. Sector Erase Sequence Diagram

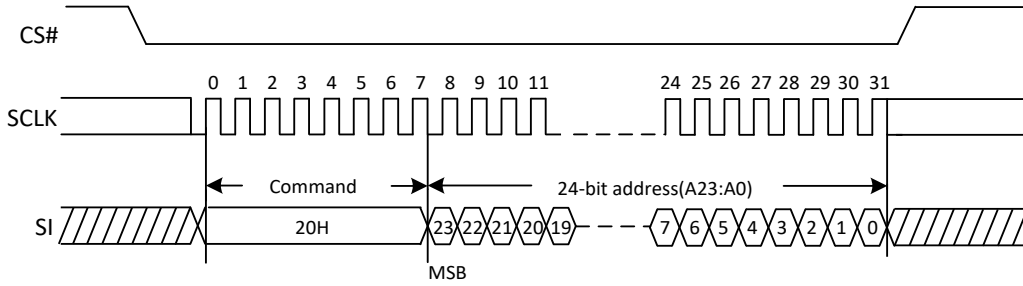
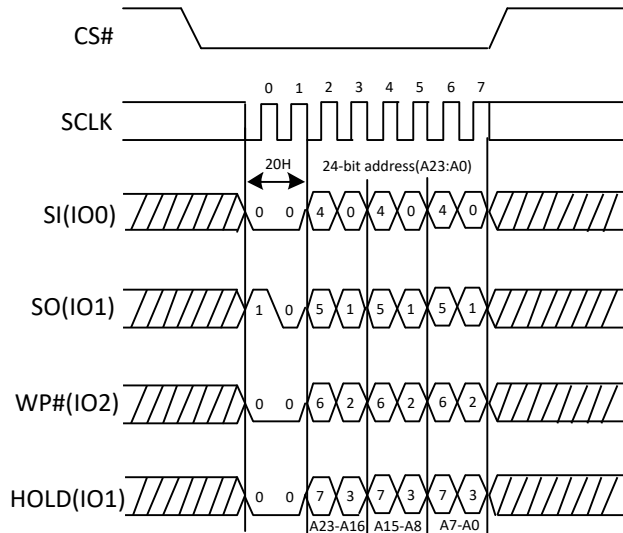

Figure17a. Sector Erase Sequence Diagram (QPI)



6.17. 32KB Block Erase (BE) (52H)

The 32KB Block Erase (BE) command is for erasing the all data of the chosen block. A Write Enable (WREN) command must previously have been executed to set the Write Enable Latch (WEL) bit. The 32KB Block Erase (BE) command is entered by driving CS# low, followed by the command code, and three address bytes on SI. Any address inside the block is a valid address for the 32KB Block Erase (BE) command. CS# must be driven low for the entire duration of the sequence.

The 32KB Block Erase command sequence: CS# goes low → sending 32KB Block Erase command → 3-byte address on SI → CS# goes high. The command sequence is shown in Figure18. CS# must be driven high after the eighth bit of the last address byte has been latched in; otherwise the 32KB Block Erase (BE) command is not executed. As soon as CS# is driven high, the self-timed Block Erase cycle (whose duration is tBE) is initiated. While the Block Erase cycle is in progress, the Status Register may be read to check the value of the Write In Progress (WIP) bit. The Write In Progress (WIP) bit is 1 during the self-timed Block Erase cycle, and is 0 when it is completed. At some unspecified time before the cycle is completed, the Write Enable Latch (WEL) bit is reset. A 32KB Block Erase (BE) command applied to a block which is protected by the Block Protect (BP4, BP3, BP2, BP1, BP0) bits (see Table1.0 & 1.1) will not be executed.

Note: Power disruption during erase operation will cause incomplete erase and data corruption, thus recommend to perform a re-erase once power resume.

Figure 18. 32KB Block Erase Sequence Diagram

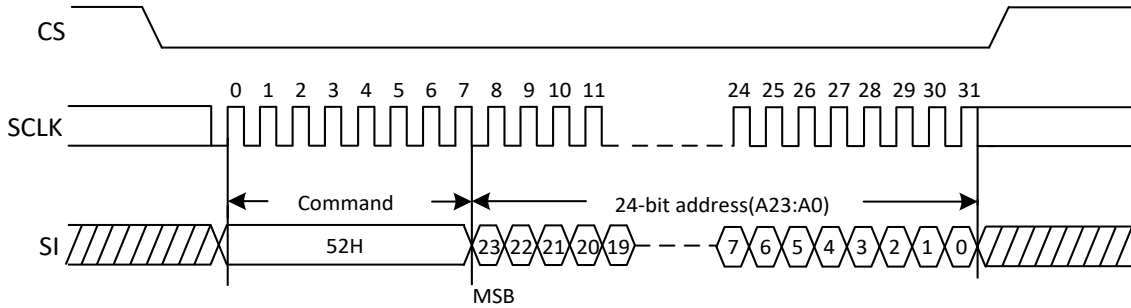
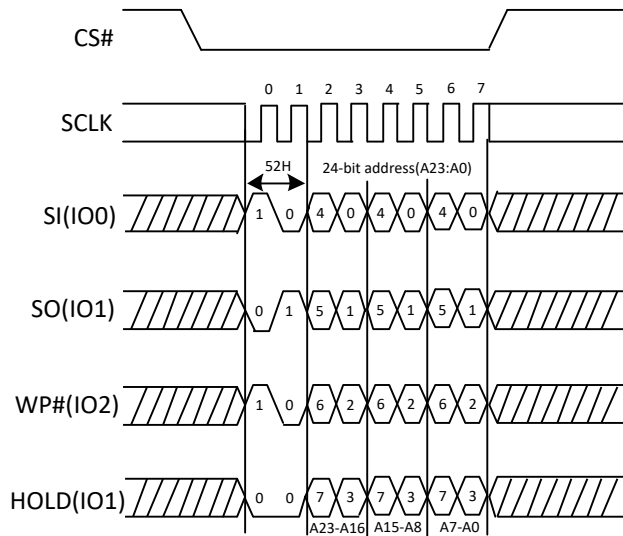

Figure 18a. 32KB Block Erase Sequence Diagram (QPI)



6.18. 64KB Block Erase (BE) (D8H)

The 64KB Block Erase (BE) command is for erasing the all data of the chosen block. A Write Enable (WREN) command must previously have been executed to set the Write Enable Latch (WEL) bit. The 64KB Block Erase (BE) command is entered by driving CS# low, followed by the command code, and three address bytes on SI. Any address inside the block is a valid address for the 64KB Block Erase (BE) command. CS# must be driven low for the entire duration of the sequence.

The 64KB Block Erase command sequence: CS# goes low → sending 64KB Block Erase command → 3-byte address on SI → CS# goes high. The command sequence is shown in Figure 19. CS# must be driven high after the eighth bit of the last address byte has been latched in; otherwise the 64KB Block Erase (BE) command is not executed. As soon as CS# is driven high, the self-timed Block Erase cycle (whose duration is tBE) is initiated. While the Block Erase cycle is in progress, the Status Register may be read to check the value of the Write In Progress (WIP) bit. The Write In Progress (WIP) bit is 1 during the self-timed Block Erase cycle, and is 0 when it is completed. At some unspecified time before the cycle is completed, the Write Enable Latch (WEL) bit is reset. A 64KB Block Erase (BE) command applied to a block which is protected by the Block Protect (BP4, BP3, BP2, BP1, BP0) bits (see Table 1.0 & 1.1) will not be executed.

Note: Power disruption during erase operation will cause incomplete erase and data corruption, thus recommend to perform a re-erase once power resume.

Figure 19. 64KB Block Erase Sequence Diagram

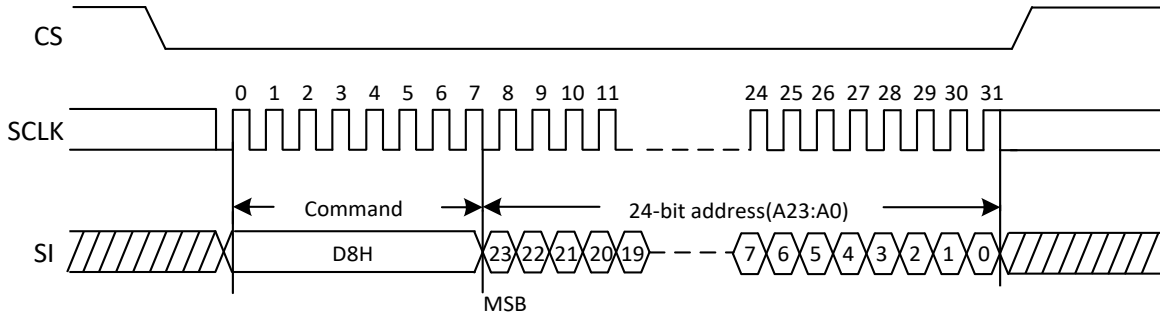
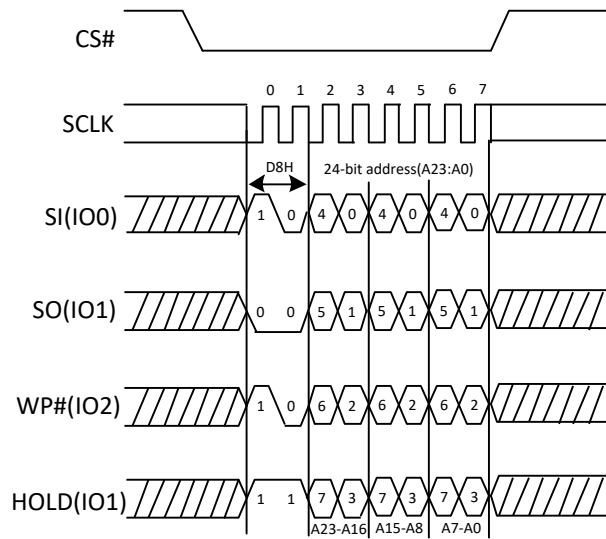

Figure19a. 64KB Block Erase Sequence Diagram (QPI)



6.19. Chip Erase (CE) (60/C7H)

The Chip Erase (CE) command is for erasing the all data of the chip. A Write Enable (WREN) command must previously have been executed to set the Write Enable Latch (WEL) bit .The Chip Erase (CE) command is entered by driving CS# Low, followed by the command code on Serial Data Input (SI). CS# must be driven Low for the entire duration of the sequence.

The Chip Erase command sequence: CS# goes low → sending Chip Erase command → CS# goes high. The command sequence is shown in Figure 20. CS# must be driven high after the eighth bit of the command code has been latch in, otherwise the Chip Erase command is not executed. As soon as CS# is driven high, the self-timed Chip Erase cycle (whose duration is t_{CE}) is initiated. While the Chip Erase cycle is in progress, the Status Register may be read to check the value of the Write In Progress (WIP) bit. The Write In Progress (WIP) bit is 1 during the self-timed Chip Erase cycle, and is 0 when it is completed. At some unspecified time before the cycle is completed, the Write Enable Latch (WEL) bit is reset. The Chip Erase (CE) command is ignored if one or more sectors are protected.

Note: Power disruption during erase operation will cause incomplete erase and data corruption, thus recommend to perform a re-erase once power resume.

Figure 20. Chip Erase Sequence Diagram

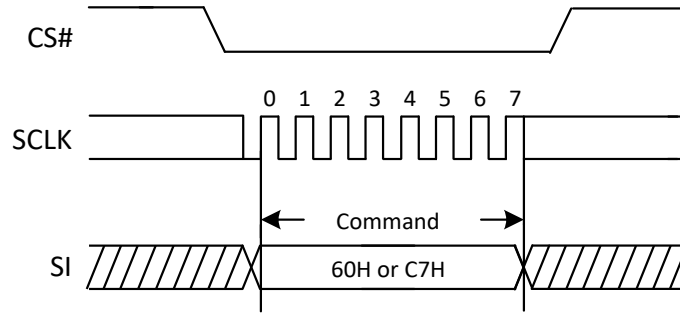
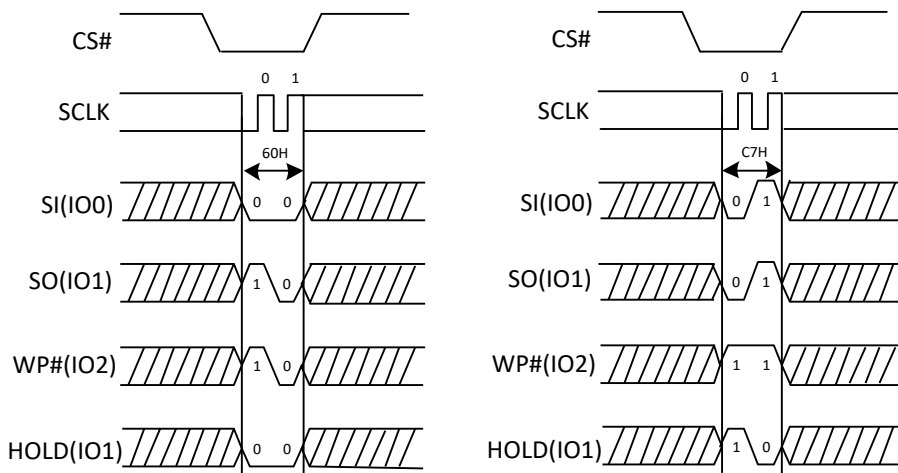

Figure 20a. Chip Erase Sequence Diagram (QPI)



6.20. Deep Power-Down (DP) (B9H)

Executing the Deep Power-Down (DP) command is the only way to put the device in the lowest consumption mode (the Deep Power-Down Mode). It can also be used as an extra software protection mechanism, while the device is not in active use, since in this mode, the device ignores all Write, Program and Erase commands. Driving CS# high deselected the device, and puts the device in the Standby Mode (if there is no internal cycle currently in progress). But this mode is not the Deep Power-Down Mode. The Deep Power-Down Mode can only be entered by executing the Deep Power-Down (DP) command. Once the device has entered the Deep Power-Down Mode, all commands are ignored except the Release from Deep Power-Down and Read Device ID (RDI) command. This releases the device from this mode. The Release from Deep Power-Down and Read Device ID (RDI) command also allows the Device ID of the device to be output on SO.

The Deep Power-Down Mode automatically stops at Power-Down, and the device always Power-Up in the Standby Mode. The Deep Power-Down (DP) command is entered by driving CS# low, followed by the command code on SI. CS# must be driven low for the entire duration of the sequence.

The Deep Power-Down command sequence: CS# goes low → sending Deep Power-Down command → CS# goes high. The command sequence is shown in Figure 21. CS# must be driven high after the eighth bit of the command code has been latched in; otherwise the Deep Power-Down (DP) command is not executed. As soon as CS# is driven high, it requires a delay of tDP before the supply current is reduced to ICC2 and the Deep Power-Down Mode is entered. Any Deep Power-Down (DP) command, while an Erase, Program or Write cycle is in progress, is rejected without having any effects on the cycle that is in progress.

Figure 21. Deep Power-Down Sequence Diagram

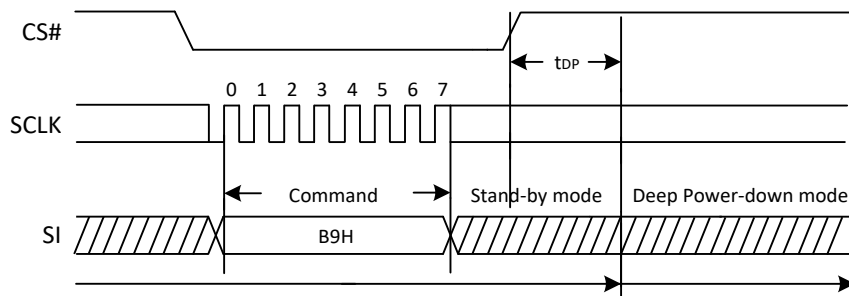
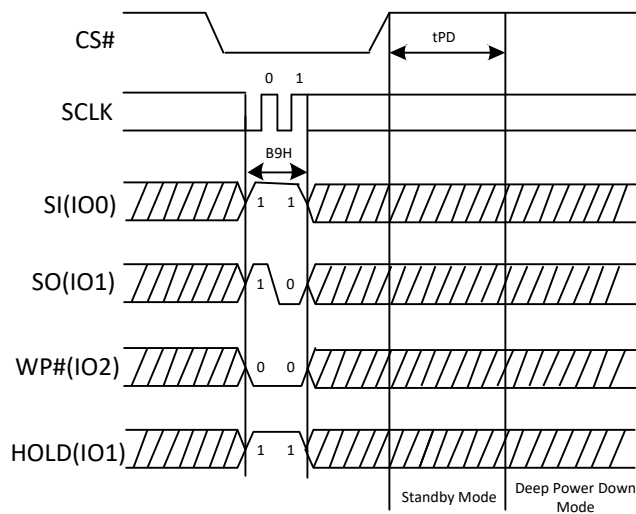

Figure 21a. Deep Power-Down Sequence Diagram (QPI)



6.21. Release from Deep Power-Down and Read Device ID (RDI) (ABH)

The Release from Power-Down and Read/Device ID command is a multi-purpose command. It can be used to release the device from the Power-Down state or obtain the devices electronic identification (ID) number.

To release the device from the Power-Down state, the command is issued by driving the CS# pin low, shifting the instruction code “ABH” and driving CS# high as shown in Figure22. Release from Power-Down will take the time duration of tRES1 (See AC Characteristics) before the device will resume normal operation and other command are accepted. The CS# pin must remain high during the tRES1 time duration.

When used only to obtain the Device ID while not in the Power-Down state, the command is initiated by driving the CS# pin low and shifting the instruction code “ABH” followed by 3-dummy byte. The Device ID bits are then shifted out on the falling edge of SCLK with most significant bit (MSB) first as shown in Figure22b. The Device ID value for the device is listed in Manufacturer and Device Identification table. The Device ID can be read continuously. The command is completed by driving CS# high.

When used to release the device from the Power-Down state and obtain the Device ID, the command is the same as previously described, and shown in Figure 22b, except that after CS# is driven high it must remain high for a time duration of tRES2 (See AC Characteristics). After this time duration the device will resume normal operation and other command will be accepted. If the Release from Power-Down/Device ID command is issued while an Erase, Program or Write cycle is in process (when WIP equal 1) the command is ignored and will not affects on the current cycle.

Figure 22. Release Power-Down Sequence Diagram

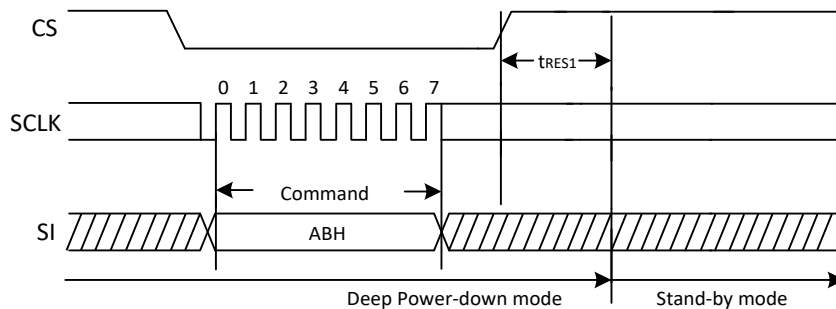

Figure 22a. Release Power-Down Sequence Diagram (QPI)

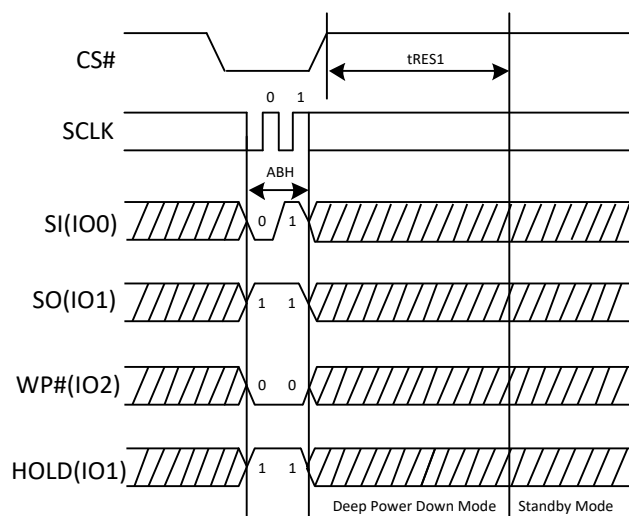

Figure 22b. Release Power-Down/Read Device ID Sequence Diagram

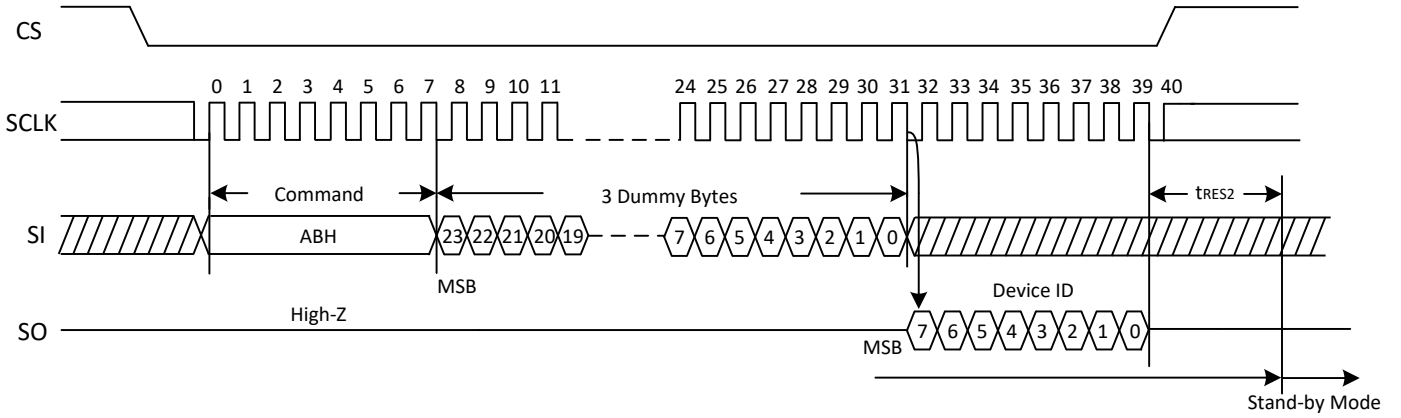
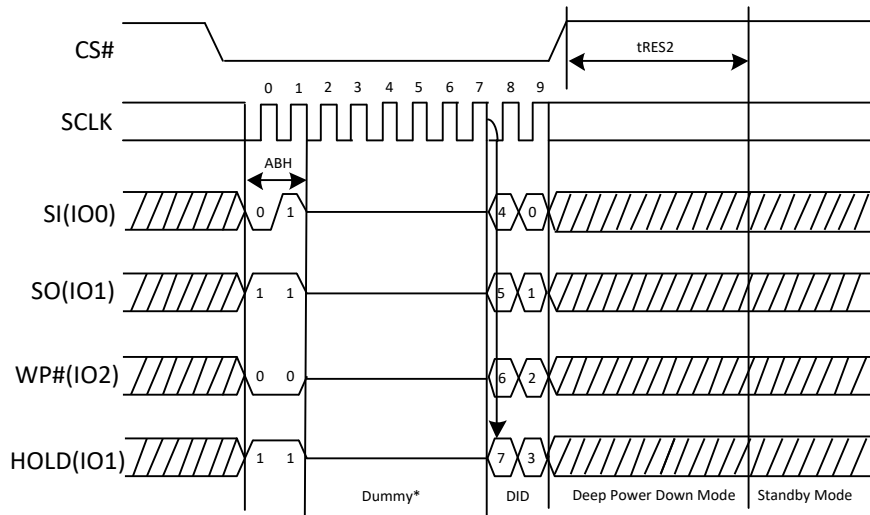

Figure 22c. Release Power-Down/Read Device ID Sequence Diagram (QPI)



6.22. Read Manufacturer ID/ Device ID (REMS) (90H)

The Read Manufacturer/Device ID command is an alternative to the Release from Power-Down / Device ID command that provides both the JEDEC assigned Manufacturer ID and the specific Device ID.

The command is initiated by driving the CS# pin low and shifting the command code “90H” followed by a 24-bit address (A23-A0) of 000000H. After which, the Manufacturer ID and the Device ID are shifted out on the falling edge of SCLK with most significant bit (MSB) first is shown in Figure 23. If the 24-bit address is initially set to 000001H, the Device ID will be read first. In QPI mode the dummy cycles can be configured by COH command. When the dummy cycle is configured to 4, addr[0] input must be 0.

Figure 23. Read Manufacturer ID/ Device ID Sequence Diagram

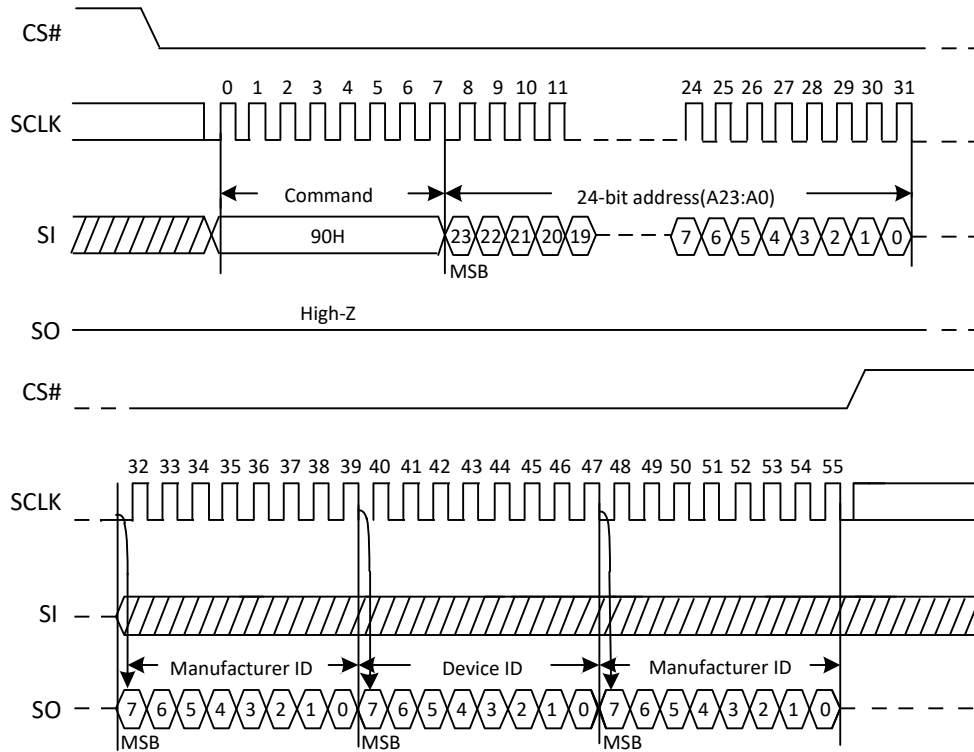
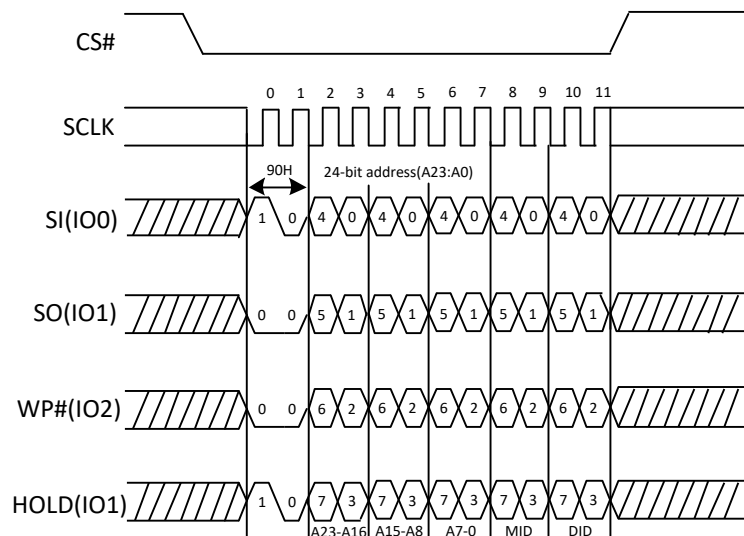

Figure 23a. Read Manufacturer ID/ Device ID Sequence Diagram (QPI)



6.23. Read Manufacture ID/ Device ID Dual I/O (92H)

The Read Manufacturer/Device ID Dual I/O command is an alternative to the Release from Power-Down / Device ID command that provides both the JEDEC assigned Manufacturer ID and the specific Device ID by dual I/O.

The command is initiated by driving the CS# pin low and shifting the command code “92H” followed by a 24-bit address (A23-A0) of 000000H. After which, the Manufacturer ID and the Device ID are shifted out on the falling edge of SCLK with most significant bit (MSB) first as shown in Figure 24. If the 24-bit address is initially set to 000001H, the Device ID will be read first.

Figure 24. Read Manufacture ID/ Device ID Dual I/O Sequence Diagram

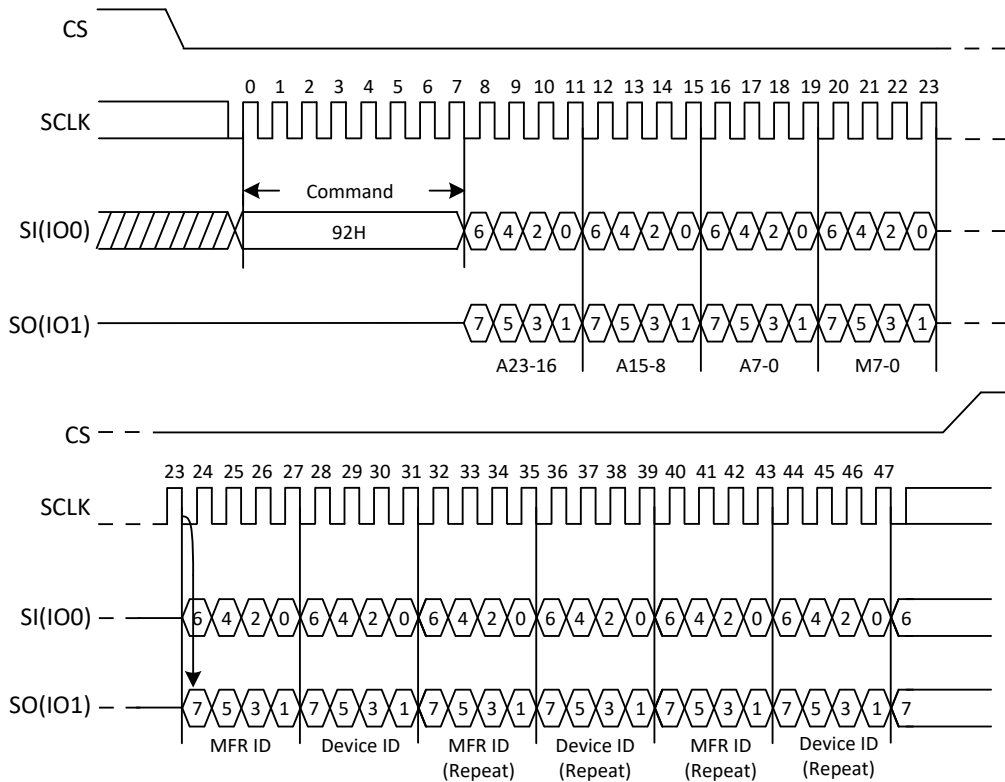

6.24. Read Manufacturer ID/ Device ID Quad I/O (94H)

The Read Manufacturer/Device ID Quad I/O command is an alternative to the Release from Power-Down / Device ID command that provides both the JEDEC assigned Manufacturer ID and the specific Device ID by quad I/O. The command is initiated by driving the CS# pin low and shifting the command code “94H” followed by a 24-bit address (A23-A0) of 000000H. After which, the Manufacturer ID and the Device ID are shifted out on the falling edge of SCLK with most significant bit (MSB) first is shown in Figure 25. If the 24-bit address is initially set to 000001H, the Device ID will be read first.

Figure 25. Read Manufacturer ID/ Device ID Quad I/O Sequence Diagram

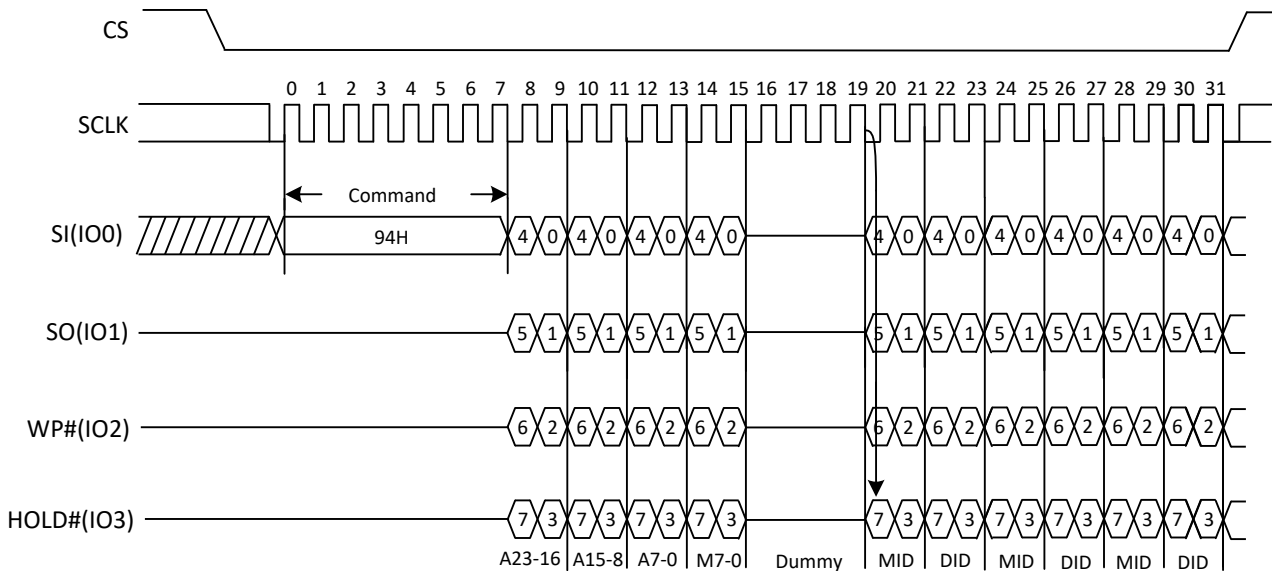

6.25. Read Identification (RDID) (9FH)

The Read Identification (RDID) command allows the 8-bit manufacturer identification to be read, followed by two bytes of device identification. The device identification indicates the memory type in the first byte, and the memory capacity of the device in the second byte. Any Read Identification (RDID) command while an Erase or Program cycle is in progress, is not decoded, and has no effect on the cycle that is in progress. The Read Identification (RDID) command should not be issued while the device is in Deep Power-Down Mode.

The device is first selected by driving CS# to low. Then, the 8-bit command code for the command is shifted in. This is followed by the 24-bit device identification, stored in the memory, being shifted out on Serial Data Output, each bit being shifted out during the falling edge of Serial Clock. The command sequence is shown in Figure 26. The Read Identification (RDID) command is terminated by driving CS# to high at any time during data output. When CS# is driven high, the device is put in the Standby Mode. Once in the Standby Mode, the device waits to be selected, so that it can receive, decode and execute commands.

Figure 26. Read Identification ID Sequence Diagram

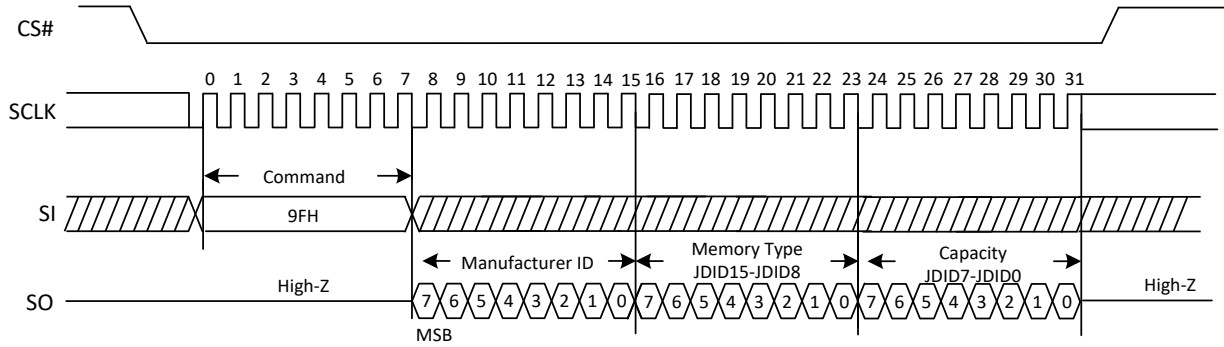

6.26. Erase Security Registers (44H)

The XT25W32B provides four 256-byte Security Registers which only erased all at once but able to program individually. These registers may be used by the system manufacturers to store security and other important information separately from the main memory array.

The Erase Security Registers command is similar to Sector/Block Erase command. A Write Enable (WREN) command must previously have been executed to set the Write Enable Latch (WEL) bit.

The Erase Security Registers command sequence: CS# goes low → sending Erase Security Registers Command → CS# goes high. The command sequence is shown in Figure 29. CS# must be driven high after the eighth bit of the command code has been latched in, otherwise the Erase Security Registers command is not executed. As soon as CS# is driven high, the self-timed Erase Security Registers cycle (whose duration is tSE) is initiated. While the Erase Security Registers cycle is in progress, the Status Register may be read to check the value of the Write In Progress (WIP) bit. The Write In Progress (WIP) bit is 1 during the self-timed Erase Security Registers cycle, and is 0 when it is completed. At some unspecified time before the cycle is completed, the Write Enable Latch (WEL) bit is reset. The Security Registers Lock Bit (LB) in the Status Register can be used to OTP protect the security registers. Once the LB bit is set to 1, the Security Registers will be permanently locked; the Erase Security Registers command will be ignored.

Address	A23-A16	A15-A10	A9-A0
Security Registers	00000000	000000	Don't Care

Figure 29. Erase Security Registers command Sequence Diagram

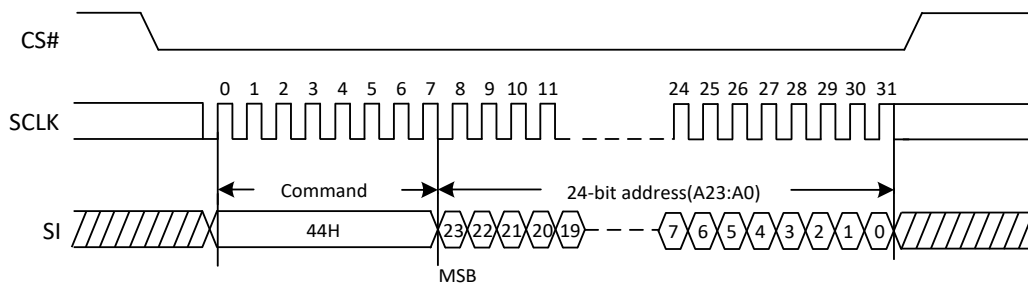

6.27. Program Security Registers (42H)

The Program Security Registers command is similar to the Page Program command. It allows from 1 to 256 bytes Security Registers data to be programmed. A Write Enable (WREN) command must previously have been executed to set the Write Enable Latch (WEL) bit before sending the Program Security Registers command. The Program Security Registers command is entered by driving CS# Low, followed by the command code (42H), three address bytes and at least one data byte on SI. As soon as CS# is driven high, the self-timed Program Security Registers cycle (whose duration is tPP) is initiated. While the Program Security Registers cycle is in progress, the Status Register may be read to check the value of the Write In Progress (WIP) bit. The Write In Progress (WIP) bit is 1 during the self-timed Program Security Registers cycle, and is 0 when it is completed. At some unspecified time before the cycle is completed, the Write Enable Latch (WEL) bit is reset.

If the Security Registers Lock Bit (LB) is set to 1, the Security Registers will be permanently locked. Program Security Registers command will be ignored.

Address	A23-A16	A15-A8	A7-A0
Security Registers 0	00H	00H	Byte Address
Security Registers 1	00H	01H	Byte Address
Security Registers 2	00H	02H	Byte Address
Security Registers 3	00H	03H	Byte Address

Figure 30. Program Security Registers command Sequence Diagram

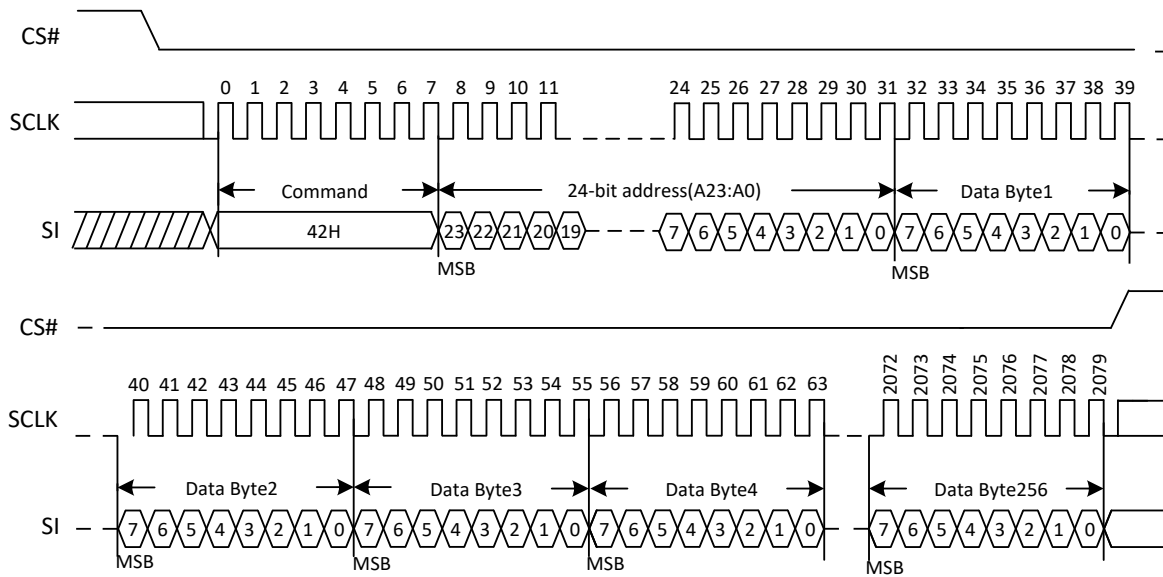

6.28. Read Security Registers (48H)

The Read Security Registers command is similar to Fast Read command. The command is followed by a 3-byte address (A23-A0) and a dummy byte, each bit being latched-in during the rising edge of SCLK. Then the memory content, at that address, is shifted out on SO, each bit being shifted out, at a Max frequency fC, during the falling edge of SCLK. The first byte addressed can be at any location. The address is automatically incremented to the next address after each byte of data is shifted out. Once the A9-A0 address reaches the last byte of the register (Byte 3FFH), it will reset to 000H, the command is completed by driving CS# high.

Address	A23-A16	A15-A10	A9-A0
Security Registers	00000000	000000	Address

Figure 31. Read Security Registers command Sequence Diagram

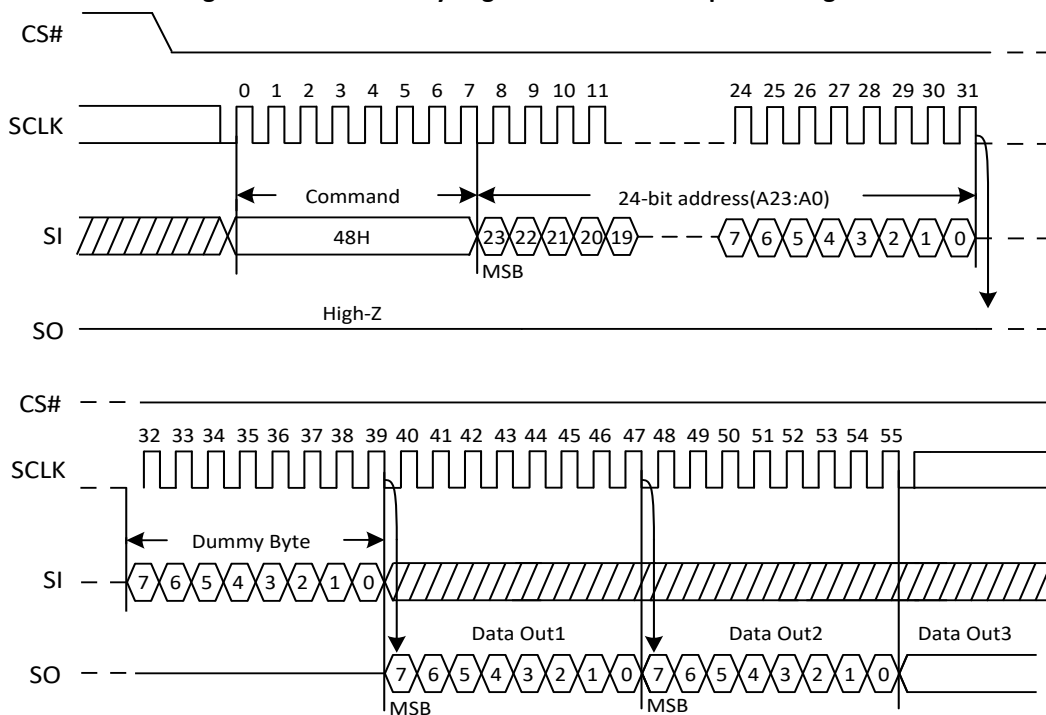

6.29. Set Read Parameters (COH)

In QPI mode the “Set Read Parameters (COH)” command can be used to configure the number of dummy clocks for “Fast Read (0BH)”, “Quad I/O Fast Read (EBH)” and “Burst Read with Wrap (0CH)” command, and to configure the number of bytes of “Wrap Length” for the “Burst Read with Wrap (0CH)” command. The “Wrap Length” is set by W5-6 bit in the “Set Burst with Wrap (77H)” command. This setting will remain unchanged when the device is switched from Standard SPI mode to QPI mode.

P5-P4	Dummy Clocks	Maximum Read Freq.	P1-P0	Wrap Length
0 0	4	54MHz	0 0	8-byte
0 1	4	54MHz	0 1	16-byte
1 0	6	54MHz	1 0	32-byte
1 1	8	54MHz	1 1	64-byte

Figure32. Set Read Parameters command Sequence Diagram

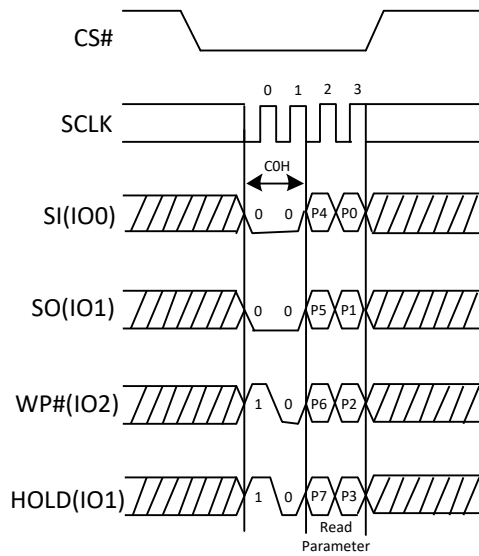

6.30. Burst Read with Wrap (0CH)

The “Burst Read with Wrap (0CH)” command provides an alternative way to perform the read operation with “Wrap Around” in QPI mode. This command is similar to the “Fast Read (0BH)” command in QPI mode, except the addressing of the read operation will “Wrap Around” to the beginning boundary of the “Wrap Around” once the ending boundary is reached. The “Wrap Length” and the number of dummy clocks can be configured by the “Set Read Parameters (C0H)” command. When the dummy cycle is configured to 4, addr[0] input must be 0.

Figure 33. Burst Read with Wrap command Sequence Diagram

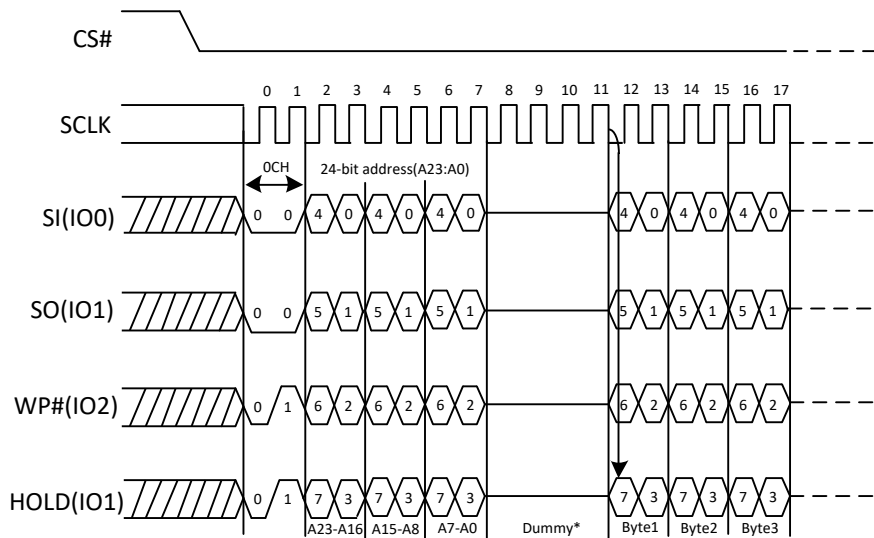

6.31. Enable QPI (38H)

The device support both Standard/Dual/Quad SPI and QPI mode. The “Enable QPI (38H)” command can switch the device from SPI mode to QPI mode. See the command Table 2a for all support QPI commands. In order to switch the device to QPI mode, the Quad Enable (QE) bit in Status Register-1 must be set to 1 first, and “Enable QPI (38H)” command must be issued. If the QE bit is 0, the “Enable QPI (38H)” command will be ignored and the device will remain in SPI mode. When the device is switched from SPI mode to QPI mode, the existing Write Enable Latch, and the Wrap Length setting will remain unchanged.

Figure 34. Enable QPI mode command Sequence Diagram

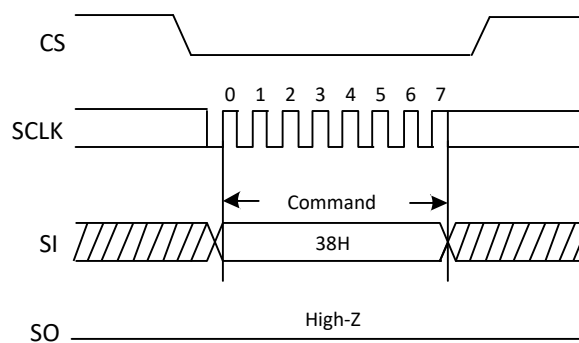

6.32. Continuous Read Mode Reset (CRMR) (FFH)/ Disable QPI (FFH)

The Dual/Quad I/O Fast Read operations, “Continuous Read Mode” bits (M7-0) are implemented to further reduce command overhead. By setting the (M7-0) to AXH, the next Dual/Quad I/O Fast Read operations do not require the BBH/EBH/E7H command code.

Because the XT25W32B has no hardware reset pin, so if Continuous Read Mode bits are set to “AXH”, the XT25W32B will not recognize any standard SPI commands. So Continuous Read Mode Reset command will release the Continuous Read Mode from the “AXH” state and allow standard SPI command to be recognized. The command sequence is show in Figure35.

Figure 35. Continuous Read Mode Reset Sequence Diagram

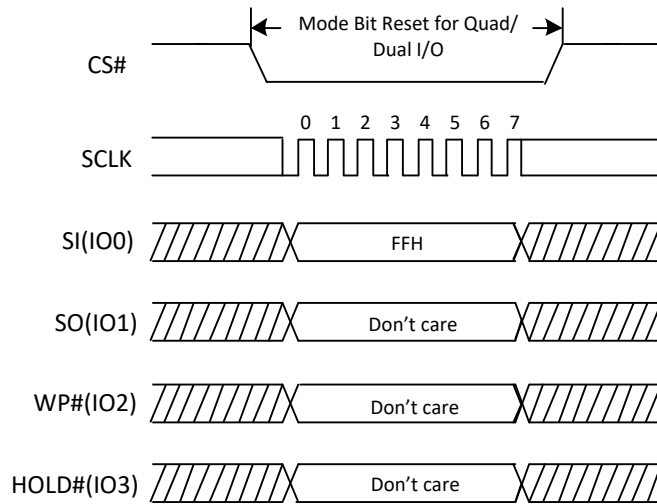

Disable QPI (FFH)

To exit the QPI mode and return to Standard/Dual/Quad SPI mode, the “Disable QPI (FFH)” command must be issued. When the device is switched from QPI mode to SPI mode, the existing Write Enable Latch and the Wrap Length setting will remain unchanged. When the device is in QPI mode, the first FFH command will exit continuous read mode and the second FFH command will exit QPI mode.

Figure 35a. Disable QPI mode command Sequence Diagram

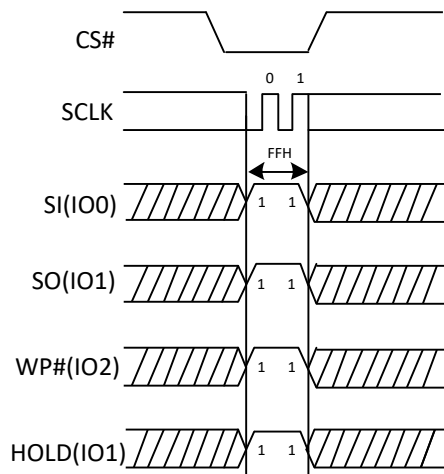

6.33. Enable Reset (66H) and Reset (99H)

If the Reset command is accepted, any on-going internal operation will be terminated and the device will return to its default power-on state and lose all the current volatile settings, such as Volatile Status Register bits, Write Enable Latch status (WEL), Read Parameter setting (P7-P0) and Wrap Bit Setting (W6-W4).

The “Reset (99H)” command sequence as follow: CS# goes low → Sending Enable Reset command → CS# goes high → CS# goes low → Sending Reset command → CS# goes high. Once the Reset command is accepted by the device, the device will take approximately tRST_R to reset. During this period, no command will be accepted. Data corruption may happen if there is an internal Erase or Program operation when Reset command sequence is accepted by the device. It is recommended to check the BUSY bit in Status Register before issuing the Reset command sequence.

Figure 36. Enable Reset and Reset command Sequence Diagram

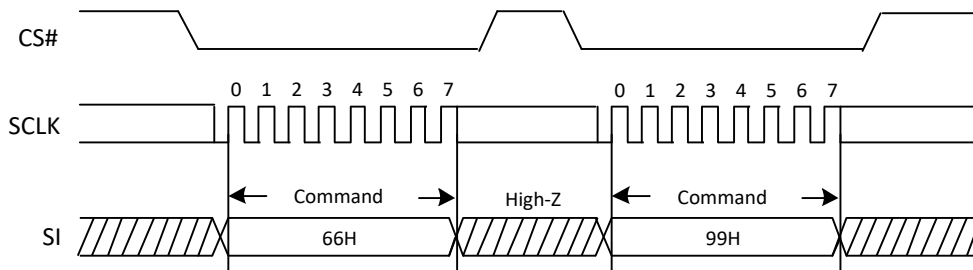
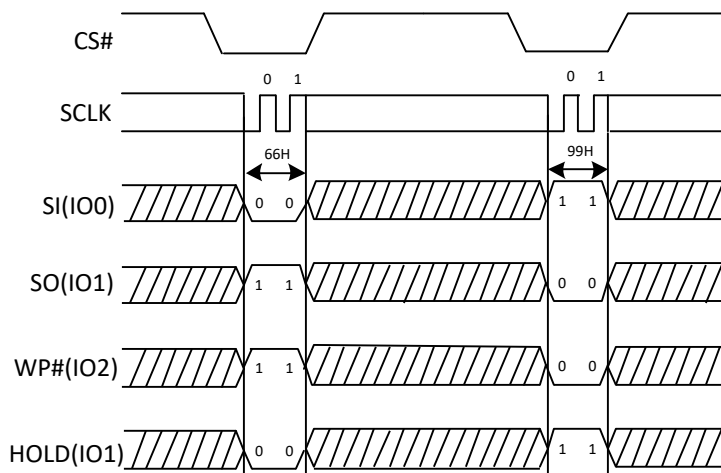

Figure 36a. Enable Reset and Reset command Sequence Diagram (QPI)



6.34. Read Serial Flash Discoverable Parameter (5AH)

The Serial Flash Discoverable Parameter (SFDP) standard provides a consistent method of describing the functional and feature capabilities of serial flash devices in a standard set of internal parameter tables. These parameter tables can be interrogated by host system software to enable adjustments needed to accommodate divergent features from multiple vendors. The concept is similar to the one found in the Introduction of JEDEC Standard, JESD68 on CFI. SFDP is a standard of JEDEC Standard No.216.

Figure 37. Read Serial Flash Discoverable Parameter command Sequence Diagram

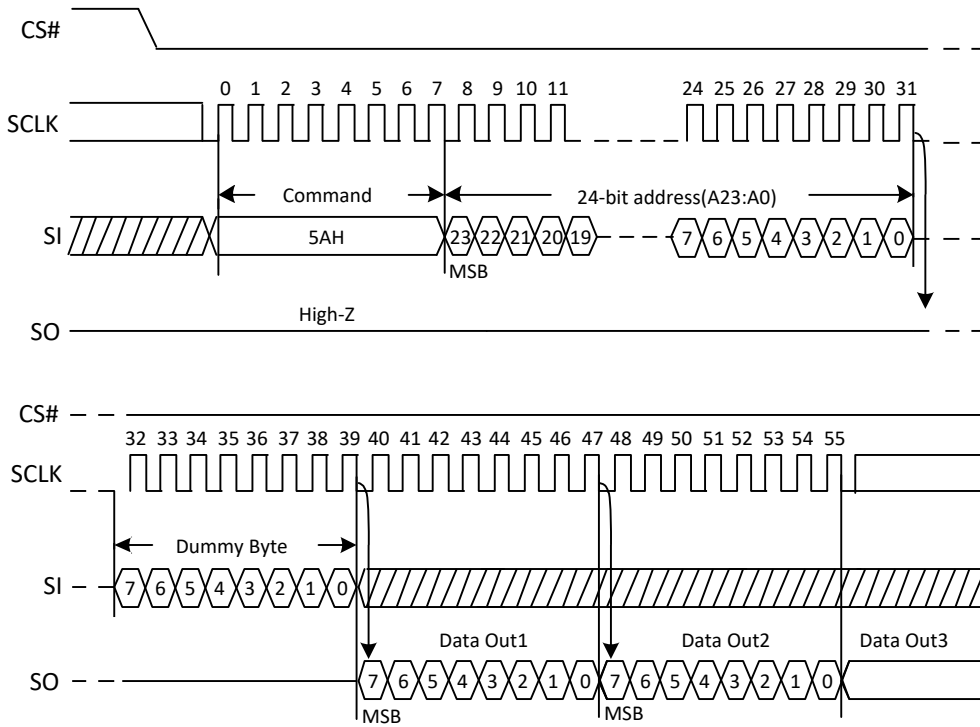
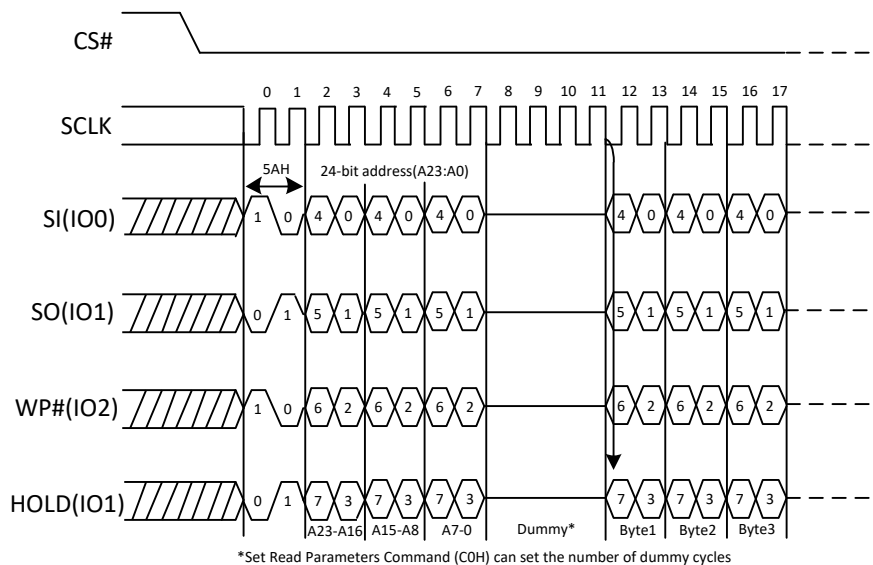

Figure 37a. Read Serial Flash Discoverable Parameter command Sequence Diagram (QPI)



*Set Read Parameters Command (C0H) can set the number of dummy cycles

6.35. Read Unique ID (5AH)

The Read Unique ID command accesses a factory-set read-only 128bit number that is unique to each XT25W32B device. The Unique ID can be used in conjunction with user software methods to help prevent copying or cloning of a system.

The Read Unique ID command sequence: CS# goes low → sending Read Unique ID command →00H →01H →94H → Dummy byte →128bit Unique ID Out → CS# goes high.

The command sequence is show below.

Figure 37.1. Read Unique ID (RUID) Sequence (Command 5AH)

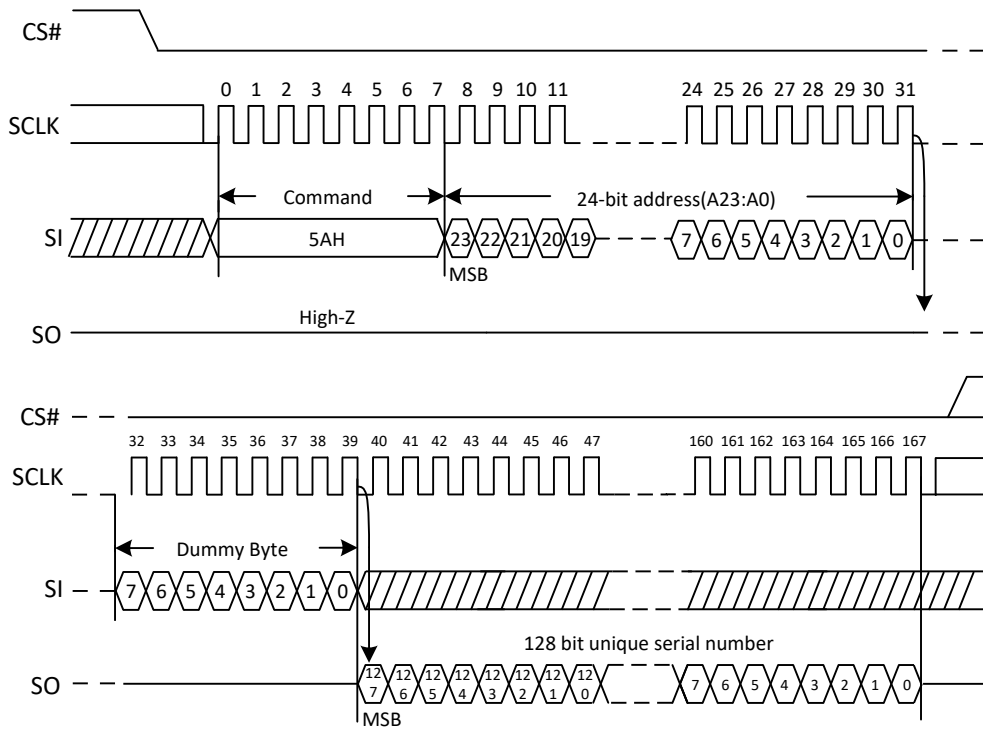



Table 4. Parameter Table (0): Signature and Parameter Identification Data Values

Description	Comment	Add(H) (Byte)	DW Add (Bit)	Data	Data
SFDP Signature	Fixed:50444653H	00H	07:00	53H	53H
		01H	15:08	46H	46H
		02H	23:16	44H	44H
		03H	31:24	50H	50H
SFDP Minor Revision Number	Start from 00H	04H	07:00	00H	00H
SFDP Major Revision Number	Start from 01H	05H	15:08	02H	02H
Number of Parameters Headers	Start from 00H	06H	23:16	01H	01H
Unused	Contains 0xFFH and can never be changed	07H	31:24	FFH	FFH
ID number (JEDEC)	00H: It indicates a JEDEC specified header	08H	07:00	00H	00H
Parameter Table Minor Revision Number	Start from 0x00H	09H	15:08	00H	00H
Parameter Table Major Revision Number	Start from 0x01H	0AH	23:16	02H	02H
Parameter Table Length (in double word)	How many DWORDs in the Parameter table	0BH	31:24	09H	09H
Parameter Table Pointer (PTP)	First address of JEDEC Flash Parameter table	0CH	07:00	30H	30H
		0DH	15:08	00H	00H
		0EH	23:16	00H	00H
Unused	Contains 0xFFH and can never be changed	0FH	31:24	FFH	FFH
ID Number (XTX Manufacturer ID)	It indicates XTX manufacturer ID	10H	07:00	0BH	0BH
Parameter Table Minor Revision Number	Start from 0x00H	11H	15:08	00H	00H
Parameter Table Major Revision Number	Start from 0x01H	12H	23:16	02H	02H
Parameter Table Length (in double word)	How many DWORDs in the Parameter table	13H	31:24	03H	03H
Parameter Table Pointer (PTP)	First address of XTX Flash Parameter table	14H	07:00	60H	60H
		15H	15:08	00H	00H
		16H	23:16	00H	00H
Unused	Contains 0xFFH and can never be changed	17H	31:24	FFH	FFH



Parameter Table (1): JEDEC Flash Parameter Tables

Description	Comment	Add(H) (Byte)	DW Add (Bit)	Data	Data
Block/Sector Erase Size	00: Reserved; 01: 4KB erase; 10: Reserved; 11: not support 4KB erase	30H	01:00	01b	E5H
Write Granularity	0: 1Byte, 1: 64Byte or larger		02	1b	
Write Enable Instruction Requested for Writing to Volatile Status Registers	0: Nonvolatile status bit 1: Volatile status bit (BP status register bit)		03	0b	
Write Enable Opcode Select for Writing to Volatile Status Registers	0: Use 50H Opcode, 1: Use 06H Opcode, Note: If target flash status register is Nonvolatile, then bits 3 and 4 must be set to 00b.		04	0b	
Unused	Contains 111b and can never be changed		07:05	111b	
4KB Erase Opcode		31H	15:08	20H	20H
(1-1-2) Fast Read	0=Not support, 1=Support	32H	16	1b	F1H
Address Bytes Number used in addressing flash array	00: 3Byte only, 01: 3 or 4Byte, 10: 4Byte only, 11: Reserved		18:17	00b	
Double Transfer Rate (DTR) clocking	0=Not support, 1=Support		19	0b	
(1-2-2) Fast Read	0=Not support, 1=Support		20	1b	
(1-4-4) Fast Read	0=Not support, 1=Support		21	1b	
(1-1-4) Fast Read	0=Not support, 1=Support		22	1b	
Unused			23	1b	
Unused			33H	31:24	
Flash Memory Density		37H:34H	31:00	01FFFFFFH	
(1-4-4) Fast Read Number of Wait states	0 0000b: Wait states (Dummy Clocks) not support (M7-M0 excluded)	38H	04:00	00100b	44H
(1-4-4) Fast Read Number of Mode Bits	000b:Mode Bits not support		07:05	010b	
(1-4-4) Fast Read Opcode		39H	15:08	EBH	EBH
(1-1-4) Fast Read Number of Wait states	0 0000b: Wait states (Dummy Clocks) not support	3AH	20:16	01000b	08H
(1-1-4) Fast Read Number of Mode Bits	000b:Mode Bits not support		23:21	000b	
(1-1-4) Fast Read Opcode		3BH	31:24	6BH	6BH



Description	Comment	Add(H) (Byte)	DW Add (Bit)	Data	Data
(1-1-2) Fast Read Number of Wait states	0 0000b: Wait states (Dummy Clocks) not support	3CH	04:00	01000b	08H
(1-1-2) Fast Read Number of Mode Bits	000b: Mode Bits not support		07:05	000b	
(1-1-2) Fast Read Opcode		3DH	15:08	3BH	3BH
(1-2-2) Fast Read Number of Wait states	0 0000b: Wait states (Dummy Clocks) not support (M7-M0 excluded)	3EH	20:16	000000b	40H
(1-2-2) Fast Read Number of Mode Bits	000b: Mode Bits not support 010b: 8bit Mode Bits = 2 dummy clocks (M7-M0)		23:21	010b	
(1-2-2) Fast Read Opcode		3FH	31:24	BBH	BBH
(2-2-2) Fast Read	0=not support 1=support	40H	00	0b	FEH
Unused			03:01	111b	
(4-4-4) Fast Read	0=not support 1=support		04	1b	
Unused			07:05	111b	
Unused		43H:41H	31:08	0xFFH	0xFFH
Unused		45H:44H	15:00	0xFFH	0xFFH
(2-2-2) Fast Read Number of Wait states	0 0000b: Wait states (Dummy Clocks) not support	46H	20:16	00000b	00H
(2-2-2) Fast Read Number of Mode Bits	000b: Mode Bits not support		23:21	000b	
(2-2-2) Fast Read Opcode		47H	31:24	FFH	FFH
Unused		49H:48H	15:00	0xFFH	0xFFH
(4-4-4) Fast Read Number of Wait states	0 0000b: Wait states (Dummy Clocks) not support (M7-M0 included)	4AH	20:16	01000b	48H
(4-4-4) Fast Read Number of Mode Bits	000b: Mode Bits not support 010b: 8bit Mode Bits = 2 dummy clocks (M7-M0)		23:21	010b	
(4-4-4) Fast Read Opcode		4BH	31:24	EBH	EBH
Sector Type 1 Size	Sector/block size=2 ^N Bytes 0x00b: this sector type don't exist	4CH	07:00	0CH	0CH
Sector Type 1 erase Opcode		4DH	15:08	20H	20H
Sector Type 2 Size	Sector/block size=2 ^N Bytes 0x00b: this sector type don't exist	4EH	23:16	0FH	0FH
Sector Type 2 erase Opcode		4FH	31:24	52H	52H
Sector Type 3 Size	Sector/block size=2 ^N Bytes 0x00b: this sector type don't exist	50H	07:00	10H	10H
Sector Type 3 erase Opcode		51H	15:08	D8H	D8H
Sector Type 4 Size	Sector/block size=2 ^N Bytes 0x00b: this sector type don't exist	52H	23:16	00H	00H
Sector Type 4 erase Opcode		53H	31:24	FFH	FFH



Parameter Table (2): XTX Flash Parameter Tables

Description	Comment	Add(H) (Byte)	DW Add (Bit)	Data	Data
Vcc Supply Maximum Voltage	2000H=2.000V 2700H=2.700V 3600H=3.600V	61H:60H	15:00	3600H	3600H
Vcc Supply Minimum Voltage	1650H=1.650V 2250H=2.250V 2350H=2.350V 2700H=2.700V	63H:62H	31:16	1650H	1650H
HW Reset# pin	0=not support 1=support	65H:64H	00	0b	C99EH
HW Hold# pin	0=not support 1=support		01	1b	
Deep Power Down Mode	0=not support 1=support		02	1b	
SW Reset	0=not support 1=support		03	1b	
SW Reset Opcode	Should be issue Reset Enable(66H) before Reset cmd.		11:04	1001 1001b (99H)	
Program Suspend/Resume	0=not support 1=support		12	0b	
Erase Suspend/Resume	0=not support 1=support		13	0b	
Unused			14	1b	
Wrap-Around Read mode	0=not support 1=support		15	1b	
Wrap-Around Read mode Opcode		66H	23:16	FFH	FFH
Wrap-Around Read data length	08H:support 8B wrap-around read 16H:8B&16B 32H:8B&16B&32B 64H:8B&16B&32B&64B	67H	31:24	64H	64H
Individual block lock	0=not support 1=support	6BH:68H	00	0b	EBFCH
Individual block lock bit (Volatile/Nonvolatile)	0=Volatile 1=Nonvolatile		01	0b	
Individual block lock Opcode			09:02	FFH	
Individual block lock Volatile protect bit default protect status	0=protect 1=unprotect		10	0b	
Secured OTP	0=not support 1=support		11	1b	
Read Lock	0=not support 1=support		12	0b	
Permanent Lock	0=not support 1=support		13	1b	
Unused			15:14	11b	
Unused			31:16	FFFFH	

7. ELECTRICAL CHARACTERISTICS

7.1. Power-on Timing

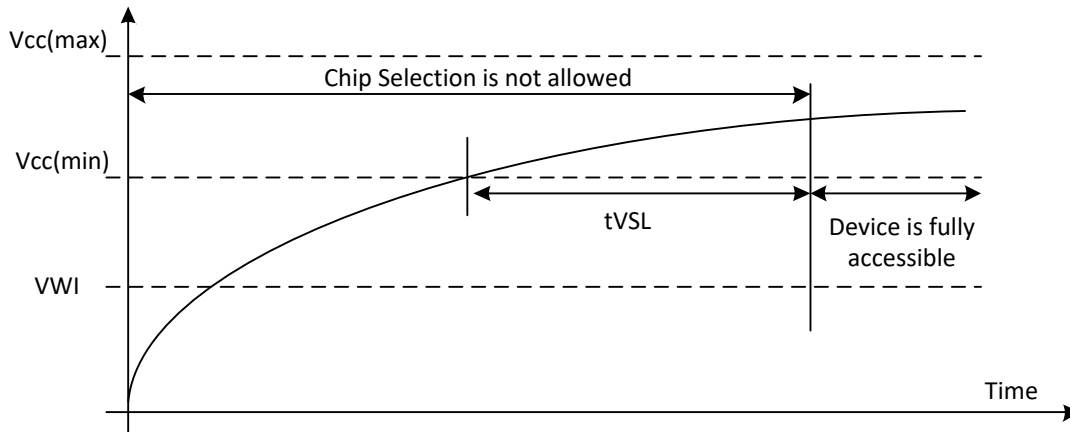

Table3. Power-Up Timing and Write Inhibit Threshold

Note: At power-down, need to ensure VCC drop to 0.5V before the next power-on in order for the device to have a proper power-on reset.

Symbol	Parameter	Min	Max	Unit
t_{VSL}	VCC(min) To CS# Low	10		us
V_{WI}	Write Inhibit Voltage	-	1.5	V

7.2. Initial Delivery State

The device is delivered with the memory array erased: all bits are set to 1(each byte contains FFH).The Status Register contains 00H (all Status Register bits are 0).

7.3. Data Retention and Endurance

Parameter	Typical	Unit
Data Retention Time	20	Years
Erase/Program Endurance	100K	Cycles

7.4. Latch up Characteristics

Parameter	Min	Max
Input Voltage Respect To VSS On I/O Pins	-1.0V	VCC+1.0V
VCC Current	-100mA	100mA

7.5. Absolute Maximum Ratings

Parameter	Value	Unit
Ambient Operating Temperature	-40 to 85	°C
Storage Temperature	-65 to 150	°C
Output Short Circuit Current	200	mA
Applied Input/Output Voltage	-0.5 to 4.0	V
VCC	-0.5 to 4.0	V

7.6. Capacitance Measurement Condition

Symbol	Parameter	Min	Typ	Max	Unit	Conditions
CIN	Input Capacitance			6	pF	VIN=0V
COUT	Output Capacitance			8	pF	VOUT=0V
CL	Load Capacitance		30		pF	
	Input Rise And Fall time			5	ns	
	Input Pulse Voltage	0.1VCC to 0.8VCC			V	
	Input Timing Reference Voltage	0.2VCC to 0.7VCC			V	
	Output Timing Reference Voltage		0.5VCC		V	

Figure38. Input Test Waveform and Measurement Level

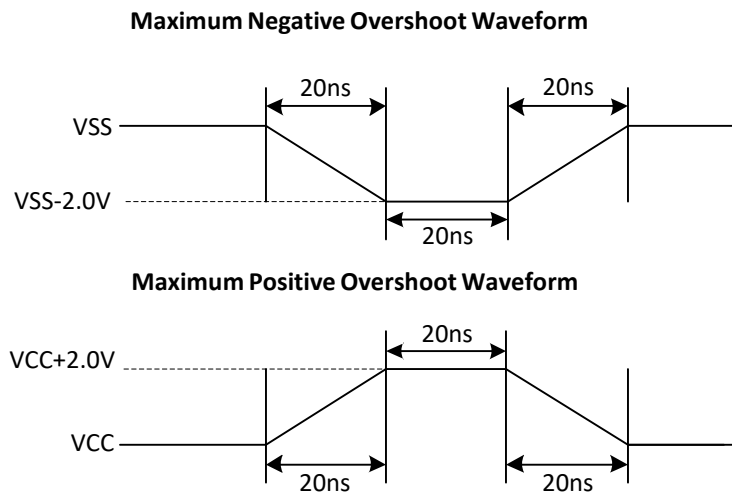

7.7. DC Characteristics

(T=-40°C~85°C, VCC=1.65~3.6V)

Symbol	Parameter	Test Condition	Min.	Typ	Max.	Unit
I _{LI}	Input Leakage Current ⁽¹⁾				±2	μA
I _{LO}	Output Leakage Current ⁽¹⁾				±2	μA
I _{CC1}	Standby Current	CS#=VCC VIN=VCC or VSS		12	40	μA
I _{CC2}	Deep Power-Down Current	CS#=VCC VIN=VCC or VSS		0.1	4	μA
I _{CC3}	Operating Current(Read) ⁽²⁾	CLK=0.1VCC/0.9VCC at 80MHz, Q=Open(*1, *2, *4 I/O)		13	18	mA
		CLK=0.1VCC/0.9VCC at 50MHZ, Q=Open(*1, *2, *4 I/O)		7	10	mA
I _{CC4}	Operating Current(PP)	CS#=VCC			30	mA
I _{CC5}	Operating Current(WRSR)	CS#=VCC			30	mA
I _{CC6}	Operating Current(SE)	CS#=VCC			30	mA
I _{CC7}	Operating Current(BE)	CS#=VCC			30	mA
V _{IL}	Input Low Voltage		-0.5		0.2VCC	V
V _{IH}	Input High Voltage		0.7VCC		VCC+0.4	V
V _{OL}	Output Low Voltage	IOL=1.6mA			0.4	V
V _{OH}	Output High Voltage	IOH=-100uA	VCC-0.2			V

Notes:

1. Tested on sample basis and specified through design and characterization data. TA = 25° C, VCC = 3.3V.
2. Pattern 00 FF.

7.8. AC Characteristics

(T=-40°C~85°C, VCC=1.65~3.6V, C_L=30pF)

Symbol	Parameter	Min.	Typ.	Max	Unit
fC	Serial Clock Frequency For: Read Data(03H), Fast Read (0BH), Dual Output(3BH), Dual I/O (BBH), Quad I/O(EBH), Quad Output(6BH) under 1.65V~2.1V			56	MHz
fC1	Serial Clock Frequency For: Read Data(03H), Fast Read (0BH), Dual Output(3BH), Dual I/O (BBH), Quad I/O(EBH), Quad Output(6BH) under 2.1V~3.6V			80	MHz
fC2	Serial Clock Frequency For QPI (0BH, EBH)			45	MHz
tCLH	Serial Clock High Time	45% PC			ns
tCLL	Serial Clock Low Time	45% PC			ns
tCLCH	Serial Clock Rise Time(Slew Rate)	0.2			V/ns
tCHCL	Serial Clock Fall Time(Slew Rate)	0.2			V/ns
tSLCH	CS# Active Setup Time	5			ns
tCHSH	CS# Active Hold Time	5			ns
tSHCH	CS# Not Active Setup Time	5			ns
tCHSL	CS# Not Active Hold Time	5			ns
tSHSL	CS# High Time (read/write)	30			ns
tSHQZ	Output Disable Time			6	ns
tCLQX	Output Hold Time	1			ns
tDVCH	Data In Setup Time	2			ns
tCHDX	Data In Hold Time	2			ns
tHLCH	Hold# Low Setup Time(relative to Clock)	5			ns
tHHCH	Hold# High Setup Time(relative to Clock)	5			ns
tCHHL	Hold# High Hold Time(relative to Clock)	5			ns
tCHHH	Hold# Low Hold Time(relative to Clock)	5			ns
tCLQV	Clock Low To Output Valid			10	ns
tWHSL	Write Protect Setup Time Before CS# Low	20			ns
tSHWL	Write Protect Hold Time After CS# High	100			ns
tDP	CS# High To Deep Power-Down Mode			0.1	μs
tRES1	CS# High To Standby Mode Without Electronic Signature Read			20	μs
tRES2	CS# High To Standby Mode With Electronic Signature Read			20	μs
tRST_R	CS# High To Next Command After Reset (from read)			20	μs
tRST_P	CS# High To Next Command After Reset (from program)			20	μs
tRST_E	CS# High To Next Command After Reset (from erase)			12	ms
tW	Write Status Register Cycle Time		100	2000	ms
tPP	Page Programming Time		2	5	ms
tSE	Sector Erase Time		100	2000	ms
tBE1	Block Erase Time(32K Bytes)		0.5	1.5	s
tBE2	Block Erase Time(64K Bytes)		0.7	2.5	s



tCE	Chip Erase Time		38	70	s
-----	-----------------	--	----	----	---

Note:

1. Clock high or Clock low must be more than or equal to 45%Pc. $Pc=1/fC(\text{MAX})$
2. Typical values given for $T_A=25^\circ\text{C}$. Value guaranteed by design and/or characterization, are not 100% tested in production.
3. Maximum Serial Clock Frequencies are measured results picked at the falling edge, for Serial Clock Frequencies picked at the rising edge, refer to the following diagram:

Maximum Serial Clock Frequencies Picked At The Rising Edge

Symbol	Parameter	Min.	Typ.	Max	Unit
fC	Serial Clock Frequency For: Read Data(03H), Fast Read (0BH), Dual Output(3BH), Dual I/O (BBH), Quad I/O(EBH), Quad Output(6BH) under 1.65V~2.1V			40	MHz
fC1	Serial Clock Frequency For: Read Data(03H), Fast Read (0BH), Dual Output(3BH), Dual I/O (BBH), Quad I/O(EBH), Quad Output(6BH) under 2.1V~3.6V			60	MHz

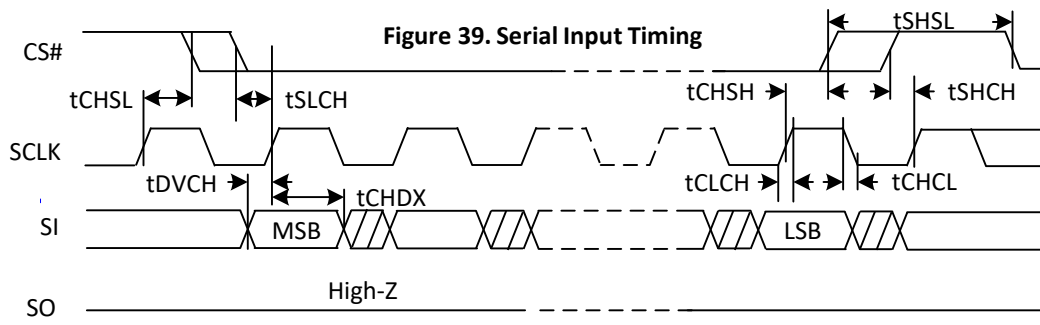

Figure 40. Output Timing

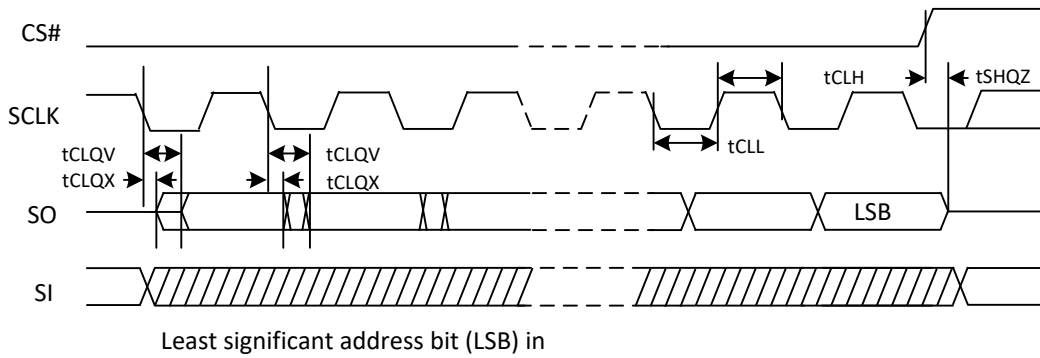
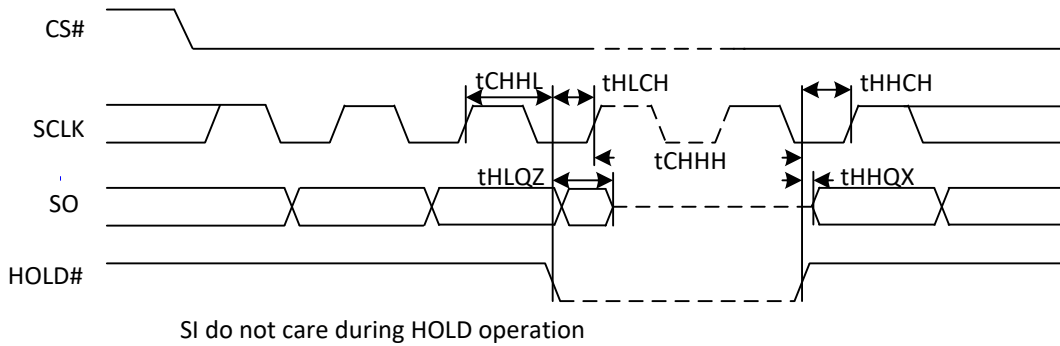

Figure 41. Hold Timing



NOTE:

Standard bulk shipment is in Tube. Any alternation of packing method (for Tape, Reel and Tray etc.), please advise in advance.

8. ORDERING INFORMATION

The ordering part number is formed by a valid combination of the following

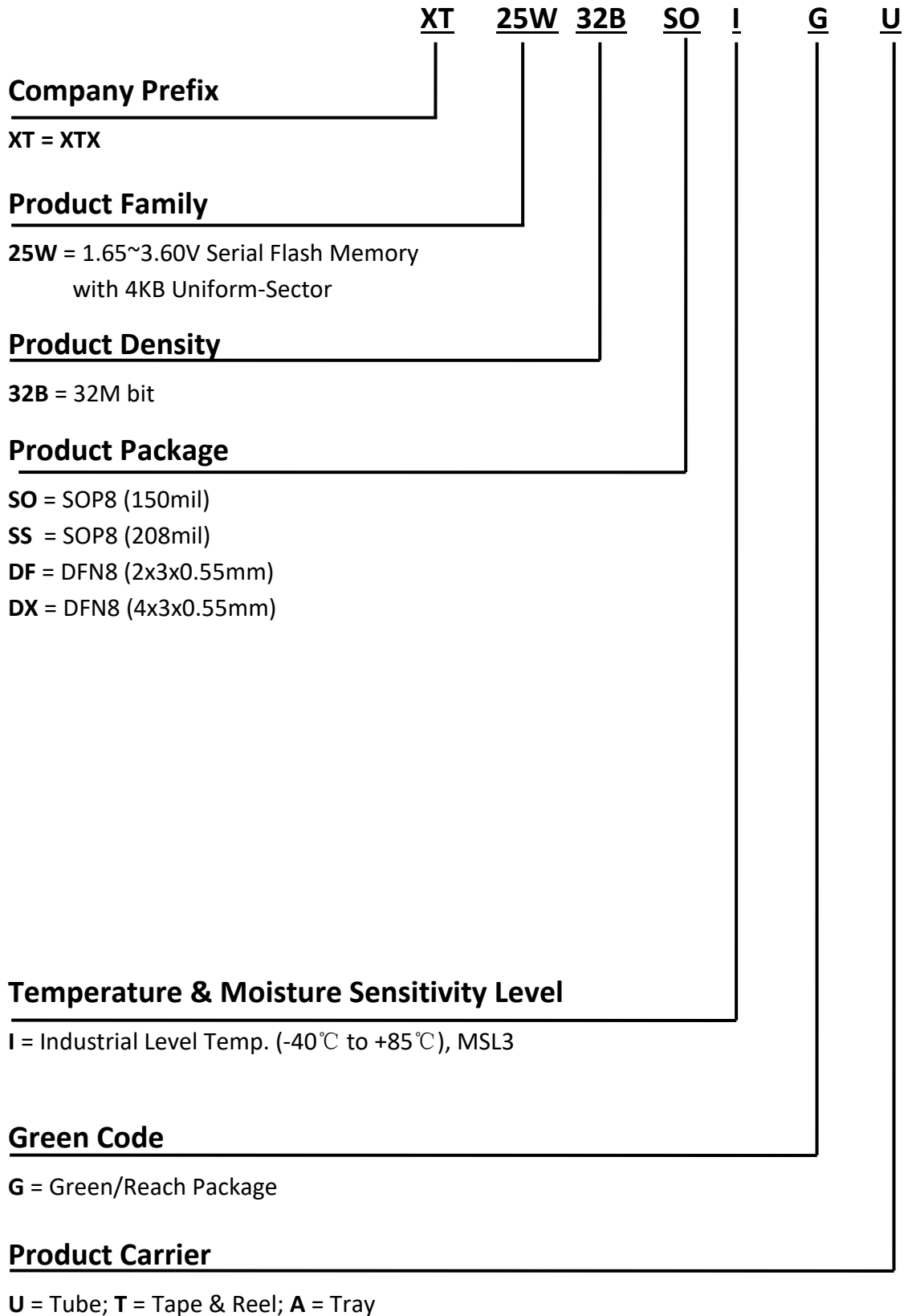

9. PACKAGE INFORMATION

9.1. Package SOP8 150MIL

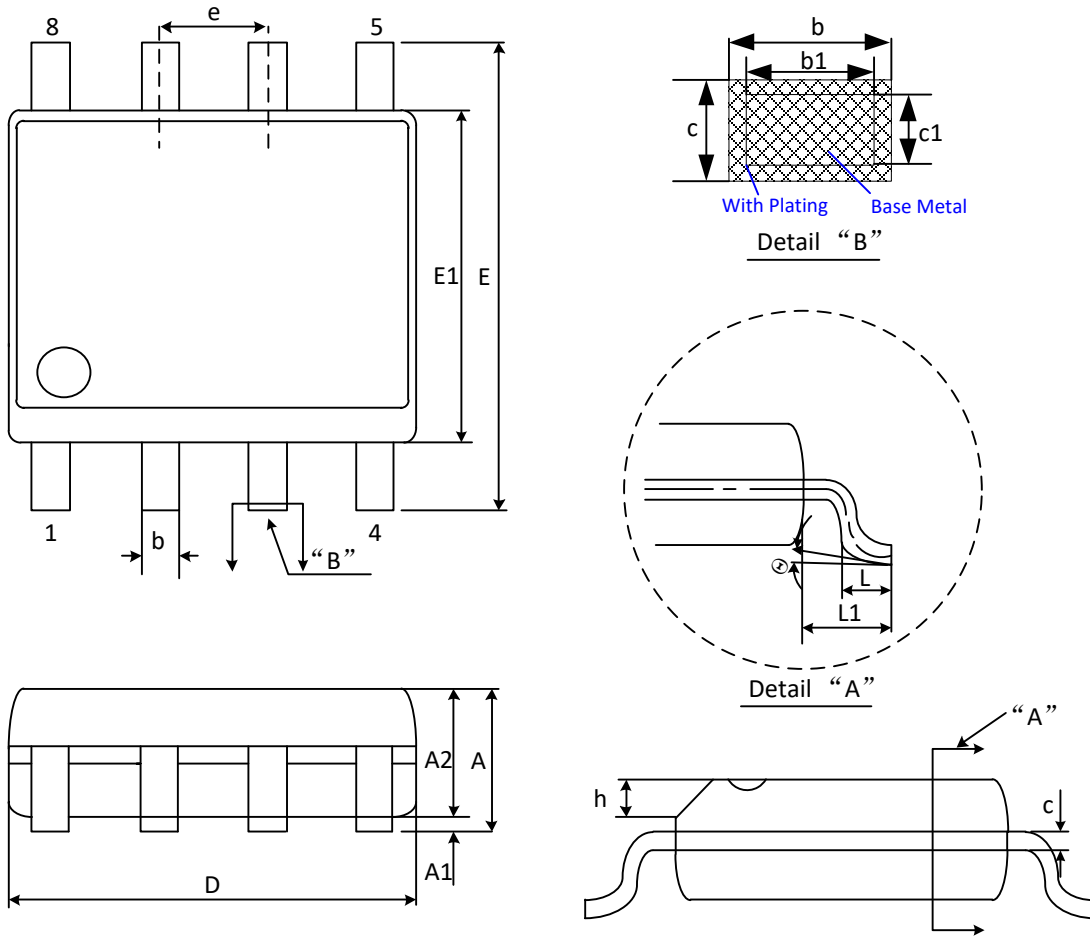

SYMBOL	MILLIMETER		
	MIN	NOM	MAX
A	—	—	1.75
A1	0.10	—	0.25
A2	1.30	1.40	1.50
b	0.39	—	0.47
b1	0.38	0.41	0.44
c	0.20	—	0.24
c1	0.19	0.20	0.21
D	4.80	4.90	5.00
E1	3.80	3.90	4.00
e	1.27BSC		
E	5.80	6.00	6.20
h	0.25	—	0.50
L	0.50	—	0.80
L1	1.05REF		
θ	0°	—	8°

9.2. Package SOP8 208MIL

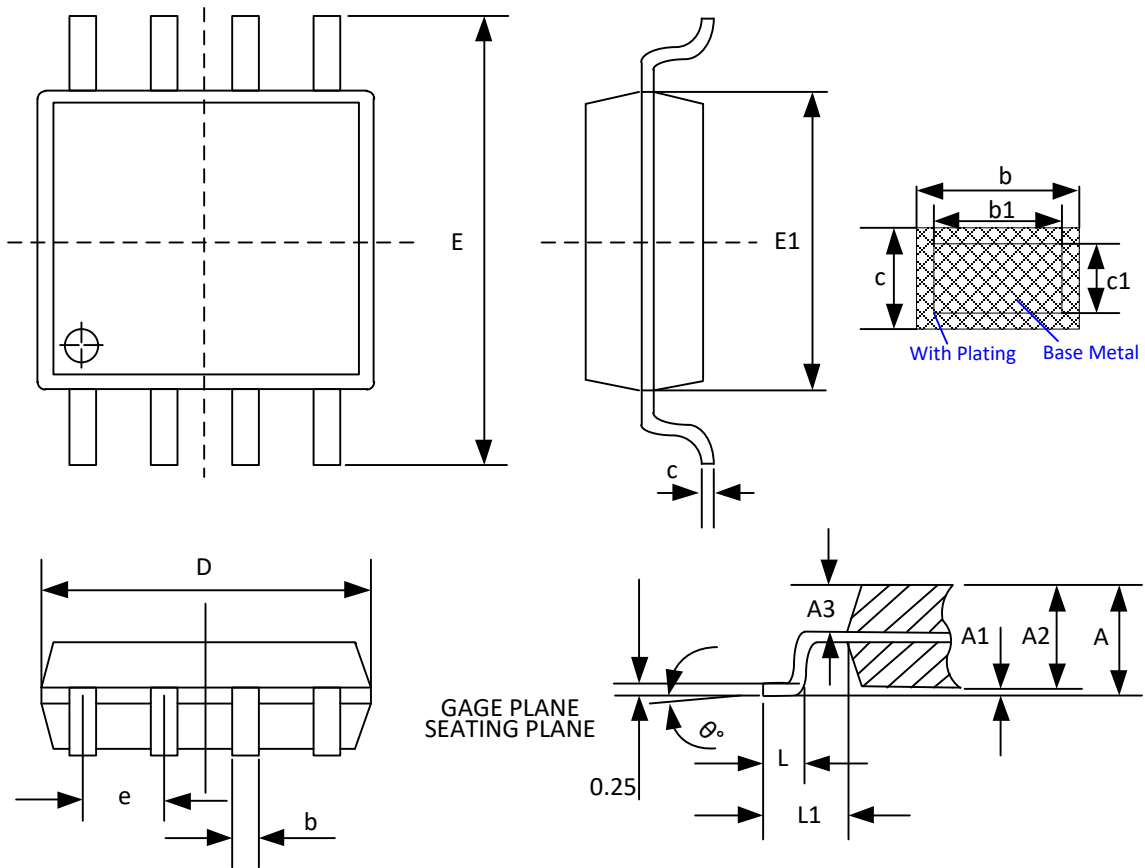

SYMBOL	MILLIMETER		
	MIN	NOM	MAX
A	1.75	1.95	2.15
A1	0.05	0.15	0.25
A2	1.70	1.80	1.90
A3	0.75	0.80	0.85
b	0.33	—	0.51
b1	0.30	—	0.48
c	0.17	—	0.25
c1	0.15	0.20	0.23
D	5.13	5.23	5.33
E	7.70	7.90	8.10
E1	5.18	5.28	5.38
e	1.27 BSC		
L	0.50	0.65	0.80
L1	1.31 REF		
θ	0°	—	8°

9.3. Package DFN8 (2x3x0.55) mm

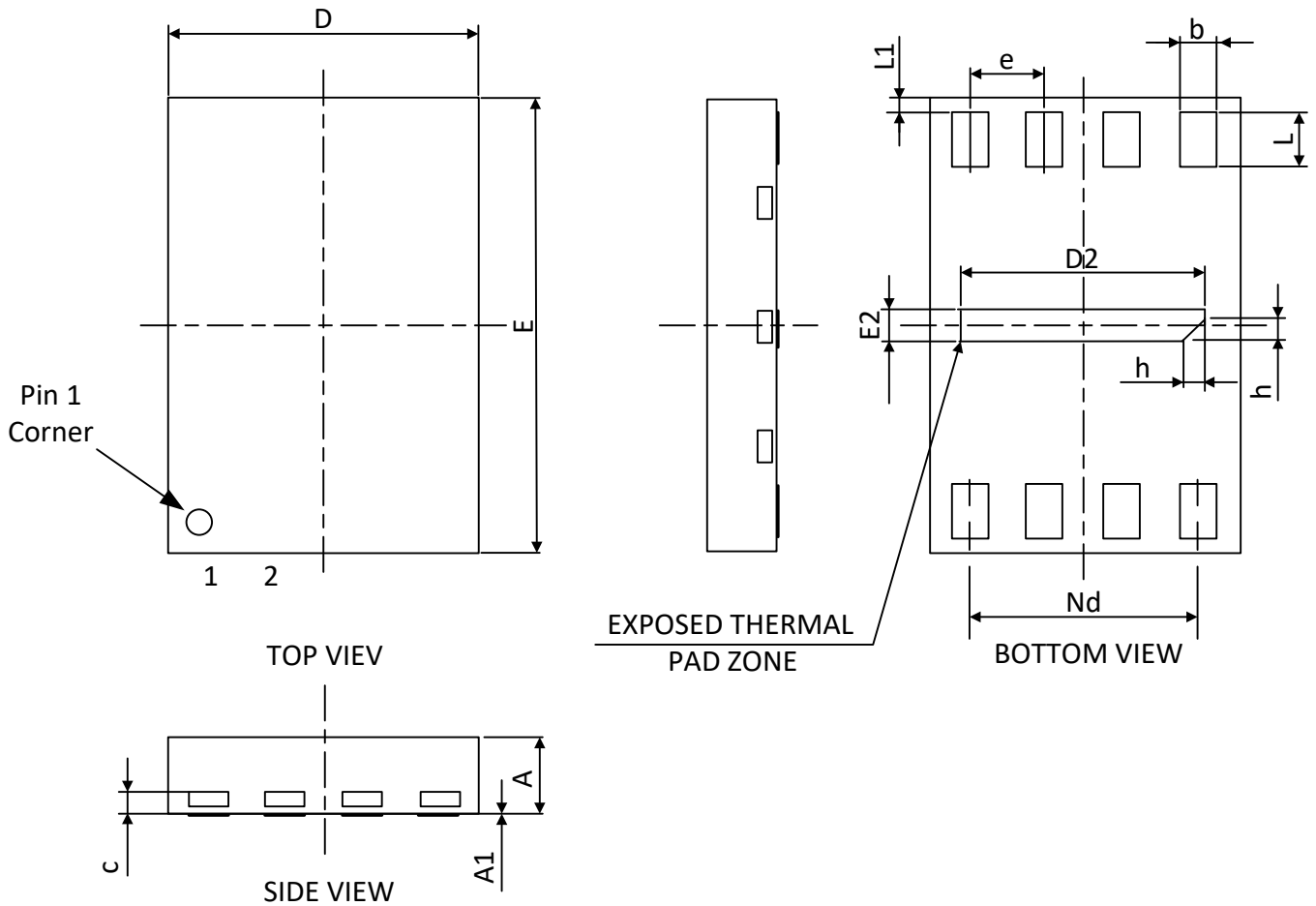

Symbol	Dimensions in Millimeters		
	Min	Norm	Max
A	0.50	0.55	0.60
A1	0	0.02	0.05
b	0.18	0.25	0.30
c	0.10	0.15	0.20
D	1.90	2.00	2.10
D2	1.50	1.60	1.70
e	0.50 BSC		
Nd	1.50 BSC		
E	2.90	3.00	3.10
E2	0.10	0.20	0.30
L	0.30	0.35	0.40
L1	0.05	0.10	0.15
h	0.05	0.15	0.25

9.4. Package DFN8 (4x3x0.55) mm

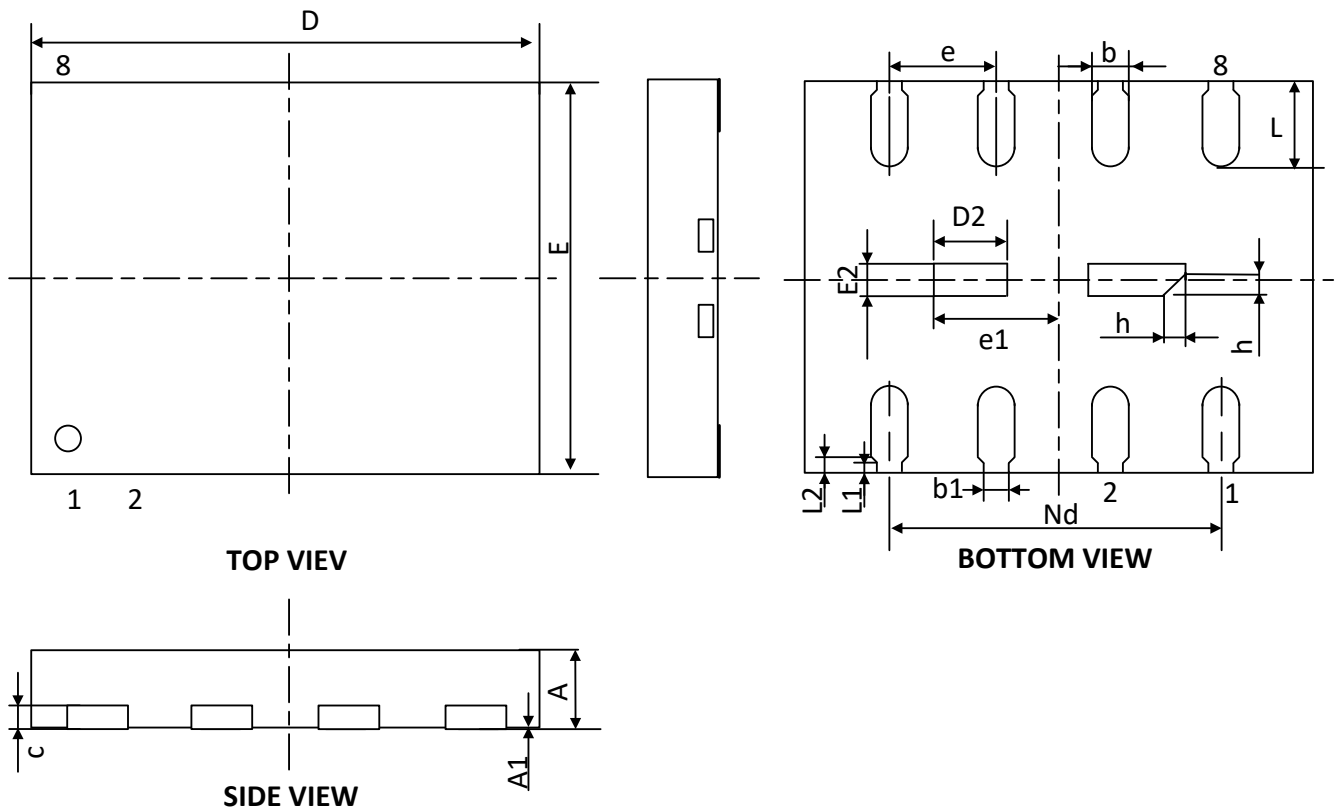

SYMBOL	MILLIMETER		
	MIN	NOM	MAX
A	0.50	0.55	0.60
A1	0	0.02	0.05
b	0.25	0.30	0.35
b1	0.20 REF		
c	0.10	0.15	0.20
D	3.90	4.00	4.10
D2	0.70	0.80	0.90
e	0.80 BSC		
e1	0.80 BSC		
Nd	2.40 BSC		
E	2.90	3.00	3.10
E2	0.10	0.20	0.30
L	0.55	0.60	0.65
L1	0.05 REF		
L2	0.10 REF		
h	0.10	0.15	0.20

10. REVISION HISTORY

Revision	Description	Date
0.0	Initial version	Apr 03, 2018
0.1	Revise page 3,4, 49, 61 & 62 for read speed, clock & erase/program time	Apr-18-2018
0.2	Revise to include BGA OPN with permanent register lock	May-03-2018
0.3	Revise to include WLCSP package type OPN for ordering and change max tSE time to 300mS	May-09-2018
0.4	Revise to include BGA16 package type OPN for ordering	May-29-2018
0.5	Revise to include QFN16 package type OPN for ordering & correct (44H) command description at page #47.	Jun-21-2018
0.6	Revise to correct typo t_{VSL} timing mS to μ S at page #59, add support SFDP & UID features and industrial plus grade OPN.	Jul-27-2018
0.7	Revise to modify format	Aug-15-2018
0.8	Revise "FR" serial clock frequency for read ID (90H), remove company address.	Aug-30-2018
0.9	Revise mistake of maximum clock frequency in DC Characteristics	Sep-21-2018
1.0	Revise to change advance security feature from 3x256 to 4x 256byte at page#2 and change 42H command description security register table at page#46.	Nov-08-2018
1.1	Revise to include UID command & description at page #17, 54 and remove Erase/program resume/suspend command at page #45-47, 17&18.	Dec-05-2018
1.2	Correct typo for voltage range at DC and AC Characteristics table, correct typo on security registers address description , revise page programing time and QPI mode read speed.	Jun-11-2019
1.3	Updated 7.1 Power-on timing description and figure	Aug-30-2019
1.4	Adjust AC Characteristics diagram and AC\DC performance, deleted high temperature OPNs.	Nov-5-2019
1.5	Adjust operation current to 30mA. DPD maximum change from 0.2uA to 4uA. Standby maximum changed from 20uA to 40uA. Read Current at 50Mhz changed from 5/7mA to 7/10mA Deleted tHLQZ, tHHQX, and updated description of Hold in Device Operation.	Mar-30-2020
1.6	Updated QPI diagrams style Deleted DFN8 2x3x0.4mm Package Adjust read speed and maximum WRSR time to 2000ms Corrected page program time and chip erase time in feature page to match the AC Characteristic. Updated SFDP Table mistakes of DW Add 37H:34H, 3EH:4AH, 61H:68H	Sep-18-2020
1.7	Updated POD of SOP8 150mil, SOP8 208mil, DFN8(2x3x0.4)mm, DFN8(4x3x0.55)mm Changed Logo and company name	Apr-2-2021