

TSD025\*\*\*\*\*

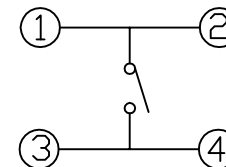

电路图  
CIRCUIT DIAGRAM

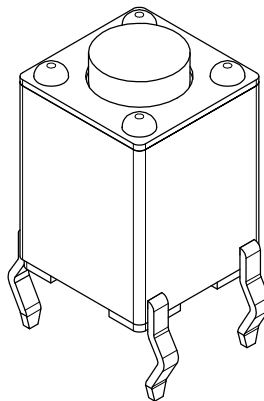
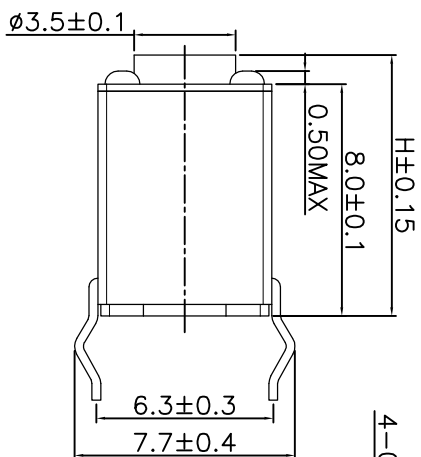
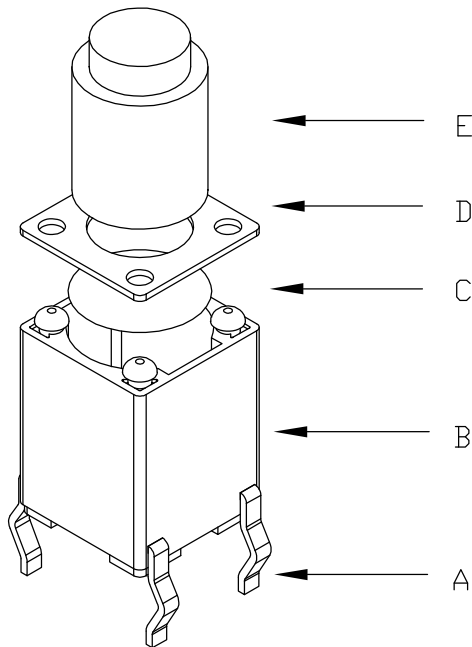
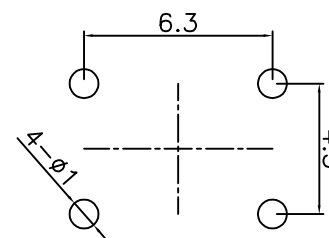

PCB. 焊接图  
PCB. WELDING DRAWING

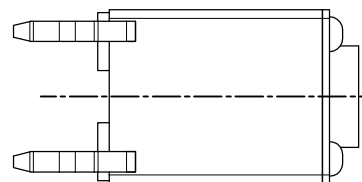
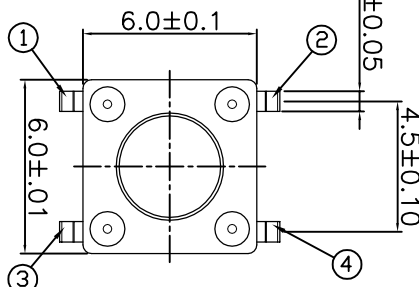

主要技术参数、性能

The Main Thchnology Performance

额定电流、电压 Rate voltage,current	50mA DC12V
接触电阻 Contact resistance	$\leq 100\text{m}\Omega$
按力 Operating force	$\pm 50\text{gf}$
行程 Travel	$0.20 \pm 0.10\text{mm}$
绝缘电阻 Insulated resistance	$\geq 100\text{M}\Omega$
介电强度 Dielectric strength	$\geq 250\text{VAC}/1\text{min}$

TSD025

寿命:  
A:  $\geq 300000$ 次  
B:  $\geq 1000000$ 次  
C:  $\geq 3000000$ 次

高度H:  
110:11.0H  
115:11.5H  
120:12.0H  
125:12.5H  
130:13.0H  
...

力度:  
18:180g  
26:260g  
35:350g

包装方式:  
A:散件

E	按钮	PPA	1	黑色
D	盖板	铁盖板	1	镀铜锡
C	弹片	不锈钢	1	镀银
B	本体	PPA	1	黑色
A	卡件	黄铜	1	镀银
项目 ITEM	名称 DESCRIPTION	材质 MATERIAL	数量 QTY	表面处理/颜色 FINSH/COLOR

					第一视角 FIRST VIEW		名称/NAME: 轻触开关 TACTILE SWITCH	
							型号/MODEL: TSD025*****	
标记 SING	处数 FREQUENCY	更改文件号 REVISION	签名 APPROVED	日期 DATE	比例 SCALE	1:1	一般公差 GENERAL TOLERANCE	
设计 DESIGN	朱元隆		2021.06.01	单位 UNIT	mm	$\geq 0-2 <$	$\pm 0.10$	<b>BZCN</b> 浙江博众电气有限公司 ZHEJIANG BOZHONG ELECTRONIC CO.,LTD.
审核 CHECKED	赵晓峰		2021.06.01	重量 WEIGHT		$\geq 2-5 <$	$\pm 0.25$	
批准 APPROVED	陈乐峰		2021.06.01			$\geq 5$	$\pm 0.30$	
							角度 ANGLE	$\pm 0.5^\circ$