



# BCT3299

## 16 channel 256 level brightness LED Drivers

### BCT3299

#### 16 channel 256 level brightness LED Drivers

#### GENERAL DESCRIPTION

The BCT3299 is a LED driver with independent 16 output channels, and the output current of each channel can be programmed to achieve 256 level, with maximum up to 30 mA.

The device is equipped with an internal program memory, which allows the operation without processor control. Each channel is independently programmed to on, off, gradually light up or down over time. In audio mode, the brightness of each channel can be proportional to the strength of the audio signal, also there will be the PWM output which sync to the audio signal. BCT3299 is designed to produce versatile lighting effects for portable devices.

Less than 2uA chip off current effective extend battery usage time, BCT3299 is lead-free environmental protection products, and the temperature range is -40 °C to + 85 °C. It has QFN-24 (4 x 4 mm) package, with the thickness of 0.75 mm.

#### FEATURES

- 16 channel constant current drive, each channel maximum output current of 30mA and maximum output current can be set by external Rext
- Each channel has 256 level, programmed by SPI interface.
- Built-In POR(Power On reset) function
- Co-Anode LED level connection
- Four frequency PWM output can be chosen from
- 2.7V-5.5V power supply range wide
- QFN-24 (4 mm x 4 mm) package

#### APPLICATIONS

- Mobile phone
- MP3/MP4/CD/Media Players
- Toys
- Feature home appliance

#### ORDERING INFORMATION

Order Number	Package Type	Temperature Range	Marking	QTY/Reel
BCT3299EGG-TR	QFN-24(4x4mm)	-40°C to +85°C	3299	3000

### Typical Operating Circuit

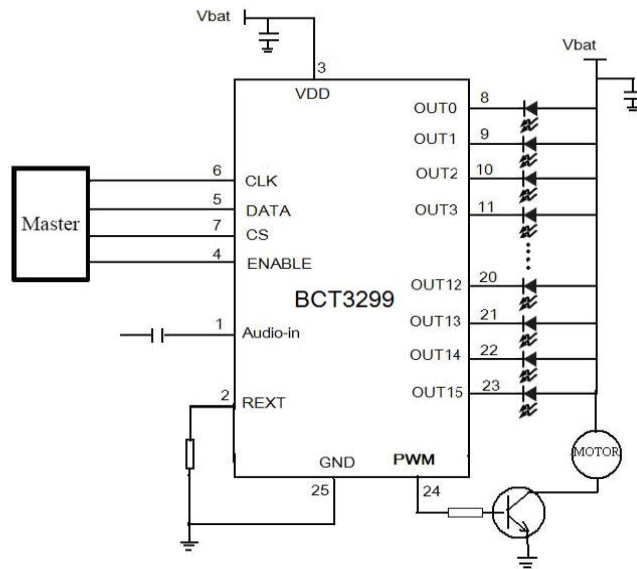

### ABSOLUTE MAXIMUM RATINGS

Supply Voltage, $V_{DD}$ .....	-0.3V to +5.5V
Voltage at any input Pin $V_I$ .....	-0.3V to $V_{DD}+0.3V$
Outx Current, $I_O$ .....	40mA
Package Thermal Resistance	
QFN4x4-24, $\theta_{JA}$ .....	32°C/W
Storage Temperature Range.....	-55°C to +150°C
Junction Temperature.....	150°C
Operating Temperature Range.....	-40°C to +85°C
Lead Temperature (Soldering, 10 sec).....	260°C
ESD Susceptibility	
HBM.....	2000V
MM.....	200V

**NOTE:**

Stresses beyond those listed under “Absolute Maximum Ratings” may cause permanent damage to the device. These are stress ratings only, and functional operation of the device at these or any other conditions beyond those indicated in the operational sections of the specifications

is not implied. Exposure to absolute maximum rating conditions for extended periods may affect device reliability.

### CAUTION

This integrated circuit can be damaged by ESD if you don't pay attention to ESD protection. Broadchip recommends that all integrated circuits be handled with appropriate precautions. Failure to observe proper handling and installation procedures can cause damage. ESD damage can range from subtle performance degradation to complete device failure. Precision integrated circuits may be more susceptible to damage because very small parametric changes could cause the device not to meet its published specifications.

Broadchip reserves the right to make any change in circuit design, specification or other related things if necessary without notice at any time. Please contact Broadchip sales office to get the latest datasheet.

### PIN CONFIGURATION (TOP VIEW)

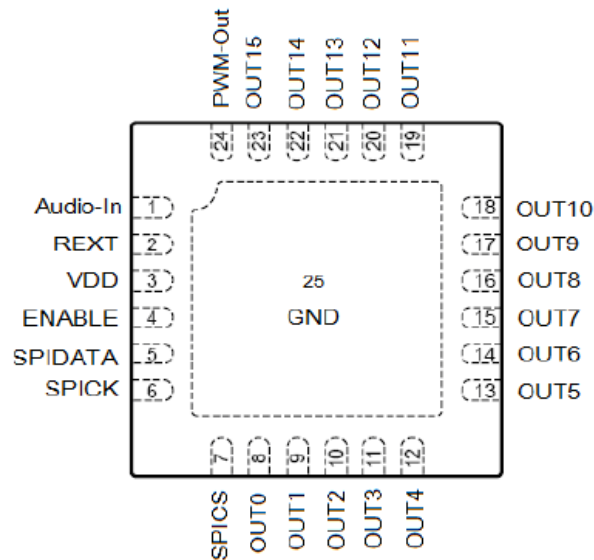

### PIN DESCRIPTION

PIN	NAME	FUNCTION
1	Audio-In	Audio input.
2	REXT	Current reference, set maximum current for all channels.
3	VDD	Power supply.
4	ENABLE	System enable.
5	SPIDATA	SPI DATA.
6	SPICK	SPI CLK.
7	SPICS	SPI CS.
8 to 23	OUT0 to OUT15	LED drive Channels.
24	PWM	Audio PWM or Level output.
25	GND	Ground.



# BCT3299

## 16 channel 256 level brightness LED Drivers

### ELECTRICAL CHARACTERISTICS

( $V_{DD}$ = 2.7V-5.5V,  $T_A$  = 25°C, unless otherwise specified.)

PARAMETER	SYM	CONDITIONS	MIN	TYP	MAX	UNITS
Supply Voltage Range	$V_{DD}$		2.7		5.5	V
Quiescent Current	$I_{VDD}$	$R_{EXT}=4K$ , OUT0-OUT15 open, $V_{DD}=5.5V$		1.6	2	mA
Shutdown Current	$I_{SHUT}$	Shutdown mode, $V_{DD}=5.5V$			2	uA
Output Current Accuracy	$I_O$	$R_{EXT}=4K\Omega$ , $V_{dropout}=1V$	18	20	22	mA
		$R_{EXT}=5K\Omega$ , $V_{dropout}=1V$	14.5	16	17.5	
Output current match		$R_{EXT}=4K\Omega$ , $V_{dropout}=1V, I_O=20mA$		$\pm 1$	$\pm 3$	%
Dropout Voltage	$V_{drop}$	$V_{DD}=3.3V, I_O=20mA$		300	500	mV
Logic "H" input Voltage	$V_{IH}$		1.4			V
Logic "L" input Voltage	$V_{IL}$				1	V

### TYPICAL APPLICATION

#### Serial (SPI) interface

Serial (SPI) interface is for receiving the control signals sent from controller, then decode the received command and send it to the corresponding register and control module. It has three pin: CS, SCLK and DIN.

Pin Name	Attribute	Direction	Description
SPICK	Rising edge	MCU->BCT3299	Serial bus clock
SPIDATA	Level	MCU->BCT3299	Serial data
SPICS	Active Low	MCU->BCT3299	SPI bus chip selection

Serial (SPI) interface can only do write operation form MCU to BCT3299, it is not readable. The fixed data width is 16 bits.

Figure 2 shows the timing diagram of this serial interface. When no data transmit, SPICK is forced to LOW and SPICS is forced to HIGH. Once the data need to be send from controller to BCT3299, SPICS is pulled LOW to enable the transmission. At rising edge of the CLK, data is latched. SPICS keep LOW for the duration of the transmission. First 8 bits of DIN will be the register address and following 8 bits will be the data of the register.

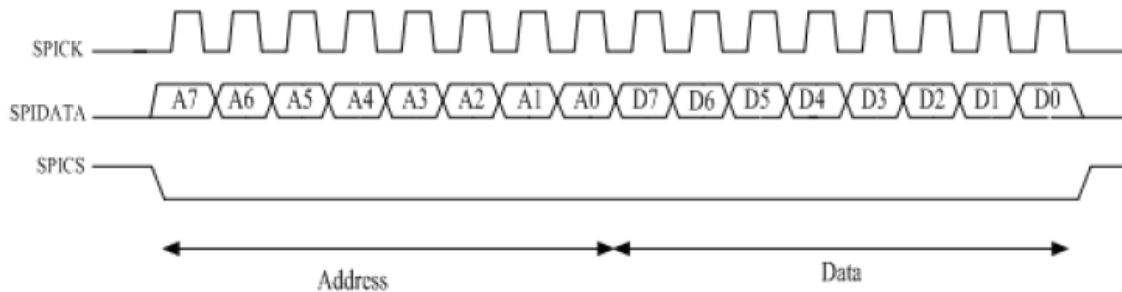

Figure 2: SPI timing

#### Serial Port Interface Timing

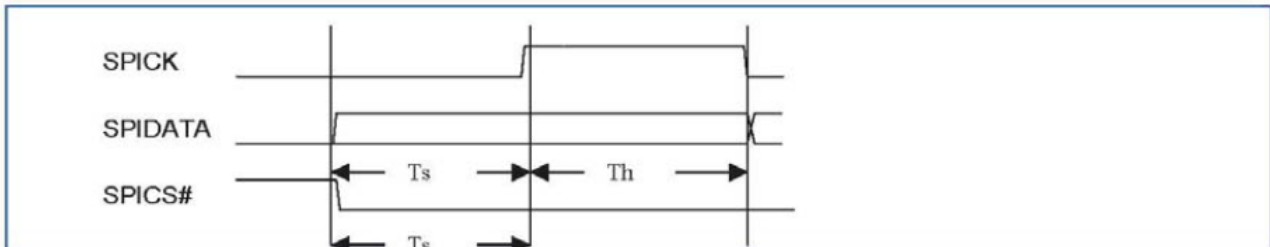

Figure 3. SPI Interface Timing Diagram

Symbol	Parameter	Min	Typ	Max	Unit
Ts	SPIDATA to SPICK setup time	4			ns
Th	SPIDATA to SPICK hold time	20			ns



# BCT3299

## 16 channel 256 level brightness LED Drivers

The maximum output current per row is set by a single external resistor REXT, which is between the REXT pin and GND pin. The maximum channel output current can be calculated as:

$$I_{O(max)} = 0.8 \times 200 / R_{ext} \text{ (mA)}$$

**The max output current REXT values**

REXT(KΩ)	IOmax(mA)
6	27
8	20
10	16

### Registers Definition

**00H**

**OUT0 Mode register**

	MSB		LSB
Bit	D7:D6	D5	D4:D0
Name	Mode[1:0]	Following Reverse	Phase Offset[4:0]
Default	00	0	00000

#### Mode [1:0]

- 00 Normal mode
- 01 Audio mode
- 10 Breathing mode
- 11 Follow mode

Normal mode

Brightness control register set the current of corresponding output channels for external LEDs

Audio mode

The current of corresponding output channels will proportional to the strength of audio input signal

Breath mode

Channel current will change gradually form 0 to maximum and from maximum to 0 according to register setting, Thus the brightness of LED will gradually light up or down over certain time period.

Follow mode

The channel will follow the specified channel behavior, which is indicated in the brightness register "Following Channel".

#### Following Reverse

In the following mode, if "Following Reverse" bit is 0, the channel can follow the output of the specified channel, if "Following Reverse" bit is 1, it will follow reverse the specified channel output.

#### Phase offset[4:0]

In breathing mode, it is for setting the starting brightness level. From light off to the full light up, there will be 32 levels, which can be set by these bits.

**01H**

**OUT0 Brightness**

	MSB		LSB					
Bit	D7	D6	D5	D4	D3	D2	D1	D0
Name	Normal mode Brightness[7:0]							



# BCT3299

## 16 channel 256 level brightness LED Drivers

	Breath mode	Breath Step[1:0]		Breath Speed[5:0]					
	Following mode	NC				Following Channel[3:0]			
Default		0	0	0	0	0	0	0	0

### Brightness[7:0]

In normal mode, the eight bits setting the brightness of the output channel.

- 00000000    0/256    Light down
- 00000001    2/256
- 00000010    3/256
- .....
- 11111111    256/256    the brightest

### Breath Step[1:0]

In the breathing mode, the 2 bits set the breathing levels.

- 00   256 levels
- 01   128 levels
- 10   64 levels
- 11   32 levels

### Breath Speed [5:0]

In the breathing mode, the 6 bits set the breathing cycle time:

$$T = 2 (n + 1) * m / 1250 \text{ (seconds)}$$

n is the Breath Speed [5:0], m is the Breath Step[1:0].

### Following Channel[3:0]

In the following mode, the four bits decided which channel it will follow.

Same settings for other OUT channels.

#### 02H, 03H

OUT1 channel setting, same with that of OUT0

#### 04H, 05H

OUT2 channel setting, same with that of OUT0

#### 06H, 07H

OUT3 channel setting, same with that of OUT0

#### 08H, 09H

OUT4 channel setting, same with that of OUT0

#### 0AH, 0BH

OUT5 channel setting, same with that of OUT0

#### 0CH, 0DH

OUT6 channel setting, same with that of OUT0

#### 0EH, 0FH



# BCT3299

## 16 channel 256 level brightness LED Drivers

OUT7 channel setting, same with that of OUT0

**10H, 11H**

OUT8 channel setting, same with that of OUT0

**12H, 13H**

OUT9 channel setting, same with that of OUT0

**14H, 15H**

OUT10 channel setting, same with that of OUT0

**16H, 17H**

OUT11 channel setting, same with that of OUT0

**18H, 19H**

OUT12 channel setting, same with that of OUT0

**1AH, 1BH**

OUT13 channel setting, same with that of OUT0

**1CH, 1DH**

OUT14 channel setting, same with that of OUT0

**1EH, 1FH**

OUT15 channel setting, same with that of OUT0

### 20H

#### AGC control register

Bit	MSB			LSB
	D7	D6:D4	D3	D2:D0
Name	AGC enable	Gain adjust[2:0]	Shutdown	PWM mode
Default	0	000	1	000

#### AGC enable

Audio input automatic gain control enable

0 Disable AGC and audio gain is set by "gain adjust[2:0]"

1 Enable AGC(automatic gain control )

#### Gain adjust[2:0]

Audio gain

000 0db 100 +12db

001 +3db 101 +15db

010 +6db 110 +18db

011 +9db 111 -6db

#### Shutdown

When 1, all registers, except this one, will be reset, chip will be in shut down mode. If the chip need to leave the shut down mode, this bit should be reset to 0.

#### PWM mode [2-0]

The three bits Set type of signal output from PWM out pin. There is two type of output signal, one is level





# BCT3299

## 16 channel 256 level brightness LED Drivers

---

output and another is PWM output.

Level output means the pin will be high when input audio signal amplitude is higher than threshold, otherwise it will be low. There are three threshold levels for setting the sensitivity. PWM output, means the pin will output PWM signals and the duty ratio of the PWM will follow the input audio signal, which is pre-processed by built-in audio filter. Also, the frequency of output PWM has four options to choose from.

- 000 PWM out output disable, the pin output is 0.
- 001 level mode output, high sensitivity.
- 010 level mode output, normal sensitivity.
- 011 level mode output, low sensitivity.
- 100 PWM mode output, PWM frequency of 150 Hz.
- 101 PWM mode output, PWM frequency of 300 Hz.
- 110 PWM mode output, PWM frequency of 600 Hz.
- 111 PWM mode output, PWM frequency of 1200 Hz.

**PACKAGE OUTLINE DIMENSIONS**

**QFN-4x4-24L**

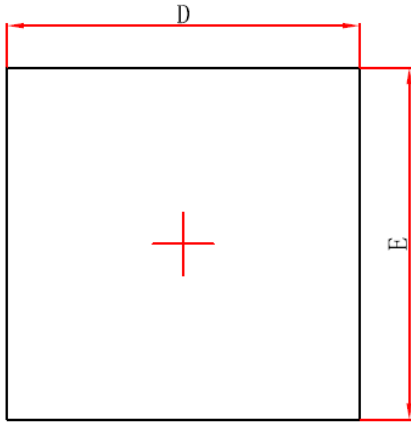

TOP VIEW

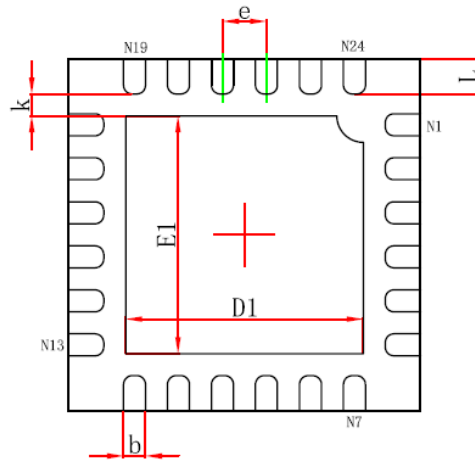

BOTTOM VIEW

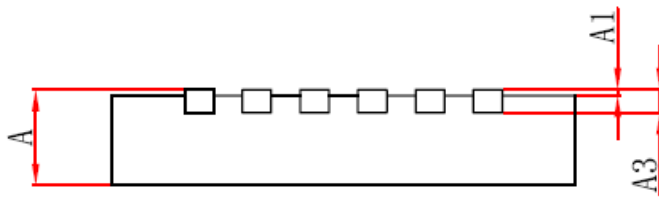

SIDE VIEW



**BCT3299**  
**16 channel 256 level brightness**  
**LED Drivers**

---

Symbol	Dimensions In Millimeters		Dimensions In Inches	
	Min.	Max.	Min.	Max.
A	0.700/0.800	0.800/0.900	0.028/0.031	0.031/0.035
A1	0.000	0.050	0.000	0.002
A3	0.203REF.		0.008REF.	
D	3.924	4.076	0.154	0.160
E	3.924	4.076	0.154	0.160
D1	2.600	2.800	0.102	0.110
E1	2.600	2.800	0.102	0.110
k	0.200MIN.		0.008MIN.	
b	0.200	0.300	0.008	0.012
e	0.500TYP.		0.020TYP.	
L	0.324	0.476	0.013	0.019