



CJ809 Series

■ INTRODUCTION

The CJ809 Series is a series of high-precision voltage detectors with a built-in delay time generator of fixed time, developed using CMOS process.

The detection voltage is fixed internally, with an accuracy of $\pm 2.0\%$. Internal oscillator and counter timer can delay the release signal without external parts, delay times 200 ms Two output forms, NMOS open-drain and CMOS output are available.

■ APPLICATIONS

- Memory battery back-up circuits
- Power-on reset circuits
- Power failure detection
- Power monitor for portable equipment such as notebook computers, digital cameras, PDA, and cellular phones.
- Constant voltage power monitors for cameras, video equipment and communication devices.
- Power monitor for microcomputers and reset for CPUs.

■ FEATURES

- Ultra-low current consumption:
0.9 μ A@3.5V(Typ.)
- High-precision detection voltage: $\pm 2.0\%$
- Hysteresis characteristics: $-V_{DET} \times 5\%$ (Typ.)
- Operating voltage range: 0.95V to 7.0V
- Detection voltage: 1.5V to 6.0V (10mV step)
- Delay time: 210 ms (Typ.)
- Output forms:
NMOS open-drain output (Active Low)
CMOS output (Active Low)

■ ORDER INFORMATION

CJ809 ①②③④⑤

DESIGNATOR	SYMBOL	DESCRIPTION
①	C	CMOS
	N	NMOS open drain
②③④	Integer	Detection Voltage “④”elide when it is “0” e.g. 3.0V=②:3, ③:0 2.93V=②:2, ③:9, ④:3
⑤	M	Package: SOT-23-3L
	P	Package: SOT-89-3L
	N	Package: SOT-23

■ BLOCK DIAGRAMS

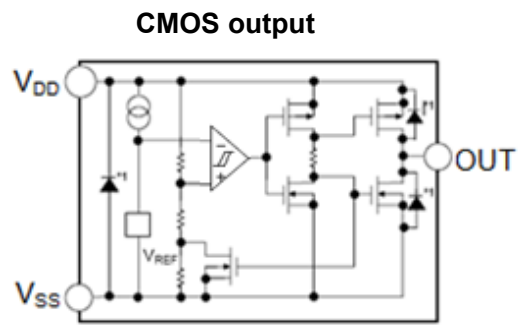
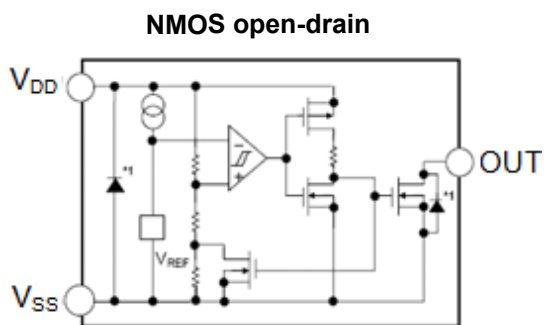

■ PIN CONFIGURATION

SOT-23
SOT-23-3L

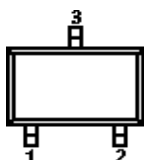

PIN NO.	N/M	FUNCTION
1	V_{SS}	Ground
2	V_{OUT}	Voltage detection output pin
3	V_{DD}	Voltage input pin

SOT-89-3L

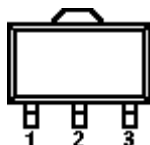

PIN NO.	P	FUNCTION
1	V_{OUT}	Voltage detection output pin
2	V_{DD}	Voltage input pin
3	V_{SS}	Ground

Electrical Characteristics

■ ABSOLUTE MAXIMUM RATINGS

(Ta=25°C, unless otherwise specified)

PARAMETER		SYMBOL	RATINGS	UNITS
Power supply voltage		V _{DD}	V _{SS} -0.3 ~ V _{SS} +8	V
Output voltage		V _{OUT}	V _{SS} -0.3 ~ V _{SS} +8	V
Power dissipation	SOT-23-3L	PD	250	mW
	SOT-89-3L		600	
	SOT-23		200	
Operating ambient temperature		T _{opr}	-40 ~ +85	°C
Storage temperature		T _{stg}	-40 ~ +125	°C
Soldering Temperature & Time		T _{solder}	260°C, 10s	

■ ELECTRICAL CHARACTERISTICS

(Ta=25°C, unless otherwise specified)

PARAMETER	SYMBOL	CONDITIONS		MIN	TYP	MAX	UNITS
Detection voltage*1	-V _{DET}	—		-V _{DET(S)} ×0.98	-V _{DET(S)}	-V _{DET(S)} ×1.02	V
Hysteresis width	V _{HYS}	—		0.02× -V _{DET(S)}	0.05× -V _{DET(S)}	0.08× -V _{DET(S)}	V
Current consumption	I _{SS}	V _{DD} = -V _{DET} +0.5V	C/N20~26	—	1.0	3.0	uA
			C/N 26~39	—	1.2	3.2	uA
			C/N 39~60	—	1.5	3.5	uA
Operating voltage	V _{DD}	—		0.95	—	7	V
Output current	I _{OUT}	NMOS: V _{OUT} =0.5 V V _{DD} =-V _{DET} +0.5V	C/N 20~26	3.0	13.0	—	mA
			C/N 26~39	3.0	15.0	—	mA
			C/N 39~60	3.0	18.0	—	mA
		PMOS: V _{DD} -V _{OUT} =0.5 V V _{DD} =-V _{DET} -0.5 V	C/N 20~26	1.5	4.0	—	mA
			C/N 26~39	1.5	6.0	—	mA
			C/N 39~60	1.5	8.0	—	mA
Leakage current	I _{LEAK}	Only for NMOS open-drain output products, V _{DD} =6.0 V, V _{OUT} =6.0 V			—	1.0	uA
temperature coefficient		Ta=-40°C ~+85°C		—	±120	±360	ppm/°C
Delay time	T _{PLH}			130	210	290	ms

*1. -V_{DET}: Actual detection voltage value, -V_{DET(S)}: Specified detection voltage value

■ TYPICAL APPLICATION CIRCUITS

1、CMOS output:

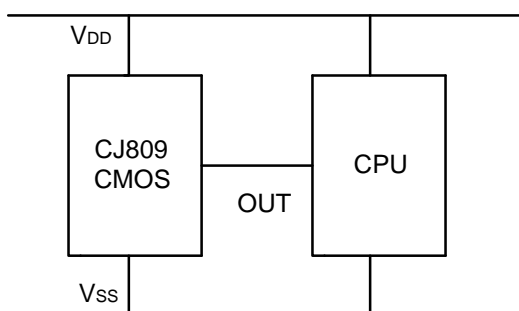

2、NMOS open-drain

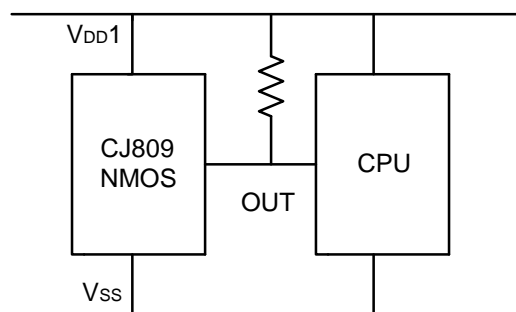
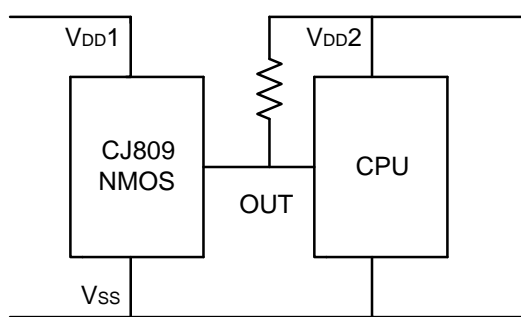

3. Forbidden Circuits

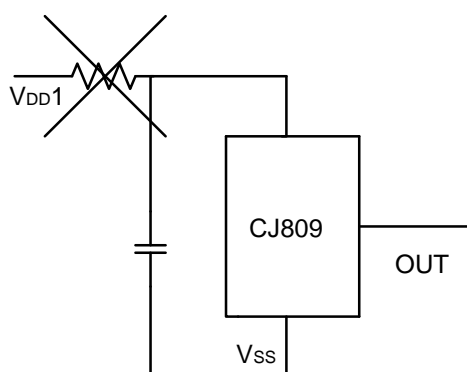

SOT-23 Package Outline Dimensions

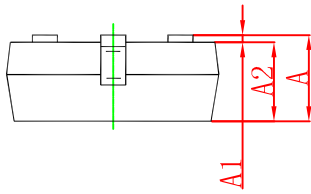
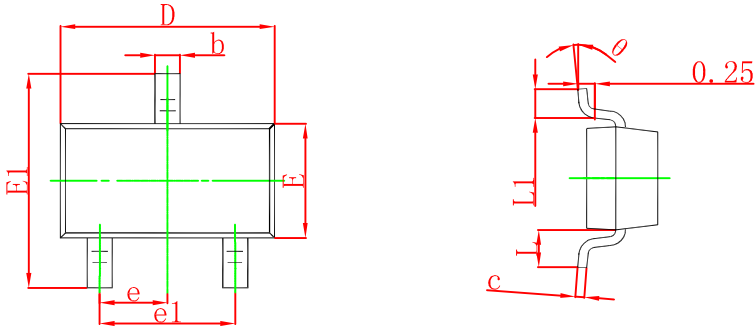

Symbol	Dimensions In Millimeters		Dimensions In Inches	
	Min.	Max.	Min.	Max.
A	0.900	1.150	0.035	0.045
A1	0.000	0.100	0.000	0.004
A2	0.900	1.050	0.035	0.041
b	0.300	0.500	0.012	0.020
c	0.080	0.150	0.003	0.006
D	2.800	3.000	0.110	0.118
E	1.200	1.400	0.047	0.055
E1	2.250	2.550	0.089	0.100
e	0.950 TYP.		0.037 TYP.	
e1	1.800	2.000	0.071	0.079
L	0.550 REF.		0.022 REF.	
L1	0.300	0.500	0.012	0.020
θ	0°	8°	0°	8°

SOT-23 Suggested Pad Layout

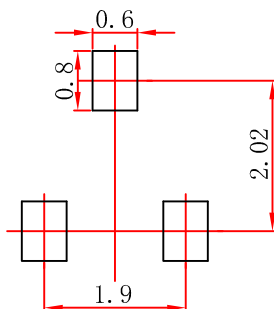

Note:

1. Controlling dimension: in millimeters.
2. General tolerance: ± 0.05 mm.
3. The pad layout is for reference purposes only.

SOT-23-3L Package Outline Dimensions

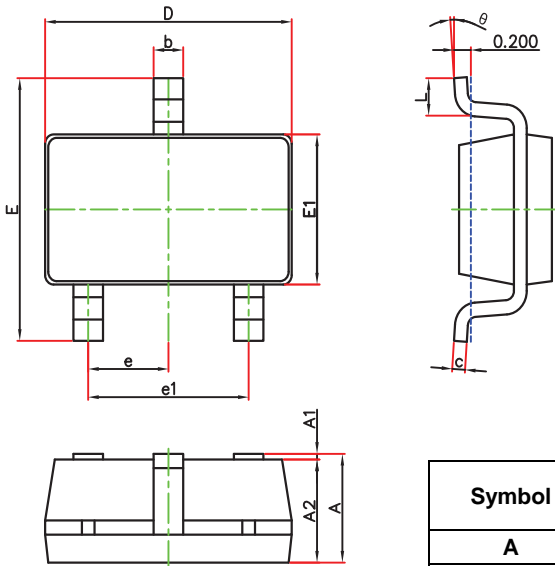

Symbol	Dimensions In Millimeters		Dimensions In Inches	
	Min.	Max.	Min.	Max.
A	1.050	1.250	0.041	0.049
A1	0.000	0.100	0.000	0.004
A2	1.050	1.150	0.041	0.045
b	0.300	0.500	0.012	0.020
c	0.100	0.200	0.004	0.008
D	2.820	3.020	0.111	0.119
E	2.650	2.950	0.104	0.116
E1	1.500	1.700	0.059	0.067
e	0.950(BSC)		0.037(BSC)	
e1	1.800	2.000	0.071	0.079
L	0.300	0.600	0.012	0.024
θ	0°	8°	0°	8°

SOT-23-3L Suggested Pad Layout

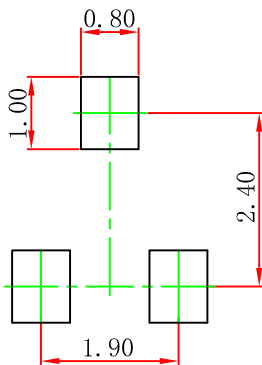

Note:

1. Controlling dimension: in millimeters.
2. General tolerance: $\pm 0.05\text{mm}$.
3. The pad layout is for reference purposes only.

SOT-89-3L Package Outline Dimensions

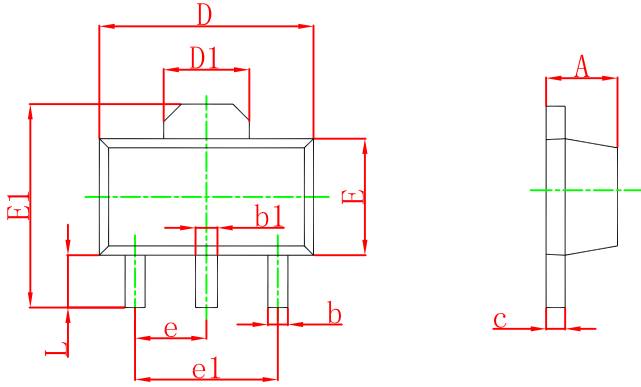

Symbol	Dimensions In Millimeters		Dimensions In Inches	
	Min.	Max.	Min.	Max.
A	1.400	1.600	0.055	0.063
b	0.320	0.520	0.013	0.197
b1	0.400	0.580	0.016	0.023
c	0.350	0.440	0.014	0.017
D	4.400	4.600	0.173	0.181
D1	1.550 REF		0.061 REF	
E	2.300	2.600	0.091	0.102
E1	3.940	4.250	0.155	0.167
e	1.500 TYP		0.060 TYP	
e1	3.000 TYP		0.118 TYP	
L	0.900	1.200	0.035	0.047

SOT-89-3L Suggested Pad Layout

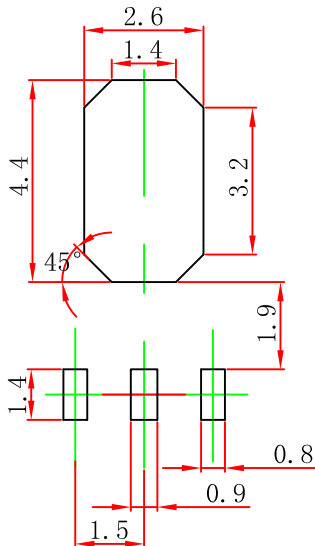

- Note:
1. Controlling dimension: in millimeters.
 2. General tolerance: ± 0.05 mm.
 3. The pad layout is for reference purposes only.

NOTICE

JSCJ reserves the right to make modifications, enhancements, improvements, corrections or other changes without further notice to any product herein. JSCJ does not assume any liability arising out of the application or use of any product described herein.