

N-Channel Enhancement-Mode MOSFET (30V, 10A)

PRODUCT SUMMARY

V_{DSS}	I_D	$R_{DS(on)}$ (m Ω) Max
30V	10A	15 @ $V_{GS} = 10V, I_D=10A$
		24 @ $V_{GS} = 4.5V, I_D=5A$

Features

- Advanced Trench Process Technology
- High Density Cell Design for Ultra Low On-Resistance
- Lead free product is acquired
- Surface mount Package
- Ordering information: GS4410 (Lead (Pb) - free and halogen - free)



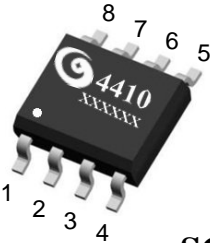

Pin 1 / 2 / 3: Source
Pin 4: Gate
Pin 5 / 6 / 7 / 8: Drain

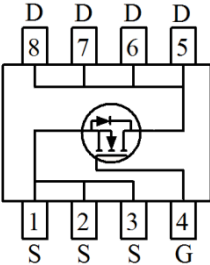

SOP-8

Absolute Maximum Ratings ($T_A=25^\circ\text{C}$, unless otherwise noted)

Symbol	Parameter	Ratings	Units
V_{DS}	Drain-Source Voltage	30	V
V_{GS}	Gate-Source Voltage	± 20	V
I_D	Drain Current @ $T_A=25^\circ\text{C}$	10	A
I_{DM}	Drain Current (Pulsed) ^b	50	A
I_S	Maximum Diode Forward Current ^a	4.2	A
E_{AS}	Avalanche Energy, Single Pulse ($L=0.5\text{mH}$) ^c	20	mJ
P_D	Total Power Dissipation @ $T_A=25^\circ\text{C}$ ^a	2	W
T_j, T_{stg}	Operating Junction and Storage Temperature Range ^a	-55 to +150	$^\circ\text{C}$
$R_{\theta JA}$	Thermal Resistance Junction to Ambient ^a	62.5	$^\circ\text{C/W}$

Note: a: Surface Mounted on FR4 Board, $t \leq 5\text{sec}$.

b: Pulse width limited by maximum junction temperature.

c: UIS tested and pulse width limited by maximum junction temperature 150 $^\circ\text{C}$ (initial temperature $T_j=25^\circ\text{C}$).

Electrical Characteristics (T_A=25°C, unless otherwise noted)

Symbol	Characteristic	Test Conditions	Min.	Typ.	Max.	Unit
• Off Characteristics						
BV _{DSS}	Drain-Source Breakdown Voltage	V _{GS} =0V, I _D =250μA	30	-	-	V
I _{DSS}	Zero Gate Voltage Drain Current	V _{DS} =24V, V _{GS} =0V	-	-	1	μA
I _{GSS}	Gate-Body Leakage Current	V _{GS} =±16V, V _{DS} =0V	-	-	±100	nA
• On Characteristics ^c						
V _{GS(th)}	Gate Threshold Voltage	V _{DS} =V _{GS} , I _D =250μA	1	-	3	V
R _{DS(on)}	Drain-Source On-State Resistance	V _{GS} =10V, I _D =10A	-	12	15	mΩ
		V _{GS} =4.5V, I _D =5A	-	15	24	
g _{FS}	Forward Trans conductance	V _{DS} =10V, I _D =9A	-	9	-	S
• Dynamic Characteristics ^d						
C _{iss}	Input Capacitance	V _{DS} =25V, V _{GS} =0V, f=1MHz	-	710	-	pF
C _{oss}	Output Capacitance					
C _{rss}	Reverse Transfer Capacitance					
R _g	Gate resistance	V _{DS} =0V, V _{GS} =0V, f=1MHz	1	2	3	Ω
• Switching Characteristics ^d						
Q _g	Total Gate Charge	V _{DS} =20V, I _D =9A, V _{GS} =4.5V	-	8	-	nC
Q _{gs}	Gate-Source Charge					
Q _{gd}	Gate-Drain Charge					
t _{d(on)}	Turn-on Delay Time	V _{GS} = 10V, V _{DS} = 15V, I _D =9A, R _L =15Ω, R _{GEN} =3.3Ω	-	7	-	nS
t _r	Turn-on Rise Time					
t _{d(off)}	Turn-off Delay Time					
t _f	Turn-off Fall Time					
t _{rr}	Body Diode Reverse Recovery Time	I _F =9A, dI/dt=100A/μS	-	24	-	nS
Q _{rr}	Body Diode Reverse Recovery Charge	I _F =9A, dI/dt=100A/μS	-	14	-	nC
• Drain-Source Diode Characteristics						
V _{SD}	Drain-Source Diode Forward Voltage	V _{GS} =0V, I _S =2.1A	-	-	1.2	V

Note: c: Pulse Test : Pulse Width < 300μs, Duty Cycle < 2%

d: Guaranteed by design, not subject to production testing.

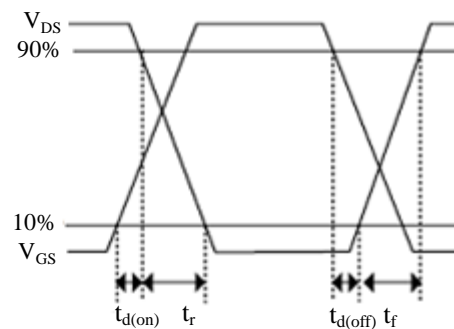
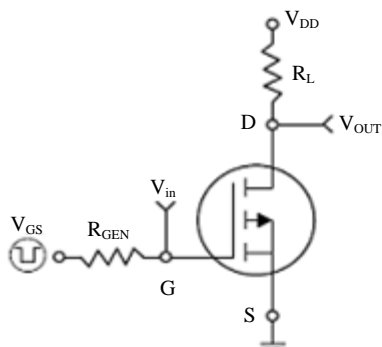

Switching Test Circuit and Switching Waveforms

Characteristics Curve

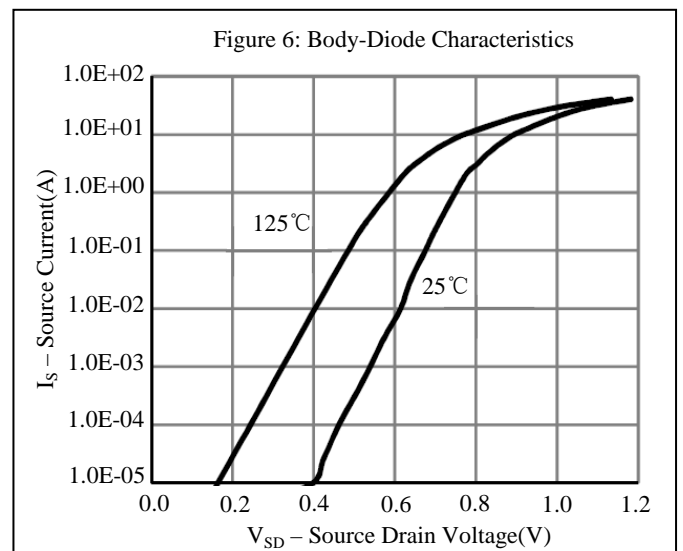
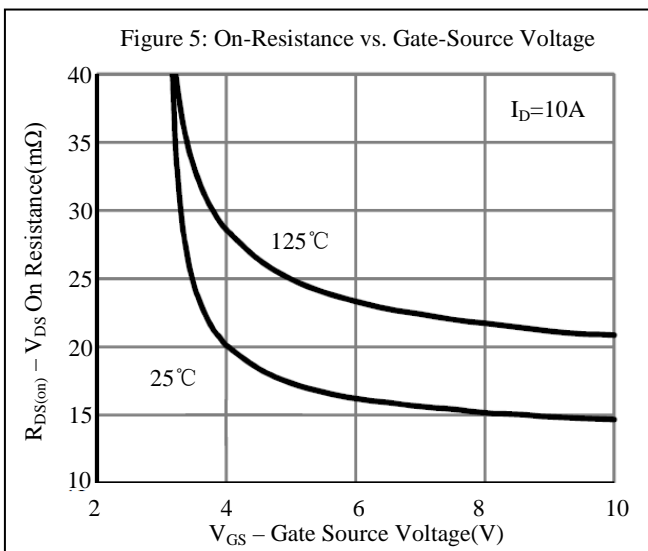
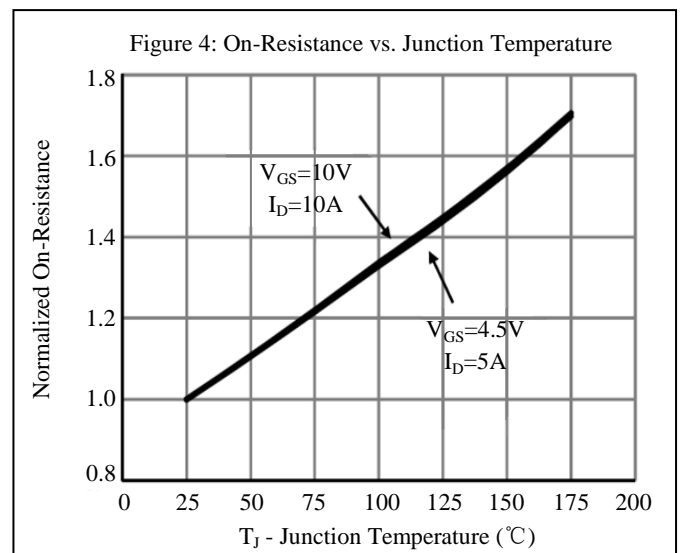
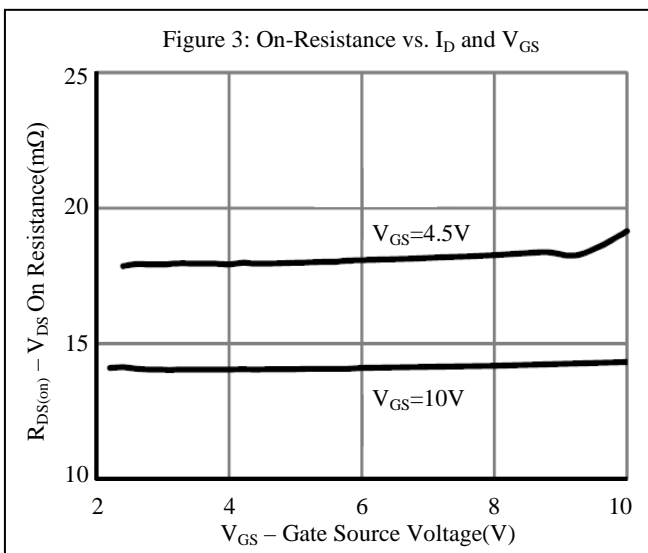
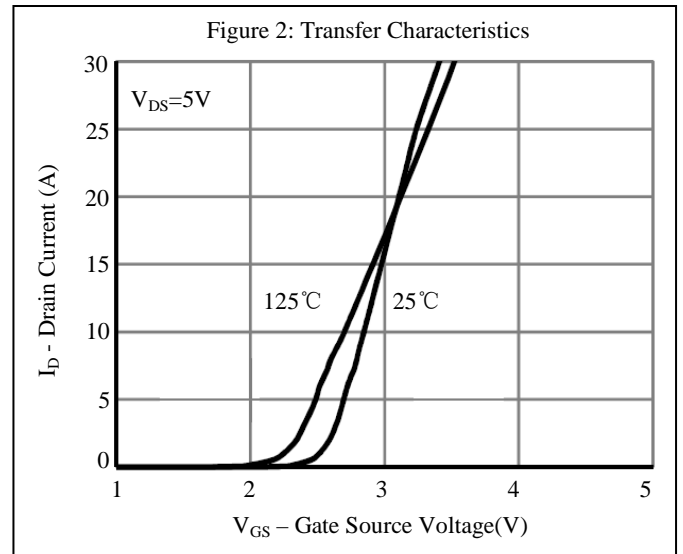
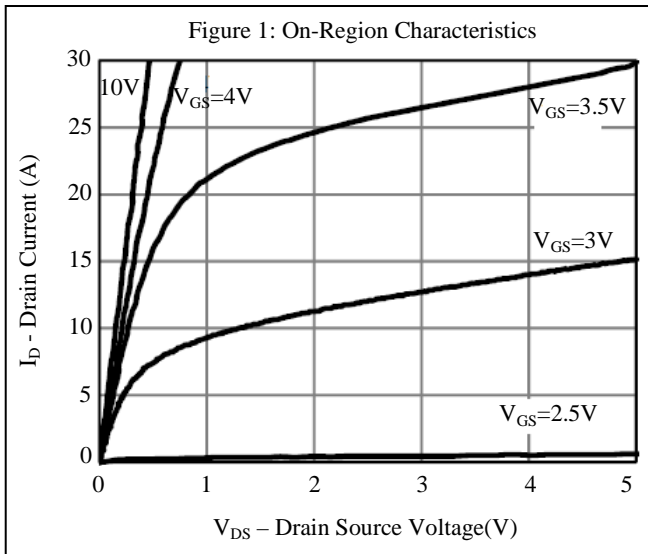

Characteristics Curve

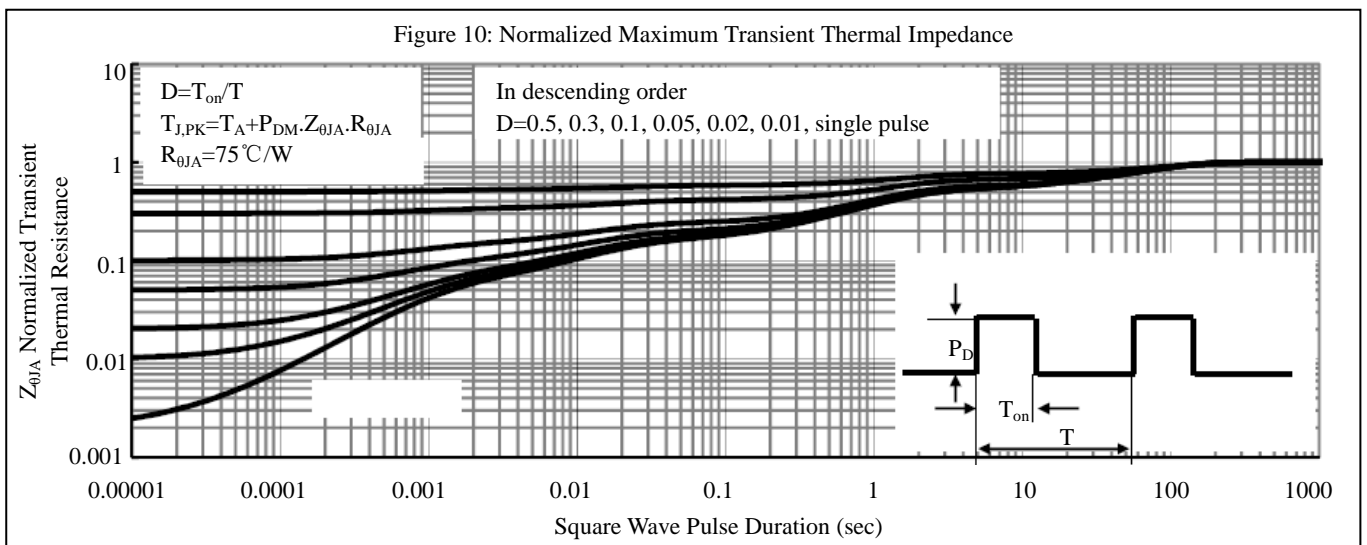
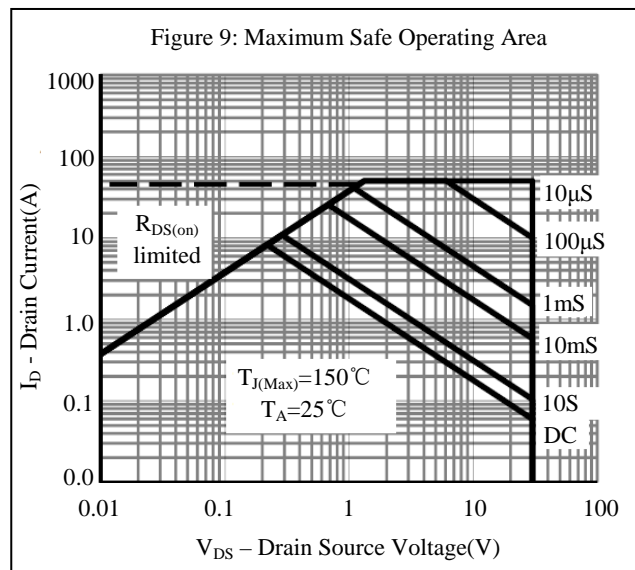
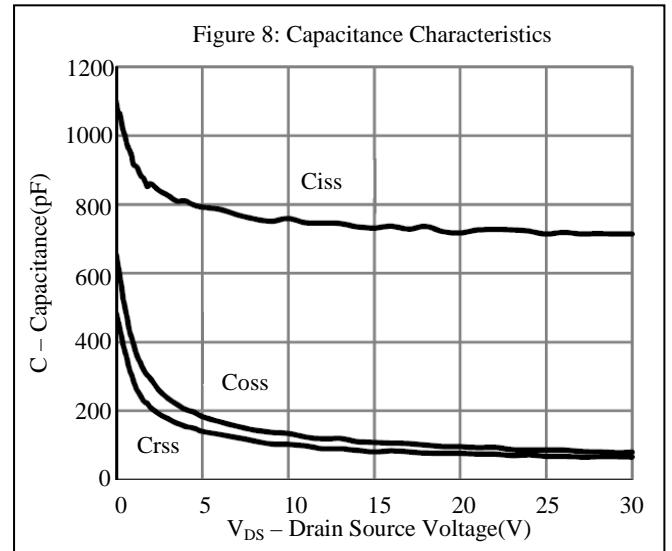
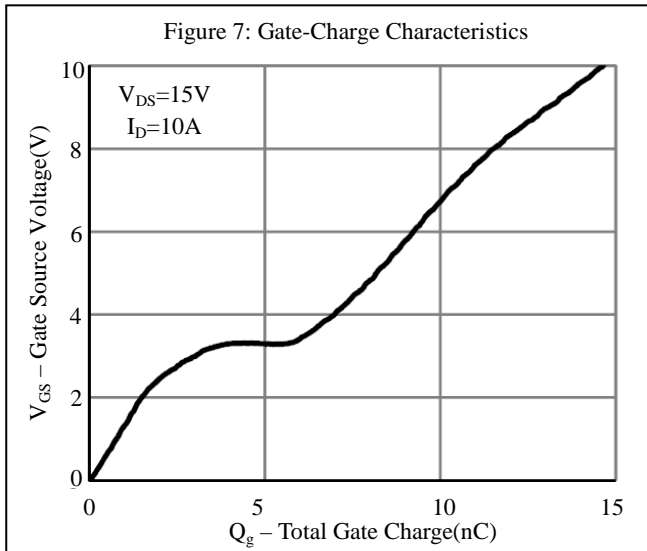

SOP-8 PACKAGE OUTLINE DIMENSIONS

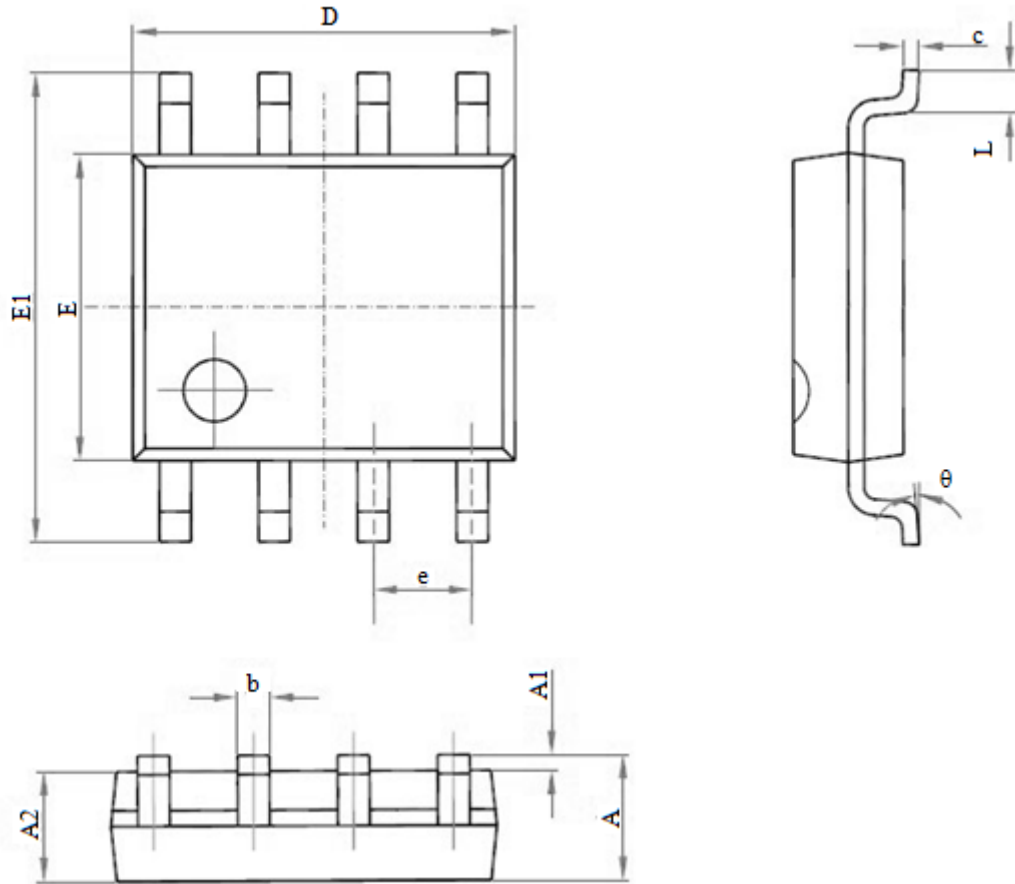

Symbol	Dimensions In Millimeters (MM)		Dimensions In Inches (MIL)	
	Min	Max	Min	Max
A	1.350	1.750	0.053	0.069
A1	0.100	0.250	0.004	0.010
A2	1.350	1.550	0.053	0.061
b	0.310	0.510	0.013	0.020
c	0.170	0.250	0.006	0.010
D	4.700	5.100	0.185	0.200
E	3.800	4.000	0.150	0.157
E1	5.800	6.200	0.228	0.244
e	1.270(BSC)		0.050(BSC)	
L	0.400	1.270	0.016	0.050
theta	0°	8°	0°	8°



Notice

1. Specification of the products displayed herein is subject to change without notice. Continuous development may necessitate changes in technical data without notice. GEMMICRO or anyone on its behalf assumes no responsibility or liability for any errors or inaccuracies.

2. Stresses beyond those listed under “Absolute Maximum Ratings” may cause permanent damage to the device. These are stress ratings only and functional operation of the device at these or any other conditions beyond those indicated in the operational sections of the specifications are not implied. Exposure to absolute maximum rating conditions for extended periods may affect device reliability.