

General Description

The GC5019 IC is best created for single-cell lithium-ion/lithium polymer rechargeable battery protection and it also comprises high-accuracy voltage detectors and delay circuits. This IC is suitable for protecting single-cell rechargeable lithium-ion/lithium polymer battery packs against the problems of overcharge, overdischarge and overcurrent.

Features

The features that GC5019 comprised is as follows:

- Overcharge detection voltage 4.375V Accuracy: $\pm 25\text{mV}$
- Overcharge release voltage 4.175V Accuracy: $\pm 50\text{mV}$
- Overdischarge detection voltage 2.50V Accuracy: $\pm 75\text{mV}$
- Overdischarge release voltage 2.90V Accuracy: $\pm 75\text{mV}$
- Discharge overcurrent detection voltage 150mV Accuracy: $\pm 20\text{mV}$
- Short-circuiting detection voltage 1.36V Accuracy: $\pm 350\text{ mV}$
- Charger detection voltage 1.2V
- Delay times are generated by an internal circuit (external capacitors are unnecessary).
- Low Quiescent current consumption @ 6.0 μA for GC5019 (Typ, $V_{\text{DD}}=3.9\text{V}$)
- Low power down standby current consumption @ 1.0 μA for GC5019 (Max, $V_{\text{DD}}=2.0\text{V}$)
- 0V battery charging function available
- High voltage device is used for charger connection in OC and CS
- Wide operating temperature range -40°C to $+85^{\circ}\text{C}$
- Small package SOT-23-6L
- Ordering information: GC5019 -G(Lead(Pb)-free and halogen-free)

Applications

- lithium-ion rechargeable battery packs
- lithium polymer rechargeable battery packs

Product Ordering Information

Model	Over-charge Detection Voltage V	Over-charge Release Voltage V	Over-discharge Voltage V	Over-discharge Release Voltage V	Discharge Over-current Voltage V	0V Charge function	Auto Recovery
GC5019	4.375 \pm 0.025V	4.175 \pm 0.05V	2.50 \pm 0.075 V	2.90V \pm 0.075 V	0.15 \pm 0.03V	YES	YES

Block Diagram

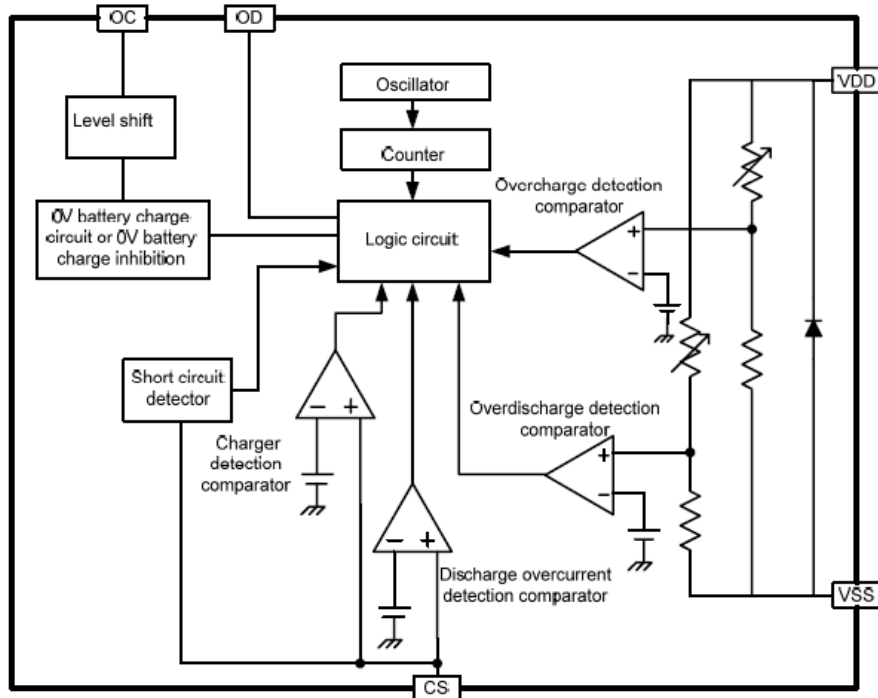

Pin Configuration and Package Information

Pin	Symbol	Description	Package
1	OD	MOSFET gate control pin for discharge	 SOT-23-6L
2	CS	Input pin for current sense Charger control	
3	OC	MOSFET gate control pin for charge	
4	NC		
5	V _{DD}	Positive power input pin	
6	V _{SS}	Negative power input pin	



Absolute Maximum Ratings (V_{SS}=0V, T_A=25°C unless otherwise specified)

Item	Symbol	Rating	Unit
Input voltage between V _{DD} and V _{SS} pin	V _{DD}	1.5 to 10	V
OC output pin voltage	V _{OC}	V _{DD} -0.5 to V _{DD} +0.4	V
OD output pin voltage	V _{OD}	V _{SS} -0.5 to V _{DD} +0.4	V
CS input pin voltage	V _{CS}	V _{DD} -25 to V _{DD} +0.3	V
Operating Temperature Range	T _{OP}	-40 to +85	°C
Storage Temperature Range	T _{ST}	-55 to +125	°C
Power dissipation	P _D	150	mW

Electrical Characteristics (V_{SS}=0V, T_A=25°C unless otherwise specified)

Item	Symbol	Condition	Min.	Typ.	Max.	Unit
Operating input voltage	V _{DD}	-	1.5	-	10	V
Operating voltage between OC & CS	-	-	1.5	-	25	V
Minimum operating voltage for 0V Charging	V _{st}	V _{DD} =V _{CS} , V _{DD} -V _{SS} =0V	1.2	-	-	V
Discharging overcurrent release resistance	R _{short}	V _{DD} =3.6V, CS=1.0V	15	30	45	KΩ
Current consumption	I _{DD}	V _{DD} =3.5V, CS=0V	-	3.0	6.0	μA
Overcharge detection voltage	V _{CU}	R1=100Ω	4.350	4.375	4.400	V
Overcharge Release Voltage	V _{CR}	R1=100Ω	4.125	4.175	4.225	V
Over-discharge Detection Voltage	V _{DL}	R1=100Ω	2.425	2.50	2.575	V
Over-discharge Release Voltage	V _{DR}	R1=100Ω	2.825	2.90	2.975	V
Discharge Overcurrent Detection Voltage	V _{DIP}	V _{DD} =3.6V, R1=1.0KΩ	130	150	170	mV
Short Circuit Detection Voltage	V _{SIP}	V _{DD} =3.0V	0.82	1.36	1.75	V
Charger Detection Voltage	V _{CHA}	V _{DD} =3.6V, R2=1.0k	0.27	-0.5	-0.86	V
Overcharge Delay Time	T _{OC}	V _{DD} =3.9V to 4.5V	75	110	150	ms
Overdischarge Delay Time	T _{OD}	V _{DD} =3.6V to 2.0V	40	55	70	ms
Discharge Overcurrent Delay Time	T _{DIP}	V _{DD} =3.6V	5	7	10	ms
Short Circuit Delay Time	T _{SIP}	V _{DD} =3.0V	40	80	120	μs
OD Pin Output "H" Voltage	V _{DH}	V _{DD} =3.6V, CS=0V, I _{OCH} =-10μA	V _{DD} -0.4	V _{DD} -0.2	-	V
D Pin Output "L" Voltage	V _{DL}	V _{DD} =2.0V, CS=0V, I _{ODL} =10μA	-	0.2	0.4	V
OC Pin Output "H" Voltage	V _{CH}	V _{DD} =3.6V, CS=0V, I _{OCH} =-10μA	V _{DD} -0.4	V _{DD} -0.2	-	V
OC Pin Output "L" Voltage	V _{CL}	V _{DD} =4.5V, CS=0V, I _{OCL} =10μA	-	0.2	0.4	V

Example of Battery Protection IC Connection

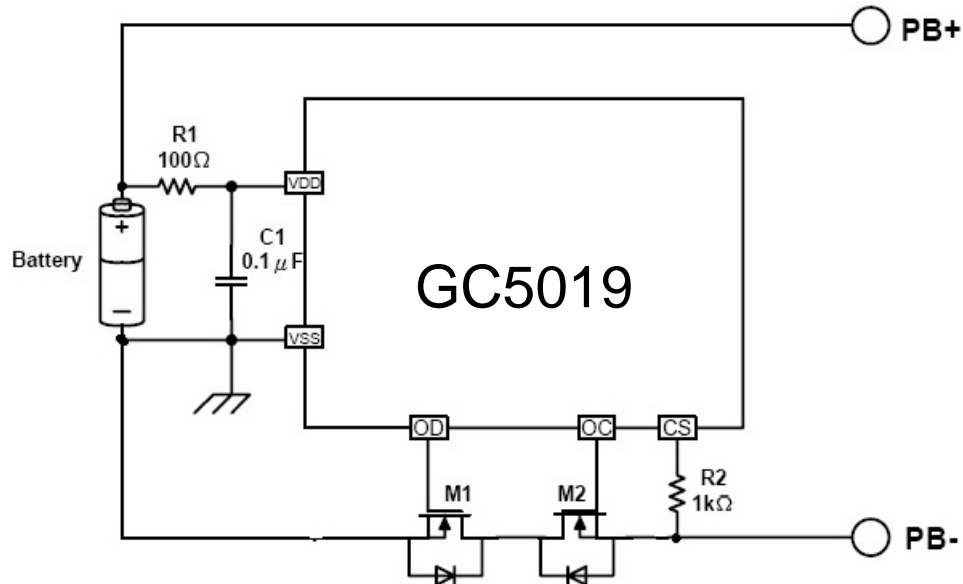

Symbol	Device Name	Purpose	Min.	Typ.	Max.	Remark
R1	Resistor	limit current, stabilize V_{DD} and strengthen ESD protection	100Ω	100Ω	470Ω	*1
R2	Resistor	limit current	500Ω	1.0 kΩ	1.3kΩ	*2
C1	Capacitor	stabilize V_{DD}	-	0.1μF	-	*3
M1	N-MOSFET	Discharge control	-	-	-	*4
M2	N-MOSFET	Charge control	-	-	-	*5

*1. R1 should be as small as possible to avoid lowering the overcharge detection accuracy due to current consumption. When a charger is connected in reversed, the current flows from the charger to the IC. At this time, if R1 is connected to high resistance, the voltage between V_{DD} pin and V_{SS} pin may exceed the absolute maximum rating.

*2. If R2 has a resistance higher than 2kΩ, the charging current may not be cut when abnormal over-current appeared during charging. Please select as large a resistance as possible to prevent current when a charger is connected in reversed.

*3. C1 will stabilize the supply voltage of V_{DD} , the value of C1 should be equal to or more than 0.01μF.

*4. If a FET with a threshold voltage equal to or higher than the overdischarge detection voltage is applied, discharging may be stopped before overdischarge is detected.

*5. If the withstanding voltage between the gate and source is lower than the charger voltage, the FET may be destroyed.

Description of Operation

1. Normal Status

This IC monitors the voltage of the battery connected between the V_{DD} pin and V_{SS} pin and the voltage difference between the CS pin and VSS pin to control charging and discharging.

When the battery voltage is in the range from overdischarge detection voltage (V_{DL}) to overcharge detection voltage (V_{CU}), and the CS pin voltage is in the range from the charger detection voltage (V_{CHA}) to discharge overcurrent detection voltage (V_{DIP}), the IC turns both the charging and discharging control MOSFET on. This condition is called the normal status. Under this condition, charging and discharging can both be carried out freely.

2. Over-charge Status

Under the normal status, as soon as the battery voltage becomes higher than the overcharge detection voltage (V_{CU}) during charging and the detection continues longer than the overcharge detection delay time (T_{OC}), the GC5019 will turn the charging control MOSFET off (OC pin) to stop charging. This condition is called the overcharge status.

The overcharge status can be released by the following two cases:

- (1) The voltage of the battery cell is equal to or lower than the overcharge release voltage (V_{CR}) due to self-discharge.
- (2) When load is connected and the battery voltage falls below the overcharge protection voltage (V_{CU}).

3. Over-discharge Status

When the battery voltage falls below than the overdischarge detection voltage (V_{DL}) during discharging in the normal status and the detection continues longer than the overdischarge detection delay time (T_{OD}), the GC5019 will turn the discharging control MOSFET off (OD pin) so as to stop discharging. This condition is called the overdischarge status.

When the MOSFET is off, CS pin voltage is pulled up by the resistor to V_{DD} in the IC, at this time, the power consumption is reduced to the lowest. This condition is called the "SLEEP MODE".

The overdischarge status will be released by two cases:

- (1) When CS pin voltage is equal to or lower than the charger detection voltage (V_{CHA}) by charging and the V_{DD} pin voltage is higher than overdischarge detection voltage (V_{DL}).
- (2) When CS pin voltage is equal to or higher than the charger detection voltage (V_{CHA}) by charging and the V_{DD} pin voltage is higher than overdischarge release voltage (V_{DR}).

4. Charger detection Status

When the charger is connected to the overdischarge battery, if the voltage of CS pin is lower than charger detection voltage (V_{CHA}), based on the charger detection function, as long as the battery voltage is higher than overdischarge voltage (V_{DL}), the discharge status will be released and discharging control MOSFET (OD pin) will be turned on. This process is called the "charger detection status". Conversely, if CS pin's voltage is not lower than charger detection voltage (V_{CHA}), the battery voltage has to reach the overdischarge release voltage (V_{DR}) to relieve the overdischarge status as usual.

5. Discharge Overcurrent Status (Discharge Overcurrent & Short Circuit)

Under normal condition, the GC5019 continuously monitors the discharge current by sensing the voltage of CS pin. If the voltage of CS pin exceeds the overcurrent detection voltage (V_{DIP}) and the condition lasts beyond the overcurrent delay time (T_{DIP}), discharging will be suspended by turning off the discharge control MOSFET (OD pin). This condition is called the discharge overcurrent status.

If the voltage of CS pin exceeds the short circuit detection voltage (V_{SIP}) and the condition lasts beyond the short circuit delay time (T_{SIP}), discharging will be suspended by turning off the discharge control MOSFET (OD pin). This condition is called the short circuit status. When the impedance between PB+ and PB-is higher than $1.4M\Omega$ (typ.), the discharge overcurrent condition will be released.

6. Abnormal Charge Current detection

Batteries under normal condition during the charging process, if the voltage of CS pin is lower than charger detection voltage (V_{CHA}), and this condition lasts for more than 12ms(typ.), the charging control MOSFET will be switched off (OC pin) to stop charging. This status is called “abnormal charge current detection”.

After entering the status of abnormal charge current detection, one way to revert it to normal is to have the CS pin voltage higher than charger detection voltage (V_{CHA}). Abnormal charge current detection voltage (V_{CHA}) for formularize:

$$\{I_{CHA} = |V_{CHA} / R_{ON}\}. R_{ON} \text{ is turn on resistance of MOSFET}$$

7. 0V Battery Charging Function “Unavailable”

When a battery which is internally short-circuited (0V battery) is connected, the unavailable 0V charging function will prohibit recharging. When the battery voltage equals to the 0V battery charge inhibition battery voltage (V_{0IN}) or lower, the charging control MOSFET gate is fixed to the PB- pin voltage to prohibit charging. When the battery voltage equals to the 0V battery charge inhibition battery voltage (V_{0IN}) or higher, charging can be implemented.

Package information

NOTE: All dimensions are in millimeters.

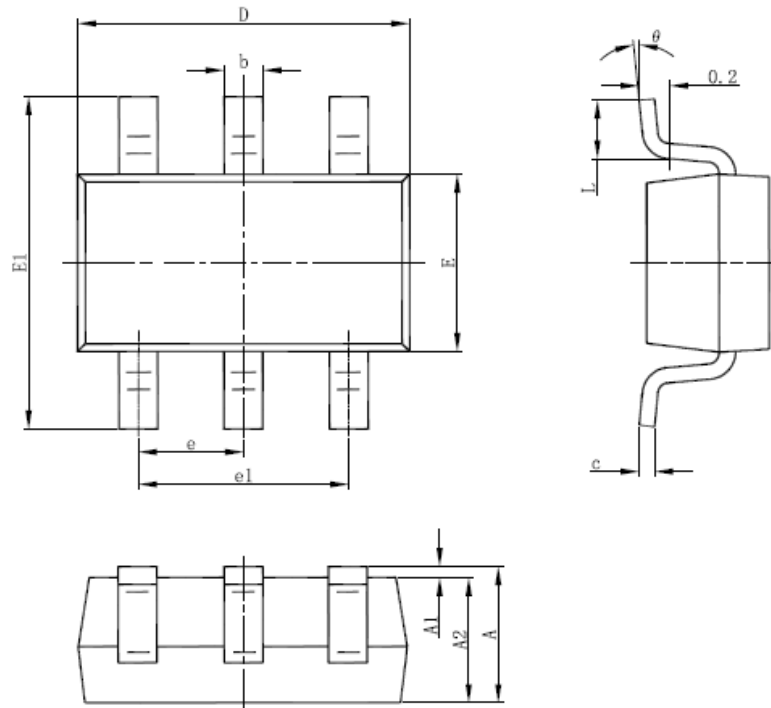

Symbol	Dimensions In Millimeters		Dimensions In Inches	
	Min	Max	Min	Max
A	1.050	1.250	0.041	0.049
A1	0.000	0.100	0.000	0.004
A2	1.050	1.150	0.041	0.045
b	0.300	0.500	0.012	0.020
c	0.100	0.200	0.040	0.008
D	2.820	3.020	0.111	0.119
E	1.500	1.700	0.059	0.067
E1	2.650	2.950	0.104	0.116
e	0.95 (BSC)		0.037 (BSC)	
e1	1.800	2.000	0.071	0.079
L	0.300	0.600	0.012	0.024
θ	0°	8°	0°	8°



Notice

1. Specification of the products displayed herein is subject to change without notice. Continuous development may necessitate changes in technical data without notice. GEMMICRO or anyone on its behalf assumes no responsibility or liability for any errors or inaccuracies.
2. Stresses beyond those listed under “Absolute Maximum Ratings” may cause permanent damage to the device. These are stress ratings only and functional operation of the device at these or any other conditions beyond those indicated in the operational sections of the specifications are not implied. Exposure to absolute maximum rating conditions for extended periods may affect device reliability.