

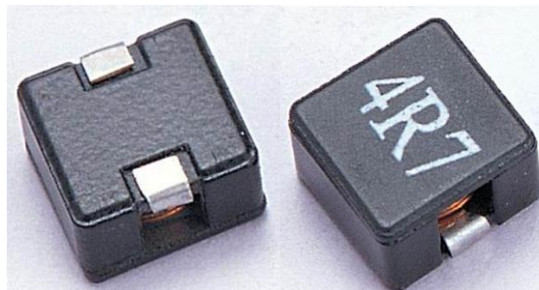
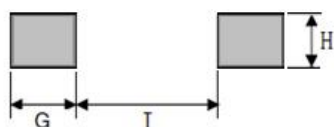
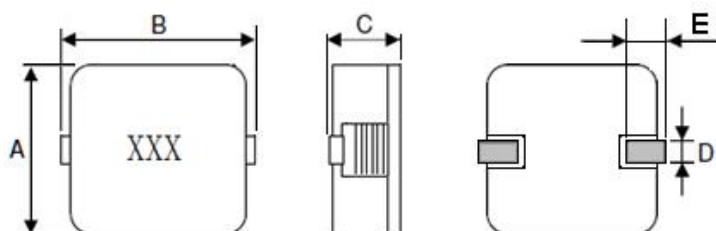

**◆ Features**

1. High current, low loss of iron powder core
2. Low profile for machine placement
3. Minimize electromagnetic interference
4. Suppress common mode noise
5. Prevent EMI effect via precise impedance
6. Custom design available

**◆ Dimensions(mm)**

**◆ Lead Free Part Numbering**

**SLB 2212 P 100 M T T**  
 ① ② ③ ④ ⑤ ⑥ ⑦

- ① Series Type;
- ② Dimension;
- ③ Material type;
- ④ Inductance 100=10UH;
- ⑤ Inductance Tolerance: M=±20%;
- ⑥ Company Code;
- ⑦ Packaging: T - Tape & reel;

单位: mm

Series	A	B	C	D	E	G	H	I
SLB2212P	22.0±1.0	22.5±1.0	12±0.4	3.5±1.0	5.5±1.0	7.0	6.0	9.0

**◆ Specification**

Part Number	Inductance (μH)	DCR(mΩ)		I <sub>rms</sub> (A) Typ	I <sub>sat</sub> (A) Typ	TEST FREQUENCY
		Typ	Max			
SLB2212P						
SLB2212P3R3MTT	3.3 ± 20%	1.70	1.87	29.0	45.0	100KHz/0.1V
SLB2212P6R8MTT	6.8 ± 20%	2.10	2.31	28.5	31.0	100KHz/0.1V
SLB2212P8R2MTT	8.2 ± 20%	2.70	2.97	25.5	30.0	100KHz/0.1V
SLB2212P100MTT	10 ± 20%	3.40	3.74	21.0	26.0	100KHz/0.1V
SLB2212P120MTT	12 ± 20%	4.30	4.73	19.0	25.0	100KHz/0.1V
SLB2212P220MTT	22 ± 20%	7.00	7.70	15.0	18.0	100KHz/0.1V
SLB2212P330MTT	33 ± 20%	13.20	14.52	11.5	15.0	100KHz/0.1V
SLB2212P470MTT	47 ± 20%	19.20	21.12	9.0	12.0	100KHz/0.1V
SLB2212P680MTT	68 ± 20%	27.30	30.03	7.5	9.5	100KHz/0.1V
SLB2212P820MTT	82 ± 20%	30.40	33.44	7.0	8.5	100KHz/0.1V

**NOTE:**

- All test data is referenced to 25°C ambient.
- I<sub>rms</sub>: DC current(A) that will cause an approximate ΔT of 50°C.
- I<sub>sat</sub>: DC current(A) that will cause L<sub>o</sub> to drop approximate 30%.
- Operating temperature range is P40°C to 125°C.
- The part temperature(ambient and temp rise) should not exceed 125°C under worse case operating conditions. Circuit design, component placement, PWB trace size and thickness, airflow and other cooling provision all affect the part temperature. Part temperature should be verified in the end application.

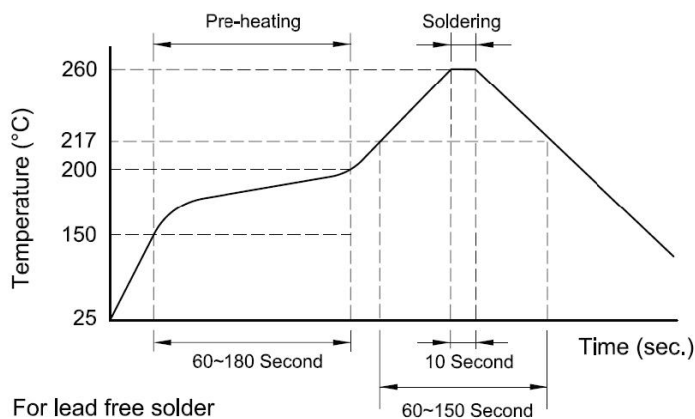
**◆ Recommended Soldering conditions**

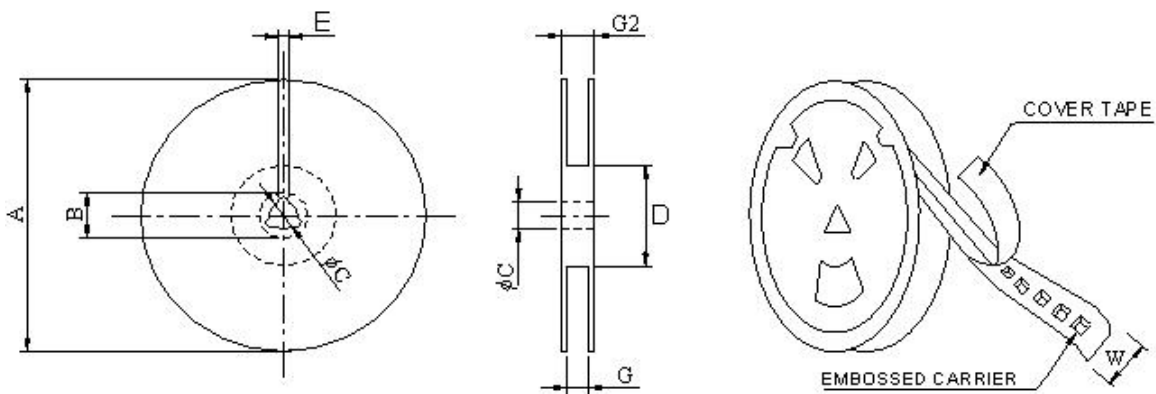
**◆ Packaging**

\*CARRIER TAPE WIDTH: W

Series	TYPE	A(Ref.)	B(Ref.)	C(Ref.)	D(Ref.)	E(Ref.)	G(Ref.)	G2(Ref.)
SLB2212P	13"*44mm	330±1	20±0.8	13±0.5	100±1	2.0±0.5	44.5±0.5	49±0.5

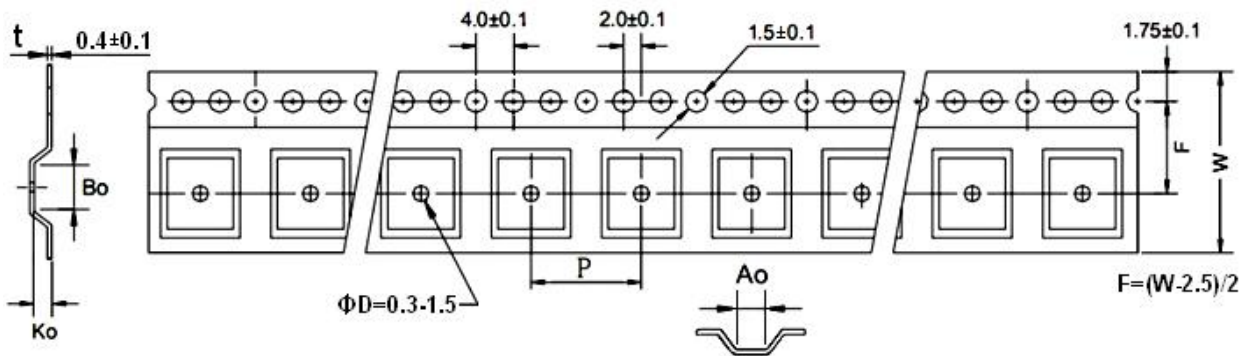

Series	QTY (Pcs/Reel)	Ao	Bo	Ko	W	P
SLB2212P	120	23.1	23.65	12.8	44	32

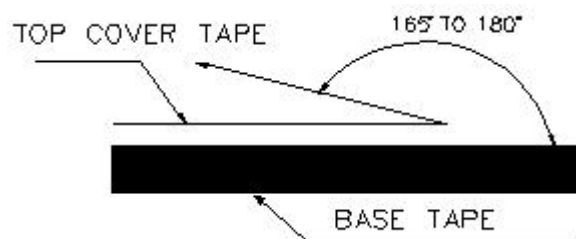

Typical Pulling Force: 10P130 grams