

# NCP81061

## VR12 Compatible Synchronous Buck Dual MOSFET Driver

The NCP81061 is a high performance dual MOSFET gate driver optimized to drive the gates of both high-side and low-side power MOSFETs in a synchronous buck converter. It can drive a 3 nF load with a 30 ns propagation delay and a 30 ns transition time.

Adaptive anti-cross-conduction and power saving operation circuit can provide a low switching loss and high efficiency solution for notebook and desktop systems. The Bidirectional EN pins can provide a fault signal to the controller when the gate driver detects an OVP or UVLO fault. Also, an under-voltage lockout function guarantees the outputs are low when supply voltage is low.

### Features

- Adaptive Anti-Cross-Conduction Circuit
- Integrated Bootstrap Diode
- Pre OV Function
- ZCD Detect
- Floating Top Driver Accommodates Boost Voltages of up to 35 V
- Output Disable Control Turns Off Both MOSFETs
- Under-voltage Lockout
- Power Saving Operation Under Light Load Conditions
- Direct Interface to NCP6151 and Other Compatible PWM Controllers
- Thermally Enhanced Package
- This is a Pb-Free Device

### Typical Applications

- Power Management solutions for Desktop and Server Systems



ON Semiconductor®

<http://onsemi.com>

### MARKING DIAGRAM



QFN16  
CASE 485AW

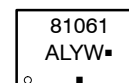

81061 = Specific Device Code  
A = Assembly Location  
L = Wafer Lot  
Y = Year  
W = Work Week  
▪ = Pb-Free Package

(\*Note: Microdot may be in either location)

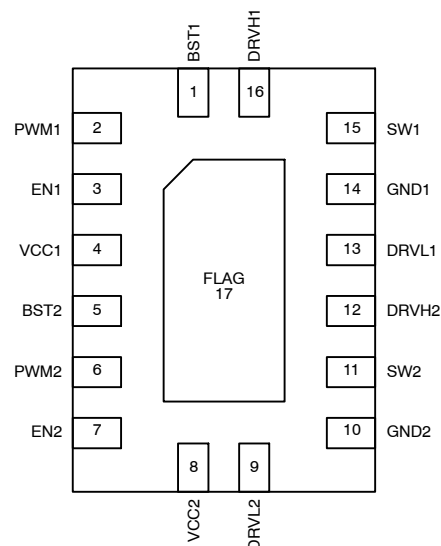

Pin Connections (Top View)

### ORDERING INFORMATION

Device	Package	Shipping†
NCP81061MNTWG	QFN16 (Pb-Free)	3000 / Tape & Reel

†For information on tape and reel specifications, including part orientation and tape sizes, please refer to our Tape and Reel Packaging Specification Brochure, BRD8011/D.

# NCP81061

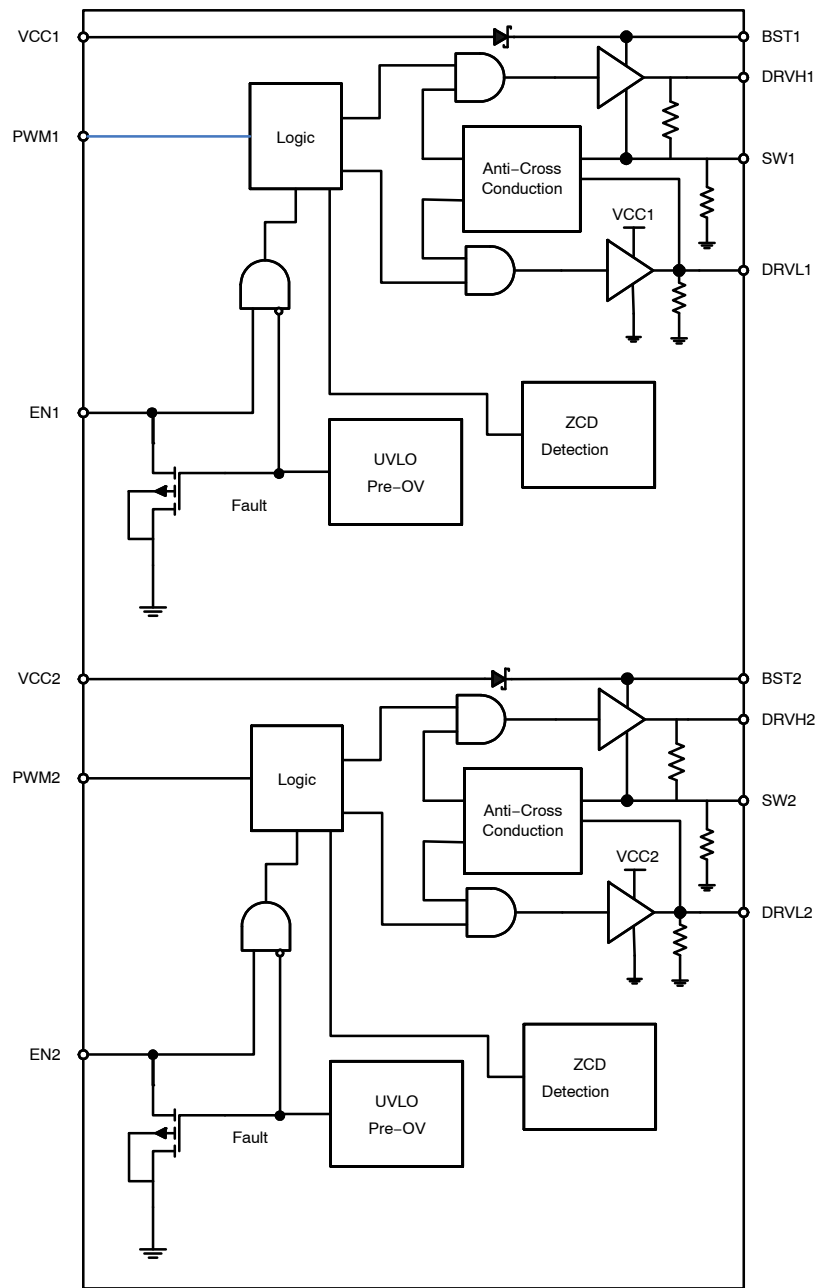

Figure 1. Block Diagram

# NCP81061

## PIN DESCRIPTIONS

Pin No.	Symbol	Description
1, 5	BST1, BST2	Floating bootstrap supply pin for high side gate driver. Connect the bootstrap capacitor between this pin and the SW pin.
2, 6	PWM1, PWM2	Control input. The PWM signal has four distinctive states: Low = Low Side FET Enabled, Mid = Diode Emulation Enabled, High = High Side FET Enabled.
3, 7	EN1, EN2	Logic input. A logic high to enable the part and a logic low to disable the part.
4, 8	VCC1, VCC2	Power supply input. Connect a bypass capacitor (0.1 $\mu$ F) from this pin to ground.
9, 13	DRVL1, DRVL2	Low side gate drive output. Connect to the gate of low side MOSFET.
10, 14	GND1, GND2	Bias and reference ground. All signals are referenced to this node.
11, 15	SW1, SW2	Switch node. Connect this pin to the source of the high side MOSFET and drain of the low side MOSFET.
12, 16	DRVH1, DRVH2	High side gate drive output. Connect to the gate of high side MOSFET.
17	FLAG	Thermal flag. There is no electrical connection to the IC. Connect to ground plane.

## APPLICATION CIRCUIT

## ABSOLUTE MAXIMUM RATINGS

### ELECTRICAL INFORMATION

Pin Symbol	Pin Name	V <sub>MAX</sub>	V <sub>MIN</sub>
VCC1, VCC2	Main Supply Voltage Input	15 V	-0.3 V
BST1, BST2	Bootstrap Supply Voltage	35 V wrt/ GND 40 V $\leq$ 50 ns wrt/ GND 15 V wrt/ SW	-0.3 V wrt/SW
SW1, SW2	Switching Node (Bootstrap Supply Return)	35 V 40 V $\leq$ 50 ns	-5 V -10 V (200ns)
DRVH1, DRVH2	High Side Driver Output	BST + 0.3 V	-0.3 V wrt/SW -2 V (<200 ns) wrt/SW
DRVL1, DRVL2	Low Side Driver Output	VCC + 0.3 V	-0.3 V DC -5 V (< 200 ns)
PWM1, PWM2	DRVH and DRVL Control Input	6.5 V	-0.3 V
EN1, EN2	Enable Pin	6.5 V	-0.3 V
GND1, GND2	Ground	0 V	0 V

### THERMAL INFORMATION

Pin Symbol	Pin Name	Typ	Unit
Thermal Characteristic (Note 1)	R <sub>θJA</sub>	29	°C/W
Operating Junction Temperature Range	T <sub>J</sub>	-10 to 150	°C
Operating Ambient Temperature Range		-10 to +125	°C
Maximum Storage Temperature Range	T <sub>STG</sub>	-55 to +150	°C
Moisture Sensitivity Level QFN Package	MSL	1	

\*The maximum package power dissipation must be observed.  
1. 5776 mm<sup>2</sup> Cu., 1 oz. thickness.

# NCP81061

**NCP81061 DRIVER ELECTRICAL CHARACTERISTICS Unless otherwise stated**  $-10^{\circ}\text{C} < T_A < +125^{\circ}\text{C}$ ;  $V_{CC1}/V_{CC2} = 4.5\text{ V} \sim 13.2\text{ V}$

Parameter	Test Conditions	Min	Typ	Max	Unit
-----------	-----------------	-----	-----	-----	------

## SUPPLY VOLTAGE

VCC Operation Voltage		4.5		13.2	V
Power ON Reset threshold			2.75	3.2	V

## UNDERVOLTAGE LOCKOUT

VCC Start Threshold		3.8	4.35	4.5	V
VCC UVLO Hysteresis		150	200	250	mV
Output Overvoltage Trip Threshold at Startup	Power Startup time, VCC > POR	2.1	2.25	2.4	V

## SUPPLY CURRENT

Normal mode	ICC + IBST, EN = 5 V, PWM = OSC, $F_{sw} = 100\text{ kHz}$ , $C_{LOAD} = 3\text{ nF}$		24.4		mA
Standby Current	ICC + IBST, EN=GND		1.0	3.8	mA
Standby Current	ICC + IBST, EN = HIGH, PWM = LOW, No loading on DRVH & DRVL		4.2		mA
Standby Current	ICC + IBST, EN = HIGH, PWM = HIGH, No loading on DRVH & DRVL		4.4		mA

## BOOTSTRAP DIODE

Forward Voltage	$V_{VCC} = 12\text{ V}$ , forward bias current = 2 mA	0.1	0.4	0.6	V
-----------------	---	-----	-----	-----	---

## PWM INPUT

PWM Input High		3.4			V
PWM Mid-State		1.3		2.7	V
PWM Input Low				0.7	V
ZCD blanking timer			250		ns

## HIGH SIDE DRIVER (VCC = 12 V)

Output Impedance, Sourcing Current	VBST-VSW = 12 V		2.0	3.5	$\Omega$
Output Impedance, Sinking Current	VBST-VSW = 12 V		1.0	2.0	$\Omega$
DRVH Rise Time $t_{r_{DRVH}}$	$V_{VCC} = 12\text{ V}$ , 3 nF load, VBST-VSW = 12 V		16	30	ns
DRVH Fall Time $t_{f_{DRVH}}$	$V_{VCC} = 12\text{ V}$ , 3 nF load, VBST-VSW = 12 V		11	25	ns
DRVH Turn-Off Propagation Delay $t_{pd_{DRVH}}$	$C_{LOAD} = 3\text{ nF}$	8.0		30	ns
DRVH Turn-On Propagation Delay $t_{pdh_{DRVH}}$	$C_{LOAD} = 3\text{ nF}$			30	ns
SW pull down resistance	SW to PGND		45		k $\Omega$
DRVH pull down resistance	DRVH to SW, BST-SW = 0 V		45		k $\Omega$

## HIGH SIDE DRIVER (VCC = 5 V)

Output Impedance, Sourcing Current	VBST-VSW = 5 V		4.5		$\Omega$
Output Impedance, Sinking Current	VBST-VSW = 5 V		2.9		$\Omega$
DRVH Rise Time $t_{r_{DRVH}}$	$V_{VCC} = 5\text{ V}$ , 3 nF load, VBST-VSW = 5 V		30		ns
DRVH Fall Time $t_{f_{DRVH}}$	$V_{VCC} = 5\text{ V}$ , 3 nF load, VBST-VSW = 5 V		27		ns
DRVH Turn-Off Propagation Delay $t_{pd_{DRVH}}$	$C_{LOAD} = 3\text{ nF}$		20		ns
DRVH Turn-On Propagation Delay $t_{pdh_{DRVH}}$	$C_{LOAD} = 3\text{ nF}$		27		ns
SW pull down resistance	SW to PGND		45		k $\Omega$
DRVH pull down resistance	DRVH to SW, BST-SW = 0 V		45		k $\Omega$

# NCP81061

**NCP81061 DRIVER ELECTRICAL CHARACTERISTICS Unless otherwise stated**  $-10^{\circ}\text{C} < T_A < +125^{\circ}\text{C}$ ;  $V_{CC1}/V_{CC2} = 4.5\text{ V} \sim 13.2\text{ V}$

Parameter	Test Conditions	Min	Typ	Max	Unit
<b>LOW SIDE DRIVER (VCC = 12 V)</b>					
Output Impedance, Sourcing Current			2.0	3.5	$\Omega$
Output Impedance, Sinking Current			0.8	1.8	$\Omega$
DRVL Rise Time $t_{rDRVL}$	$C_{LOAD} = 3\text{ nF}$		16	35	ns
DRVL Fall Time $t_{fDRVL}$	$C_{LOAD} = 3\text{ nF}$		11	15	ns
DRVL Turn-Off Propagation Delay $tpd_{DRVL}$	$C_{LOAD} = 3\text{ nF}$			35	ns
DRVL Turn-On Propagation Delay $tpdh_{DRVL}$	$C_{LOAD} = 3\text{ nF}$	8.0		30	ns
DRVL pull down resistance	DRVL to PGND, $V_{CC} = \text{PGND}$		45		$\text{k}\Omega$

<b>LOW SIDE DRIVER (VCC = 5 V)</b>					
Output Impedance, Sourcing Current			4.5		$\Omega$
Output Impedance, Sinking Current			2.4		$\Omega$
DRVL Rise Time $t_{rDRVL}$	$C_{LOAD} = 3\text{ nF}$		30		ns
DRVL Fall Time $t_{fDRVL}$	$C_{LOAD} = 3\text{ nF}$		22		ns
DRVL Turn-Off Propagation Delay $tpd_{DRVL}$	$C_{LOAD} = 3\text{ nF}$		27		ns
DRVL Turn-On Propagation Delay $tpdh_{DRVL}$	$C_{LOAD} = 3\text{ nF}$		12		ns
DRVL pull down resistance	DRVL to PGND, $V_{CC} = \text{PGND}$		45		$\text{k}\Omega$

## EN INPUT

Input Voltage High		2.0			V
Input Voltage Low				1.0	V
Hysteresis			500		mV
Normal mode bias current		-1		1	$\mu\text{A}$
Fault mode Enable pin pull down current		4		30	mA
Propagation Delay Time			20	40	ns

## SW Node

SW node leakage current				20	$\mu\text{A}$
Zero Cross Detection Threshold Voltage	SW to $-20\text{ mV}$ , ramp slowly until BG go off. (start in DCM mode)		-6		mV

## DECODER TRUTH TABLE

PWM INPUT	ZCD	DRVL	DRVH
PWM High	ZCD Reset	Low	High
PWM Mid	Positive current through the inductor	High	Low
PWM Mid	Zero current through the inductor	Low	Low
PWM Low	ZCD Reset	High	Low

# NCP81061

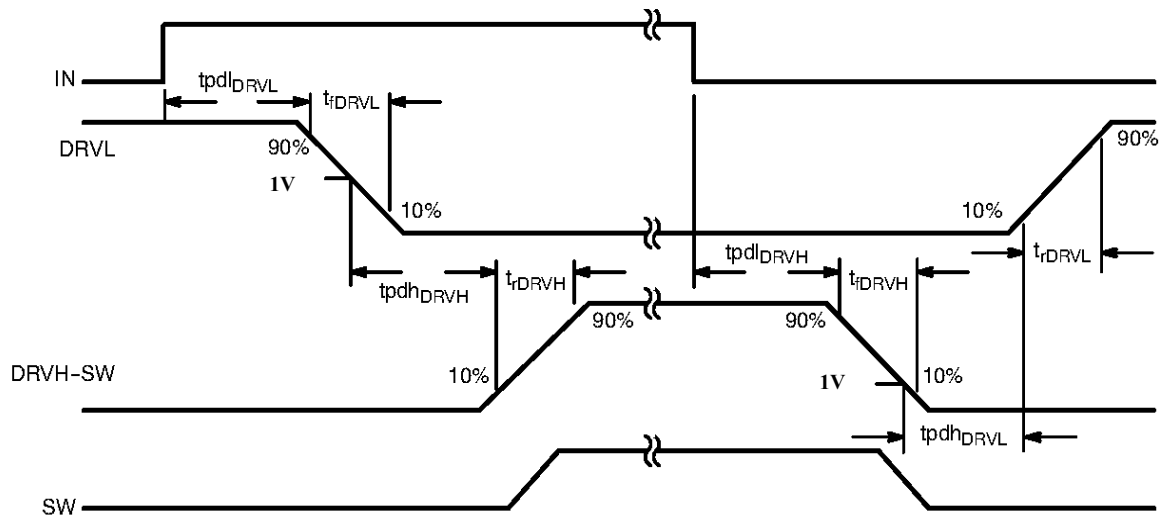

Figure 2.

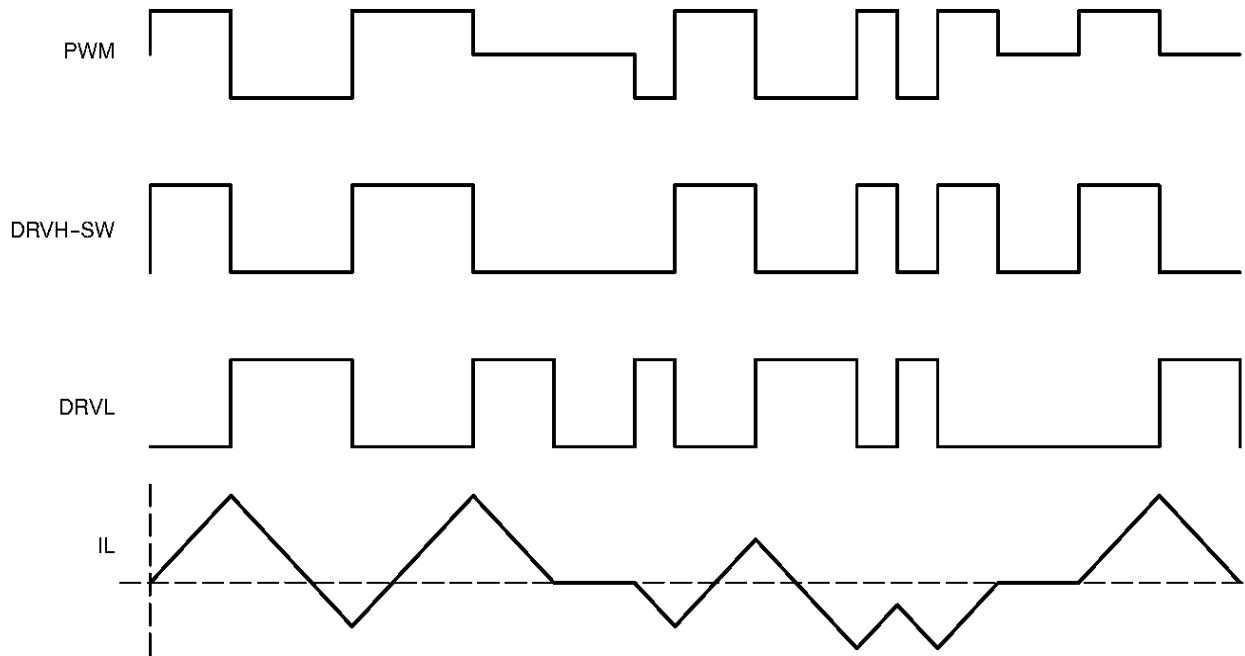

Figure 3. Timing Diagram

APPLICATION INFORMATION

The NCP81061 gate driver is a dual phase MOSFET driver designed for driving N-channel MOSFETs in a synchronous buck converter topology. The NCP81061 is designed to work with ON Semiconductor’s NCP6151 multi-phase controller.

**Under-voltage Lockout**

DRVH and DRVL are held low until V<sub>CC</sub> reaches 4.5 V during start-up. The PWM signals will control the gate status when the V<sub>CC</sub> threshold is exceeded. If V<sub>CC</sub> decreases to 200 mV below the threshold, the driver outputs will be forced low until V<sub>CC</sub> rises above the start-up threshold.

**Power-On Reset**

The power-on reset feature is used to protect a gate driver from abnormal status during start-up. When the initial V<sub>CC</sub> soft-start voltage is higher than 2.75 V, the gate driver will monitor the SW pin. If the SW pin is higher than 2.25 V, bottom gate will be forced high to discharge the output capacitor. The fault mode will be latched and the EN pin will be forced low until the driver is recycled. When the V<sub>CC</sub> voltage is higher than 4.5 V, and EN is high, the driver will enter normal operation.

**Bi-directional EN Signal**

When the driver is in a fault mode such as Power-On Reset and Under-Voltage Lockout, it will de-assert the EN pin by pulling it low. This will pull down the DRON pin of the controller as well.

**PWM Input and Zero Cross Detect (ZCD)**

The PWM input, along with EN and ZCD, control the state of DRVH and DRVL. When PWM is set high, DRVH will be set high after the adaptive non-overlap delay. When PWM is set low, DRVL will be set high after the adaptive non-overlap delay. When the PWM is set to the mid state, DRVH will be set low, and after the adaptive non-overlap delay, DRVL will be set high. DRVL remains high during the ZCD blanking time. When the timer is expired, the SW pin will be monitored for zero cross detection. After the detection, the DRVL will be set low.

**Adaptive Non-overlap**

The non-overlap dead time control is used to avoid shoot-through current from damaging the power MOSFETs. When the PWM signal is pulled high, DRVL will start to go low after a propagation delay (tpd<sub>DRVL</sub>). The driver will monitor the DRVL voltage until a threshold where an internal timer (tpdh<sub>DRVH</sub>) will delay turn-on of the high-side MOSFET. When the PWM signal is pulled low, DRVH will start to go low after a propagation delay (tpd<sub>DRVH</sub>). The driver will monitor the difference between the DRVH and SW voltages until a threshold where an internal timer (tpdh<sub>DRVL</sub>) delays turn-on of the low-side MOSFET.

**Layout Guidelines**

Layout for DC-DC converter is very important. The bootstrap and V<sub>CC</sub> bypass capacitors should be placed as close the driver IC as possible.

Connect GND pin to a local ground plane. The ground plane can provide a good return path for gate drives and reduce the ground noise. The thermal slug should be tied to the ground plane for good heat dissipation. To minimize the ground loop for low side MOSFET, the driver GND pin should be close to the low-side MOSFET source pin. The gate drive trace should be routed to minimize the length, with a minimum width of 20 mils.

**Gate Driver Power Loss Calculation**

The gate driver power loss consists of the gate drive loss and quiescent power loss.

The equation below can be used to calculate the power dissipation of the gate driver. Where Q<sub>GMF</sub> is the total gate charge for each main MOSFET and Q<sub>QSF</sub> is the total gate charge for each synchronous MOSFET.

$$P_{DRV} = \left[ \frac{f_{SW}}{2 \times n} \times (n_{MF} \times Q_{GMF} + n_{SF} \times Q_{QFS}) + I_{CC} \right] \times V_{CC}$$

# NCP81061

## PACKAGE DIMENSIONS

**QFN16, 2.5x3.5, 0.5P**  
CASE 485AW  
ISSUE O

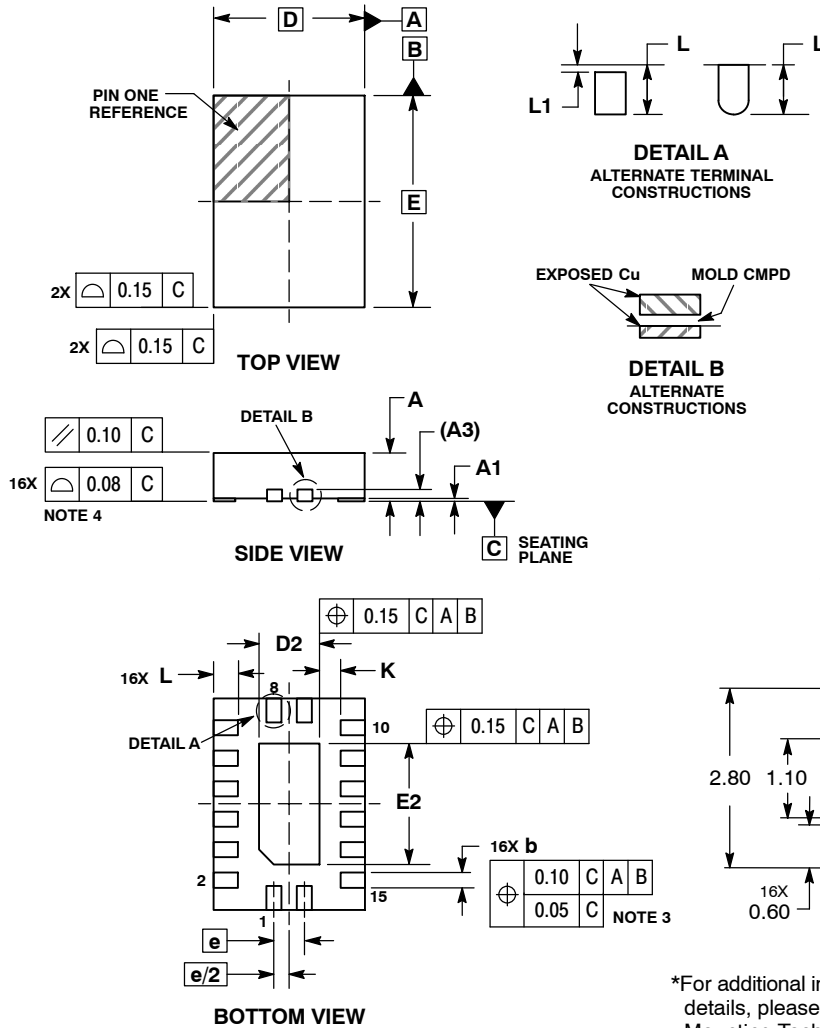

**NOTES:**

1. DIMENSIONING AND TOLERANCING PER ASME Y14.5M, 1994.
2. CONTROLLING DIMENSION: MILLIMETERS.
3. DIMENSIONS b APPLIES TO PLATED TERMINAL AND IS MEASURED BETWEEN 0.15 AND 0.30 MM FROM TERMINAL.
4. COPLANARITY APPLIES TO THE EXPOSED PAD AS WELL AS THE TERMINALS.

DIM	MILLIMETERS	
	MIN	MAX
A	0.80	1.00
A1	0.00	0.05
A3	0.20	REF
b	0.20	0.30
D	2.50	BSC
D2	0.85	1.15
E	3.50	BSC
E2	1.85	2.15
e	0.50	BSC
K	0.20	---
L	0.35	0.45
L1	---	0.15

**SOLDERING FOOTPRINT\***

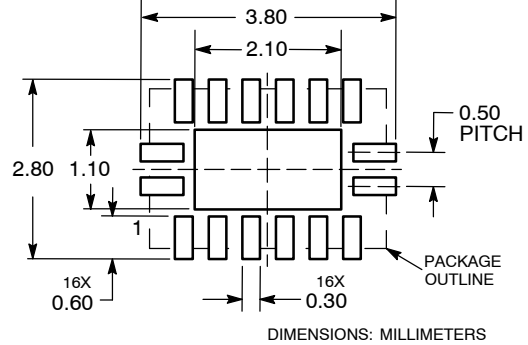

\*For additional information on our Pb-Free strategy and soldering details, please download the ON Semiconductor Soldering and Mounting Techniques Reference Manual, SOLDERRM/D.

**ON Semiconductor** and are registered trademarks of Semiconductor Components Industries, LLC (SCILLC). SCILLC owns the rights to a number of patents, trademarks, copyrights, trade secrets, and other intellectual property. A listing of SCILLC's product/patent coverage may be accessed at [www.onsemi.com/site/pdf/Patent-Marking.pdf](http://www.onsemi.com/site/pdf/Patent-Marking.pdf). SCILLC reserves the right to make changes without further notice to any products herein. SCILLC makes no warranty, representation or guarantee regarding the suitability of its products for any particular purpose, nor does SCILLC assume any liability arising out of the application or use of any product or circuit, and specifically disclaims any and all liability, including without limitation special, consequential or incidental damages. "Typical" parameters which may be provided in SCILLC data sheets and/or specifications can and do vary in different applications and actual performance may vary over time. All operating parameters, including "Typicals" must be validated for each customer application by customer's technical experts. SCILLC does not convey any license under its patent rights nor the rights of others. SCILLC products are not designed, intended, or authorized for use as components in systems intended for surgical implant into the body, or other applications intended to support or sustain life, or for any other application in which the failure of the SCILLC product could create a situation where personal injury or death may occur. Should Buyer purchase or use SCILLC products for any such unintended or unauthorized application, Buyer shall indemnify and hold SCILLC and its officers, employees, subsidiaries, affiliates, and distributors harmless against all claims, costs, damages, and expenses, and reasonable attorney fees arising out of, directly or indirectly, any claim of personal injury or death associated with such unintended or unauthorized use, even if such claim alleges that SCILLC was negligent regarding the design or manufacture of the part. SCILLC is an Equal Opportunity/Affirmative Action Employer. This literature is subject to all applicable copyright laws and is not for resale in any manner.

**PUBLICATION ORDERING INFORMATION**

**LITERATURE FULFILLMENT:**  
Literature Distribution Center for ON Semiconductor  
P.O. Box 5163, Denver, Colorado 80217 USA  
**Phone:** 303-675-2175 or 800-344-3860 Toll Free USA/Canada  
**Fax:** 303-675-2176 or 800-344-3867 Toll Free USA/Canada  
**Email:** [orderlit@onsemi.com](mailto:orderlit@onsemi.com)

**N. American Technical Support:** 800-282-9855 Toll Free USA/Canada  
**Europe, Middle East and Africa Technical Support:**  
Phone: 421 33 790 2910  
**Japan Customer Focus Center**  
Phone: 81-3-5817-1050

**ON Semiconductor Website:** [www.onsemi.com](http://www.onsemi.com)  
**Order Literature:** <http://www.onsemi.com/orderlit>

For additional information, please contact your local Sales Representative