



FIN1215 / FIN1216 / FIN1217/ FIN1218 LVDS 21-Bit Serializers / De-Serializers

Features

- Low Power Consumption
- 20MHz to 85MHz Shift Clock Support
- 50% Duty Cycle on the Clock Output of Receiver
- ±1V Common-mode Range ~1.2V
- Narrow Bus Reduces Cable Size and Cost
- High Throughput: 1.785Gbps
- Up to 595Mbps per Channel
- Internal PLL with No External Components
- Compatible with TIA/EIA-644 Specification
- Offered in 48-lead TSSOP Packages

Description

The FIN1217 and FIN1215 transform 21-bit wide parallel LVTTTL (Low-Voltage TTL) data into three serial LVDS (Low-Voltage Differential Signaling) data streams. A phase-locked transmit clock is transmitted in parallel with the data stream over a separate LVDS link. Every cycle of transmit clock, 21 bits of input LVTTTL data are sampled and transmitted.

The FIN1216 and FIN1218 receives and converts the three serial LVDS data streams back into 21 bits of LVTTTL data. Table 1 provides a matrix summary of the serializers and de-serializers available. For the FIN1217, at a transmit clock frequency of 85MHz, 21 bits of LVTTTL data are transmitted at a rate of 595Mbps per LVDS channel.

These chipsets solve EMI and cable size problems associated with wide and high-speed TTL interfaces.

Ordering Information

Part Number	Operating Temperature Range	 Eco Status	Package	Packing Method
FIN1215MTDX	-40 to + 85°C	RoHS	48-Lead Thin Shrink Small Outline Package (TSSOP)	Tape and Reel
FIN1216MTDX				
FIN1217MTDX				
FIN1218MTDX (Preliminary)				

 For Fairchild's definition of Eco Status, please visit: http://www.fairchildsemi.com/company/green/rohs_green.html.

Block Diagrams

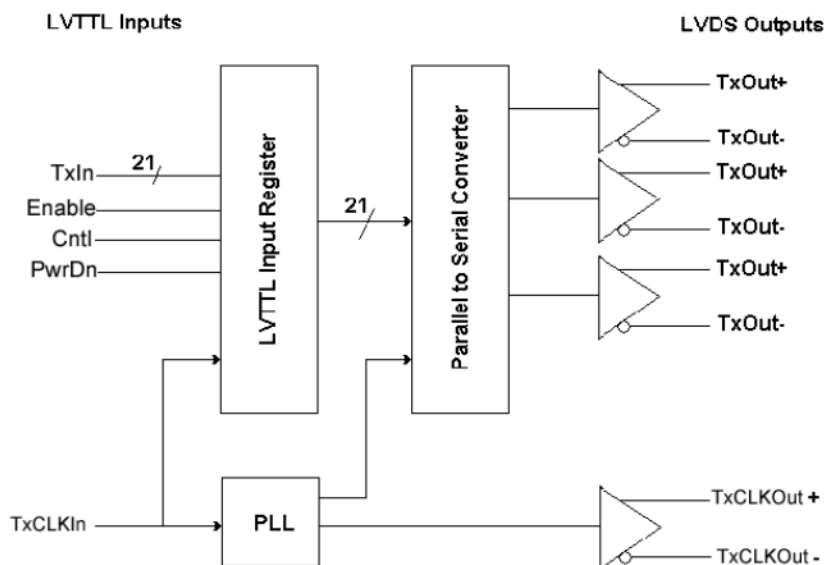

Figure 1. FIN1217 / FIN1215 Transmitter Functional Diagram

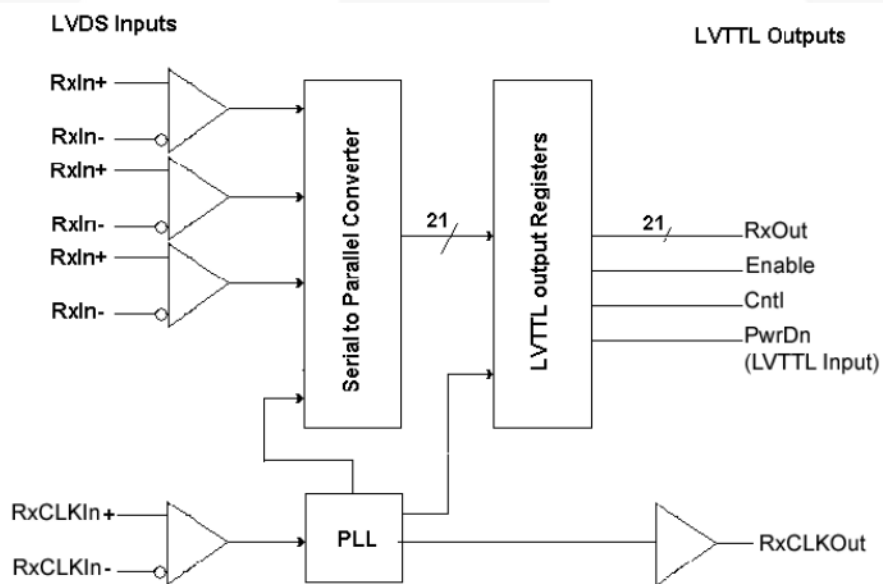

Figure 2. FIN1218 / FIN1216 Receiver Functional Diagram

Table 1. Serializers / De-Serializers Chip Matrix

Part	CLK Frequency	LVTTTL IN	LVDS OUT	LVDS IN	LVTTTL OUT	Package
FIN1215	66	21	3			48-Lead TSSOP
FIN1216	66			3	21	48-Lead TSSOP
FIN1217	85	21	3			48-Lead TSSOP
FIN1218	85			3	21	48-Lead TSSOP

Transmitters

Pin Configuration

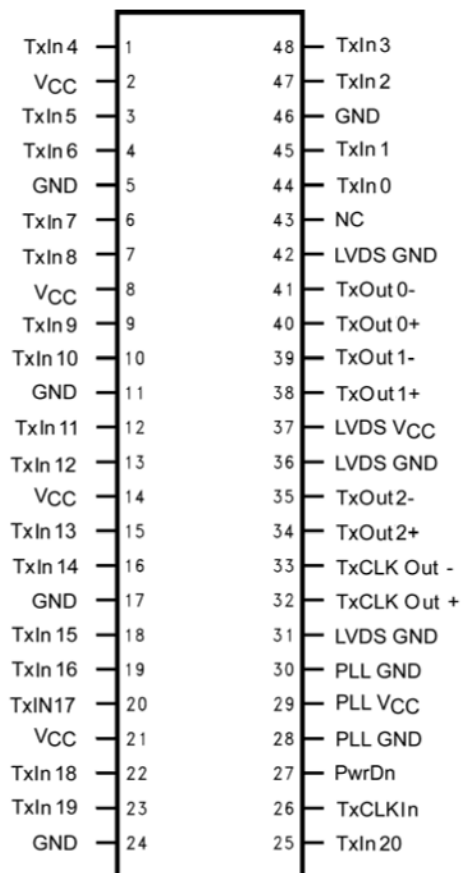

Figure 3. FIN1217 / FIN1215 (21:3 Transmitter)

Pin Definitions

Pin Names	I/O Type	# of Pins	Description of Signals
TxIn	I	21	LVTTTL Level Inputs
TxCKLIn	I	1	LVTTTL Level Clock Input; the rising edge is for data strobe
TxOut+	O	3	Positive LVDS Differential Data Output
TxOut	O	3	Negative LVDS Differential Data Output
TxCLKOut+	O	1	Positive LVDS Differential Clock Output
TxCLKOut-	O	1	Negative LVDS Differential Clock Output
/PwrDn	I	1	LVTTTL Level Power-Down Input; assertion (LOW) puts the outputs in high-impedance state
PLL VCC	I	1	Power Supply Pin for LVDS Outputs
PLL GND	I	2	Ground Pins for PLL
LVDS VCC	I	1	Power Supply Pins for LVDS Outputs
LVDS GND	I	3	Ground Pin for LVDS Outputs
VCC	I	4	Power Supply Pins for LVTTTL Inputs
GND	I	5	Ground Pins for LVTTTL Inputs
NC			No Connect

Receivers

Pin Configuration

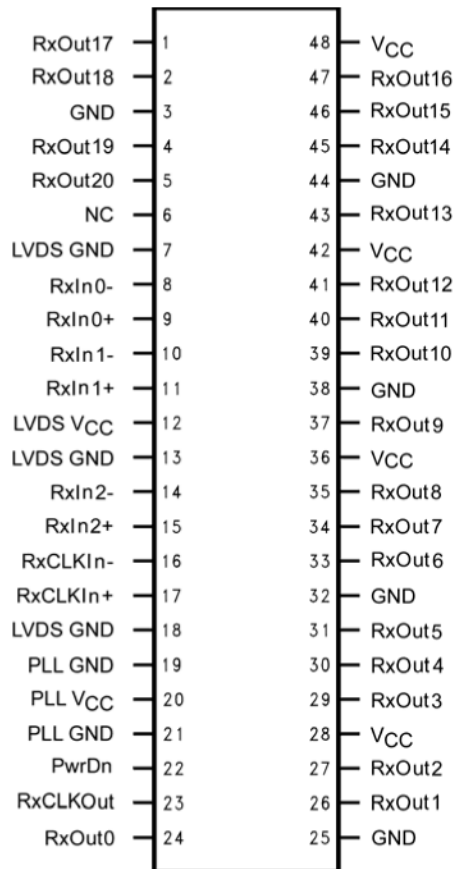

Figure 4. FIN1216 / FIN1218 (3:21 Receiver)

Pin Definitions

Pin Names	I/O Type	# of Pins	Description of Signals
RxIn	I	3	Negative LVDS Differential Data Output
RxIn+	I	3	Positive LVDS Differential Data Output
RxCLKIn-	I	1	Negative LVDS Differential Clock Output
RxCLKIn+	I	1	Positive LVDS Differential Clock Output
RxOut-	O	21	LVTTL Level Data Outputs Goes HIGH for /PwrDn LOW
RxCLKOut	O	1	LVTTL Level Clock Output
/PwrDn	I	1	LVTTL Level Input; Refer to Transmitter and Receiver Power-up and Power-down Operation Truth Table
PLL V _{CC}	I	1	Power Supply Pin for PLL
PLL GND	I	2	Ground Pins for PLL
LVDS V _{CC}	I	1	Power Supply Pins for LVDS Inputs
LVDS GND	I	3	Ground Pin for LVDS Inputs
V _{CC}	I	4	Power Supply Pins for LVTTL Outputs
GND	I	5	Ground Pins for LVTTL Outputs
NC			No Connect

Truth Tables

Transmitter

Inputs			Outputs	
TxIn	TxCLKIn	PwrDn ⁽¹⁾	TxOut±	TxCLKOut±
Active	Active	HIGH	LOW / HIGH	LOW / HIGH
Active	LOW / HIGH High Impedance	HIGH	LOW / HIGH	Don't Care ⁽²⁾
Floating	Active	HIGH	LOW	LOW / HIGH
Floating	Floating	HIGH	LOW	Don't Care ⁽²⁾
Don't Care	Don't Care	LOW	High Impedance	High Impedance

Notes:

1. The outputs of the transmitter or receiver remain in a high-impedance state until V_{CC} reaches 2V.
2. TxCLKOut± settles at a free running frequency when the part is powered up, PwrDn is HIGH and the TxCLKIn is a steady logic level LOW / HIGH / high-impedance.

Receiver

Inputs			Outputs	
RxIn±	RxCLKIn±	/PwrDn ⁽³⁾	RxOut	RxCLKOut
Active	Active	HIGH	LOW / HIGH	LOW / HIGH
Active	Failsafe Condition ⁽⁴⁾	HIGH	Last Valid State	HIGH
Failsafe Condition ⁽⁴⁾	Active	HIGH	HIGH	LOW / HIGH
Failsafe Condition ⁽⁴⁾	Failsafe Condition ⁽⁴⁾	HIGH	Last Valid State ⁽⁵⁾	HIGH
Don't Care	Don't Care	LOW	LOW	HIGH

Notes:

3. The outputs of the transmitter or receiver remain in a high-impedance state until V_{CC} reaches 2V.
4. Failsafe condition is defined as the input being terminated and un-driven, shorted, or open.
5. If RxCLKIn± is removed prior to the RxIn± data being removed, RxOut is the last valid state. If RxIn± data is removed prior to RxCLKIn± being removed, RxOut is HIGH.

Absolute Maximum Ratings

Stresses exceeding the absolute maximum ratings may damage the device. The device may not function or be operable above the recommended operating conditions and stressing the parts to these levels is not recommended. In addition, extended exposure to stresses above the recommended operating conditions may affect device reliability. The absolute maximum ratings are stress ratings only.

Symbol	Parameter		Min.	Max.	Unit
V _{CC}	Power Supply Voltage		-0.3	+4.6	V
V _{TTL}	TTL/CMOS Input/Output Voltage		-0.5	+4.6	V
V _{LVDS}	LVDS Input/Output Voltage		-0.3	+4.6	V
I _{OSD}	LVDS Output Short-Circuit Current			Continuous	
T _{STG}	Storage Temperature Range		-65	+150	°C
T _J	Maximum Junction Temperature, Soldering 4 seconds			+150	°C
T _L	Lead Temperature			+260	°C
ESD	Human Body Model, JESD22-A114 (1.5kΩ, 100pF)	LVDS I/O to Ground		10.0	kV
		All Pins (FIN1215, FIN1217)		6.5	
	Machine Model, JESD22-A115, 0Ω, 200pF	FIN1215, FIN1217 Only		>400	V

Recommended Operating Conditions

The Recommended Operating Conditions table defines the conditions for actual device operation. Recommended operating conditions are specified to ensure optimal performance to the datasheet specifications. Fairchild does not recommend exceeding them or designing to Absolute Maximum Ratings.

Symbol	Parameter	Min.	Max.	Unit
V _{CC}	Supply Voltage	3.0	3.6	V
T _A	Operating Temperature	-40	+85	°C
V _{CCNPP}	Maximum Supply Noise Voltage ⁽⁶⁾		100	mV _{PP}

Note:

- 100mV V_{CC} noise should be tested for frequency at least up to 2MHz. All the specifications should be met under such a noise level.

Transmitter DC Electrical Characteristics

Typical values are at $T_A=25^\circ\text{C}$ and with $V_{CC}=3.3\text{V}$; minimum and maximum are at over supply voltages and operating temperatures ranges, unless otherwise specified.

Symbol	Parameter	Test Conditions	Min.	Typ.	Max.	Units	
Transmitter LVTTTL Input Characteristics							
V_{IH}	Input High Voltage		2.0		V_{CC}	V	
V_{IL}	Input Low Voltage		GND		0.8	V	
V_{IK}	Input Clamp Voltage	$I_{IK}=-18\text{mA}$		-0.79	-1.50	V	
I_{IN}	Input Current	$V_{IN}=0.4\text{V to }4.6\text{V}$		1.8	10.0	μA	
		$V_{IN}=\text{GND}$	-10.0	0			
Transmitter LVDS Output Characteristics⁽⁷⁾							
V_{OD}	Output Differential Voltage	$R_L=100\Omega$, Figure 4	250		450	mV	
ΔV_{OD}	V_{OD} Magnitude Change from Differential LOW-to-HIGH				35	mV	
V_{OS}	Offset Voltage		1.125	1.250	1.375	V	
ΔV_{OS}	Offset Magnitude Change from Differential LOW-to-HIGH			25		mV	
I_{OS}	Short-Circuit Output Current	$V_{OUT}=0\text{V}$		-3.5	-5.0	mA	
I_{OZ}	Disabled Output Leakage Current	$D_0=0\text{V to }4.6\text{V}$, $/PwrDn=0\text{V}$		± 1.0	± 10.0	μA	
Transmitter Supply Current							
I_{CCWT}	21:3 Transmitter Power Supply Current for Worst-Case Pattern with Load ^(8,9)	$R_L=100\Omega$, Figure 7	33MHz		28.0	46.2	mA
			40MHz		29.0	51.7	
			65MHz		34.0	57.2	
			85MHz ⁽¹⁰⁾		39.0	62.7	
I_{CCPDT}	Powered-Down Supply Current	$/PwrDn=0.8\text{V}$		10.0	55.0	μA	

Notes:

- Positive current values refer to the current flowing into device and negative values means current flowing out of pins. Voltages are referenced to ground unless otherwise specified (except ΔV_{OD} and V_{OD}).
- The power supply current for both transmitter and receiver can be different with the number of active I/O channels.
- The 16-grayscale test pattern tests device power consumption for a "typical" LCD display pattern. The test pattern approximates signal switching needed to produce groups of 16 vertical strips across the display.
- FIN1217 only.

Transmitter AC Electrical Characteristics

Typical values are at over supply voltages and operating temperatures ranges, unless otherwise specified.

Symbol	Parameter	Conditions	Min.	Typ.	Max.	Units
t _{TCP}	Transmit Clock Period	Figure 10	11.76	T	50.00	ns
t _{TCH}	Transmit Clock (TxCLKIn) HIGH Time		0.35	0.50	0.65	T
t _{TCL}	Transmit Clock LOW Time		0.35	0.50	0.65	T
t _{CLKT}	TxCLKIn Transition Time (Rising and Falling)	10% to 90% Figure 11	1.0		6.0	ns
t _{JIT}	TxCLKIn Cycle-to-Cycle Jitter				3.0	ns
t _{XIT}	TxIn Transition Time		1.5		6.0	ns

LVDS Transmitter Timing Characteristics

t _{TLH}	Differential Output Rise Time (20% to 80%)	Figure 8		0.75	1.50	ns
t _{THL}	Differential Output Fall Time (80% to 20%)			0.75	1.50	ns
t _{STC}	TxIn Setup to TxCLNIn	Figure 10 f=85MHz FIN1217 only	2.5			ns
t _{HTC}	TxIn Holds to TCLKIn		0			ns
t _{TPDD}	Transmitter Power-Down Delay	Figure 17 ⁽¹¹⁾			100	ns
t _{TCCD}	Transmitter Clock Input to Clock Output Delay	Figure 13 T _A =25°C, V _{CC} =3.3V	2.8	5.5	6.8	ns

Transmitter Output Data Jitter (f=40 MHz)⁽¹²⁾

t _{TPPB0}	Transmitter Output Pulse Position of Bit 0	Figure 20 $a = \frac{1}{f \times 7}$	-0.25	0	0.25	ns
t _{TPPB1}	Transmitter Output Pulse Position of Bit 1		a-0.25	a	a+0.25	ns
t _{TPPB2}	Transmitter Output Pulse Position of Bit 2		2a-0.25	2a	2a+0.25	ns
t _{TPPB3}	Transmitter Output Pulse Position of Bit 3		3a-0.25	3a	3a+0.25	ns
t _{TPPB4}	Transmitter Output Pulse Position of Bit 4		4a-0.25	4a	4a+0.25	ns
t _{TPPB5}	Transmitter Output Pulse Position of Bit 5		5a-0.25	5a	5a+0.25	ns
t _{TPPB6}	Transmitter Output Pulse Position of Bit 6		6a-0.25	6a	6a+0.25	ns

Transmitter Output Data Jitter (f=65 MHz)⁽¹²⁾

t _{TPPB0}	Transmitter Output Pulse Position of Bit 0	Figure 20 $a = \frac{1}{f \times 7}$	-0.2	0	0.2	ns
t _{TPPB1}	Transmitter Output Pulse Position of Bit 1		a-0.2	a	a+0.2	ns
t _{TPPB2}	Transmitter Output Pulse Position of Bit 2		2a-0.2	2a	2a+0.2	ns
t _{TPPB3}	Transmitter Output Pulse Position of Bit 3		3a-0.2	3a	3a+0.2	ns
t _{TPPB4}	Transmitter Output Pulse Position of Bit 4		4a-0.2	4a	4a+0.2	ns
t _{TPPB5}	Transmitter Output Pulse Position of Bit 5		5a-0.2	5a	5a+0.2	ns
t _{TPPB6}	Transmitter Output Pulse Position of Bit 6		6a-0.2	6a	6a+0.2	ns

Continued on following page...

Transmitter AC Electrical Characteristics (Continued)

Symbol	Parameter	Conditions	Min.	Typ.	Max.	Units
Transmitter Output Data Jitter (f=85 MHz, FIN1217 only)⁽¹²⁾						
t _{TPPB0}	Transmitter Output Pulse Position of Bit 0	Figure 20 $a = \frac{1}{f \times 7}$	-0.2	0	0.2	ns
t _{TPPB1}	Transmitter Output Pulse Position of Bit 1		a-0.2	a	a+0.2	ns
t _{TPPB2}	Transmitter Output Pulse Position of Bit 2		2a-0.2	2a	2a+0.2	ns
t _{TPPB3}	Transmitter Output Pulse Position of Bit 3		3a-0.2	3a	3a+0.2	ns
t _{TPPB4}	Transmitter Output Pulse Position of Bit 4		4a-0.2	4a	4a+0.2	ns
t _{TPPB5}	Transmitter Output Pulse Position of Bit 5		5a-0.2	5a	5a+0.2	ns
t _{TPPB6}	Transmitter Output Pulse Position of Bit 6		6a-0.2	6a	6a+0.2	ns
t _{JCC}	Transmitter Clock Out Jitter, Cycle-to cycle Figure 23	f=40MHz		350	370	ps
		f=65MHz		210	230	
		f=85MHz FIN1217 only		110	150	
t _{TPLLS}	Transmitter Phase Lock Loop Set Time ⁽¹³⁾	Figure 15 ⁽¹²⁾			10.0	ms

Notes:

11. Outputs of all transmitters stay in 3-STATE until power reaches 2V. Clock and data output begins to toggle 10ms after V_{CC} reaches 3V and /PwrDn pin is above 1.5V.
12. This output data pulse position works for both transmitters with 21 TTL inputs, except the LVDS output bit mapping difference (see Figure 19). Figure 20 shows the skew between the first data bit and clock output. A two-bit cycle delay is guaranteed when the MSB is output from transmitter.
13. This jitter specification is based on the assumption that PLL has a reference clock with cycle-to-cycle input jitter of less than 2ns.

Receiver DC Electrical Characteristics

Typical values are at $T_A=25^\circ\text{C}$ and with $V_{CC}=3.3\text{V}$. Positive current values refer to the current flowing into device and negative values means current flowing out of pins. Voltages are referenced to ground unless otherwise specified (except ΔV_{OD} and V_{OD}). Minimum and maximum values are at over supply voltage and operating temperature ranges unless otherwise specified.

Symbol	Parameter	Conditions	Min.	Typ.	Max.	Units	
LVTTTL/CMOS DC Characteristics							
V_{IH}	Input High Voltage		2.0		V_{CC}	V	
V_{IL}	Input Low Voltage		GND		0.8	V	
V_{OH}	Output High Voltage	$I_{OH}=-0.4\text{mA}$	2.7	3.3		V	
V_{OL}	Output Low Voltage	$I_{OL}=2\text{mA}$			0.3	V	
V_{IK}	Input Clamp Voltage	$I_{IK}=-18\text{mA}$			-1.5	V	
I_{IN}	Input Current	$V_{IN}=0\text{V to }4.6\text{V}$	-10		10	μA	
I_{OFF}	Input/Output Power-Off Leakage Current	$V_{CC}=0\text{V}$, All LVTTTL Inputs/Outputs $0\text{V to }4.6\text{V}$			± 10	μA	
I_{OS}	Output Short-Circuit Current	$V_{OUT}=0\text{V}$		-60	-120	μA	
Receiver LVDS Input Characteristics							
V_{TH}	Differential Input Threshold HIGH	Figure 6, Table 2			100	mV	
V_{TL}	Differential Input Threshold LOW	Figure 6, Table 2	-100			mV	
V_{ICM}	Input Common Mode Range	Figure 6, Table 2	0.05		2.35	V	
I_{IN}	Input Current	$V_{IN}=2.4\text{V}$, $V_{CC}=3.6\text{V}$ or 0V			± 10.0	μA	
		$V_{IN}=0\text{V}$, $V_{CC}=3.6\text{V}$ or 0V			± 10.0		
Receiver Supply Current							
I_{CCWR}	3:21 Receiver Power Supply Current for Worst Case Pattern with Load ⁽¹⁴⁾	$C_L=8\text{pF}$, Figure 7	33MHz			66	mA
			40MHz		56	74	
			65MHz		75	102	
			85MHz ⁽¹⁵⁾		92	125	
I_{CCPDR}	Powered Down Supply Current	/PwrDn=0.8V (RxOut stays LOW)		NA	400	μA	

Notes:

14. The power supply current for the receiver can be different due to the number of active I/O channels.
15. 85MHz specification for FIN1218 only.

Receiver AC Electrical Characteristics

Values are at over supply voltages and operating temperatures, unless otherwise specified.

Symbol	Parameter	Conditions	Min.	Typ.	Max.	Units
t _{RCOL}	RxCLKOut LOW Time	Figure 12 Rising Edge Strobe f=40MHz	10.0	11.0		ns
t _{RCOH}	RxCLKOut HIGH Time		10.0	12.2		ns
t _{RSRC}	RxOut Valid Prior to RxCLKOut		6.5	11.6		ns
t _{RHRC}	RxOut Valid After RxCLKOut		6.0	11.6		ns
t _{RCOP}	Receiver Clock Output (RxCLKOut) Period	Figure 12 Rising Edge Strobe f=65MHz	15.0	T	50.0	ns
t _{RCOL}	RxCLKOut LOW Time		5.0	7.8	9.0	ns
t _{RCOH}	RxCLKOut HIGH Time		5.0	7.3	9.0	ns
t _{RSRC}	RxOut Valid Prior to RxCLKOut		4.5	7.7		ns
t _{RHRC}	RxOut Valid After RxCLKOut		4.0	8.4		ns
t _{RCOP}	Receiver Clock Output (RxCLKOut) Period	Figure 12 Rising Edge Strobe f=85MHz FIN1218 only	11.76	T	50.00	ns
t _{RCOL}	RxCLKOut LOW Time		4.0	6.3	6.0	ns
t _{RCOH}	RxCLKOut HIGH Time		4.5	5.4	6.5	ns
t _{RSRC}	RxOut Valid Prior to RxCLKOut		3.5	6.3		ns
t _{RHRC}	RxOut Valid After RxCLKOut		3.5	6.5		ns
t _{ROLH}	Output Rise Time (20% to 80%)	C _L =8pF, Figure 9		2.2	5.0	ns
t _{ROHL}	Output Fall Time (80% to 20%)			2.1	5.0	ns
t _{RCCD}	Receiver Clock Input to Clock Output Delay	T _A =25°C, V _{CC} =3.3V Figure 14 ^(Error! Reference source not found.)	3.5	6.9	7.5	ns
t _{RPDD}	Receiver Power-Down Delay	Figure 18			1.0	ms
t _{RSPB0}	Receiver Input Strobe Position of Bit 0	Figure 21 f=40MHz	1.00		2.15	ns
t _{RSPB1}	Receiver Input Strobe Position of Bit 1		4.5		5.8	ns
t _{RSPB2}	Receiver Input Strobe Position of Bit 2		8.10		9.15	ns
t _{RSPB3}	Receiver Input Strobe Position of Bit 3		11.6		12.6	ns
t _{RSPB4}	Receiver Input Strobe Position of Bit 4		15.1		16.3	ns
t _{RSPB5}	Receiver Input Strobe Position of Bit 5		18.8		19.9	ns
t _{RSPB6}	Receiver Input Strobe Position of Bit 6		22.5		23.6	ns

Continued on following page...



Receiver AC Electrical Characteristics (Continued)

Symbol	Parameter	Conditions	Min.	Typ.	Max.	Units
t _{RSPB0}	Receiver Input Strobe Position of Bit 0	Figure 21 f=65MHz	0.7		1.4	ns
t _{RSPB1}	Receiver Input Strobe Position of Bit 1		2.9		3.6	ns
t _{RSPB2}	Receiver Input Strobe Position of Bit 2		5.1		5.8	ns
t _{RSPB3}	Receiver Input Strobe Position of Bit 3		7.3		8.0	ns
t _{RSPB4}	Receiver Input Strobe Position of Bit 4		9.5		10.2	ns
t _{RSPB5}	Receiver Input Strobe Position of Bit 5		11.7		12.4	ns
t _{RSPB6}	Receiver Input Strobe Position of Bit 6		13.9		14.6	ns
t _{RSPB0}	Receiver Input Strobe Position of Bit 0	Figure 21 f=85MHz FIN1218 only	0.49		1.19	ns
t _{RSPB1}	Receiver Input Strobe Position of Bit 1		2.17		2.87	ns
t _{RSPB2}	Receiver Input Strobe Position of Bit 2		3.85		4.55	ns
t _{RSPB3}	Receiver Input Strobe Position of Bit 3		5.53		6.23	ns
t _{RSPB4}	Receiver Input Strobe Position of Bit 4		7.21		7.91	ns
t _{RSPB5}	Receiver Input Strobe Position of Bit 5		8.89		9.59	ns
t _{RSPB6}	Receiver Input Strobe Position of Bit 6		10.57		11.27	ns
t _{RSKM}	RxIn Skew Margin ^(Error! Reference source not found.)	f=40MHz, Figure 22	490			ps
		f=65MHz, Figure 22	400			
		f=85MHz FIN1218 only Figure 22	252			
t _{RPLLS}	Receiver Phase Lock Loop Set Time	Figure 16			10.0	ms

Notes:

16. Total channel latency from serializer to deserializer is $(T + t_{RCCD}) + (2 \cdot T + t_{RCCD})$.
17. Receiver skew margin is defined as the valid sampling window after considering potential setup/hold time and minimum/maximum bit position.

Test Circuits

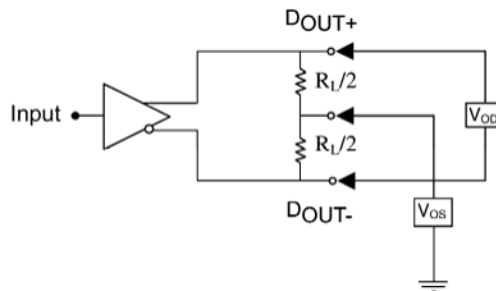
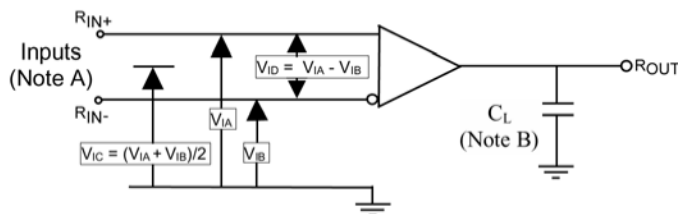

Figure 5. Differential LVDS Output DC Test Circuit



Notes: For all input pulses, t_R or $t_F \leq 1\text{ns}$.
 C_L includes all probe and jig capacitance.

Figure 6. Differential Receiver Voltage Definitions, Propagation Delay, and Transition Time Test Circuit

Table 2. Receiver Minimum and Maximum Input Threshold Test Voltages

Applied Voltages (V)		Resulting Differential Input Voltage (mV)	Resulting Common Mode Input Voltage (V)
V_{IA}	V_{IB}	V_{ID}	V_{IC}
1.25	1.15	100	1.20
1.15	1.25	-100	1.20
2.40	2.30	100	2.35
2.30	2.40	-100	2.35
0.10	0	100	0.05
0	0.10	-100	0.05
1.50	0.90	600	1.20
0.90	1.50	-600	1.20
2.40	1.80	600	2.10
1.80	2.40	-600	2.10
0.60	0	600	0.30
0	0.60	-600	0.30

AC Loadings and Waveforms

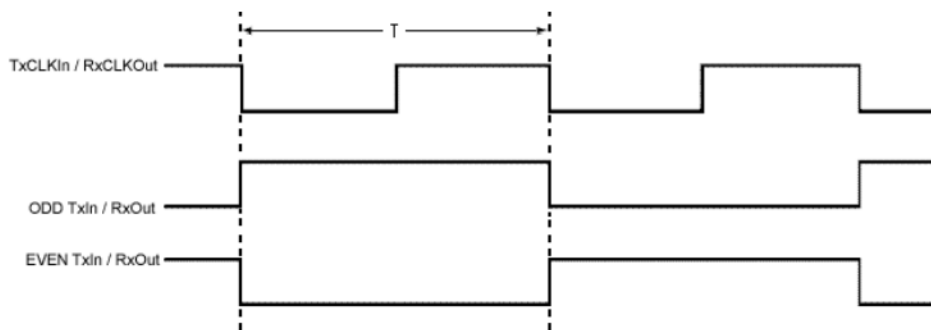

Note: The worst-case test pattern produces a maximum toggling of digital circuits, LVDS I/O and LVTTL/CMOS I/O. Depending on the valid strobe edge of transmitter, the TxCLKIn can be either rising or falling edge data strobe.

Figure 7. Worst-Case Test Pattern

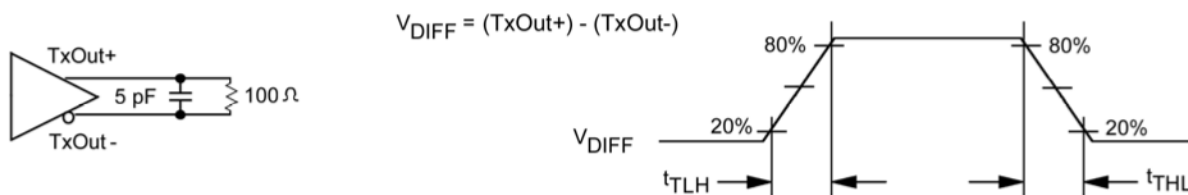

Figure 8. Transmitter LVDS Output Load and Transition Times



Figure 9. Receiver LVTTL/CMOS Output Load and Transition Times

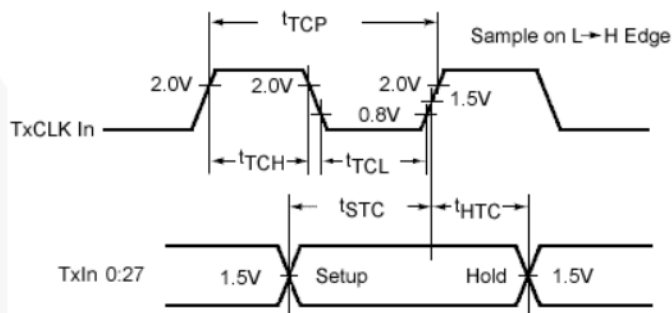

Figure 10. Transmitter Set-up/Hold and HIGH/LOW Times (Rising Edge Strobe)

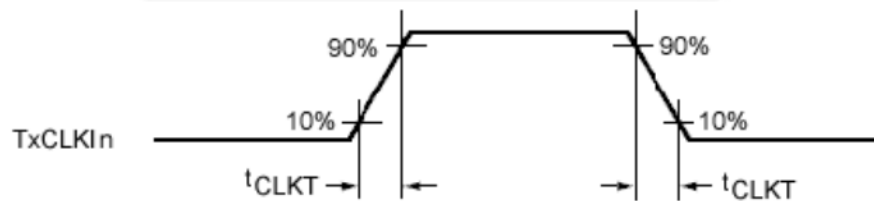

Figure 11. Transmitter Input Clock Transition Time

AC Loadings and Waveforms (Continued)

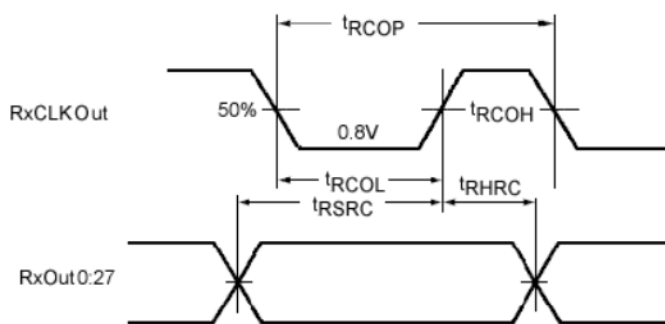

Figure 12. Receiver Set-up/Hold and HIGH/LOW Times



Figure 13. Transmitter Clock-In to Clock-Out Delay (Rising Edge Strobe)

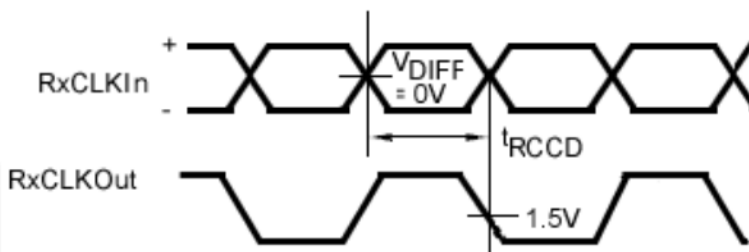

Figure 14. Receiver Clock-In to Clock-Out Delay (Rising Edge Strobe)

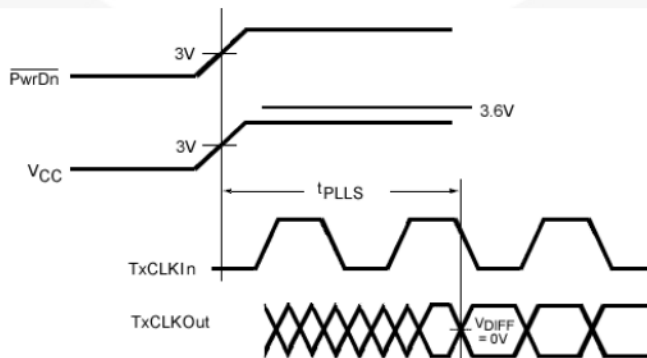

Figure 15. Transmitter Phase-Lock-Loop Set Time

AC Loadings and Waveforms (Continued)

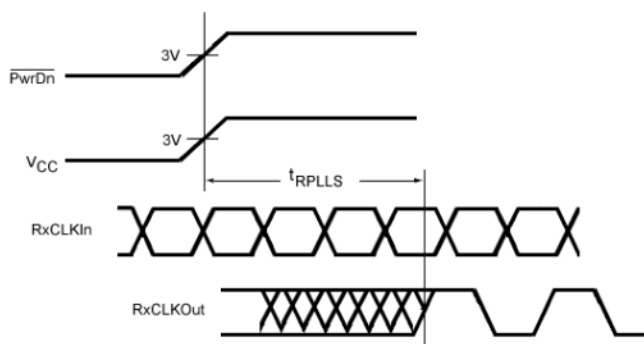

Figure 16. Receiver Phase Lock Loop Set Time

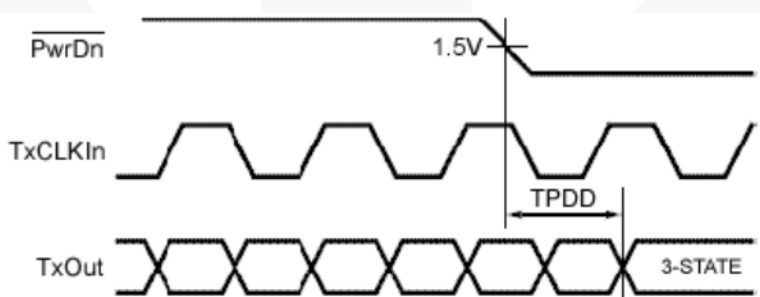

Figure 17. Transmitter Power-down Delay

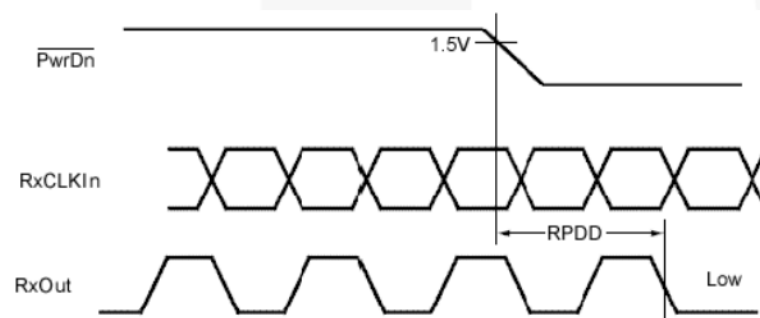
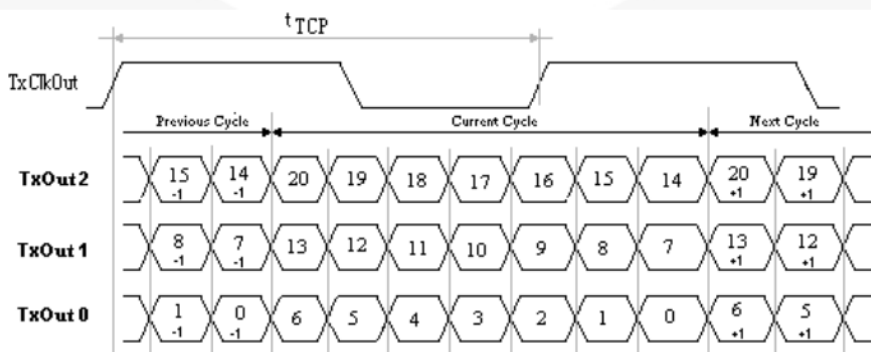

Figure 18. Receiver Power-down Delay



Note: This output data pulse position works for both transmitters with 21 TTL inputs, except the LVDS output bit mapping difference. Two-bit cycle delay is guaranteed with the MSB is output from transmitter.

Figure 19. Parallel LVTTL Inputs Mapped to Three Serial LVDS Outputs

AC Loadings and Waveforms (Continued)

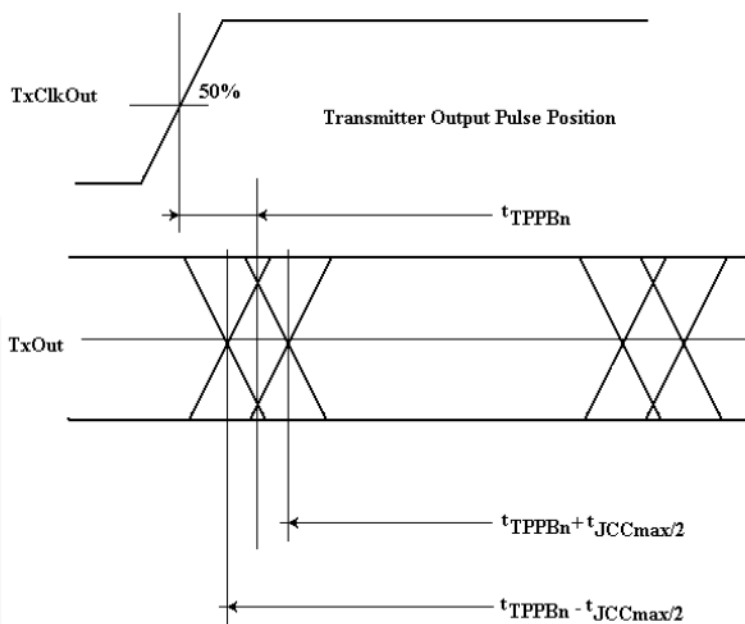

Figure 20. Transmitter Output Pulse Bit Position

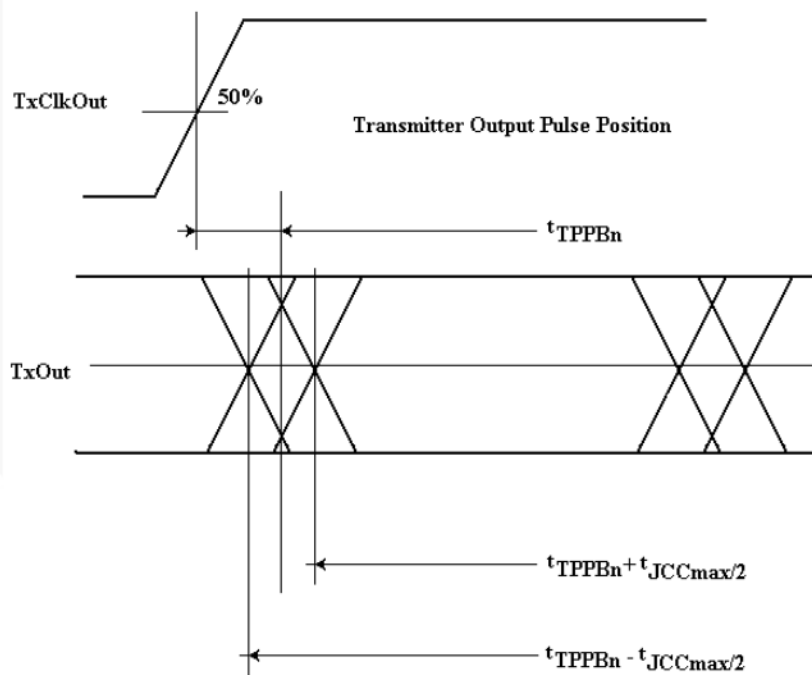
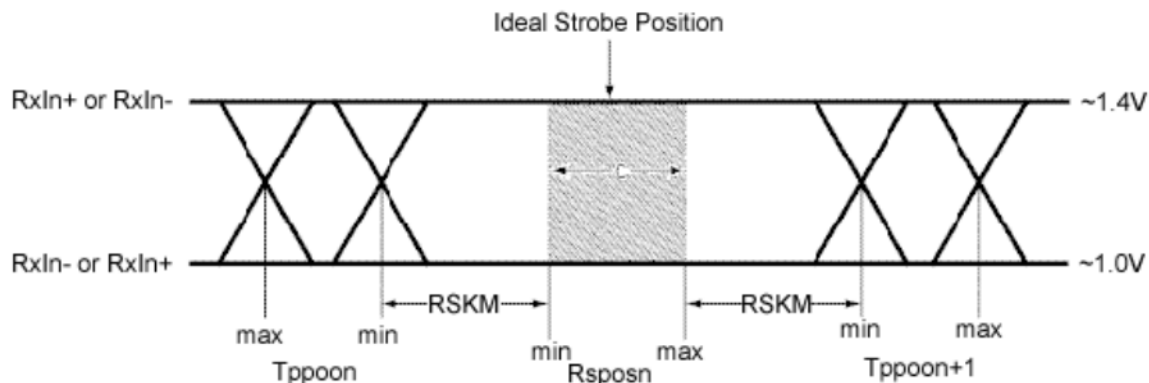

Figure 21. Receiver Strobe Bit Position

AC Loadings and Waveforms (Continued)



Note: t_{RSKM} is the budget for the cable skew and source clock skew plus Inter-Symbol Interference (ISI). The minimum and maximum pulse position values are based on the bit position of each of the seven bits within the LVDS data stream across PVT (Process, Voltage Supply, and Temperature).

Figure 22. Receiver LVDS Input Skew Margin

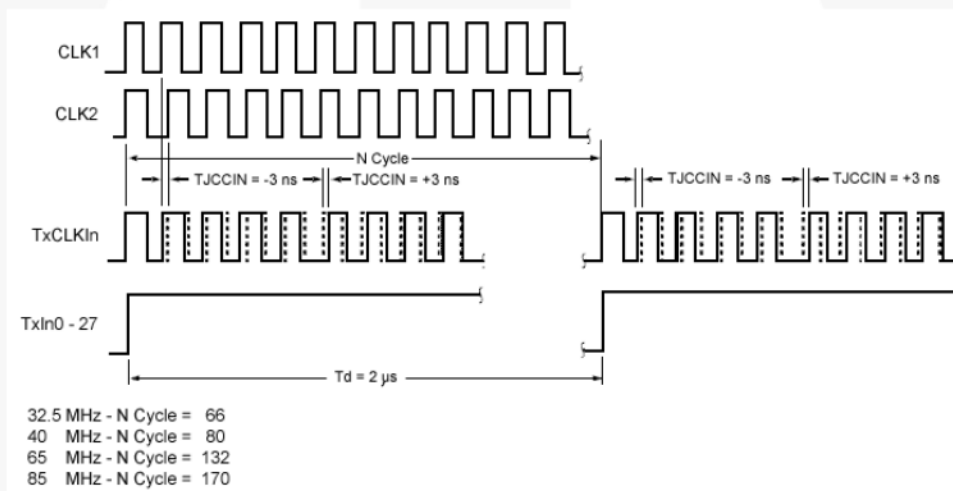

Note: This jitter pattern is used to test the jitter response (clock out) of the device over the power supply range with worst jitter ± 3 ns (cycle-to-cycle) clock input. The specific test methodology is as follows:

- Switching input data TxIn0 to TxIn20 at 0.5MHz and the input clock is shifted to left -3ns and to the right +3ns when data is HIGH (by switching between CLK1 and CLK2 in Figure 11).
- The ± 3 ns cycle-to-cycle input jitter is the static phase error between the two clock sources. Jumping between two clock sources to simulate the worst-case of clock edge jump (3ns) from graphical controllers. Cycle-to-cycle jitter at TxCLK out pin should be measured cross V_{CC} range with 100mV noise (V_{CC} noise frequency < 2 MHz).

Figure 23. Jitter Pattern

Physical Dimensions

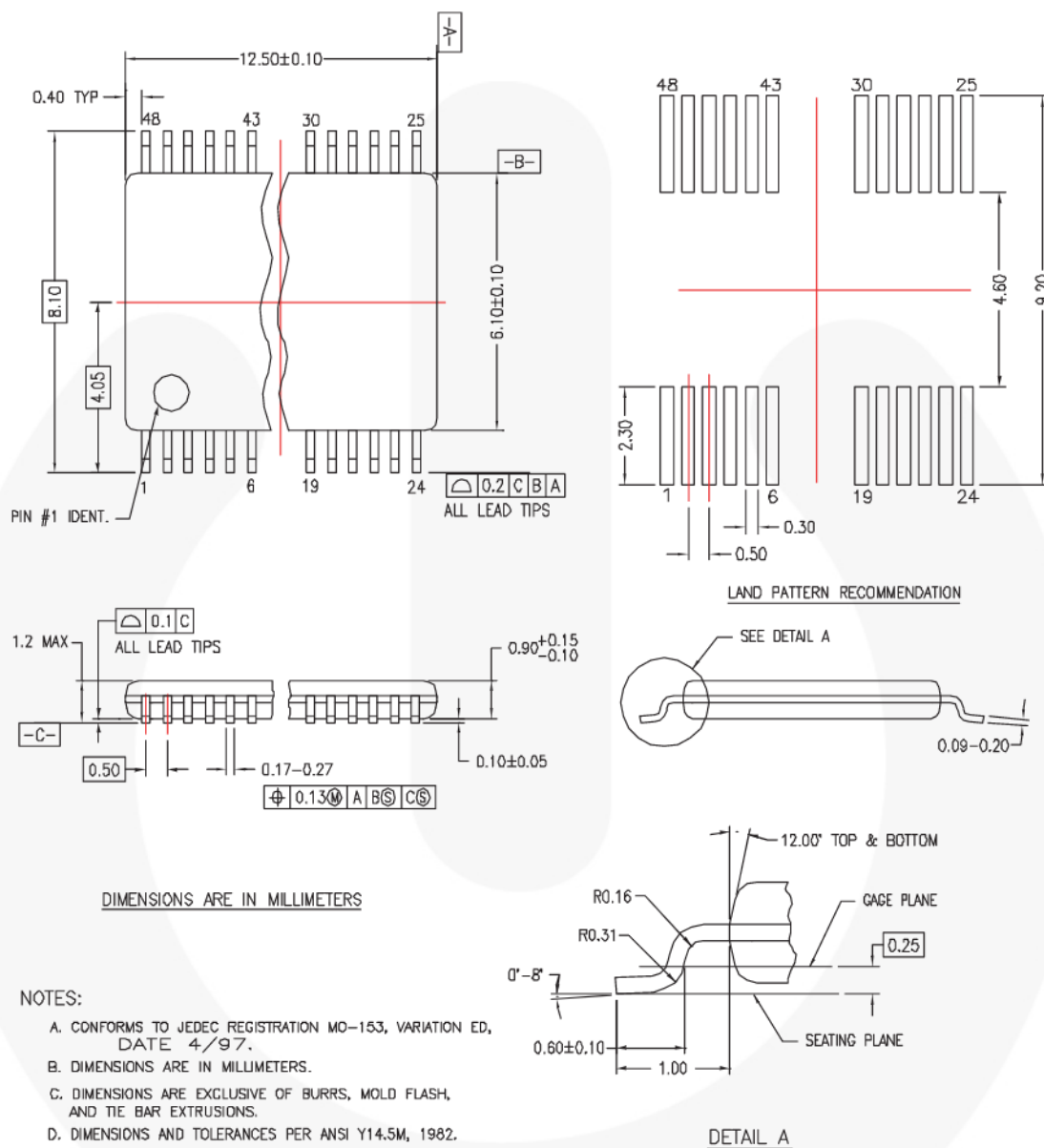

MTD48REVC

Figure 24. 48-Lead Thin Shrink Small Outline Package (TSSOP)

Package drawings are provided as a service to customers considering Fairchild components. Drawings may change in any manner without notice. Please note the revision and/or date on the drawing and contact a Fairchild Semiconductor representative to verify or obtain the most recent revision. Package specifications do not expand the terms of Fairchild's worldwide terms and conditions, specifically the warranty therein, which covers Fairchild products.

Always visit Fairchild Semiconductor's online packaging area for the most recent package drawings:
<http://www.fairchildsemi.com/packaging/>



TRADEMARKS

The following includes registered and unregistered trademarks and service marks, owned by Fairchild Semiconductor and/or its global subsidiaries, and is not intended to be an exhaustive list of all such trademarks.

AccuPower™
Auto-SPM™
Build it Now™
CorePLUS™
CorePOWER™
CROSSVOL7™
CTL™
Current Transfer Logic™
EcoSPARK®
EfficientMax™
EZSWITCH™
EZ™
DEUXPEED™
F®
Fairchild®
Fairchild Semiconductor®
FACT Quiet Series™
FACT®
FAST®
FastCore™
FETBench™

FlashWriter®
FPS™
F-PFS™
FRFET®
Global Power Resource™
Green FPST™
Green FPST™ e-Series™
Gmax™
GTO™
IntelliMAX™
ISOPLANAR™
MegaBuck™
MICROCOUPLER™
MicroFET™
MicroPak™
MillerDrive™
MotionMax™
Motion-SPM™
OPTOLOGIC®
OPTOPLANAR®
PDP SPM™

Power-SPM™
PowerTrench®
PowerXS™
Programmable Active Droop™
QFET®
QS™
Quiet Series™
RapidConfigure™
Saving our world, 1mW/W/kW at a time™
SignalWise™
SmartMax™
SMART START™
SPM®
STEALTH™
SuperFET™
SuperSOT™-3
SuperSOT™-6
SuperSOT™-8
SupreMOS™
SyncFET™
Sync-Lock™

SYSTEM GENERAL®
The Power Franchise®
the power franchise
TinyBoost™
TinyBuck™
TinyCalc™
TinyLogic®
TINYOPTO™
TinyPower™
TinyPWM™
TinyWire™
TriFault Detect™
TRUECURRENT™
µSerDes™
SerDes®
UHC®
Ultra FRFET™
UniFET™
VCX™
VisualMax™
XS™

* Trademarks of System General Corporation, used under license by Fairchild Semiconductor.

DISCLAIMER

FAIRCHILD SEMICONDUCTOR RESERVES THE RIGHT TO MAKE CHANGES WITHOUT FURTHER NOTICE TO ANY PRODUCTS HEREIN TO IMPROVE RELIABILITY, FUNCTION, OR DESIGN. FAIRCHILD DOES NOT ASSUME ANY LIABILITY ARISING OUT OF THE APPLICATION OR USE OF ANY PRODUCT OR CIRCUIT DESCRIBED HEREIN; NEITHER DOES IT CONVEY ANY LICENSE UNDER ITS PATENT RIGHTS, NOR THE RIGHTS OF OTHERS. THESE SPECIFICATIONS DO NOT EXPAND THE TERMS OF FAIRCHILD'S WORLDWIDE TERMS AND CONDITIONS, SPECIFICALLY THE WARRANTY THEREIN, WHICH COVERS THESE PRODUCTS.

LIFE SUPPORT POLICY

FAIRCHILD'S PRODUCTS ARE NOT AUTHORIZED FOR USE AS CRITICAL COMPONENTS IN LIFE SUPPORT DEVICES OR SYSTEMS WITHOUT THE EXPRESS WRITTEN APPROVAL OF FAIRCHILD SEMICONDUCTOR CORPORATION.

As used herein:

1. Life support devices or systems are devices or systems which, (a) are intended for surgical implant into the body or (b) support or sustain life, and (c) whose failure to perform when properly used in accordance with instructions for use provided in the labeling, can be reasonably expected to result in a significant injury of the user.
2. A critical component in any component of a life support, device, or system whose failure to perform can be reasonably expected to cause the failure of the life support device or system, or to affect its safety or effectiveness.

ANTI-COUNTERFEITING POLICY

Fairchild Semiconductor Corporation's Anti-Counterfeiting Policy. Fairchild's Anti-Counterfeiting Policy is also stated on our external website, www.fairchildsemi.com, under Sales Support.

Counterfeiting of semiconductor parts is a growing problem in the industry. All manufacturers of semiconductor products are experiencing counterfeiting of their parts. Customers who inadvertently purchase counterfeit parts experience many problems such as loss of brand reputation, substandard performance, failed applications, and increased cost of production and manufacturing delays. Fairchild is taking strong measures to protect ourselves and our customers from the proliferation of counterfeit parts. Fairchild strongly encourages customers to purchase Fairchild parts either directly from Fairchild or from Authorized Fairchild Distributors who are listed by country on our web page cited above. Products customers buy either from Fairchild directly or from Authorized Fairchild Distributors are genuine parts, have full traceability, meet Fairchild's quality standards for handling and storage and provide access to Fairchild's full range of up-to-date technical and product information. Fairchild and our Authorized Distributors will stand behind all warranties and will appropriately address any warranty issues that may arise. Fairchild will not provide any warranty coverage or other assistance for parts bought from Unauthorized Sources. Fairchild is committed to combat this global problem and encourage our customers to do their part in stopping this practice by buying direct or from authorized distributors.

PRODUCT STATUS DEFINITIONS

Definition of Terms

Datasheet Identification	Product Status	Definition
Advance Information	Formative / In Design	Datasheet contains the design specifications for product development. Specifications may change in any manner without notice.
Preliminary	First Production	Datasheet contains preliminary data; supplementary data will be published at a later date. Fairchild Semiconductor reserves the right to make changes at any time without notice to improve design.
No Identification Needed	Full Production	Datasheet contains final specifications. Fairchild Semiconductor reserves the right to make changes at any time without notice to improve the design.
Obsolete	Not In Production	Datasheet contains specifications on a product that is discontinued by Fairchild Semiconductor. The datasheet is for reference information only.

Rev. I43