

D2576HV

3A Step-Down HV Voltage Regulator

General Description

The D2576HV series of regulators are monolithic integrated circuit that provides all the active functions for a step-down (buck) switching regulator, capable of driving 3A load with excellent line and load regulation. The D2576HV available in fixed output voltages of 3.3V, 5V, 12V and an adjustable output version.

Requiring a minimum number of external components, these regulators are simple to use and include internal frequency compensation and a fixed-frequency oscillator.

The D2576HV series offers a high-efficiency replacement for popular three-terminal linear regulators. It substantially reduces the size of the heat sink, and in some cases no heat sink is required. A standard series of inductors optimized for use with the D2576HV are available from several different manufacturers. This feature greatly simplifies the design of switch-mode power supplies.

Other features include a guaranteed $\pm 4\%$ tolerance on output voltage within specified input voltages and output load conditions, and $\pm 10\%$ on the oscillator frequency. External shutdown is included, featuring 50 μA (typical) standby current. The output switch includes cycle-by-cycle current limiting, as well as thermal shutdown for full protection under fault conditions.

The D2576HV is available in TO220T-5L and TO263-5L package.

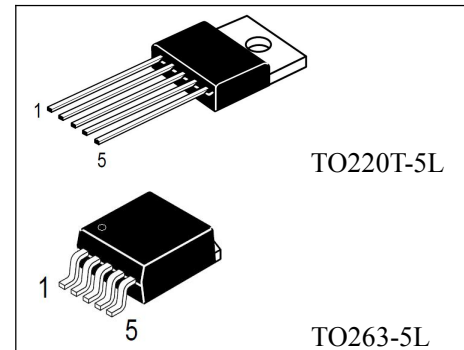

Features

- 3.3V, 5V, 12V and adjustable output versions
- Wide input voltage range, 40V up to 60V for HV version
- High efficiency
- Specified 3A output current
- 52 kHz fixed frequency internal oscillator
- TTL shutdown capability, low power standby mode
- Uses readily available standard inductors
- Thermal shutdown and current limit protection
- Adjustable version output voltage range, 1.23V to 57V $\pm 4\%$ max over line and load conditions

Applications

- Simple high-efficiency step-down (Buck) regulator
- Efficient pre-regulator for linear regulators
- On-card switching regulators
- Positive to negative converter (Buck-Boost)

Functional Block Diagram

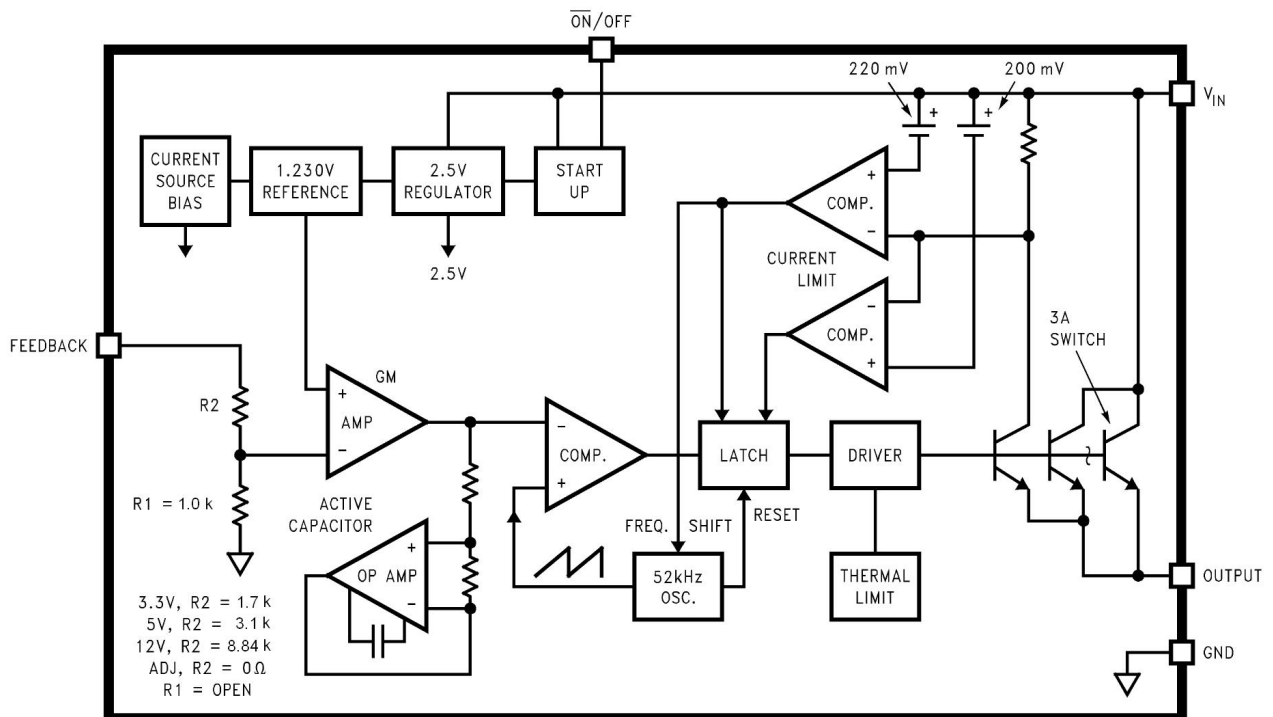

Pin Configuration

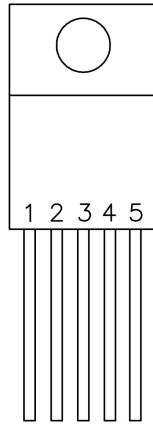

TO220T-5L

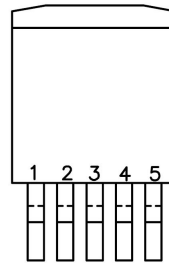

TO263-5L

Pin Description

Pin Number	Pin Name	Function Description
1	V _{IN}	This is the positive input supply for the IC switching regulator. A suitable input bypass capacitor must be present at this pin to minimize voltage transients and to supply the switching currents needed by the regulator.
2	OUTPUT	Internal switch, the voltage at this pin switches between (+V _{IN} V _{SAT}) and approximately -0.5V. To minimize coupling to sensitive circuitry, the PC board copper area connected to this pin should be kept to a minimum.
3	GND	Circuit Ground
4	FEEDBACK	Senses the regulated output voltage to complete the feedback loop.
5	\overline{ON} / OFF	Allows the switching regulator circuit to be shut down using logic level signals

Absolute Maximum Ratings

Parameter Name	Symbol	Value	Unit
Maximum Supply Voltage	V _{IN}	63	V
\overline{ON} / OFF Pin Input Voltage	\overline{ON} / OFF	-0.3V ≤ V ≤ +V _{IN}	V
Output Voltage to Ground(steady state)	V _{OUT}	-1	V
Power Dissipation	P _{DMAX}	Internally Limited	
Storage Temperature Range	T _{stg}	-65~+150	°C
Maximum Junction Temperature	T _{JA}	150	°C
ESD Susceptibility (Human Body Model)	ESD	2	kV
Lead Temperature (Soldering, 10 Seconds)	T _L	260	°C

Recommended Operating Conditions

Parameter Name	Symbol	Value	Unit
Supply Voltage	V_{IN}	6~60	V
Operating temperature range	T_{opr}	-40~+125	°C

Electrical Characteristics

(Unless otherwise specified: $T_J = 25^{\circ}\text{C}$)

Parameter Name	Symbol	Test Conditions	Min	Typ	Max	Units
Device Parameters						
Feedback Bias Current	I_b	Adjustable version only, $V_{OUT}=5V$		50	100	nA
Oscillator Frequency	f_o	(Note 1)	47	52	58	kHz
V_{SAT} Saturation Voltage	V_{SAT}	$I_{OUT}=3A$		1.4	1.8	V
Max. Duty Cycle(ON)	DC		93	98		%
Current Limit	I_{CL}	(Note 1)	4.2	5.8	6.9	A
Output Leakage Current	I_L	Output=0V			2	mA
		Output=-1V		7.5	30	mA
Quiescent Current	I_Q			5	10	mA
Standby Quiescent Current	I_{STBY}	\overline{ON}/OFF pin=5V(OFF)		50	200	μA
\overline{ON}/OFF Control						
\overline{ON}/OFF Pin Logic Input Level	V_{IH}	$V_{OUT}=0V$	2.0			V
	V_{IL}	$V_{OUT}=\text{nominal output voltage}$			0.8	V
\overline{ON}/OFF Pin Input Current	I_{IH}	\overline{ON}/OFF pin=5V(OFF)		12	30	μA
	I_{IL}	\overline{ON}/OFF pin=0V(ON)		0	10	μA

Note 1: The oscillator frequency reduces to approximately 11 kHz in the event of an output short or an overload which causes the regulated output voltage to drop approximately 40% from the nominal output voltage. This self protection feature lowers the average power dissipation of the IC by lowering the minimum duty cycle from 5% down to approximately 2%.

Output pin sourcing current. No diode, inductor or capacitor connected to output.

D2576HV

Parameter Name	Symbol	Test Conditions	Min	Typ	Max	Units
D2576HV-3.3V						
Output Voltage	V_{OUT}	$V_{IN}=12V, I_O=500mA$	3.234	3.3	3.366	V
		$6V \leq V_{IN} \leq 60V$ $0.5A \leq I_{LOAD} \leq 3A$	3.168	3.3	3.450	V
Efficiency	η	$V_{IN}=12V, I_{LOAD}=3A$		75		%
D2576HV-5.0V						
Output Voltage	V_{OUT}	$V_{IN}=12V, I_O=500mA$	4.90	5.00	5.10	V
		$8V \leq V_{IN} \leq 60V$ $0.5A \leq I_{LOAD} \leq 3A$	4.800	5.0	5.225	V
Efficiency	η	$V_{IN}=12V, I_{LOAD}=3A$		77		%
D2576HV-12V						
Output Voltage	V_{OUT}	$V_{IN}=25V, I_O=500mA$	11.76	12.00	12.24	V
		$15V \leq V_{IN} \leq 60V$ $0.5A \leq I_{LOAD} \leq 3A$	11.52	12.00	12.54	V
Efficiency	η	$V_{IN}=25V, I_{LOAD}=3A$		88		%

Parameter Name	Symbol	Test Conditions	Min	Typ	Max	Units
D2576HV-ADJ						
Output Voltage	V_{OUT}	$V_{IN}=12V, I_O=500mA,$ $V_{OUT}=5V$	1.217	1.230	1.243	V
		$8V \leq V_{IN} \leq 60V, V_{OUT}=5V$ $0.5A \leq I_{LOAD} \leq 3A$	1.193	1.230	1.273	V
Efficiency	η	$V_{IN}=12V, I_{LOAD}=3A,$ $V_{OUT}=5V$		77		%

Test Circuit

Fixed Output Voltage Versions

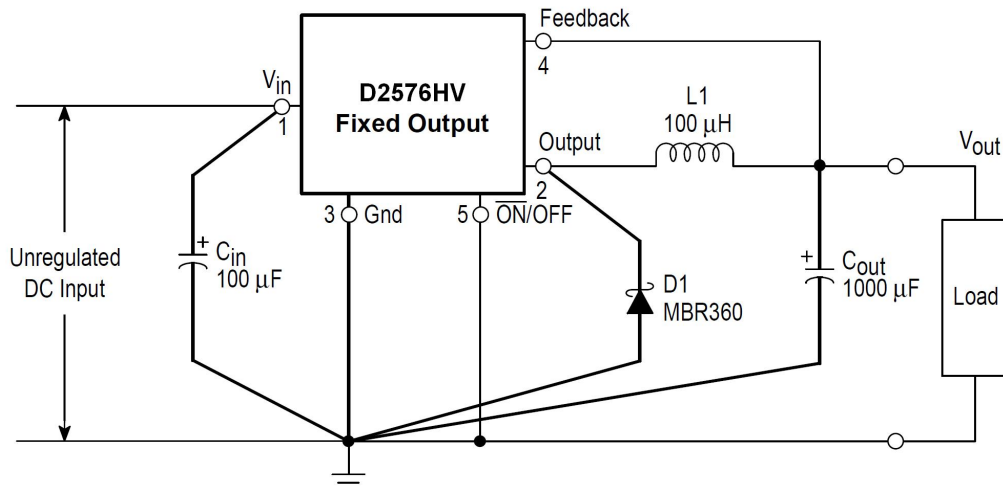

- C_{in} - 100 μ F, 100 V, Aluminium Electrolytic
- C_{out} - 1000 μ F, 25 V, Aluminium Electrolytic
- D1 - Schottky, MBR360
- L1 - 100 μ H, Pulse Eng. PE-92108
- R1 - 2.0 k, 0.1%
- R2 - 6.12 k, 0.1%

Adjustable Output Voltage Versions

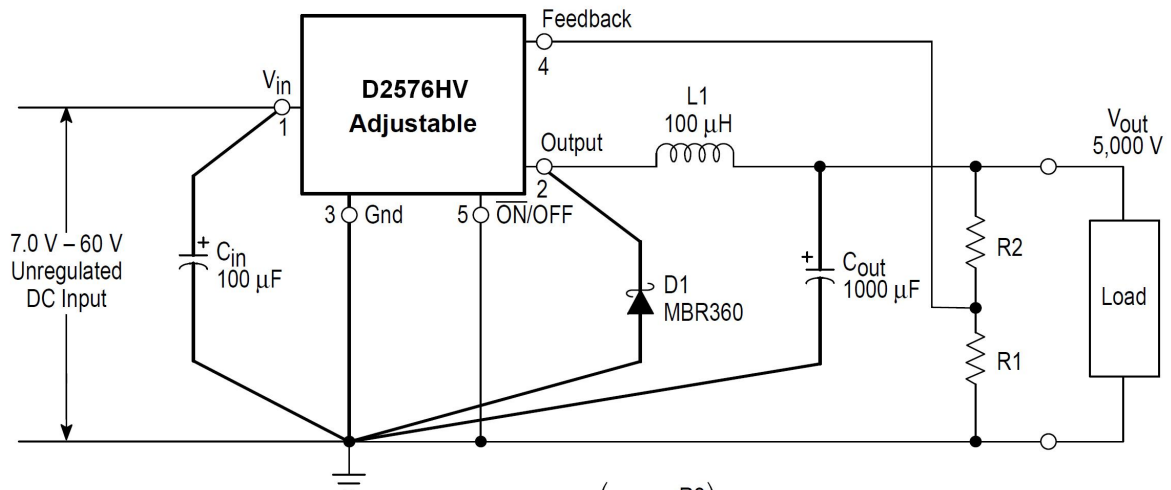

$$V_{out} = V_{ref} \left(1.0 + \frac{R2}{R1} \right)$$

$$R2 = R1 \left(\frac{V_{out}}{V_{ref}} - 1.0 \right)$$

Where $V_{ref} = 1.23$ V, R1
between 1.0 k and 5.0 k

Typical Application

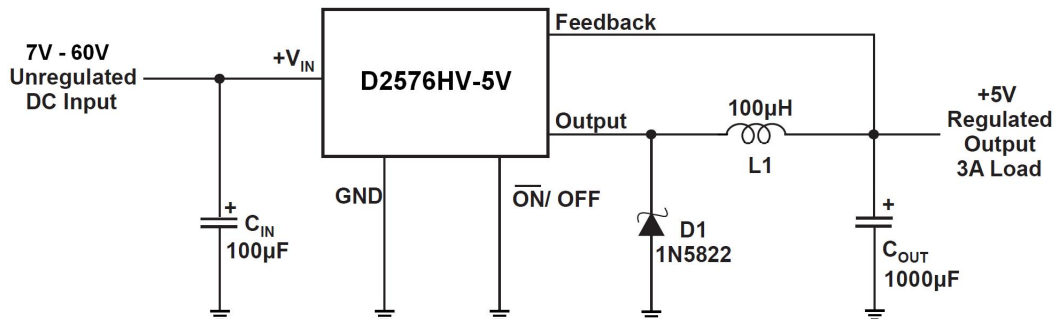

Application Information

Input Capacitor (C_{IN})

To maintain stability, the regulator input pin must be bypassed with at least a 100 μ F electrolytic capacitor. The capacitor's leads must be kept short, and located near the regulator. If the operating temperature range includes temperatures below -25°C , the input capacitor value may need to be larger. With most electrolytic capacitors, the capacitance value decreases and the ESR increases with lower temperatures and age. Paralleling a ceramic or solid tantalum capacitor will increase the regulator stability at cold temperatures. For maximum capacitor operating lifetime, the capacitor's RMS ripple current rating should be greater than

$$1.2 \times \left(\frac{t_{ON}}{T} \right) \times I_{LOAD}$$

Where $\frac{t_{ON}}{T} = \frac{V_{OUT}}{V_{IN}}$ for a buck regulator

and $\frac{t_{ON}}{T} = \frac{|V_{OUT}|}{|V_{OUT}| + V_{IN}}$ for a buck-boost regulator.

Inductor Selection

All switching regulators have two basic modes of operation: continuous and discontinuous. The difference between the two types relates to the inductor current, whether it is flowing continuously, or if it drops to zero for a period of time in the normal switching cycle. Each mode has distinctively different operating characteristics, which can affect the regulator performance and requirements. The D2576HV can be used for both continuous and discontinuous modes of operation. When using inductor values shown in the inductor selection guide, the peak-to-peak inductor ripple current will be approximately 20% to 30% of the maximum DC current. With relatively heavy load currents, the circuit operates in the continuous mode (inductor current always flowing), but under light load conditions, the circuit will be forced to the discontinuous mode (inductor current falls to zero

for a period of time). This discontinuous mode of operation is perfectly acceptable. For light loads (less than approximately 300mA) it may be desirable to operate the regulator in the discontinuous mode, primarily because of the lower inductor values required for the discontinuous mode. The selection guide chooses inductor values suitable for continuous mode operation, but if the inductor value chosen is prohibitively high, the designer should investigate the possibility of discontinuous operation.

Inductors are available in different styles such as pot core, toroid, E-frame, bobbin core, etc., as well as different core materials, such as ferrites and powdered iron. The least expensive, the bobbin core type, consists of wire wrapped on a ferrite rod core. This type of construction makes for an inexpensive inductor, but since the magnetic flux is not completely contained within the core, it generates more electromagnetic interference (EMI). This EMI can cause problems in sensitive circuits, or can give incorrect scope readings because of induced voltages in the scope probe. The inductors listed in the selection chart include ferrite pot core construction for AIE, powdered iron toroid for Pulse Engineering, and ferrite bobbin core for Renco.

An inductor should not be operated beyond its maximum rated current because it may saturate. When an inductor begins to saturate, the inductance decreases rapidly and the inductor begins to look mainly resistive (the DC resistance of the winding). This will cause the switch current to rise very rapidly. Different inductor types have different saturation characteristics, and this should be kept in mind when selecting an inductor.

The inductor manufacturer's data sheets include current and energy limits to avoid inductor saturation.

Inductor Ripple Current

When the switcher is operating in the continuous mode, the inductor current waveform ranges from a triangular to a sawtooth type of waveform (depending on the input voltage). For a given input voltage and output voltage, the peak-to-peak amplitude of this inductor current waveform remains constant. As the load current rises or falls, the entire sawtooth current waveform also rises or falls. The average DC value of this waveform is equal to the DC load current (in the buck regulator configuration). If the load current drops to a low enough level, the bottom of the sawtooth current waveform will reach zero, and the switcher will change to a discontinuous mode of operation. This is a perfectly acceptable mode of operation. Any buck switching regulator (no matter how large the inductor value is) will be forced to run discontinuous if the load current is light enough.

Catch Diode

Buck regulators require a diode to provide a return path for the inductor current when the switch is off. This diode should be located close to the D2576HV using short leads and short printed circuit traces. Because of their fast switching speed and low forward voltage drop, Schottky diodes provide the best efficiency, especially in low output voltage switching regulators (less than 5V). Fast-Recovery, High-Efficiency, or Ultra-Fast Recovery diodes are also suitable, but some types with an abrupt turn-off characteristic may cause instability and EMI

problems. A fast-recovery diode with soft recovery characteristics is a better choice. Standard 60 Hz diodes (e.g., 1N4001 or 1N5400, etc.) are also not suitable.

Output Capacitor

An output capacitor is required to filter the output voltage and is needed for loop stability. The capacitor should be located near the D2576HV using short pc board traces. Standard aluminum electrolytics are usually adequate, but low ESR types are recommended for low output ripple voltage and good stability. The ESR of a capacitor depends on many factors, some which are: the value, the voltage rating, physical size and the type of construction. In general, low value or low voltage (less than 12V) electrolytic capacitors usually have higher ESR numbers.

The amount of output ripple voltage is primarily a function of the ESR (Equivalent Series Resistance) of the output capacitor and the amplitude of the inductor ripple current (ΔI_{IND}). See the section on inductor ripple current in Application Hints. The lower capacitor values (220 μ F–1000 μ F) will allow typically 50 mV to 150 mV of output ripple voltage, while larger-value capacitors will reduce the ripple to approximately 20 mV to 50 mV. Output Ripple Voltage = (ΔI_{IND}) (ESR of C_{OUT}). To further reduce the output ripple voltage, several standard electrolytic capacitors may be paralleled, or a higher-grade capacitor may be used. Such capacitors are often called “high-frequency” “low-inductance” or “low-ESR” These will reduce the output ripple to 10 mV or 20 mV. However, when operating in the continuous mode, reducing the ESR below 0.03 Ω can cause instability in the regulator. Tantalum capacitors can have a very low ESR, and should be carefully evaluated if it is the only output capacitor. Because of their good low temperature characteristics, a tantalum can be used in parallel with aluminum electrolytics, with the tantalum making up 10% or 20% of the total capacitance. The capacitor’s ripple current rating at 52 kHz should be at least 50% higher than the peak-to-peak inductor ripple current.

Output Voltage Ripple and Transients

The output voltage of a switching power supply will contain a sawtooth ripple voltage at the switcher frequency, typically about 1% of the output voltage, and may also contain short voltage spikes at the peaks of the sawtooth waveform. The output ripple voltage is due mainly to the inductor sawtooth ripple current multiplied by the ESR of the output capacitor. The voltage spikes are present because of the fast switching action of the output switch, and the parasitic inductance of the output filter capacitor. To minimize these voltage spikes, special low inductance capacitors can be used, and their lead lengths must be kept short. Wiring inductance, stray capacitance, as well as the scope probe used to evaluate these transients, all contribute to the amplitude of these spikes. An additional small LC filter (20 μ H & 100 μ F) can be added to the output to further reduce the amount of output ripple and transients. A 10 \times reduction in output ripple voltage and transients is possible with this filter.

Feedback Connection

The D2576HV (fixed voltage versions) feedback pin must be wired to the output voltage point of the switching power supply. When using the adjustable version, physically locate both output voltage programming resistors near the D2576HV to avoid picking up unwanted noise. Avoid using resistors greater than 100kΩ because of the increased chance of noise pickup.

\overline{ON}/OFF Input

For normal operation, the \overline{ON}/OFF pin should be grounded or driven with a low-level TTL voltage (typically below 1.6V). To put the regulator into standby mode, drive this pin with a high-level TTL or CMOS signal. The \overline{ON}/OFF pin can be safely pulled up to +V_{IN} without a resistor in series with it. The \overline{ON}/OFF pin should not be left open.

Inductor Value Selection Guides (For Continuous Mode Operation)

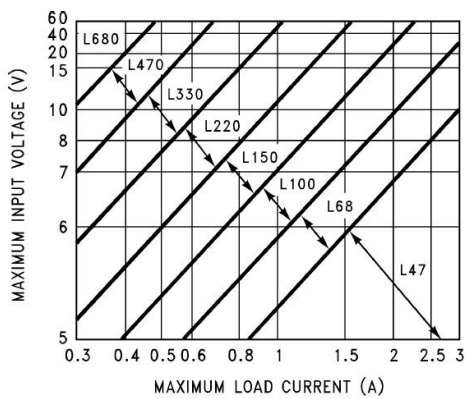

D2576HV-3.3

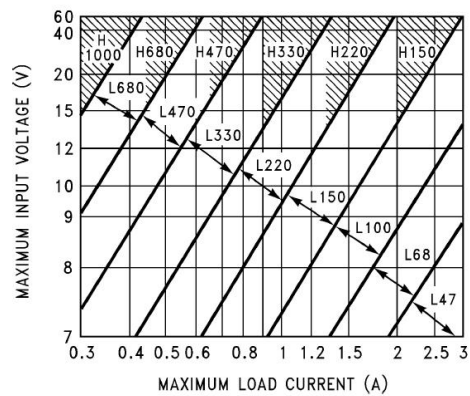

D2576HV-5.0

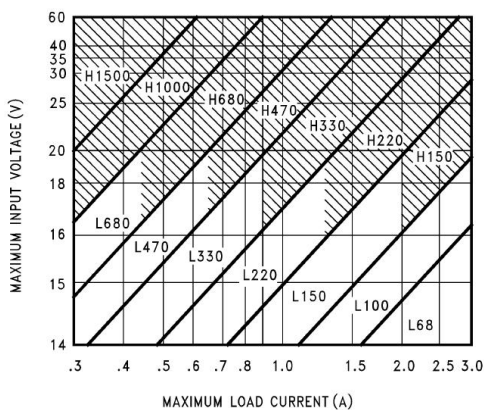

D2576HV-12

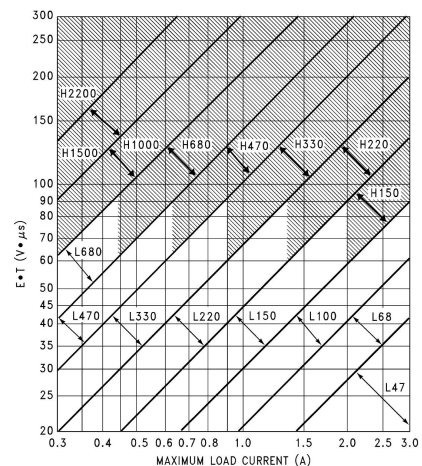

D2576HV-ADJ

Inductor Code	Inductor Value	Schott	Pulse Eng.	Renco
L47	47 μ H	671 26980	PE-53112	RL2442
L68	68 μ H	671 26990	PE-92114	RL2443
L100	100 μ H	671 27000	PE-92108	RL2444
L150	150 μ H	671 27010	PE-53113	RL1954
L220	220 μ H	671 27020	PE-52626	RL1953
L330	330 μ H	671 27030	PE-52627	RL1952
L470	470 μ H	671 27040	PE-53114	RL1951
L680	680 μ H	671 27050	PE-52629	RL1950
H150	150 μ H	671 27060	PE-53115	RL2445
H220	220 μ H	671 27070	PE-53116	RL2446
H330	330 μ H	671 27080	PE-53117	RL2447
H470	470 μ H	671 27090	PE-53118	RL1961
H680	680 μ H	671 27100	PE-53119	RL1960
H1000	1000 μ H	671 27110	PE-53120	RL1959
H1500	1500 μ H	671 27120	PE-53121	RL1958
H2200	2200 μ H	671 27130	PE-53122	RL2448

Inductor Selection Guide

V_R	Schottky		Fast Recovery	
	3A	4A-6A	3A	4A-6A
20V	1N5820 MBR320P SR302	1N5823	The following diodes are all rated to 100V 31DF1 HER302	The following diodes are all rated to 100V 50WF10 MUR410 HER602
30V	1N5821 MBR330 31DQ03 SR303	50WQ03 1N5824		
40V	1N5822 MBR340 31DQ04 SR304	MBR340 50WQ04 1N5825		
50V	MBR350 31DQ05 SR305	50WQ05		
60V	MBR360 DQ06 SR306	50WR06 50SQ060		

Diode Selection Guide

Grounding

To maintain output voltage stability, the power ground connections must be low-impedance. For the 5-lead TO-220T and TO-263 style package, both the tab and pin 3 are ground and either connection may be used, as they are both part of the same copper lead frame.

Heat Sink/Thermal Considerations

In many cases, only a small heat sink is required to keep the D2576HV junction temperature within the allowed operating range. For each application, to determine whether or not a heat sink will be required, the following must be identified:

1. Maximum ambient temperature (in the application).
2. Maximum regulator power dissipation (in application).
3. Maximum allowed junction temperature (125°C for the D2576HV). For a safe, conservative design, a temperature approximately 15°C cooler than the maximum temperatures should be selected.
4. D2576HV package thermal resistances θ_{JA} and θ_{JC} .

Total power dissipated by the D2576HV can be estimated as follows:

$$P_D = (V_{IN})(I_Q) + (V_O/V_{IN})(I_{LOAD})(V_{SAT})$$

where

- I_Q (quiescent current) and V_{SAT} can be found in Typical Performance Characteristics shown previously,
- V_{IN} is the applied minimum input voltage, V_O is the regulated output voltage,
- and I_{LOAD} is the load current. (3)

The dynamic losses during turn-on and turn-off are negligible if a Schottky type catch diode is used.

When no heat sink is used, the junction temperature rise can be determined by the following:

$$\Delta T_J = (P_D) (\theta_{JA}) \quad (4)$$

To arrive at the actual operating junction temperature, add the junction temperature rise to the maximum ambient temperature.

$$T_J = \Delta T_J + T_A \quad (5)$$

If the actual operating junction temperature is greater than the selected safe operating junction temperature determined in step 3, then a heat sink is required.

When using a heat sink, the junction temperature rise can be determined by the following:

$$\Delta T_J = (P_D) (\theta_{JC} + \theta_{interface} + \theta_{Heat\ sink}) \quad (6)$$

The operating junction temperature will be:

$$T_J = T_A + \Delta T_J \quad (7)$$

If the actual operating junction temperature is greater than the selected safe operating junction temperature, then a larger heat sink is required (one that has a lower thermal resistance). Included on the Switcher Made Simple design software is a more precise (non-linear) thermal model that can be used to determine junction temperature with different input-output parameters or different component values. It can also calculate the heat sink thermal resistance required to maintain the regulators junction temperature below the maximum operating temperature.

Characteristic Curves

Dropout Voltage

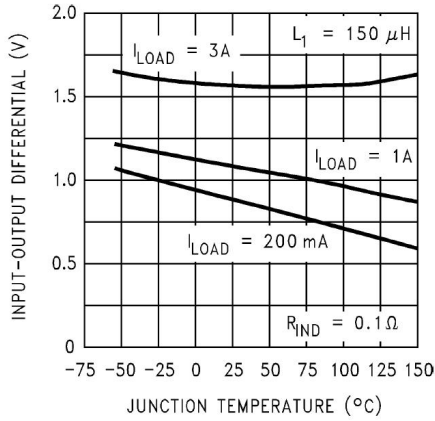

01147629

Current Limit

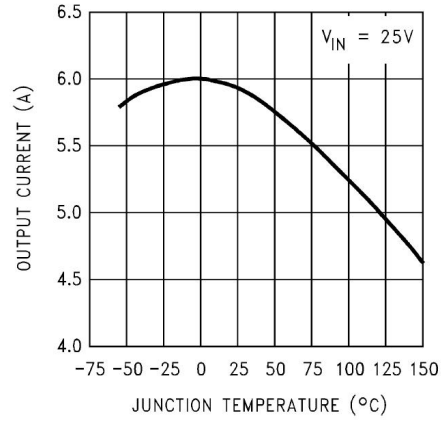

01147630

Quiescent Current

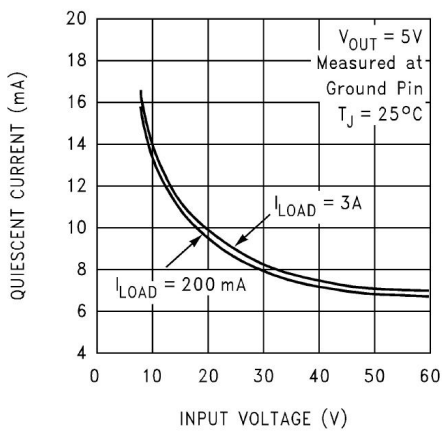

01147631

Standby Quiescent Current

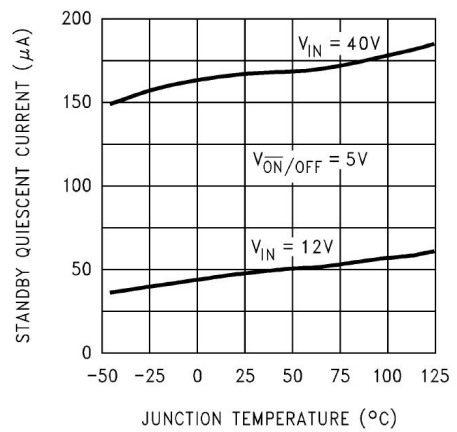

01147632

Oscillator Frequency

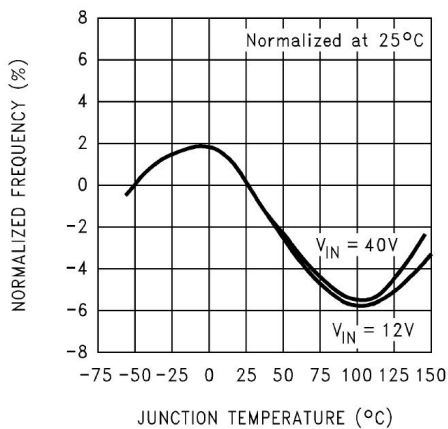

Switch Saturation Voltage

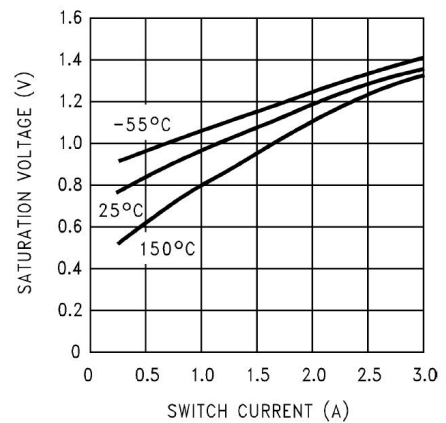

Characteristic Curves (Continued)

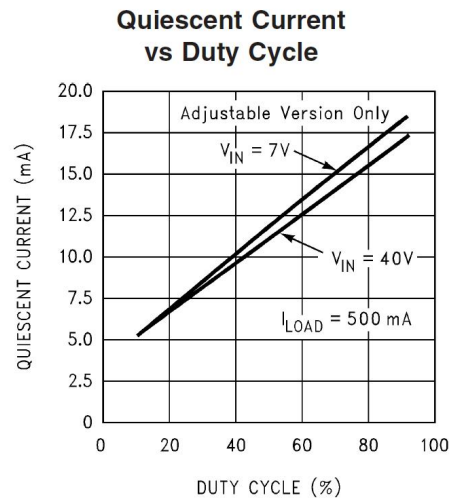
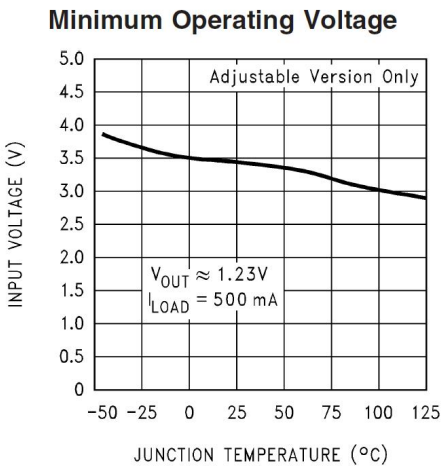
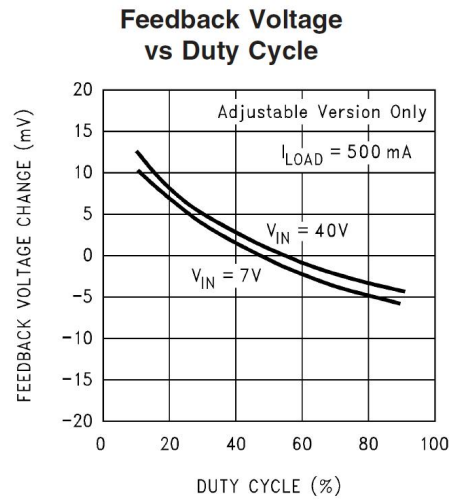
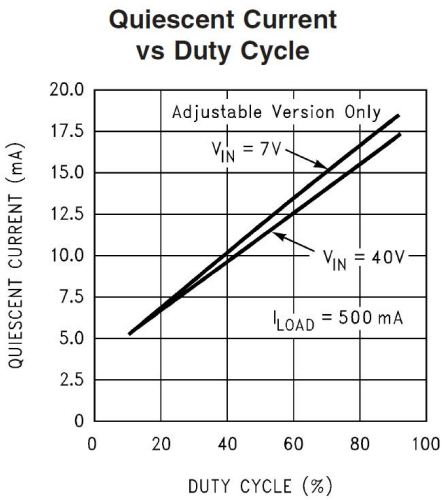
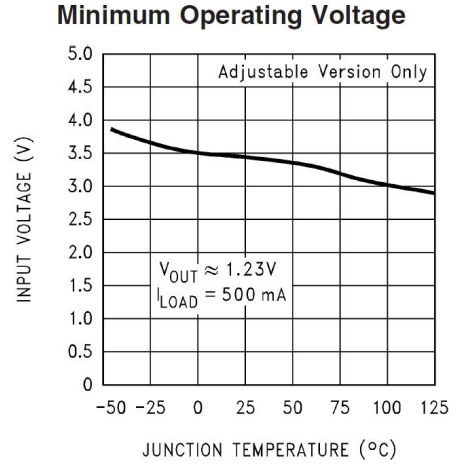
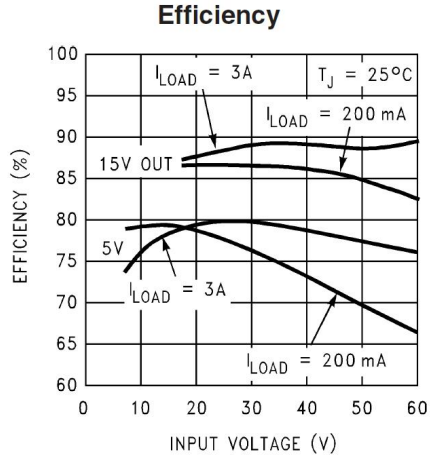

Characteristic Curves (Continued)

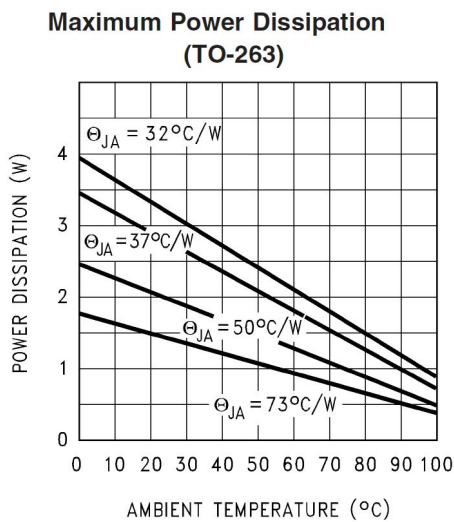
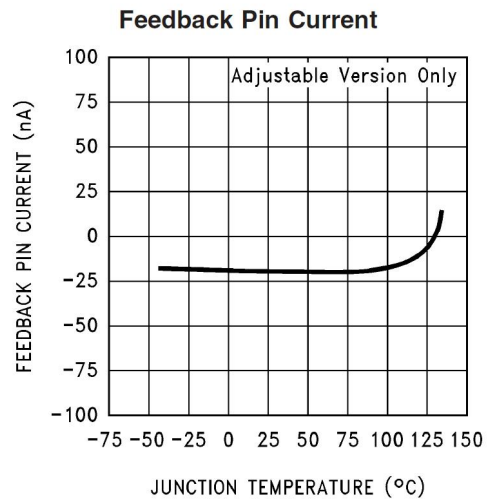
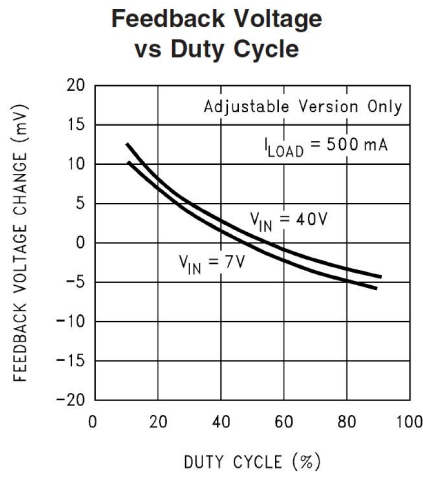
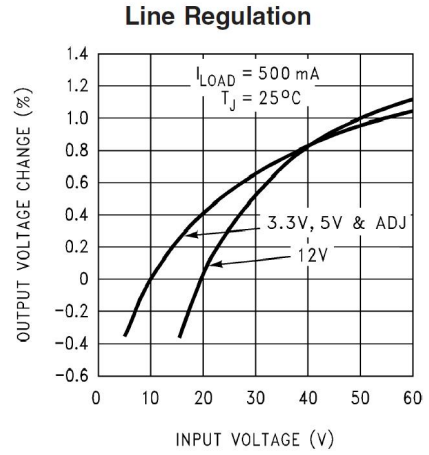
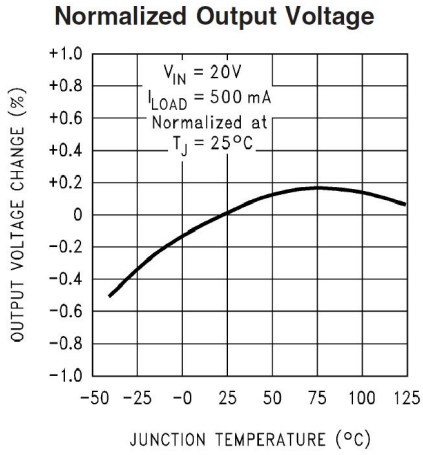

Outline Dimensions

TO220T-5L:

Unit: mm

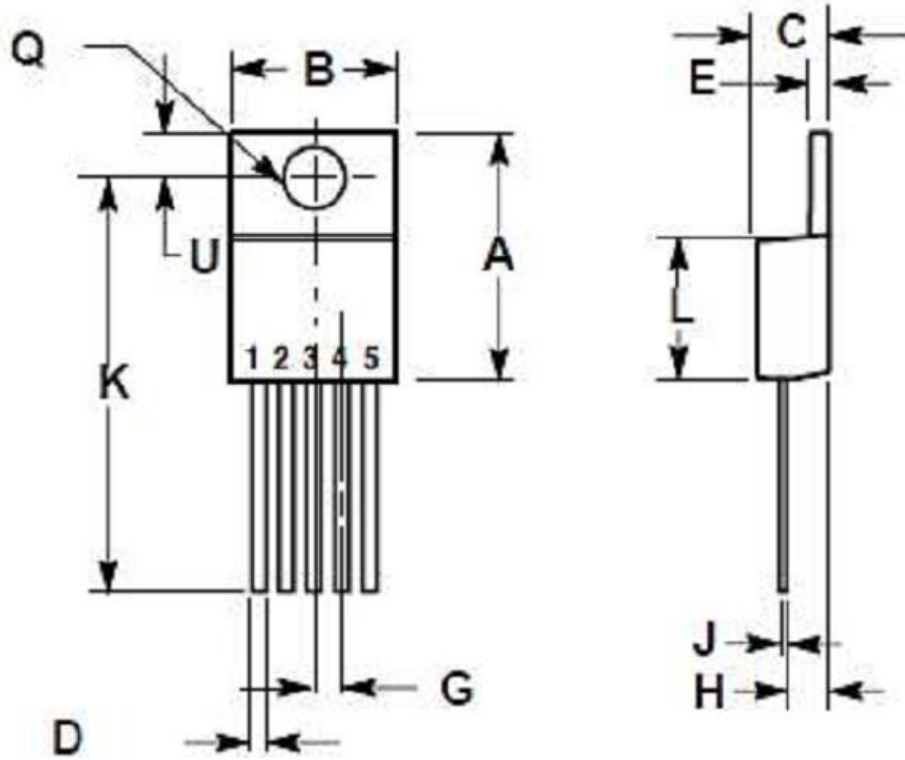

项目	规范 (mm)	
	Min	Min
A	15.500	15.900
B	9.804	10.236
C	4.318	4.572
D	0.66	0.914
E	1.143	1.397
G	1.702BSC	
H	2.235	2.591
J	0.356	0.406
K	26.100	26.500
L	9.042	9.347
Q	3.790	3.890
U	2.600	2.700

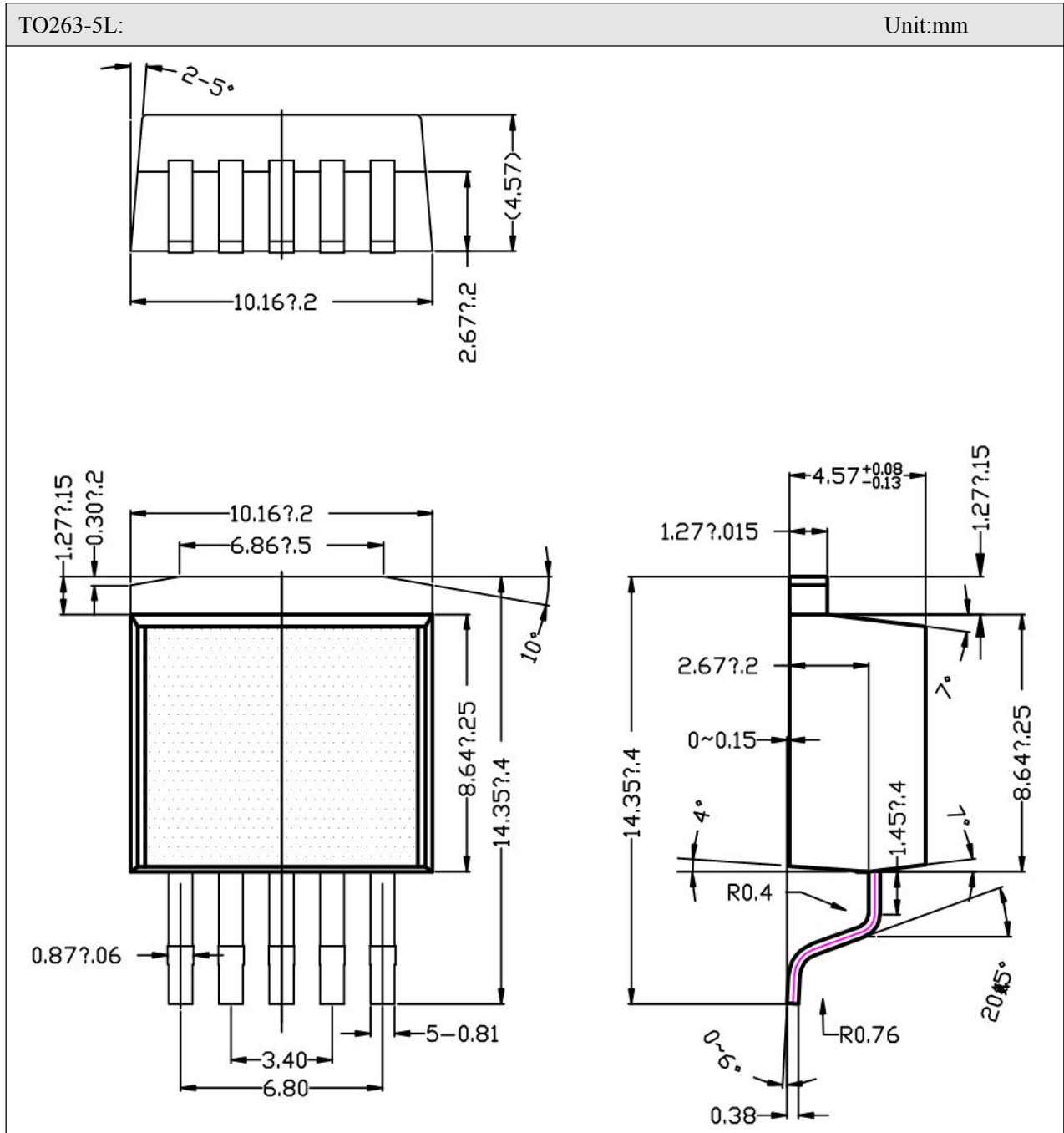

Statements

- Silicore Technology reserves the right to make changes without further notice to any products or specifications herein. Before customers place an order, customers need to confirm whether datasheet obtained is the latest version, and to verify the integrity of the relevant information.
- Failure or malfunction of any semiconductor products may occur under particular conditions, customers shall have obligation to comply with safety standards when customers use Silicore Technology products to do their system design and machine manufacturing, and take corresponding safety measures in order to avoid potential risk of failure that may cause personal injury or property damage.
- The product upgrades without end, Silicore Technology will wholeheartedly provide customers integrated circuits that have better performance and better quality.