

Features

- ◇ Trench Schottky Barrier technology
- ◇ Ultra low forward voltage drop
- ◇ Low power loss,high efficiency
- ◇ Excellent low reverse leakages
- ◇ Excellent high temperature stability
- ◇ High current capability
- ◇ High forward surge capability
- ◇ Lead free finish ,Rohs and WEEE compliant.

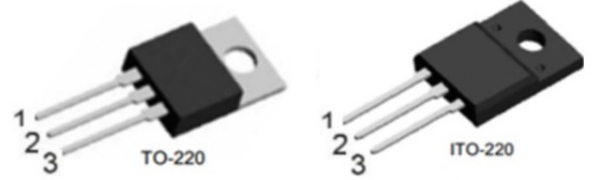

Applications

- ◇ Switching diode
- ◇ Switching mode power supply(SMPS)
- ◇ DC/DC converter
- ◇ LED lighting
- ◇ Adapter for notebook and game station

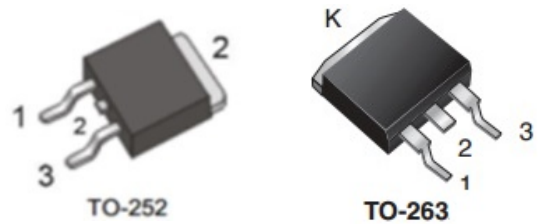

Mechanical Data

- ◇ Moisture Sensitivity: MSL Level 1,per J-STD-020
- ◇ Terminals:Matte Tin Finish.
Solderable per MIL-STD-202 Method 208
- ◇ Case Material: Molded Plastic;
Molding compound meet UL Flammability Classification Rating 94V-0
- ◇ Case:JEDEC TO-220AB,ITO-220AB,TO-252,TO-263

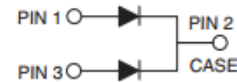

MAXIMUM RATING

Ratings at 25°C ambient temperature unless otherwise specified.

PARAMETER	SYMBOL	VALUE	UNITS	
Maximum repetitive peak reverse voltage	V_{RRM}	100	V	
Maximum RMS voltage	V_{RWS}	70	V	
Maximum DC blocking voltage	V_{DC}	100	V	
Maximum average forward rectified current	$I_{F(AV)}$	20	A	
per device		10		
Per diode				
Peak forward surge current 8.3ms half-sine-wave	I_{FSM}	200	A	
I^2t Rating for Fusing($t < 8.3ms$)	I^2t	166	A^2s	
Typical Thermal Resistance	TO-220AB	$R_{\theta JA}$	23	$^{\circ}C/W$
		$R_{\theta JC}$	2.5	$^{\circ}C/W$
		$R_{\theta JL}$	3.0	$^{\circ}C/W$
	ITO-220AB	$R_{\theta JC}$	4.5	$^{\circ}C/W$
	TO-252	$R_{\theta JC}$	2.5	$^{\circ}C/W$
	TO-263	$R_{\theta JC}$	2.5	$^{\circ}C/W$
Typical junction capacitance: $V_R=4.0v, f=1MHz$	C_J	620	pF	
Junction temperature	T_J	150	$^{\circ}C$	
Storage temperature range	T_{STG}	-55~150	$^{\circ}C$	



**MBR20100LCT/MBRF20100LCT
MBR20100LDT/MB20100LMT**

Low VF Trench Schottky Rectifiers



ELECTRICAL CHARACTERISTICS

PARAMETER	TEST CONDITIONS	SYMBOL	VALUE			UNITS	
			Min	Typ	Max		
Breakdown voltage per diode(min)	IR=0.5mA	V _{BR}	100	-	-	V	
Instantaneous forward voltage	IF=10A per Ige	TA= 25°C	VF	-	0.68	0.72	V
		TA= 100°C	VF	-	0.66	0.70	V
		TA= 125°C	VF	-	0.65	0.69	V
	IF=5A per Ige	TA= 25°C	VF	-	0.54	0.58	V
		TA= 100°C	VF	-	0.52	0.56	V
		TA= 125°C	VF	-	0.51	0.55	V
	IF=3A per Ige	TA= 25°C	VF	-	0.46	0.52	V
		TA= 100°C	VF	-	0.44	0.50	V
		TA= 125°C	VF	-	0.43	0.49	V
Maximum DC reverse current @Rated DC Blocking Vlotage	TA= 25°C	IR	-	10	50	μ A	
	TA=125°C	IR	-	-	20000	μ A	

ORDERING PACK INFORMATION

Part No.	Package	Pcking	Box Size L×W×H(mm)	Quatity(pcs/box)	Carton Size L×W×H(mm)	Quatity(pcs/carton)
MBR20100LCT	TO-220	50pcs/Tube	558×148×38	1000	565×225×170	5000
MBRF20100LCT	ITO-220	50pcs/Tube	558×148×38	1000	565×225×170	5000
MBR20100LDT	TO-252	50pcs/Tube	558×148×38	1000	565×225×170	5000
MBR20100LMT	TO-263	50pcs/Tube	558×148×38	4000	565×225×170	20000



RATING AND CHARACTERISTICS CURVES

MBR20100LCT/MBRF20100LCT MBR20100LDT/MB20100LMT Low VF Trench Schottky Rectifiers



FIG.1-FORWARD CURRENT DERATING CURVE

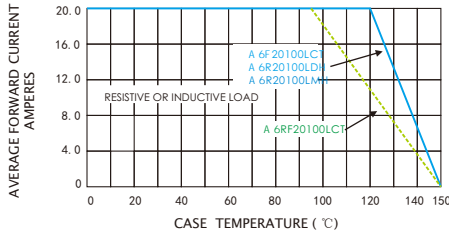

FIG.2-MAXIMUM NON-REPETITIVE PEAK FORWARD SURGE CURRENT

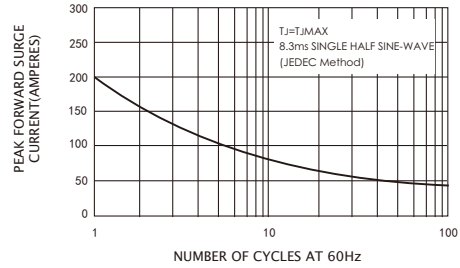

FIG.3-TYPICAL INSTANTANEOUS FORWARD CHARACTERISTICS

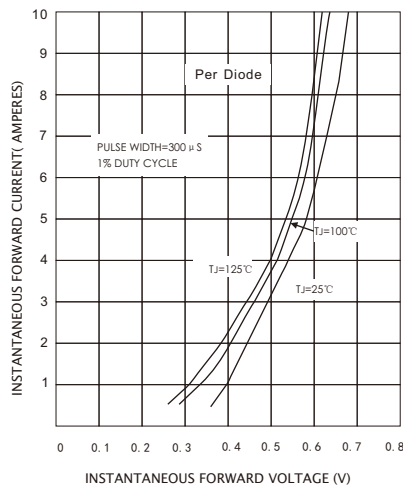

FIG.4-TYPICAL REVERSE CHARACTERISTICS

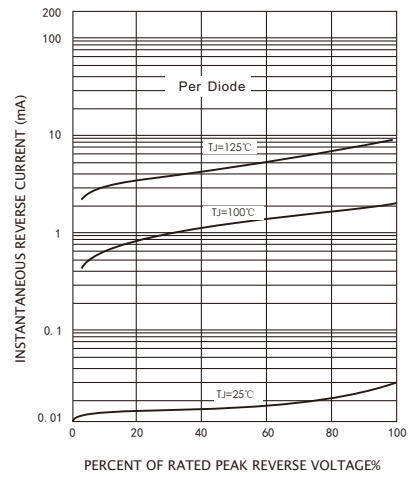
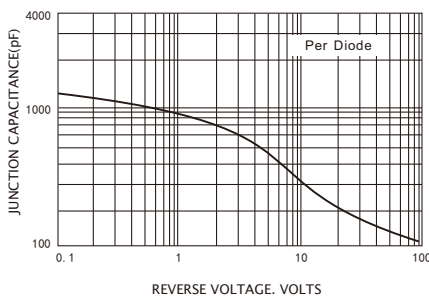

FIG.5-TYPICAL JUNCTION CAPACITANCE



PACKAGE OUTLINE DIMENSIONS

Dimensions in inches and (millimeters)

TO-220AB

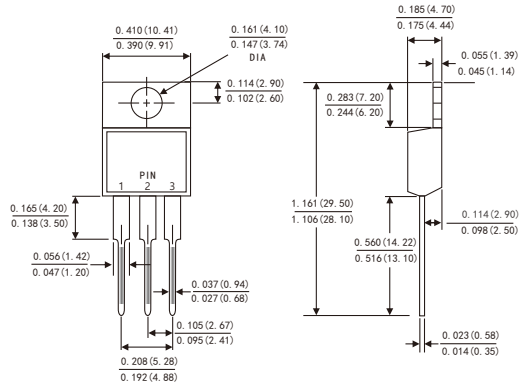

ITO-220AB

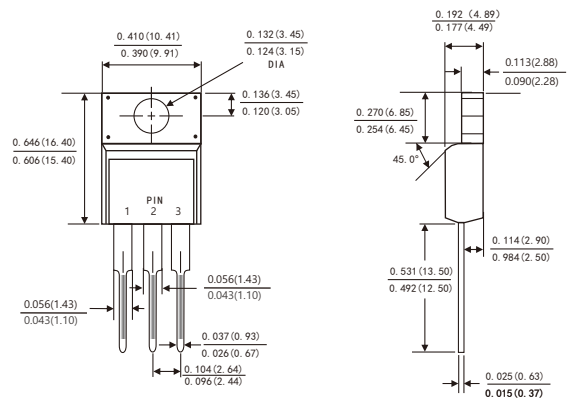

TO-263

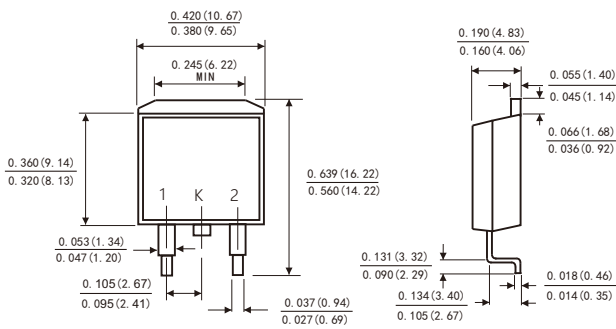

TO-252

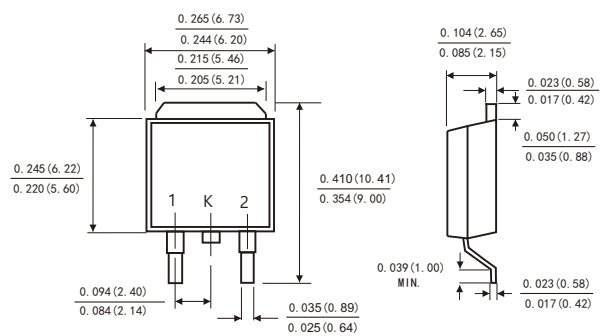

Suggested Pad Layout

(TO-263)

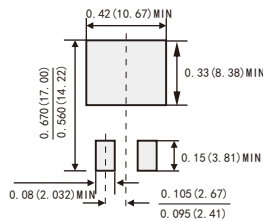

Suggested Pad Layout

(TO-252)

