

LNTA7002NT1G

S-LNTA7002NT1G

Small Signal MOSFET

1. FEATURES

- Low Gate Charge for Fast Switching
- Small 1.6 X 1.6 mm Footprint
- ESD Protected Gate
- ESD Protected:2000V
- We declare that the material of product compliance with RoHS requirements and Halogen Free.
- S- prefix for automotive and other applications requiring unique site and control change requirements; AEC-Q101 qualified and PPAP capable.

2. APPLICATIONS

- Power Management Load Switch
- Level Shift
- Portable Applications such as Cell Phones, Media Players, Digital Cameras, PDA's, Video Games, Hand Held Computers, etc.

3. DEVICE MARKING AND RESISTOR VALUES

Device	Marking	Shipping
LNTA7002NT1G	T6	3000/Tape&Reel
LNTA7002NT3G	T6	10000/Tape&Reel

4. MAXIMUM RATINGS(Ta = 25°C)

Parameter	Symbol	Limits	Unit
Drain-to-Source Voltage	VDSS	30	V
Gate-to-Source Voltage	VGS	±10	V
Continuous Drain Current (Note 1)	ID	154	mA
Power Dissipation (Note 1)	PD	300	mW
Pulsed Drain Current (tp ≤ 10 μs)	IDM	618	mA
Operating Junction and Storage Temperature	Tj, Tstg	-55~+150	°C
Continuous Source Current (Body Diode)	ISD	154	mA
Lead Temperature for Soldering Purposes (1/8" from case for 10 s)	TL	260	°C

5. THERMAL CHARACTERISTICS

Parameter	Symbol	Limits	Unit
Junction-to-Ambient – Steady State (Note 1)	RθJA	416	°C/W

1. Surface-mounted on FR4 board using 1 in sq pad size

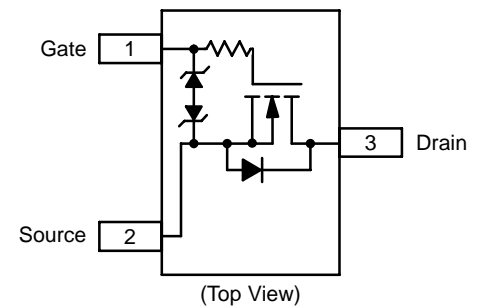
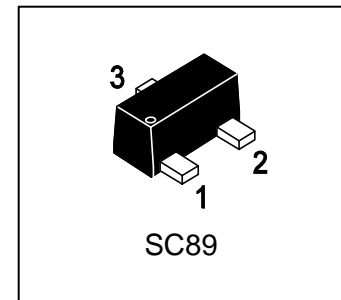

MARKING DIAGRAM

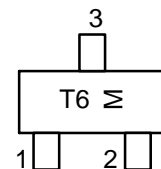

T6 = Specific Device Code
M = Month Code

6. ELECTRICAL CHARACTERISTICS (Ta= 25°C)

Characteristic	Symbol	Min.	Typ.	Max.	Unit
OFF CHARACTERISTICS					
Drain–Source Breakdown Voltage (VGS = 0, ID = 100μA)	VBRDSS	30	-	-	V
Zero Gate Voltage Drain Current (VGS = 0, VDS = 30 V) (VGS = 0, VDS = 20 V, Tj = 85 °C)	IDSS	-	-	1	μA
Gate-to–Source Leakage Current (VDS = 0 V, VGS = ±10 V) (VDS = 0 V, VGS = ±5 V) (VDS = 0 V, VGS = ±5 V, Tj = 85 °C)	IGSS	-	-	±25 ±1 ±1	μA
ON CHARACTERISTICS (Note 2)					
Gate Threshold Voltage (VDS = VGS, ID = 100μA)	VGS(th)	0.5	1	1.5	V
Drain–to–Source On Resistance (VGS = 4.5 V, ID = 154 mA) (VGS = 2.5 V, ID = 154 mA)	RDS(on)	-	1.4 2.3	7 7.5	Ohm
Forward Transconductance (VDS = 3 V, ID = 154 mA)	gfs	-	80	-	mS
CAPACITANCES					
Input Capacitance (VDS = 5.0 V, f = 1 MHz, VGS = 0 V)	Ciss	-	11.5	-	pF
Output Capacitance (VDS = 5.0 V, f = 1 MHz, VGS = 0 V)	Coss	-	10	-	pF
Reverse Transfer Capacitance (VDS = 5.0 V, f = 1 MHz, VGS = 0 V)	Crss	-	3.5	-	pF
SWITCHING CHARACTERISTICS (Note 3)					
Turn–On Delay Time	VGS = 4.5 V, VDS = 5.0 V, ID = 75 mA, RG = 10 Ohm	td(ON)	13		ns
Rise Time		tr	15		
Turn–Off Delay Time		td(OFF)	98		
Fall Time		tf	60		
Drain–Source Diode Characteristics					
Diode Forward Voltage (VGS = 0 V, IS = 154 mA)	VSD	-	0.77	0.9	V

2. Pulse Test: pulse width $\leq 300 \mu\text{s}$, duty cycle $\leq 2\%$.

3. Switching characteristics are independent of operating junction temperatures.

7. ELECTRICAL CHARACTERISTICS CURVES

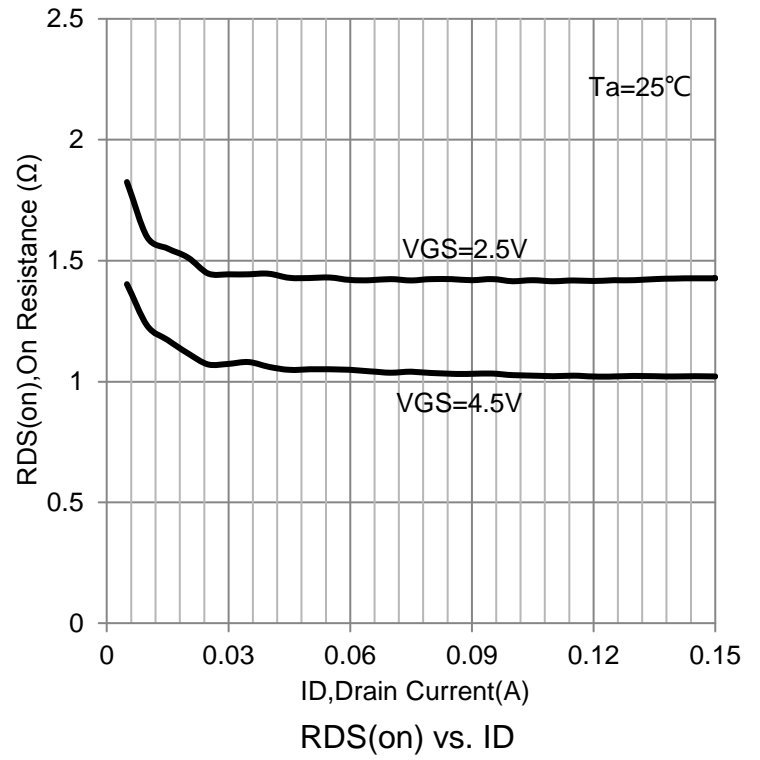
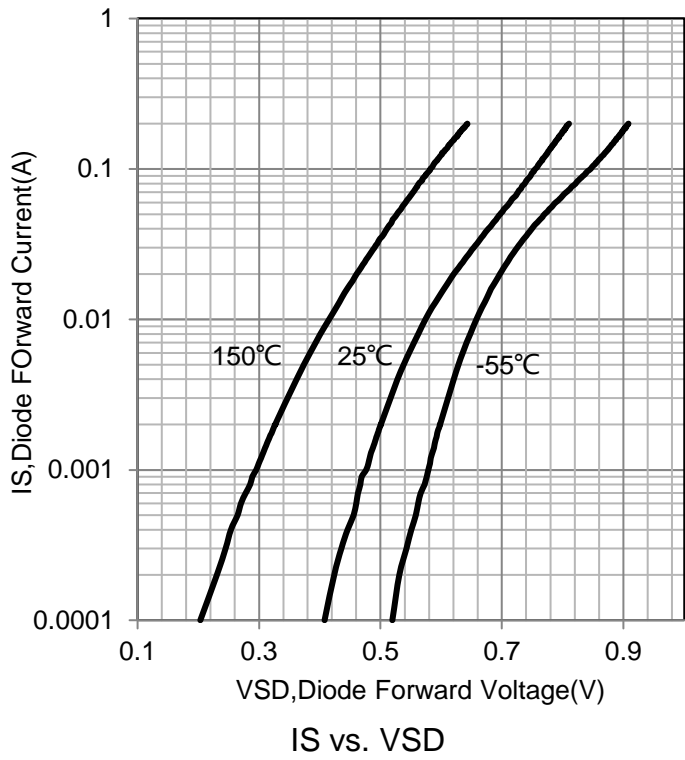
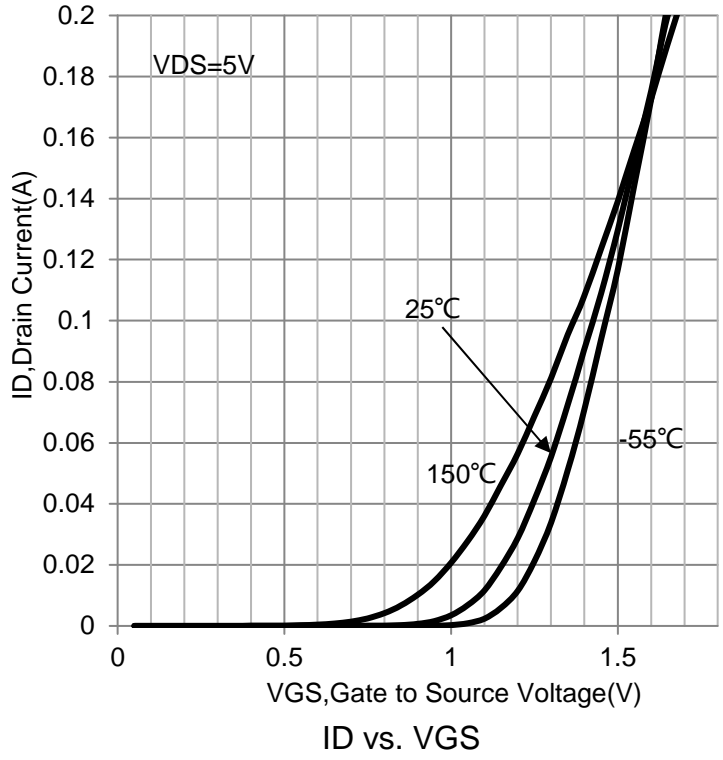
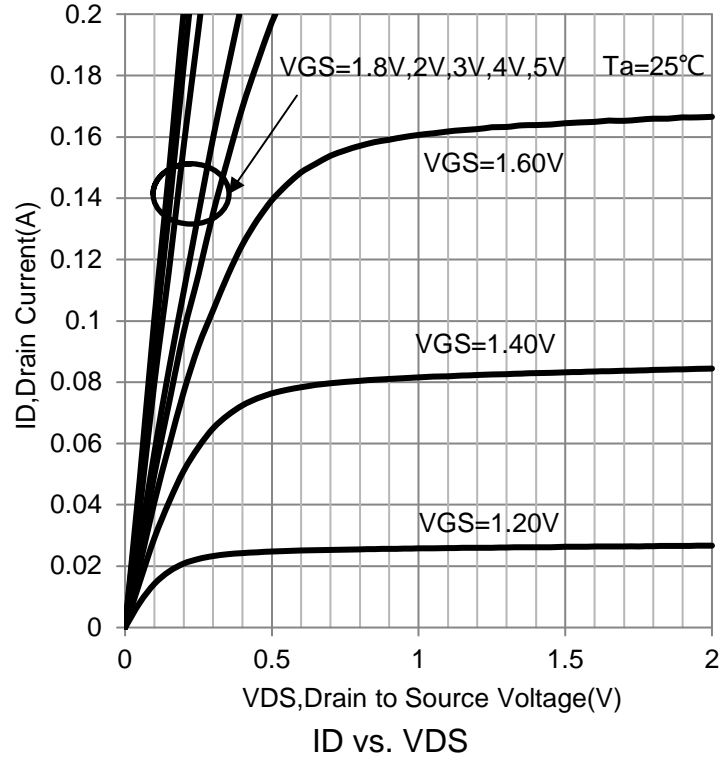

7.ELECTRICAL CHARACTERISTICS CURVES(Con.)

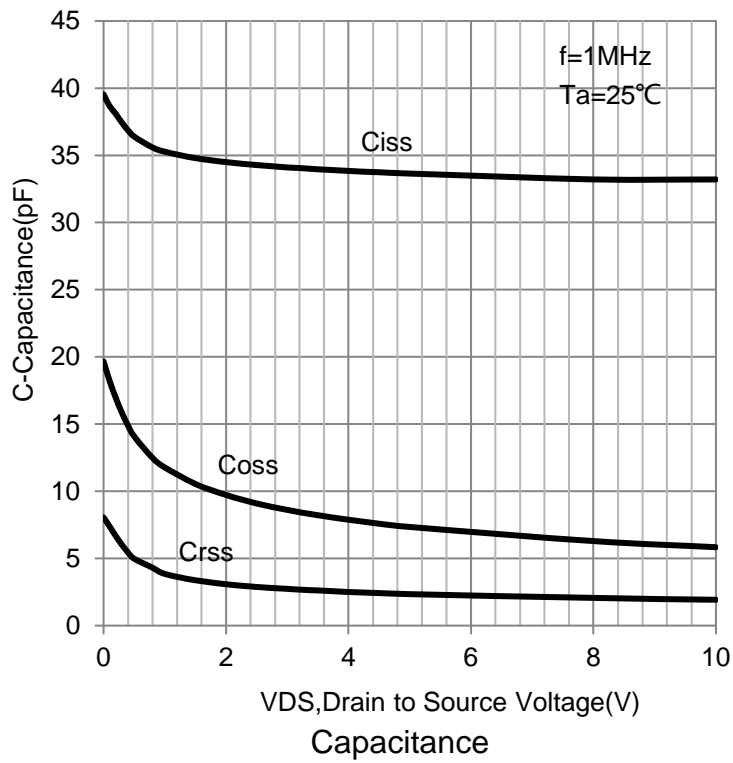
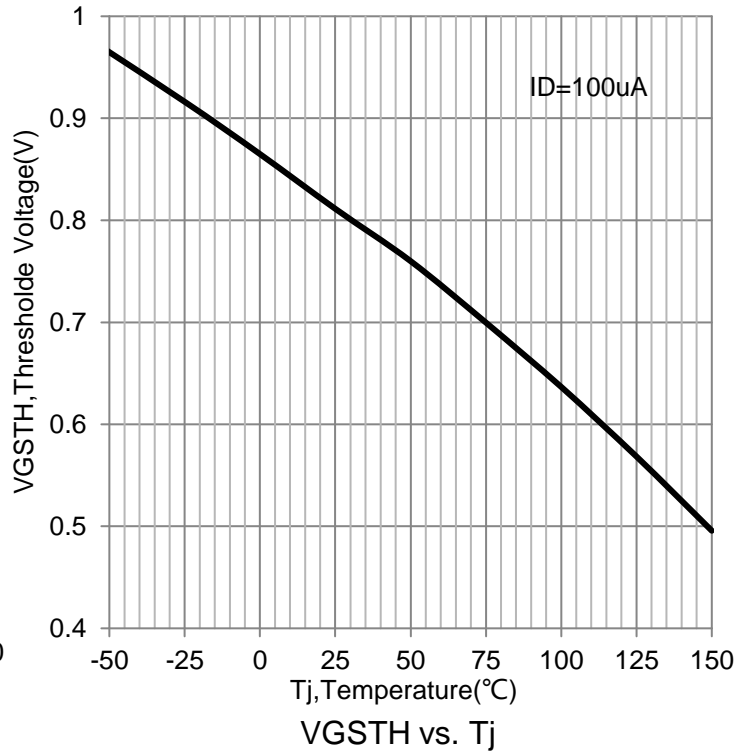
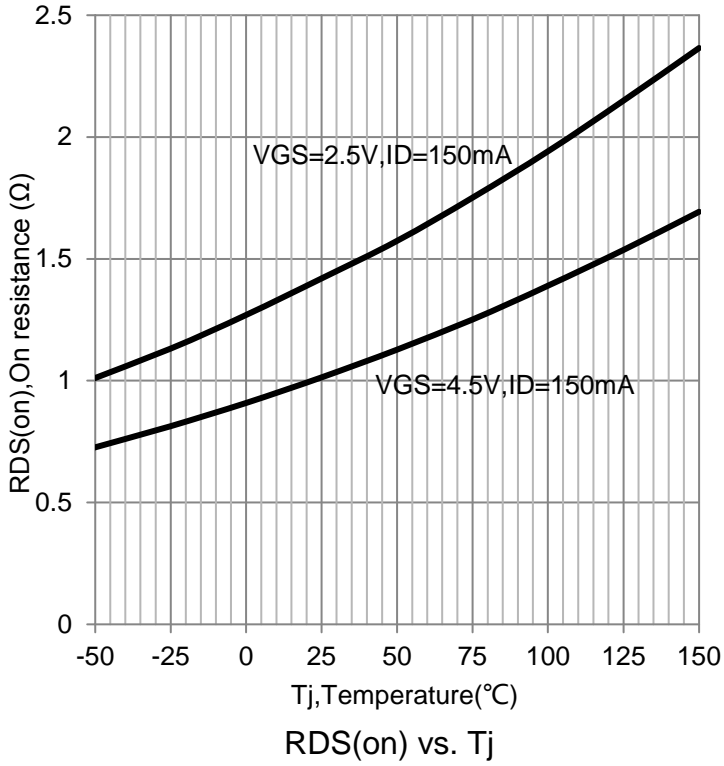

8. OUTLINE AND DIMENSIONS

Notes:

1. DIMENSIONING AND TOLERANCING PER ANSI Y14.5M, 1982.
2. CONTROLLING DIMENSION: MILLIMETERS.
3. MAXIMUM LEAD THICKNESS INCLUDES LEAD FINISH. MINIMUM LEAD THICKNESS IS THE MINIMUM THICKNESS OF BASE MATERIAL.
4. DIMENSIONS A AND B DO NOT INCLUDE MOLD FLASH, PROTRUSIONS OR GATE BURRS.

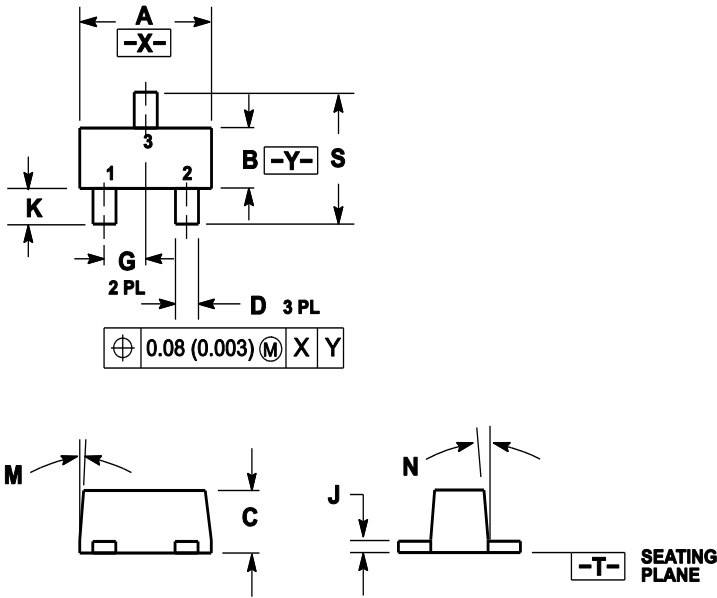

DIM	MILLIMETERS			INCHES		
	MIN	NOM	MAX	MIN	NOM	MAX
A	1.50	1.60	1.70	0.059	0.063	0.067
B	0.75	0.85	0.95	0.030	0.034	0.040
C	0.60	0.70	0.80	0.024	0.028	0.031
D	0.23	0.28	0.33	0.009	0.011	0.013
G	0.50BSC			0.020BSC		
H	0.53REF			0.021REF		
J	0.10	0.15	0.20	0.004	0.006	0.008
K	0.30	0.40	0.50	0.012	0.016	0.02
L	1.10REF			0.043REF		
M	---	---	10°	---	---	10°
N	---	---	10°	---	---	10°
S	1.50	1.60	1.70	0.059	0.063	0.067

9. SOLDERING FOOTPRINT

