

规格承认书
Specification for approval

客户名称:
(Customer Name)

产品名称:
(Product Name)

客户料号:
(Customer part number)

科尼盛料号:
(KNSCHA number)

型号规格:
(Specifications)

铝电解电容

Aluminum Electrolytic Capacitor

22UF400V87EC0284

KNSCHA MHT 400V22μF Φ10*13L

KNSCHA MHT 400V22μF Φ10*13L

制 造
(Manufacture)

Approval

拟 制
(Fiction)

审 核
(Chief)

核 准
(Approval)



刘淑芬

刘军军

徐贵南

客 户
(Customer)

Approval

检 验
(Inspect)

审 核
(Chief)

核 准
(Approval)

东莞市科尼盛电子有限公司

DONG GUAN KNSCHA ELECTRONICS CO.,LTD.

No. The 8th Floor, A3 Building, R&D Center (Phase I),

Songshan Lake Intelligent Valley, Liaobu Town, Dongguan City.

TEL:0769-83698067 81035570

FAX: 0769-83861559

Email: sales@knscha.com Website: http://www.knscha.com



MHT Series

Aluminum Electrolytic Capacitors

Item Name	Rating	Case size	KNSCHA Lifetime
22UF400V87EC0284	MHT400V22 μ F	Φ 10*13L	4000 hours

1. Operating Temp. Range

-25°C ~ +105°C

2. Electrical Characteristics

See Table 1.

【Table 1】

Rated Voltage VDC	Surge Voltage VDC	Nominal Static Capacitance (μ F)	Tolerance on Capacitance(%) 20°C 120Hz	Dissipation Factor ($\tan \delta$) max 20°C 120Hz	Leakage Current 5min. 20°C (μ A)max	Permissible Ripple Current (mA rms) max 105°C 100KHz
400	450	22	-20~+20	0.20	191	255

3. Dimensions

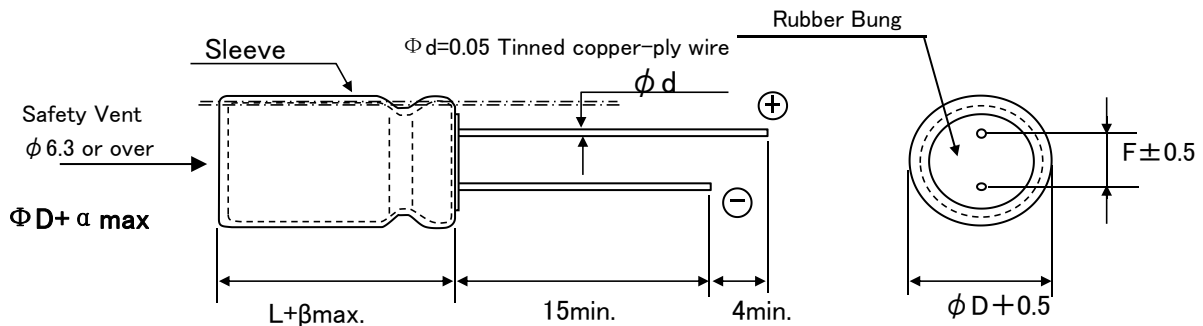

Unit(mm)

$\phi D + 0.5$ Max	L \pm 1.5 Max	F \pm 0.5	d \pm 0.05
10	13	5.0	0.6

4. Marking

Following items are printed with gold color on black color sleeve

Example of Marking

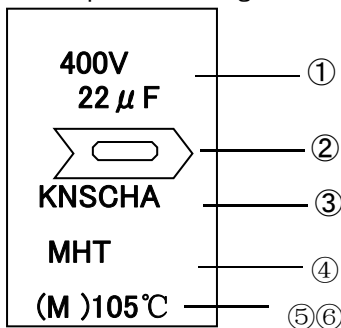

- ① Rated voltage & Nominal Capacitance
- ② Polarity (negative)
- ③ Trade Mark
- ④ series
- ⑤ Symbol of Capacitance Tolerance (M)
- ⑥ Max Operating Temp.

5. MULTIPLIER FOR RIPPLE CURRENT

①. Frequency Coefficient

Cap (μ F) \backslash Freq. (Hz)	60 (50)	120	300	1K	10K	100K
0.1-47	0.55	0.65	0.70	0.75	0.85	1.00
68-680	0.65	0.75	0.80	0.85	0.90	1.00
1000-15000	0.70	0.80	0.85	0.90	0.95	1.00

②. Temperature Coefficient

Ambient Temperature (°C)	40	60	70	85	105
Coefficient	2.40	2.10	1.78	1.65	1.00

6. Characteristics

No.	Item	Performance	Test Method								
1	Leakage Current	$I = 191.0 \mu A$ ($I = 0.02CV + 15 \mu A$) I= Max Leakage Current C=Static Capacitor: V=Rated Voltage	Protection Resistor : $1000 \pm 10 \Omega$ Applied Volt : Rated Voltage Measuring time : 5minutes								
2	Static Capacitance	17.6 ~ 26.4 μF	Measured Frequency : $120Hz \pm 20\%$ Measured Voltage $\leq 0.5V_{rms}$, 1.5 ~ 2.0VDC								
3	Dissipation Factor (tan δ)	0.20 and Under	Same as condition of Capacitors								
4	High Temp. Load Characteristics	Leakage Current	\leq the value specified in Table 1	Test Temp. : $105 \pm 2^\circ C$ Applied voltage: Rated voltage Test Time :4,000 hours +72, -0 hours							
		Cap. Change	$\leq \pm 20\%$ of initial value								
		Dissipation Factor	$\leq 200\%$ of value specified in Table								
		Appearance	No remarkable abnormality								
5	High Temp. no load Characteristics	Leakage Current	\leq the value specified in Table 1	Test Temp. : $105 \pm 2^\circ C$ No voltage applied Test Time :1000 hours +24, -0 hurs							
		Cap. Change	$\leq \pm 20\%$ of initial value								
		Dissipation Factor	$\leq 200\%$ of value specified in Table								
		Appearance	No remarkable abnormality								
6	Terminal Strength	Tensile Strength	45N {4.5kg}	Keeping time Tensile 1~5sec Bending 30 ± 5 sec							
		Bending Strength	25N {2.5kg}								
7	Impedance Ratio	<table border="1"> <thead> <tr> <th>W V</th> <th></th> </tr> </thead> <tbody> <tr> <td>Z-25°C/Z+20°C</td> <td>400</td> </tr> <tr> <td>Z-40°C/Z+20°C</td> <td>8</td> </tr> <tr> <td></td> <td>-</td> </tr> </tbody> </table>	W V		Z-25°C/Z+20°C	400	Z-40°C/Z+20°C	8		-	
W V											
Z-25°C/Z+20°C	400										
Z-40°C/Z+20°C	8										
	-										
8	Temperature Characteristics	Stage	Item	Performance	Stage	Test Temp(°C)					
		2,3	Impedance Ratio	less than the value mentioned in 5-7,	1	20±2					
		5	Cap. Change	$\leq \pm 25\%$ against value in stage 4	2	-25±3;					
		After the capacitor is held at temperature of each stage and reaches temperature stability, measure performance.			3	-25±3;					
					4	20±2					
					5	105±2					
6	20±2										
9	Surge Voltage	Item	Performance	Test Temp. 15~35°C Test volt. Surge Volt.Specified in 2 Voltage apply. 1,000times of chage for 30 ± 5 sec, under frequency of 6 ± 0.5 sec, and discharge for 5min30sec.							
		Leakage Current	\leq the initial specified value								
		Cap. Change	$\leq \pm 15\%$ against value before test								
		Dissipation Factor	\leq the initial specified value								
		Appearance	No remarkable abnormality								

6-2. Characteristics

No.	Item	Performance	Test Method								
10	Vibration Resistance	<table border="1"> <tr> <td>Capacitance</td> <td>Stability required</td> </tr> <tr> <td>Cap. Change</td> <td>≤±5% of the initial specified value</td> </tr> <tr> <td>Appearance</td> <td>No remarkable abnormality</td> </tr> </table> <p>Frequency : 10~55Hz/1min. Width of vibration, 1.5mm Direction and duration X, Y and Z directions, each for 2 hours (Total 9 hours)</p>	Capacitance	Stability required	Cap. Change	≤±5% of the initial specified value	Appearance	No remarkable abnormality			
Capacitance	Stability required										
Cap. Change	≤±5% of the initial specified value										
Appearance	No remarkable abnormality										
11	Solderbility	3/4 area of surrounding directions of surface should be covered with new solder.	Solder: Sn-Ag, Sn-Cu Type Soldering Temp : 240±5°C Dipping degree : 2~2.5mm Flux : Ethanol solution (JIS K8101) or Isopropylalchol (JIS K8839) solution of Rosin (JIS K5902)								
12	Resistance to Soldering	<table border="1"> <tr> <td>Leakage Current</td> <td>≤ Initial specified value</td> </tr> <tr> <td>Cap. Change</td> <td>≤ ±10% of initial value</td> </tr> <tr> <td>Dissipation Factor</td> <td>≤ Initial specified in value</td> </tr> <tr> <td>Appearance</td> <td>No remarkable abnormality</td> </tr> </table>	Leakage Current	≤ Initial specified value	Cap. Change	≤ ±10% of initial value	Dissipation Factor	≤ Initial specified in value	Appearance	No remarkable abnormality	Soldering Temp. 280±5°C Soldering Time . 10±1sec.
Leakage Current	≤ Initial specified value										
Cap. Change	≤ ±10% of initial value										
Dissipation Factor	≤ Initial specified in value										
Appearance	No remarkable abnormality										
13	Resistance to Humidity	<table border="1"> <tr> <td>Leakage Current</td> <td>≤ Initial specified value</td> </tr> <tr> <td>Cap. Change</td> <td>≤ ±15% of initial value</td> </tr> <tr> <td>Dissipation Factor</td> <td>≤ Initial specified value</td> </tr> <tr> <td>Appearance</td> <td>No remarkable abnormality</td> </tr> </table>	Leakage Current	≤ Initial specified value	Cap. Change	≤ ±15% of initial value	Dissipation Factor	≤ Initial specified value	Appearance	No remarkable abnormality	Test Temp. : 40±2°C Humidity 90~95% Test Time : 500 ± 8 hours After the above condition,restored to normal temp, and then measured.
Leakage Current	≤ Initial specified value										
Cap. Change	≤ ±15% of initial value										
Dissipation Factor	≤ Initial specified value										
Appearance	No remarkable abnormality										
14	Perssure valve moment charact-erstics	There must not be thing ignition, scattering the resolution that that case works safely	Dcmethod: impress the reverse voltage and of 1A, I cancel an electric current.								

7 Packing method

Packaging shape, size, quantity

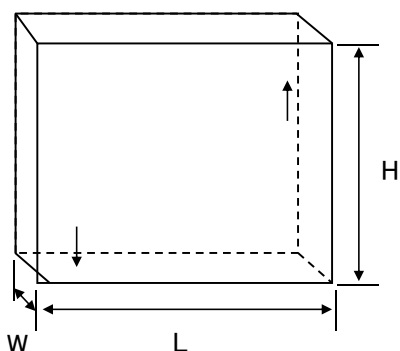

Component size	Quantity per
10*13	10000pcs.

8 Related Standards JIS C 5141

9 Marking on packing box

- ① Item name
- ② Series name
- ③ Rated Voltage
- ④ Nominal Static Capacitance
- ⑤ Case size
- ⑥ Lot No.
- ⑦ Quantity

10 Leakage current

<Condition>

Connecting the capacitor with a protective resistor ($1k\Omega \pm 10\Omega$) in series for 2 minutes, and then, measure leakage current.

<Criteria

I : Leakage current (μA)

$I(\mu A) \leq I = 0.02CV + 15\mu A$ (μA) whichever is greater, measurement circuit refer to right drawing.

C: Capacitance (μF)

11 Soldeing

11-1 Soldering by soldering iron

Temperature of iron top : 270~350°C

Operating time : within 3 sec.

11-2 Flow soldering.

Preheat : PCB surface temperature $120^\circ C \pm 5^\circ C$

Solder Temp : $260^\circ C \pm 5^\circ C$

Solder Dipping Temp. : 2~4sec.

12 Cleaning of PC board after soldering

Using follwing solvents is possible but make sure followingcondition

Solvent

IPA or Alcoholic agent like Pinealpha ST-100S, Cleanthrough 750H, 750L, 710M, 750K, or Technocare FRW-14~17

- ① Cleaning should be made by ultrasonic within 5min, at the temperature less then $60^\circ C$.
- ② Control of pollution is necessary (conductivity,pH, specific gravity, water volume)
- ③ Please do not keep near cleaning agent. Please do not store in air-tight container. Please let it dry by hot air at the temperature less than maximum operating temp.

13 The situation of using

Please do not use a condenser in the next use environment.

① One circumference environment(weatherability) condition.

(a) Direct water,salt water and environment oil works or become a dew condensation state.

(b) Environment full of harmful gas (a hydrogen chloride, sulfurous acid.

nitrous acid hydrochloric acid, ammonia).

(c) Ozone, infrared rays and the environment where radioactive rays are done collation of

② Vibration shock condition is extreme environment more than rule ranges of delivery specifications.

14 A country of origin

A country of origin of an KNSCHA SHG series alminum electrolysis condenser of specifications:

China

15 Effective life for storage

Storage conditions:

① Temperature range must be between $5-35^\circ C$

② Relative humidity must be less than 75%

③ Must be stored indoor

④ Must be free from water, oil or salt water

⑤ Must be free from toxic gasses (hydrogen sulfide, sulfurous acid, chlorine, ammonium, etc.)

⑥ Must be free from ozone, ultraviolet rays or any other radiation

⑦ Must be kept in capacitor original package

Aluminum Electrolytic Capacitor MHT Series Structure

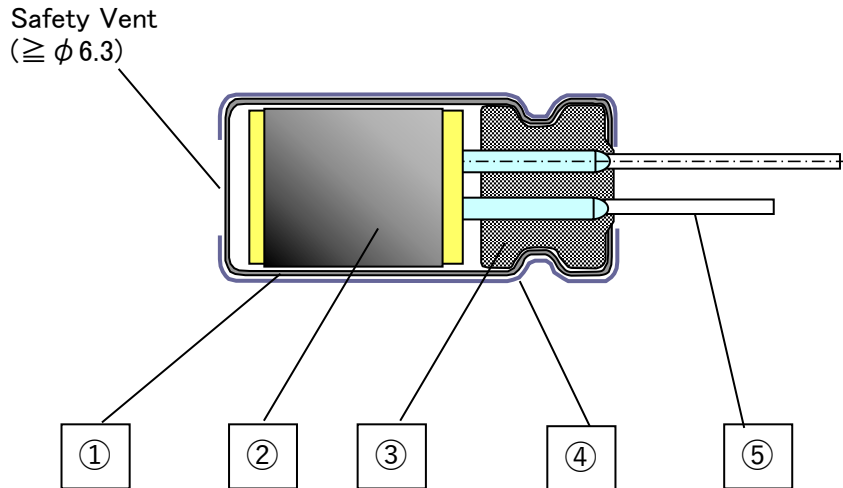

No.	Name	Material
①	Case	Aluminum
②	Element (Electrode)	High Purity Aluminum foil
	(Separator)	Manila hemp pulp
	(Electrolyte)	---
③	Rubber Bung	Synthetic Rubber
④	Sleeve	PET
⑤	Lead Wire	Tin plated Steel Wire

Controls of ozone layer destructive chemical materials

Regulated materials : CFCs, Halon, Carbon Tetrachloride, 1.1.1-Trichloroethane

The products and parts do not include the above materials

The products and parts are not used the above materials on process.

The products and parts are not used PBBOs (Poly Bromo Bi-phenyl Oxides).

All materials are mentioned as existing chemical material in the "Law of examine and control of Production of Chemical Material"

The products are not listed in Appendix 1 of Export Trade Rule and Regulation

A condenser of this series supports RoHS regulation.