

# MC74VHCT50A

## Noninverting Buffer / CMOS Logic Level Shifter with LSTTL-Compatible Inputs

The MC74VHCT50A is a hex noninverting buffer fabricated with silicon gate CMOS technology. It achieves high speed operation similar to equivalent Bipolar Schottky TTL while maintaining CMOS low power dissipation.

The internal circuit is composed of three stages, including a buffered output which provides high noise immunity and stable output.

The device input is compatible with TTL-type input thresholds and the output has a full 5 V CMOS level output swing. The input protection circuitry on this device allows overvoltage tolerance on the input, allowing the device to be used as a logic-level translator from 3.0 V CMOS logic to 5.0 V CMOS Logic or from 1.8 V CMOS logic to 3.0 V CMOS Logic while operating at the high-voltage power supply.

The MC74VHCT50A input structure provides protection when voltages up to 7 V are applied, regardless of the supply voltage. This allows the MC74VHCT50A to be used to interface 5 V circuits to 3 V circuits. The output structures also provide protection when  $V_{CC} = 0$  V. These input and output structures help prevent device destruction caused by supply voltage – input/output voltage mismatch, battery backup, hot insertion, etc.

### Features

- High Speed:  $t_{PD} = 3.5$  ns (Typ) at  $V_{CC} = 5$  V
- Low Power Dissipation:  $I_{CC} = 2$   $\mu$ A (Max) at  $T_A = 25^\circ$ C
- TTL-Compatible Inputs:  $V_{IL} = 0.8$  V;  $V_{IH} = 2.0$  V
- CMOS-Compatible Outputs:  $V_{OH} > 0.8 V_{CC}$ ;  $V_{OL} < 0.1 V_{CC}$  @Load
- Power Down Protection Provided on Inputs and Outputs
- NLV Prefix for Automotive and Other Applications Requiring Unique Site and Control Change Requirements; AEC-Q100 Qualified and PPAP Capable
- These Devices are Pb-Free and are RoHS Compliant

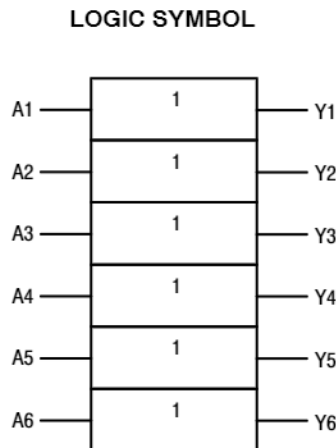
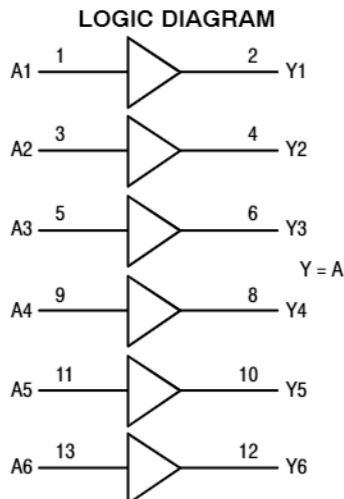

**ON Semiconductor®**

<http://onsemi.com>



14-LEAD SOIC  
D SUFFIX  
CASE 751A

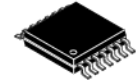

14-LEAD TSSOP  
DT SUFFIX  
CASE 948G

### PIN CONNECTION AND MARKING DIAGRAM (Top View)

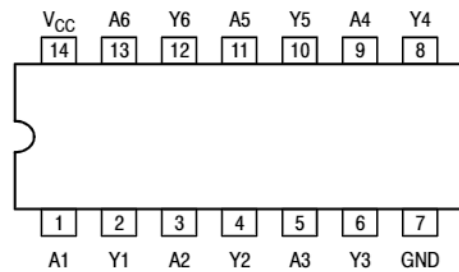

For detailed package marking information, see the Marking Diagram section on page 4 of this data sheet.

### FUNCTION TABLE

| A Input | Y Output |
|---------|----------|
| L       | L        |
| H       | H        |

### ORDERING INFORMATION

See detailed ordering and shipping information in the package dimensions section on page 4 of this data sheet.

# MC74VHCT50A

## MAXIMUM RATINGS

| Symbol         | Parameter   | Value                     | Unit |
|----------------|---|---------------------------|------|
| $V_{CC}$       | DC Supply Voltage   | -0.5 to +7.0              | V    |
| $V_{IN}$       | DC Input Voltage  | $-0.5 \leq V_I \leq +7.0$ | V    |
| $V_{OUT}$      | DC Output Voltage<br>Output in HIGH or LOW State  | $-0.5 \leq V_O \leq +7.0$ | V    |
| $I_{IK}$       | DC Input Diode Current  | -20                       | mA   |
| $I_{OK}$       | DC Output Diode Current   | $\pm 20$                  | mA   |
| $I_O$          | DC Output Source/Sink Current   | $\pm 25$                  | mA   |
| $I_{CC}$       | DC Supply Current per Supply Pin  | $\pm 50$                  | mA   |
| $I_{GND}$      | DC Ground Current per Ground Pin  | $\pm 50$                  | mA   |
| $T_{STG}$      | Storage Temperature Range   | -65 to +150               | °C   |
| $T_L$          | Lead Temperature, 1 mm from Case for 10 Seconds   | 260                       | °C   |
| $T_J$          | Junction Temperature under Bias   | +150                      | °C   |
| $\theta_{JA}$  | Thermal Resistance<br>(Note 1)<br>SOIC<br>TSSOP   | 125<br>170                | °C/W |
| $P_D$          | Power Dissipation in Still Air<br>SOIC<br>TSSOP   | 500<br>450                | mW   |
| $V_{ESD}$      | ESD Withstand Voltage<br>Human Body Model (Note 2)<br>Machine Model (Note 3)<br>Charged Device Model (Note 4) | > 2000<br>> 200<br>2000   | V    |
| $I_{Latch-Up}$ | Latch-Up Performance<br>Above $V_{CC}$ and Below GND at 85°C (Note 5)   | $\pm 300$                 | mA   |

Stresses exceeding those listed in the Maximum Ratings table may damage the device. If any of these limits are exceeded, device functionality should not be assumed, damage may occur and reliability may be affected.

1. Measured with minimum pad spacing on an FR4 board, using 10 mm-by-1 inch, 2-ounce copper trace with no air flow.
2. Tested to EIA/JESD22-A114-A.
3. Tested to EIA/JESD22-A115-A.
4. Tested to JESD22-C101-A.
5. Tested to EIA/JESD78.

## RECOMMENDED OPERATING CONDITIONS

| Characteristics  | Symbol     | Min        | Max             | Unit |
|--|------------|------------|-----------------|------|
| DC Supply Voltage  | $V_{CC}$   | 2.0        | 5.5             | V    |
| DC Input Voltage   | $V_{IN}$   | 0.0        | 5.5             | V    |
| DC Output Voltage<br>$V_{CC} = 0$<br>High or Low State   | $V_{OUT}$  | 0.0<br>0.0 | 5.5<br>$V_{CC}$ | V    |
| Operating Temperature Range  | $T_A$      | -55        | +125            | °C   |
| Input Rise and Fall Time<br>$V_{CC} = 3.3 \text{ V} \pm 0.3 \text{ V}$<br>$V_{CC} = 5.0 \text{ V} \pm 0.5 \text{ V}$ | $t_r, t_f$ | 0<br>0     | 100<br>20       | ns/V |

Functional operation above the stresses listed in the Recommended Operating Ranges is not implied. Extended exposure to stresses beyond the Recommended Operating Ranges limits may affect device reliability.

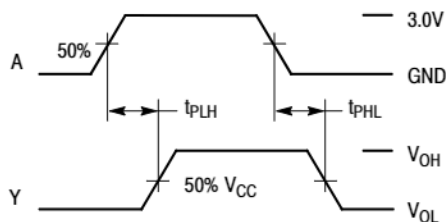
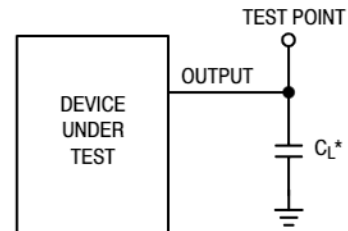

Figure 1. Switching Waveforms



\*Includes all probe and jig capacitance

Figure 2. Test Circuit

# MC74VHCT50A

## DC ELECTRICAL CHARACTERISTICS

| Symbol             | Parameter   | Test Conditions  | V <sub>CC</sub><br>(V) | T <sub>A</sub> = 25°C |            |                    | T <sub>A</sub> ≤ 85°C |                    | T <sub>A</sub> ≤ 125°C |                    | Unit         |
|--------------------|---|--|------------------------|-----------------------|------------|--------------------|-----------------------|--------------------|------------------------|--------------------|--------------|
|                    |   |  |                        | Min                   | Typ        | Max                | Min                   | Max                | Min                    | Max                |              |
| V <sub>IH</sub>    | Minimum High-Level Input Voltage  |  | 3.0<br>4.5<br>5.5      | 1.2<br>2.0<br>2.0     |            |                    | 1.2<br>2.0<br>2.0     |                    | 1.2<br>2.0<br>2.0      | V                  |              |
| V <sub>IL</sub>    | Maximum Low-Level Input Voltage   |  | 3.0<br>4.5<br>5.5      |                       |            | 0.53<br>0.8<br>0.8 |                       | 0.53<br>0.8<br>0.8 |                        | 0.53<br>0.8<br>0.8 | V            |
| V <sub>OH</sub>    | Minimum High-Level Output Voltage<br>V <sub>IN</sub> = V <sub>IH</sub> or V <sub>IL</sub> | V <sub>IN</sub> = V <sub>IH</sub> or V <sub>IL</sub><br>I <sub>OH</sub> = -50 μA                           | 3.0<br>4.5             | 2.9<br>4.4            | 3.0<br>4.5 |                    | 2.9<br>4.4            |                    | 2.9<br>4.4             | V                  |              |
|                    |   | V <sub>IN</sub> = V <sub>IH</sub> or V <sub>IL</sub><br>I <sub>OH</sub> = -4 mA<br>I <sub>OH</sub> = -8 mA | 3.0<br>4.5             | 2.58<br>3.94          |            |                    | 2.48<br>3.80          |                    | 2.34<br>3.66           | V                  |              |
| V <sub>OL</sub>    | Maximum Low-Level Output Voltage<br>V <sub>IN</sub> = V <sub>IH</sub> or V <sub>IL</sub>  | V <sub>IN</sub> = V <sub>IH</sub> or V <sub>IL</sub><br>I <sub>OL</sub> = 50 μA                            | 3.0<br>4.5             |                       | 0.0<br>0.0 | 0.1<br>0.1         |                       | 0.1<br>0.1         |                        | 0.1<br>0.1         | V            |
|                    |   | V <sub>IN</sub> = V <sub>IH</sub> or V <sub>IL</sub><br>I <sub>OH</sub> = -4 mA<br>I <sub>OL</sub> = 8 mA  | 3.0<br>4.5             |                       |            |                    | 0.36<br>0.36          |                    | 0.44<br>0.44           |                    | 0.52<br>0.52 |
| I <sub>IN</sub>    | Maximum Input Leakage Current   | V <sub>IN</sub> = 5.5 V or GND   | 0 to<br>5.5            |                       |            | ±0.1               |                       | ±1.0               |                        | ±1.0               | μA           |
| I <sub>CC</sub>    | Maximum Quiescent Supply Current  | V <sub>IN</sub> = V <sub>CC</sub> or GND   | 5.5                    |                       |            | 2.0                |                       | 20                 |                        | 40                 | μA           |
| I <sub>CC(T)</sub> | Quiescent Supply Current  | Input: V <sub>IN</sub> = 3.4 V   | 5.5                    |                       |            | 1.35               |                       | 1.50               |                        | 1.65               | mA           |
| I <sub>OFF</sub>   | Output Leakage Current  | V <sub>OUT</sub> = 5.5 V   | 0.0                    |                       |            | 0.5                |                       | 5.0                |                        | 10                 | μA           |

Product parametric performance is indicated in the Electrical Characteristics for the listed test conditions, unless otherwise noted. Product performance may not be indicated by the Electrical Characteristics if operated under different conditions.

## AC ELECTRICAL CHARACTERISTICS (C<sub>load</sub> = 50 pF, Input t<sub>r</sub> = t<sub>f</sub> = 3.0ns)

| Symbol                                 | Parameter                                  | Test Conditions   | T <sub>A</sub> = 25°C |            |             | T <sub>A</sub> ≤ 85°C |             | T <sub>A</sub> ≤ 125°C |             | Unit |
|--|--|---|-----------------------|------------|-------------|-----------------------|-------------|------------------------|-------------|------|
|  |  |   | Min                   | Typ        | Max         | Min                   | Max         | Min                    | Max         |      |
| t <sub>PLH</sub> ,<br>t <sub>PHL</sub> | Maximum Propagation Delay,<br>Input A to Y | V <sub>CC</sub> = 3.3 ± 0.3 V    C <sub>L</sub> = 15 pF<br>C <sub>L</sub> = 50 pF |                       | 5.5<br>8.0 | 7.9<br>11.4 | 1.0<br>1.0            | 9.5<br>13.0 |                        |             | ns   |
|  |  | V <sub>CC</sub> = 5.0 ± 0.5 V    C <sub>L</sub> = 15 pF<br>C <sub>L</sub> = 50 pF |                       | 6.2<br>7.0 | 7.5<br>8.5  |                       | 8.5<br>9.5  |                        | 9.5<br>10.5 |      |
| C <sub>IN</sub>                        | Maximum Input Capacitance                  |   |                       | 5<br>10    |             |                       | 10          |                        | 10          | pF   |

|                 |  |   |  |    |
|-----------------|--|---|--|----|
| C <sub>PD</sub> | Power Dissipation Capacitance (Note 6) | Typical @ 25°C, V <sub>CC</sub> = 5.0 V |  | pF |
|                 |  | 15                                      |  |    |

6. C<sub>PD</sub> is defined as the value of the internal equivalent capacitance which is calculated from the operating current consumption without load. Average operating current can be obtained by the equation: I<sub>CC(OPR)</sub> = C<sub>PD</sub> • V<sub>CC</sub> • f<sub>in</sub> + I<sub>CC</sub>. C<sub>PD</sub> is used to determine the no-load dynamic power consumption; P<sub>D</sub> = C<sub>PD</sub> • V<sub>CC</sub><sup>2</sup> • f<sub>in</sub> + I<sub>CC</sub> • V<sub>CC</sub>.

## NOISE CHARACTERISTICS (Input t<sub>r</sub> = t<sub>f</sub> = 3.0ns, C<sub>L</sub> = 50pF, V<sub>CC</sub> = 5.0V)

| Symbol           | Characteristic                               | T <sub>A</sub> = 25°C |      | Unit |
|------------------|--|-----------------------|------|------|
|                  |  | Typ                   | Max  |      |
| V <sub>OLP</sub> | Quiet Output Maximum Dynamic V <sub>OL</sub> | 0.8                   | 1.0  | V    |
| V <sub>OLV</sub> | Quiet Output Minimum Dynamic V <sub>OL</sub> | -0.8                  | -1.0 | V    |
| V <sub>IHD</sub> | Minimum High Level Dynamic Input Voltage     |                       | 2.0  | V    |
| V <sub>ILD</sub> | Maximum Low Level Dynamic Input Voltage      |                       | 0.8  | V    |

# MC74VHCT50A

## ORDERING INFORMATION

| Device           | Package               | Shipping†          |
|------------------|-----------------------|--------------------|
| MC74VHCT50ADR2G  | SOIC-14<br>(Pb-Free)  | 2500 / Tape & Reel |
| MC74VHCT50ADTR2G | TSSOP-14<br>(Pb-Free) | 2500 / Tape & Reel |
| NLVVHCT50ADTR2G* |                       |                    |

†For information on tape and reel specifications, including part orientation and tape sizes, please refer to our Tape and Reel Packaging Specifications Brochure, BRD8011/D.

\*NLV Prefix for Automotive and Other Applications Requiring Unique Site and Control Change Requirements; AEC-Q100 Qualified and PPAP Capable.

## MARKING DIAGRAMS

(Top View)

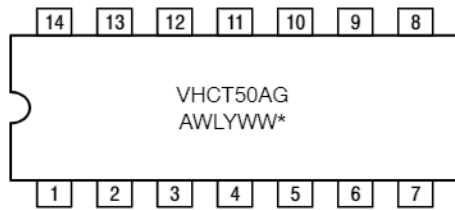

**14-LEAD SOIC**  
**D SUFFIX**  
**CASE 751A**

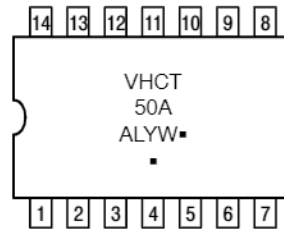

**14-LEAD TSSOP**  
**DT SUFFIX**  
**CASE 948G**

A = Assembly Location  
 WL, L = Wafer Lot  
 Y = Year  
 WW, W = Work Week  
 G or ▪ = Pb-Free Package

\*See Applications Note #AND8004/D for date code and traceability information.

# MC74VHCT50A

## PACKAGE DIMENSIONS

SOIC-14 NB  
D SUFFIX  
CASE 751A-03  
ISSUE K

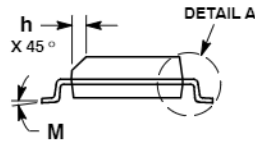
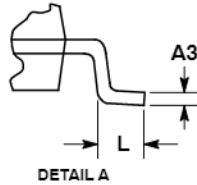
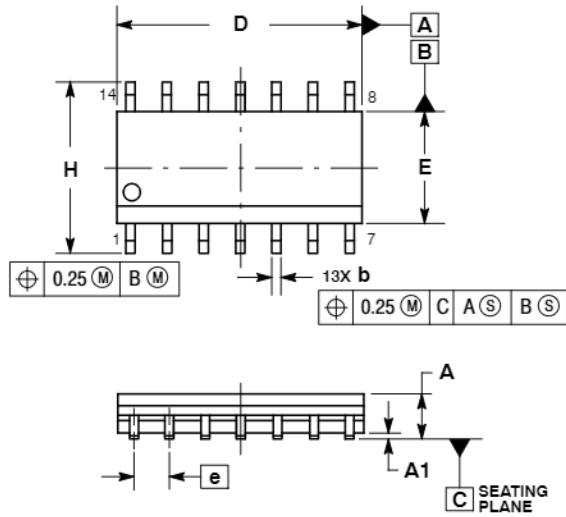

NOTES:

1. DIMENSIONING AND TOLERANCING PER ASME Y14.5M, 1994.
2. CONTROLLING DIMENSION: MILLIMETERS.
3. DIMENSION b DOES NOT INCLUDE DAMBAR PROTRUSION. ALLOWABLE PROTRUSION SHALL BE 0.13 TOTAL IN EXCESS OF AT MAXIMUM MATERIAL CONDITION.
4. DIMENSIONS D AND E DO NOT INCLUDE MOLD PROTRUSIONS.
5. MAXIMUM MOLD PROTRUSION 0.15 PER SIDE.

| DIM | MILLIMETERS |      | INCHES    |       |
|-----|-------------|------|-----------|-------|
|     | MIN         | MAX  | MIN       | MAX   |
| A   | 1.35        | 1.75 | 0.054     | 0.068 |
| A1  | 0.10        | 0.25 | 0.004     | 0.010 |
| A3  | 0.19        | 0.25 | 0.008     | 0.010 |
| b   | 0.35        | 0.49 | 0.014     | 0.019 |
| D   | 8.55        | 8.75 | 0.337     | 0.344 |
| E   | 3.80        | 4.00 | 0.150     | 0.157 |
| e   | 1.27 BSC    |      | 0.050 BSC |       |
| H   | 5.80        | 6.20 | 0.228     | 0.244 |
| h   | 0.25        | 0.50 | 0.010     | 0.019 |
| L   | 0.40        | 1.25 | 0.016     | 0.049 |
| M   | 0°          | 7°   | 0°        | 7°    |

### SOLDERING FOOTPRINT\*

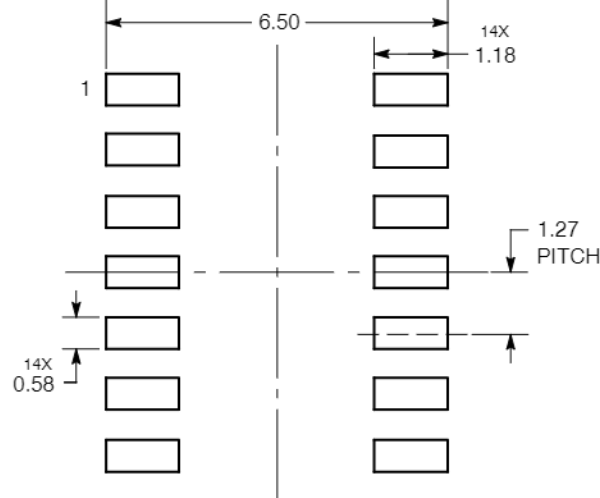

DIMENSIONS: MILLIMETERS

\*For additional information on our Pb-Free strategy and soldering details, please download the ON Semiconductor Soldering and Mounting Techniques Reference Manual, SOLDERRM/D.

# MC74VHCT50A

## PACKAGE DIMENSIONS

TSSOP-14  
CASE 948G  
ISSUE B

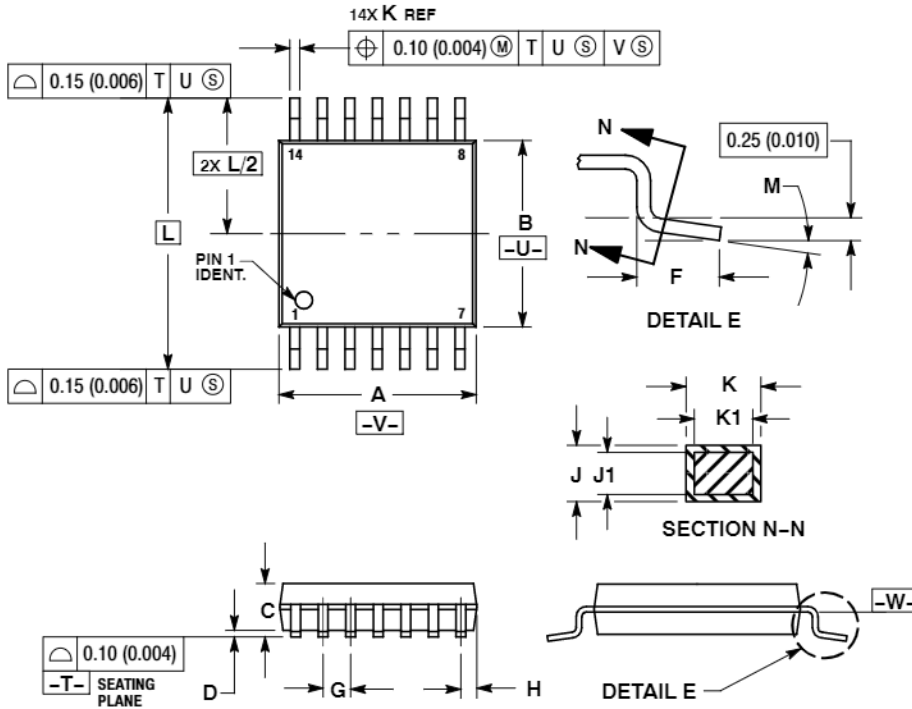

### NOTES:

1. DIMENSIONING AND TOLERANCING PER ANSI Y14.5M, 1982.
2. CONTROLLING DIMENSION: MILLIMETER.
3. DIMENSION A DOES NOT INCLUDE MOLD FLASH, PROTRUSIONS OR GATE BURRS. MOLD FLASH OR GATE BURRS SHALL NOT EXCEED 0.15 (0.006) PER SIDE.
4. DIMENSION B DOES NOT INCLUDE INTERLEAD FLASH OR PROTRUSION. INTERLEAD FLASH OR PROTRUSION SHALL NOT EXCEED 0.25 (0.010) PER SIDE.
5. DIMENSION K DOES NOT INCLUDE DAMBAR PROTRUSION. ALLOWABLE DAMBAR PROTRUSION SHALL BE 0.08 (0.003) TOTAL IN EXCESS OF THE K DIMENSION AT MAXIMUM MATERIAL CONDITION.
6. TERMINAL NUMBERS ARE SHOWN FOR REFERENCE ONLY.
7. DIMENSION A AND B ARE TO BE DETERMINED AT DATUM PLANE -W-.

| DIM | MILLIMETERS |      | INCHES    |       |
|-----|-------------|------|-----------|-------|
|     | MIN         | MAX  | MIN       | MAX   |
| A   | 4.90        | 5.10 | 0.193     | 0.200 |
| B   | 4.30        | 4.50 | 0.169     | 0.177 |
| C   | ---         | 1.20 | ---       | 0.047 |
| D   | 0.05        | 0.15 | 0.002     | 0.006 |
| F   | 0.50        | 0.75 | 0.020     | 0.030 |
| G   | 0.65 BSC    |      | 0.026 BSC |       |
| H   | 0.50        | 0.60 | 0.020     | 0.024 |
| J   | 0.09        | 0.20 | 0.004     | 0.008 |
| J1  | 0.09        | 0.16 | 0.004     | 0.006 |
| K   | 0.19        | 0.30 | 0.007     | 0.012 |
| K1  | 0.19        | 0.25 | 0.007     | 0.010 |
| L   | 6.40 BSC    |      | 0.252 BSC |       |
| M   | 0°          | 8°   | 0°        | 8°    |

### SOLDERING FOOTPRINT

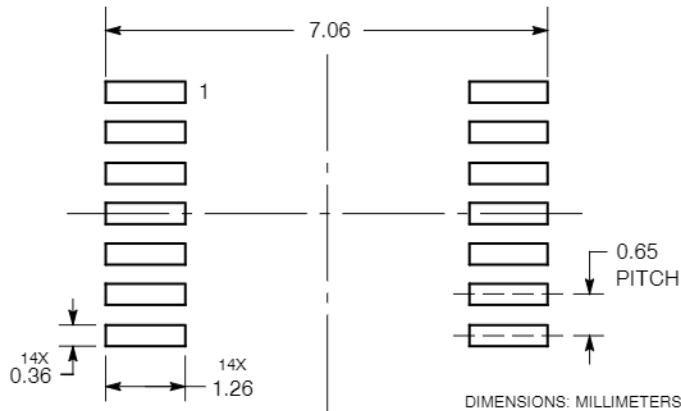

ON Semiconductor and are registered trademarks of Semiconductor Components Industries, LLC (SCILLC). SCILLC owns the rights to a number of patents, trademarks, copyrights, trade secrets, and other intellectual property. A listing of SCILLC's product/patent coverage may be accessed at [www.onsemi.com/site/pdf/Patent-Marking.pdf](http://www.onsemi.com/site/pdf/Patent-Marking.pdf). SCILLC reserves the right to make changes without further notice to any products herein. SCILLC makes no warranty, representation or guarantee regarding the suitability of its products for any particular purpose, nor does SCILLC assume any liability arising out of the application or use of any product or circuit, and specifically disclaims any and all liability, including without limitation special, consequential or incidental damages. "Typical" parameters which may be provided in SCILLC data sheets and/or specifications can and do vary in different applications and actual performance may vary over time. All operating parameters, including "Typicals" must be validated for each customer application by customer's technical experts. SCILLC does not convey any license under its patent rights nor the rights of others. SCILLC products are not designed, intended, or authorized for use as components in systems intended for surgical implant into the body, or other applications intended to support or sustain life, or for any other application in which the failure of the SCILLC product could create a situation where personal injury or death may occur. Should Buyer purchase or use SCILLC products for any such unintended or unauthorized application, Buyer shall indemnify and hold SCILLC and its officers, employees, subsidiaries, affiliates, and distributors harmless against all claims, costs, damages, and expenses, and reasonable attorney fees arising out of, directly or indirectly, any claim of personal injury or death associated with such unintended or unauthorized use, even if such claim alleges that SCILLC was negligent regarding the design or manufacture of the part. SCILLC is an Equal Opportunity/Affirmative Action Employer. This literature is subject to all applicable copyright laws and is not for resale in any manner.

### PUBLICATION ORDERING INFORMATION

#### LITERATURE FULFILLMENT

Literature Distribution Center for ON Semiconductor  
P.O. Box 5163, Denver, Colorado 80217 USA  
Phone: 303-675-2175 or 800-344-3860 Toll Free USA/Canada  
Fax: 303-675-2176 or 800-344-3867 Toll Free USA/Canada  
Email: [orderlit@onsemi.com](mailto:orderlit@onsemi.com)

N. American Technical Support: 800-282-9855 Toll Free  
USA/Canada  
Europe, Middle East and Africa Technical Support:  
Phone: 421 33 790 2910  
Japan Customer Focus Center  
Phone: 81-3-5817-1050

ON Semiconductor Website: [www.onsemi.com](http://www.onsemi.com)

Order Literature: <http://www.onsemi.com/orderlit>

For additional information, please contact your local Sales Representative