

MC74HC4067A

Quad Analog Switch/ Multiplexer/Demultiplexer

High-Performance Silicon-Gate CMOS

The MC74HC4067A utilizes silicon-gate CMOS technology to achieve fast propagation delays, low ON resistances, and low OFF-channel leakage current. This bilateral switch/multiplexer/demultiplexer controls analog and digital voltages that may vary across the full power-supply range (from V_{CC} to GND).

The ON/OFF control inputs are compatible with standard CMOS outputs; with pullup resistors, they are compatible with LSTTL outputs. For analog switches with voltage-level translators, see the HC4316A.

Features

- Fast Switching and Propagation Speeds
- High ON/OFF Output Voltage Ratio
- Low Crosstalk Between Switches
- Diode Protection on All Inputs/Outputs
- Wide Power-Supply Voltage Range ($V_{CC} - GND$) = 2.0 to 6.0 V
- Analog Input Voltage Range ($V_{CC} - GND$) = 0 to 6.0 V
- Improved Linearity and Lower ON Resistance over Input Voltage
- Low Noise
- NLV Prefix for Automotive and Other Applications Requiring Unique Site and Control Change Requirements; AEC-Q100 Qualified and PPAP Capable
- These are Pb-Free Devices



ON Semiconductor®

www.onsemi.com

MARKING DIAGRAMS

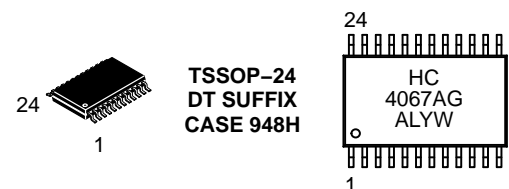
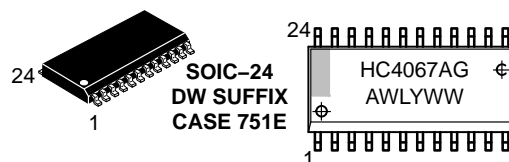

A = Assembly Location
L, WL = Wafer Lot
Y, YY = Year
W, WW = Work Week
G = Pb-Free Package

(Note: Microdot may be in either location)

ORDERING INFORMATION

See detailed ordering and shipping information in the package dimensions section on page 10 of this data sheet.

MC74HC4067A

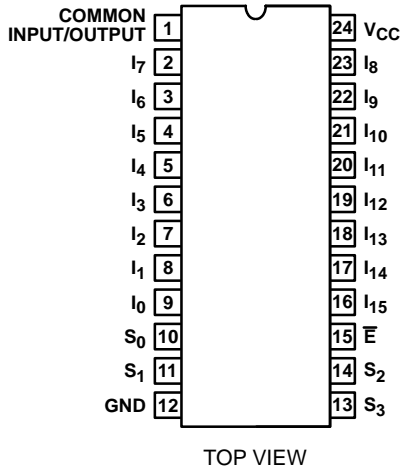

Figure 1. Pin Assignment

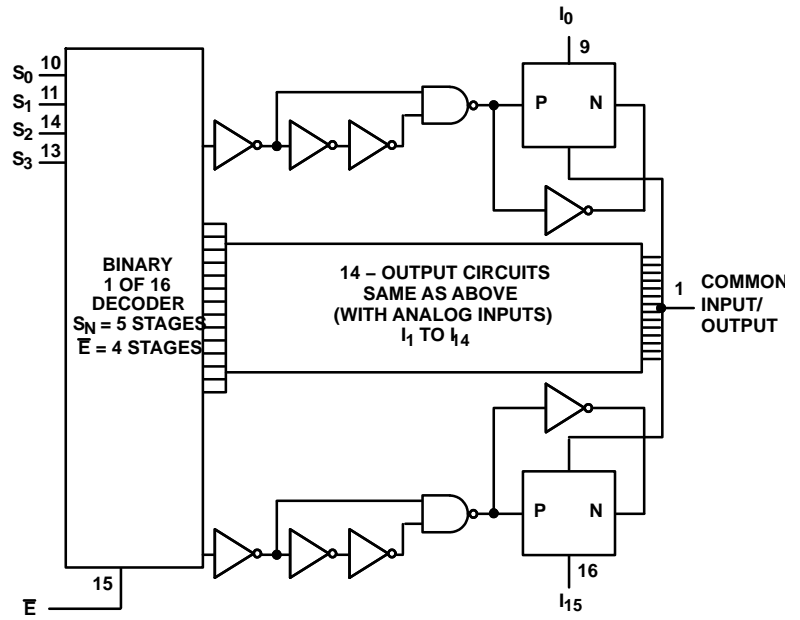

Figure 2. Function Diagram

TRUTH TABLE

S0	S1	S2	S3	\bar{E}	SELECTED CHANNEL
X	X	X	X	1	None
0	0	0	0	0	0
1	0	0	0	0	1
0	1	0	0	0	2
1	1	0	0	0	3
0	0	1	0	0	4
1	0	1	0	0	5
0	1	1	0	0	6
1	1	1	0	0	7
0	0	0	1	0	8
1	0	0	1	0	9
0	1	0	1	0	10
1	1	0	1	0	11
0	0	1	1	0	12
1	0	1	1	0	13
0	1	1	1	0	14
1	1	1	1	0	15

H= High Level
 L= Low Level
 X= Don't Care

MC74HC4067A

MAXIMUM RATINGS

Symbol	Parameter	Value	Unit	
V _{CC}	DC Supply Voltage	-0.5 to +7.0	V	
V _{IS}	Analog Input Voltage	-0.5 to V _{CC} + 0.5	V	
V _{IN}	Digital Input Voltage	-0.5 to V _{CC} + 0.5	V	
I _{IK}	Input Clamping Current	V _{IN} < -0.5 V or V _{IN} > V _{CC} + 0.5 V	±20	mA
I _{SK}	Switch Input Clamping Current	V _{IS} < -0.5 V or V _{IS} > V _{CC} + 0.5 V	±20	mA
I _{IS}	DC Switch Current		±25	mA
I _O	DC Output Source / Sink Current		±25	mA
I _{CC}	DC Supply Current per Supply Pin		±100	mA
I _{GND}	DC Ground Current per Ground Pin		±100	mA
T _{STG}	Storage Temperature Range		-65 to +150	°C
T _L	Lead Temperature, 1 mm from Case for 10 Seconds		260	°C
T _J	Junction Temperature under Bias		+150	°C
θ _{JA}	Thermal Resistance	SOIC TSSOP	97 148	°C/W
P _D	Power Dissipation in Still Air at 85°C	SOIC TSSOP	500 450	mW
MSL	Moisture Sensitivity		Level 1	
F _R	Flammability Rating	Oxygen Index: 30% – 35%	UL-94-VO (0.125 in)	
V _{ESD}	ESD Withstand Voltage	Human Body Model (Note 1) Machine Model (Note 2)	>3000 >200	V
I _{Latchup}	Latchup Performance	Above V _{CC} and Below GND at 85°C (Note 3)	±100	mA

Stresses exceeding Maximum Ratings may damage the device. Maximum Ratings are stress ratings only. Functional operation above the Recommended Operating Conditions is not implied. Extended exposure to stresses above the Recommended Operating Conditions may affect device reliability.

1. Tested to EIA/JESD22-A114-A.
2. Tested to EIA/JESD22-A115-A.
3. Tested to EIA/JESD78.

RECOMMENDED OPERATING CONDITIONS

Symbol	Parameter	Min	Max	Unit	
V _{CC}	Positive DC Supply Voltage (Referenced to GND)	2.0	6.0	V	
V _{IS}	Analog Input Voltage (Referenced to GND)	GND	V _{CC}	V	
V _{in}	Digital Input Voltage (Referenced to GND)	GND	V _{CC}	V	
V _{IO*}	Static or Dynamic Voltage Across Switch	-	1.2	V	
T _A	Operating Temperature, All Package Types	-55	+125	°C	
t _r , t _f	Input Rise and Fall Rate (Digital Inputs)	V _{CC} = 2.0 V V _{CC} = 3.0 V V _{CC} = 4.5 V V _{CC} = 6.0 V	0 0 0 0	1000 600 500 400	ns

Functional operation above the stresses listed in the Recommended Operating Ranges is not implied. Extended exposure to stresses beyond the Recommended Operating Ranges limits may affect device reliability.

*For voltage drops across the switch greater than 1.2 V (switch on), excessive V_{CC} current may be drawn; i.e., the current out of the switch may contain both V_{CC} and switch input components. The reliability of the device will be unaffected unless the Maximum Ratings are exceeded.

MC74HC4067A

DC ELECTRICAL CHARACTERISTIC Digital Section (Voltages Referenced to GND)

Symbol	Parameter	Conditions	V _{CC} (V)	Guaranteed Limit						Unit	
				25°C			-40 to 85°C		-55 to 125°C		
				Min	Typ	Max	Min	Max	Min		Max
V _{IH}	Minimum High-Level Input Voltage, Channel-Select or Enable Inputs		2.0	1.5			1.5			1.5	V
			3.0	2.1			2.1			2.1	
			4.5	3.15			3.15			3.15	
			6.0	4.2			4.2			4.2	
V _{IL}	Maximum Low-Level Input Voltage, Channel-Select or Enable Inputs		2.0			0.5		0.5		0.5	V
			3.0			0.9		0.9		0.9	
			4.5			1.35		1.35		1.35	
			6.0			1.8		1.8		1.8	
I _{IN}	Input Leakage Current, Control Inputs	V _{IN} = V _{CC} or GND	6.0			±0.1		±1.0		±1.0	μA
I _{CC}	Maximum Supply Current per Package	V _{IN} = V _{CC} or GND, I _O =0 V _{IS} = GND or V _{CC} , V _{OS} = V _{CC} or GND	6.0			4.0		40		80	μA
R _{ON}	ON Resistance	I _O = 1 mA V _{IN} = V _{CC} or GND, V _{IS} = V _{CC} or GND	4.5		70	160		200		240	Ω
			6.0		60	140		175		210	
R _{ON(peak)}	ON Resistance (peak)	I _O = 1 mA V _{IN} = V _{CC} to GND, V _{IS} = V _{CC} to GND	4.5		90	180		225		270	Ω
			6.0		80	160		200		240	
ΔR _{on}	ON Resistance Mismatch Between Any 2 Switches		4.5		10						Ω
			6.0		8.5						
I _{OFF}	OFF-State Leakage Current, All Channels	SW OFF, V _{IS} = V _{CC} or GND	6.0			±0.8		±8		±8	μA
I _{ON}	ON-State Leakage Current	SW OFF, V _{IS} = V _{CC} or GND	6.0			±0.8		±8		±8	μA

MC74HC4067A

AC CHARACTERISTICS (INPUT $t_r, t_f = 6$ ns)

Symbol	Parameter	Conditions	V_{CC} (V)	Guaranteed Limits						Unit	
				25°C			-40 to 85°C		-55 to 125°C		
				Min	Typ	Max	Min	Max	Min		Max
t_{PLH}, t_{PHL}	Propagation Delay Switch In to Out	$C_L = 50$ pF	2.0		75		95		110	ns	
			4.5		15		19		22		
		$C_L = 15$ pF	5.0	6.0							
t_{ON}	Switch Turn-ON Time									ns	
	E to Out	$C_L = 50$ pF	2.0		275		345		415		
			4.5		55		69		83		
			$C_L = 15$ pF	5.0	23						
	SN to Out	$C_L = 50$ pF	2.0		300		375		450		
4.5				60		75		90			
		$C_L = 15$ pF	5.0	25							
t_{OFF}	Switch Turn-OFF Time									ns	
	E to Out	$C_L = 50$ pF	2.0		275		345		415		
			4.5		55		69		83		
			$C_L = 15$ pF	5.0	23						
	SN to Out	$C_L = 50$ pF	2.0		290		365		435		
4.5				58		73		87			
		$C_L = 15$ pF	5.0	21							
C_{in}	Input Capacitance, Control Pins			3.5	10		10		10	pF	
C_{PD}	Power Dissipation Capacitance (Note 4)	$C_L = 15$ pF	5.0		29					pF	

4. C_{PD} is used to determine the dynamic power consumption, per multivibrator.

MC74HC4067A

ANALOG SWITCH CHANNEL CHARACTERISTICS

Symbol	Parameter	Conditions	V _{CC} (V)	Limit* 25°C	Unit
BW	Maximum On-Channel Bandwidth or Minimum Frequency Response	f _{in} = 1 MHz Sine Wave Adjust f _{in} Voltage to Obtain 0 dBm at V _{OS} Increase f _{in} Frequency Until dB Meter Reads - 3 dB R _L = 50 Ω, C _L = 10 pF	4.5	90	MHz
-	Off-Channel Feedthrough Isolation	f _{in} ≡ Sine Wave Adjust f _{in} Voltage to Obtain 0 dBm at V _{IS} f _{in} = 10 kHz, R _L = 600 Ω, C _L = 50 pF f _{in} = 1.0 MHz, R _L = 50 Ω, C _L = 10 pF	4.5 4.5	-65 -75	dB
-	Feedthrough Noise E, Sn to Switch	V _{in} ≤ 1 MHz Square Wave (t _r = t _f = 6 ns) Adjust R _L at Setup so that I _S = 0 A R _L = 600 Ω, C _L = 50 pF R _L = 10 kΩ, C _L = 10 pF	4.5 4.5	60 30	mV _{PP}
-	Crosstalk Between Any Two Switches	f _{in} ≡ Sine Wave Adjust f _{in} Voltage to Obtain 0 dBm at V _{IS} f _{in} = 10 kHz, R _L = 600 Ω, C _L = 50 pF f _{in} = 1.0 MHz, R _L = 50 Ω, C _L = 10 pF	4.5 4.5	-70 -80	dB
THD	Total Harmonic Distortion	f _{in} = 1 kHz, R _L = 10 kΩ, C _L = 50 pF THD = THD _{Measured} - THD _{Source} V _{IS} = 4.0 V _{PP} sine wave	4.5	0.04	%
C _S	Switch Input Capacitance			5	pF
C _{COM}	Switch Common Capacitance			45	pF

*Limits not tested. Determined by design and verified by qualification.

MC74HC4067A

TYPICAL CHARACTERISTICS

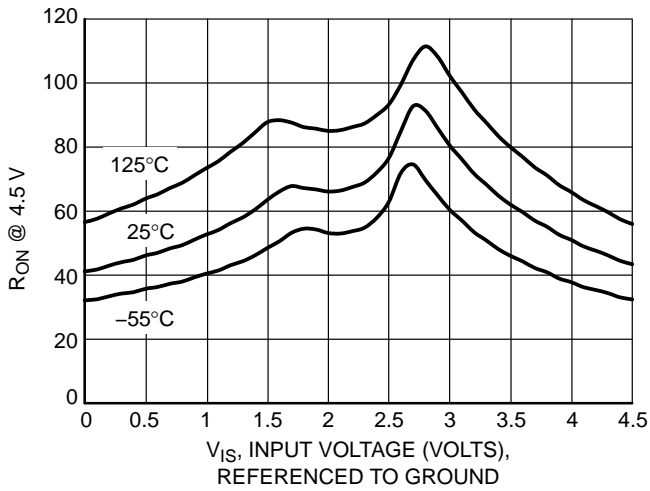

Figure 3. Typical On Resistance, $V_{CC} = 4.5\text{ V}$

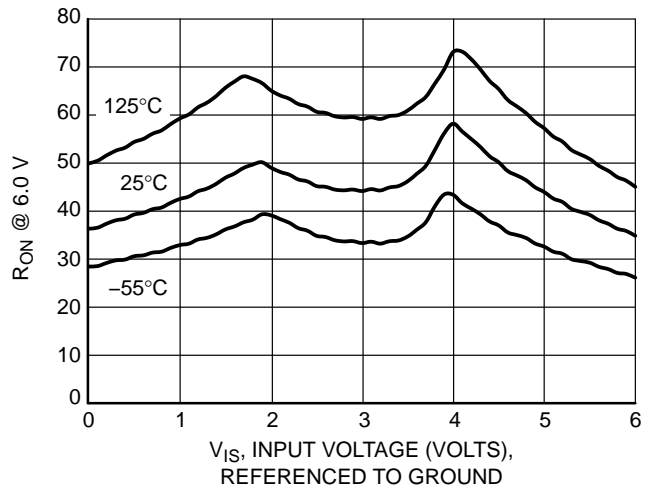

Figure 4. Typical On Resistance, $V_{CC} = 6.0\text{ V}$

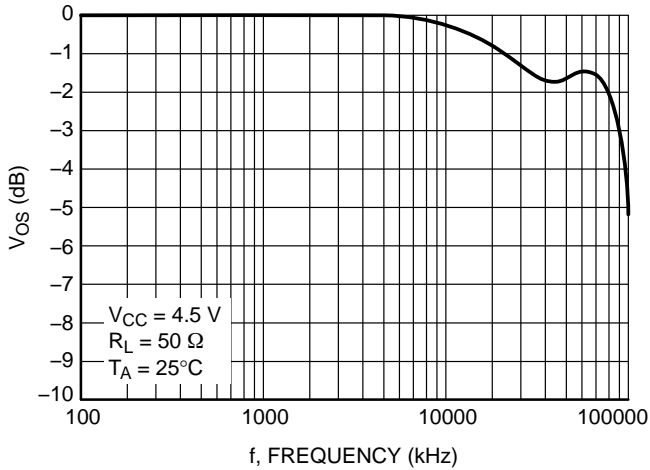

Figure 5. Typical Switch Frequency Response

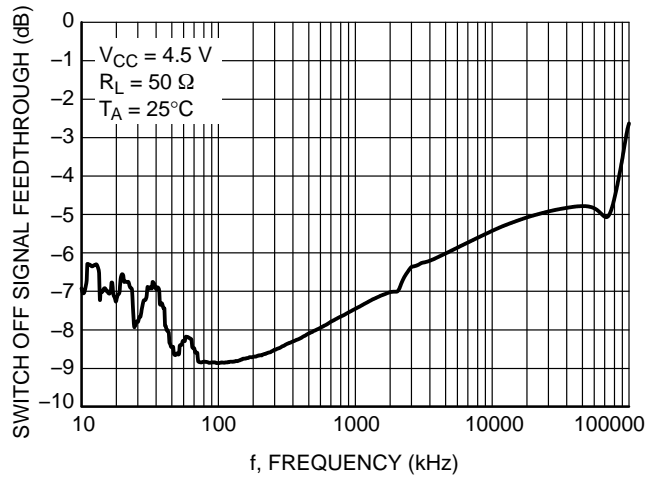

Figure 6. Typical Switch OFF Signal Feedthrough vs Frequency

MC74HC4067A

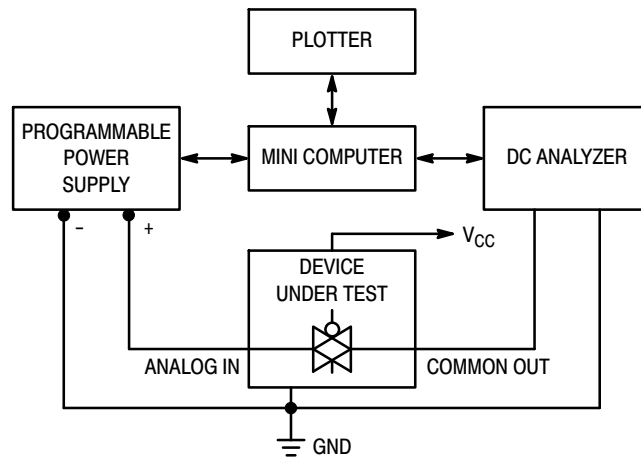

Figure 7. On Resistance Test Setup

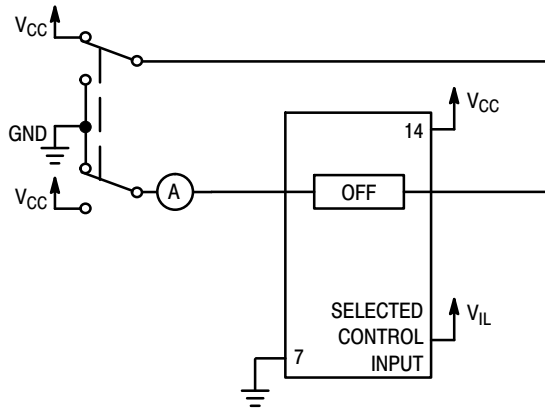

Figure 8. OFF Channel Leakage Current Test Setup, Any One Channel

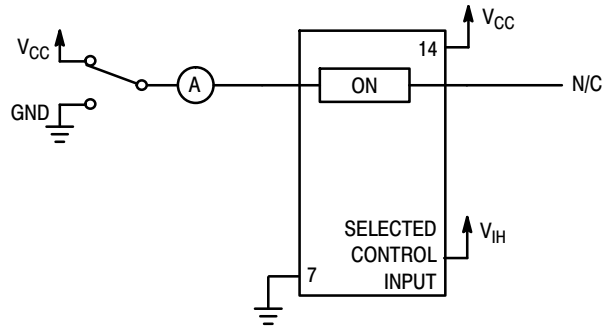

Figure 9. ON Channel Leakage Current Test Setup

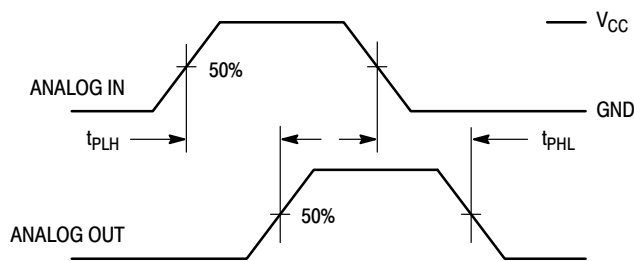
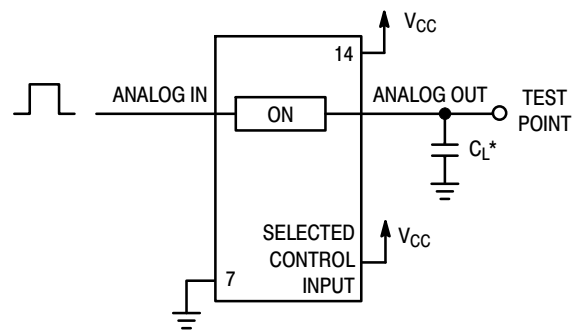

Figure 10. Propagation Delay, Analog In to Analog Out



*Includes all probe and jig capacitance.

Figure 11. Propagation Delay Test Setup

MC74HC4067A

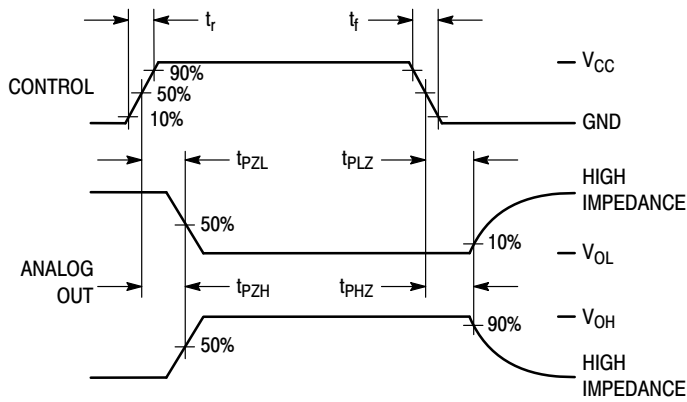
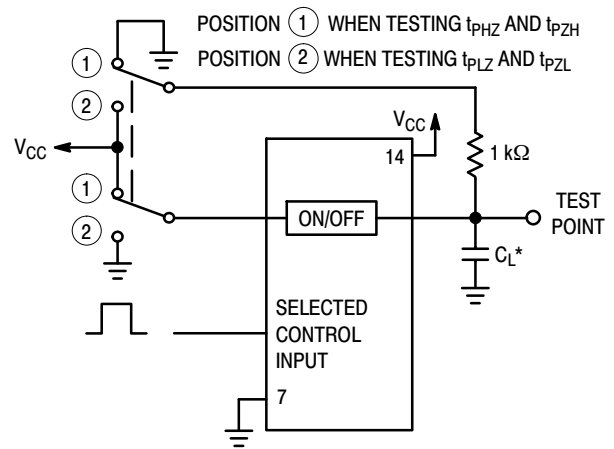

Figure 12. Turn-ON / Turn-OFF Times



*Includes all probe and jig capacitance.

Figure 13. Turn-ON / Turn-OFF Time Test Setup

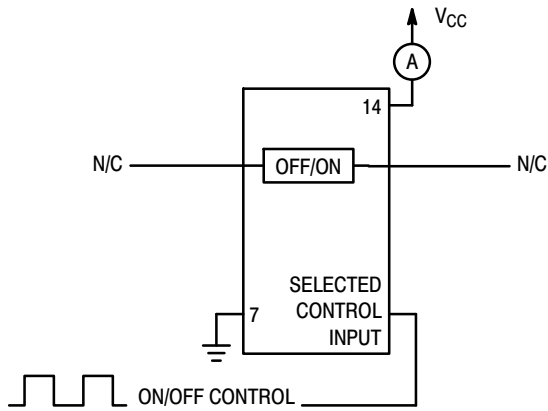
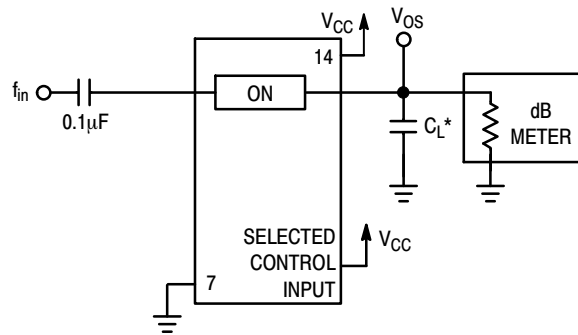
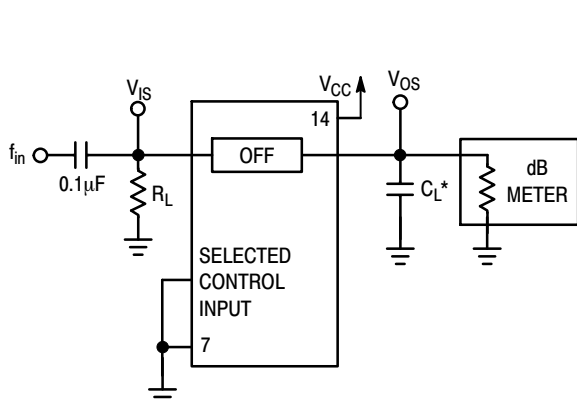

Figure 14. Power Dissipation Capacitance Test Setup



*Includes all probe and jig capacitance.

Figure 15. ON Channel Bandwidth Test Setup



*Includes all probe and jig capacitance.

Figure 16. OFF Channel Feedthrough Isolation Test Setup

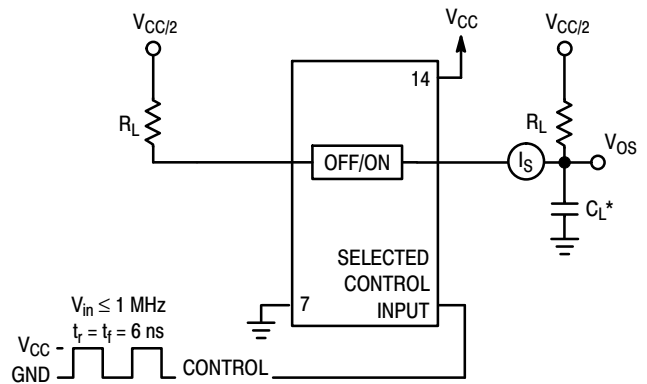

*Includes all probe and jig capacitance.

Figure 17. Feedthrough Noise Test Setup

MC74HC4067A

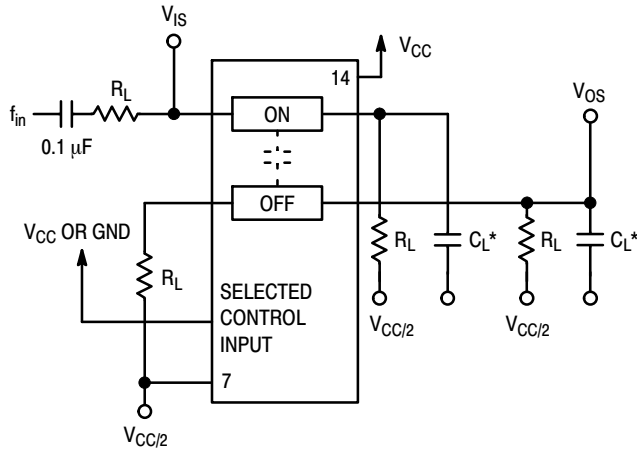

*Includes all probe and jig capacitance.

Figure 18. Crosstalk Between Any Two Switches Test Setup

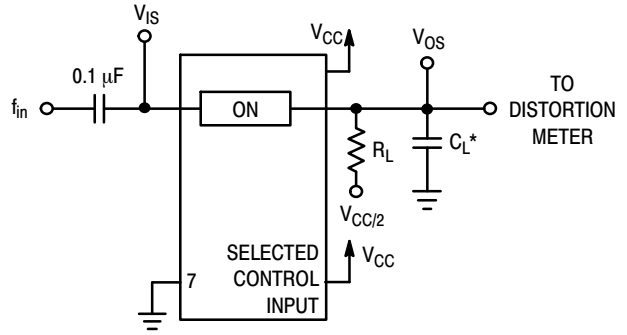

*Includes all probe and jig capacitance.

Figure 19. Total Harmonic Distortion Test Setup

ORDERING INFORMATION

Device	Package	Shipping [†]
MC74HC4067ADWG	SOIC-24 (Pb-Free)	30 Units / Tube
MC74HC4067ADWR2G	SOIC-24 (Pb-Free)	1000 / Tape & Reel
MC74HC4067ADTG	TSSOP-24 (Pb-Free)	62 Units / Tube
MC74HC4067ADTR2G	TSSOP-24 (Pb-Free)	2500 / Tape & Reel
NLV74HC4067ADTR2G*	TSSOP-24 (Pb-Free)	2500 / Tape & Reel

[†]For information on tape and reel specifications, including part orientation and tape sizes, please refer to our Tape and Reel Packaging Specifications Brochure, BRD8011/D.

*NLV Prefix for Automotive and Other Applications Requiring Unique Site and Control Change Requirements; AEC-Q100 Qualified and PPAP Capable.

MC74HC4067A

PACKAGE DIMENSIONS

SOIC-24 WB
CASE 751E-04
ISSUE F

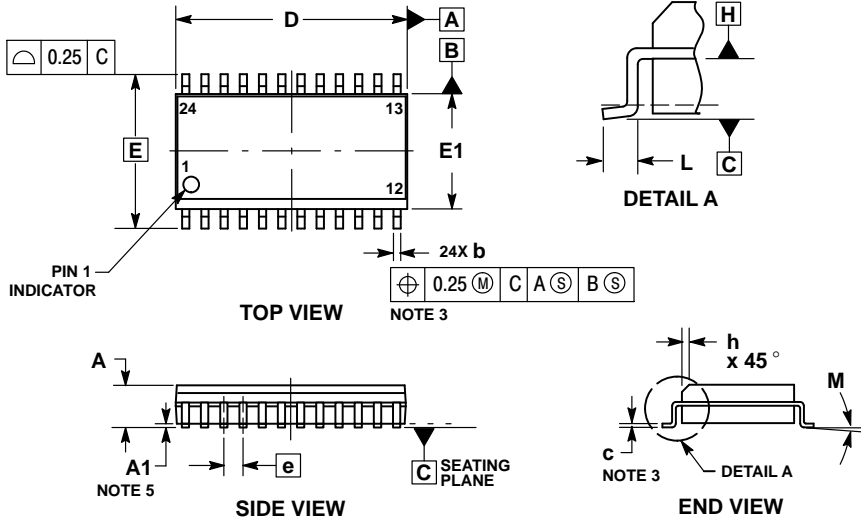

NOTES:

1. DIMENSIONING AND TOLERANCING PER ASME Y14.5M, 1994.
2. CONTROLLING DIMENSION: MILLIMETERS.
3. DIMENSIONS b AND c APPLY TO THE FLAT SECTION OF THE LEAD AND ARE MEASURED BETWEEN 0.10 AND 0.25 FROM THE LEAD TIP.
4. DIMENSIONS D AND E1 DO NOT INCLUDE MOLD FLASH, PROTRUSIONS OR GATE BURRS. MOLD FLASH, PROTRUSIONS OR GATE BURRS SHALL NOT EXCEED 0.15 mm PER SIDE. INTERLEAD FLASH OR PROTRUSION SHALL NOT EXCEED 0.25 PER SIDE. DIMENSIONS D AND E1 ARE DETERMINED AT DATUM H.
5. A1 IS DEFINED AS THE VERTICAL DISTANCE FROM THE SEATING PLANE TO THE LOWEST POINT ON THE PACKAGE BODY.

RECOMMENDED SOLDERING FOOTPRINT*

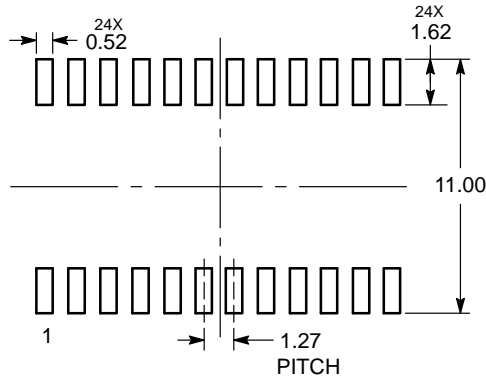

DIMENSIONS: MILLIMETERS

*For additional information on our Pb-Free strategy and soldering details, please download the ON Semiconductor Soldering and Mounting Techniques Reference Manual, SOLDERRM/D.

MC74HC4067A

PACKAGE DIMENSIONS

TSSOP24 7.8x4.4, 0.65P
CASE 948H
ISSUE B

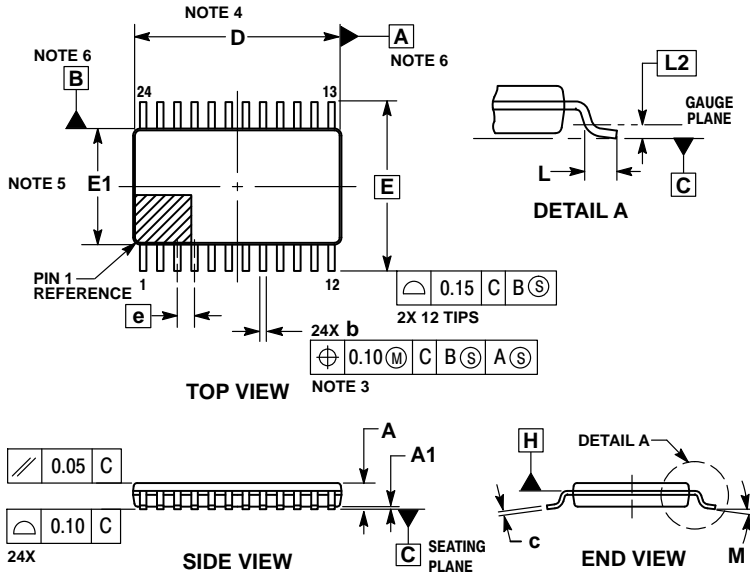

NOTES:

- DIMENSIONING AND TOLERANCING PER ASME Y14.5M, 1994.
- CONTROLLING DIMENSION: MILLIMETERS.
- DIMENSION b DOES NOT INCLUDE DAMBAR PROTRUSION. DAMBAR PROTRUSION SHALL BE 0.08 MAX AT MMC. DAMBAR CANNOT BE LOCATED ON THE LOWER RADIUS OF THE FOOT.
- DIMENSION D DOES NOT INCLUDE MOLD FLASH, PROTRUSIONS OR GATE BURRS. MOLD FLASH, PROTRUSIONS OR GATE BURRS SHALL NOT EXCEED 0.15 PER SIDE. DIMENSION D IS DETERMINED AT DATUM PLANE H.
- DIMENSION E1 DOES NOT INCLUDE INTERLEAD FLASH OR PROTRUSION. INTERLEAD FLASH OR PROTRUSION SHALL NOT EXCEED 0.25 PER SIDE. DIMENSION E1 IS DETERMINED AT DATUM PLANE H.
- DATUMS A AND B ARE DETERMINED AT DATUM PLANE H.
- A1 IS DEFINED AS THE VERTICAL DISTANCE FROM THE SEATING PLANE TO THE LOWEST POINT ON THE PACKAGE BODY.

SEATING PLANE TO THE LOWEST POINT ON THE PACKAGE BODY, MILLIMETERS		
DIM	MIN	MAX
A	---	1.20
A1	0.05	0.15
b	0.19	0.30
c	0.09	0.20
D	7.70	7.90
E	6.40 BSC	
E1	4.30	4.50
e	0.65 BSC	
L	0.50	0.75
L2	0.25 BSC	
M	0°	8°

RECOMMENDED SOLDERING FOOTPRINT

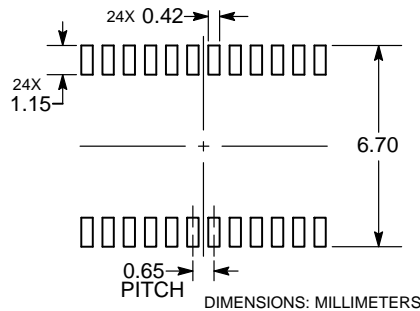

ON Semiconductor and the are registered trademarks of Semiconductor Components Industries, LLC (SCILLC) or its subsidiaries in the United States and/or other countries. SCILLC owns the rights to a number of patents, trademarks, copyrights, trade secrets, and other intellectual property. A listing of SCILLC's product/patent coverage may be accessed at www.onsemi.com/site/pdf/Patent-Marking.pdf. SCILLC reserves the right to make changes without further notice to any products herein. SCILLC makes no warranty, representation or guarantee regarding the suitability of its products for any particular purpose, nor does SCILLC assume any liability arising out of the application or use of any product or circuit, and specifically disclaims any and all liability, including without limitation special, consequential or incidental damages. "Typical" parameters which may be provided in SCILLC data sheets and/or specifications can and do vary in different applications and actual performance may vary over time. All operating parameters, including "Typicals" must be validated for each customer application by customer's technical experts. SCILLC does not convey any license under its patent rights nor the rights of others. SCILLC products are not designed, intended, or authorized for use as components in systems intended for surgical implant into the body, or other applications intended to support or sustain life, or for any other application in which the failure of the SCILLC product could create a situation where personal injury or death may occur. Should Buyer purchase or use SCILLC products for any such unintended or unauthorized application, Buyer shall indemnify and hold SCILLC and its officers, employees, subsidiaries, affiliates, and distributors harmless against all claims, costs, damages, and expenses, and reasonable attorney fees arising out of, directly or indirectly, any claim of personal injury or death associated with such unintended or unauthorized use, even if such claim alleges that SCILLC was negligent regarding the design or manufacture of the part. SCILLC is an Equal Opportunity/Affirmative Action Employer. This literature is subject to all applicable copyright laws and is not for resale in any manner.

PUBLICATION ORDERING INFORMATION

LITERATURE FULFILLMENT:

Literature Distribution Center for ON Semiconductor
P.O. Box 5163, Denver, Colorado 80217 USA
Phone: 303-675-2175 or 800-344-3860 Toll Free USA/Canada
Fax: 303-675-2176 or 800-344-3867 Toll Free USA/Canada
Email: orderlit@onsemi.com

N. American Technical Support: 800-282-9855 Toll Free USA/Canada
Europe, Middle East and Africa Technical Support: Phone: 421 33 790 2910
Japan Customer Focus Center Phone: 81-3-5817-1050

ON Semiconductor Website: www.onsemi.com

Order Literature: <http://www.onsemi.com/orderlit>

For additional information, please contact your local Sales Representative