

74VHC125

Quad Buffer with 3-STATE Outputs

Features

- High Speed: $t_{PD} = 3.8ns$ (Typ.) at $V_{CC} = 5V$
- Lower power dissipation: $I_{CC} = 4 \mu A$ (Max.) at $T_A = 25^\circ C$
- High noise immunity: $V_{NIH} = V_{NIL} = 28\% V_{CC}$ (Min.)
- Power down protection is provided on all inputs
- Low noise: $V_{OLP} = 0.8V$ (Max.)
- Pin and function compatible with 74HC125

General Description

The VHC125 contains four independent non-inverting buffers with 3-STATE outputs. It is an advanced high-speed CMOS device fabricated with silicon gate CMOS technology and achieves the high-speed operation similar to equivalent Bipolar Schottky TTL while maintaining the CMOS low power dissipation.

An input protection circuit insures that 0V to 7V can be applied to the input pins without regard to the supply voltage. This device can be used to interface 5V to 3V systems and two supply systems such as battery backup. This circuit prevents device destruction due to mismatched supply and input voltages.

Ordering Information

| Order Number | Package Number | Package Description |
|--------------|----------------|--|
| 74VHC125M | M14A | 14-Lead Small Outline Integrated Circuit (SOIC), JEDEC MS-012, 0.150" Narrow |
| 74VHC125SJ | M14D | 14-Lead Small Outline Package (SOP), EIAJ TYPE II, 5.3mm Wide |
| 74VHC125MTC | MTC14 | 14-Lead Thin Shrink Small Outline Package (TSSOP), JEDEC MO-153, 4.4mm Wide |

Device also available in Tape and Reel. Specify by appending suffix letter "X" to the ordering number.

 All packages are lead free per JEDEC: J-STD-020B standard.

Connection Diagram

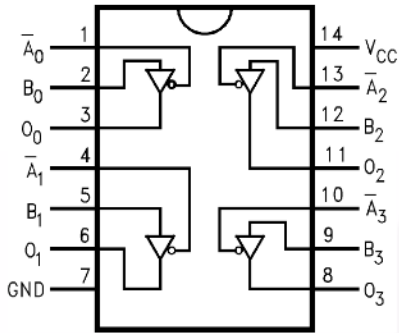

Logic Symbol

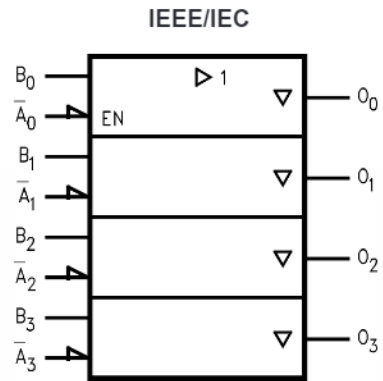

Pin Description

| Pin Names | Description |
|------------------|-------------|
| \bar{A}_n, B_n | Inputs |
| O_n | Outputs |

Function Table

| Inputs | | Output |
|-------------|-------|--------|
| \bar{A}_n | B_n | O_n |
| L | L | L |
| L | H | H |
| H | X | Z |

H = HIGH Voltage Level
 L = LOW Voltage Level
 Z = HIGH Impedance
 X = Immaterial

Absolute Maximum Ratings

Stresses exceeding the absolute maximum ratings may damage the device. The device may not function or be operable above the recommended operating conditions and stressing the parts to these levels is not recommended. In addition, extended exposure to stresses above the recommended operating conditions may affect device reliability. The absolute maximum ratings are stress ratings only.

| Symbol | Parameter | Rating |
|-----------|--|--------------------------|
| V_{CC} | Supply Voltage | -0.5V to +7.0V |
| V_{IN} | DC Input Voltage | -0.5V to +7.0V |
| V_{OUT} | DC Output Voltage | -0.5V to $V_{CC} + 0.5V$ |
| I_{IK} | Input Diode Current | -20mA |
| I_{OK} | Output Diode Current | ±20mA |
| I_{OUT} | DC Output Current | ±25mA |
| I_{CC} | DC V_{CC} / GND Current | ±50mA |
| T_{STG} | Storage Temperature | -65°C to +150°C |
| T_L | Lead Temperature (Soldering, 10 seconds) | 260°C |

Recommended Operating Conditions⁽¹⁾

The Recommended Operating Conditions table defines the conditions for actual device operation. Recommended operating conditions are specified to ensure optimal performance to the datasheet specifications. Fairchild does not recommend exceeding them or designing to absolute maximum ratings.

| Symbol | Parameter | Rating |
|------------|---|-----------------------------------|
| V_{CC} | Supply Voltage | 2.0V to +5.5V |
| V_{IN} | Input Voltage | 0V to +5.5V |
| V_{OUT} | Output Voltage | 0V to V_{CC} |
| T_{OPR} | Operating Temperature | -40°C to +85°C |
| t_r, t_f | Input Rise and Fall Time, $V_{CC} = 3.3V \pm 0.3V$ $V_{CC} = 5.0V \pm 0.5V$ | 0ns/V ~ 100ns/V 0ns/V ~ 20ns/V |

Note:

- Unused inputs must be held HIGH or LOW. They may not float.

DC Electrical Characteristics

| Symbol | Parameter | V _{CC} (V) | Conditions | T _A = | | | | | Units | |
|-----------------|----------------------------------|---------------------|---|-------------------------|-----------------------|-----------------------|-----------------------|------|-------|---|
| | | | | 25°C | | | -40°C to +85°C | | | |
| | | | | Min. | Typ. | Max. | Min. | Max. | | |
| V _{IH} | HIGH Level Input Voltage | 2.0 | | 1.50 | | | 1.50 | | V | |
| | | 3.0–5.5 | | 0.7 x V _{CC} | | 0.7 x V _{CC} | | | | |
| V _{IL} | LOW Level Input Voltage | 2.0 | | | | 0.50 | | 0.50 | V | |
| | | 3.0–5.5 | | | 0.3 x V _{CC} | | 0.3 x V _{CC} | | | |
| V _{OH} | HIGH Level Output Voltage | 2.0 | V _{IN} = V _{IH} or V _{IL} | I _{OH} = -50μA | 1.9 | 2.0 | | 1.9 | | V |
| | | 3.0 | | | 2.9 | 3.0 | | 2.9 | | |
| | | 4.5 | | | 4.4 | 4.5 | | 4.4 | | |
| | | 3.0 | | I _{OH} = -4mA | 2.58 | | | 2.48 | | |
| | | 4.5 | | I _{OH} = -8mA | 3.94 | | | 3.80 | | |
| V _{OL} | LOW Level Output Voltage | 2.0 | V _{IN} = V _{IH} or V _{IL} | I _{OL} = 50μA | | 0.0 | 0.1 | | 0.1 | V |
| | | 3.0 | | | | 0.0 | 0.1 | | 0.1 | |
| | | 4.5 | | | | 0.0 | 0.1 | | 0.1 | |
| | | 3.0 | | I _{OL} = 4mA | | | 0.36 | | 0.44 | |
| | | 4.5 | | I _{OL} = 8mA | | | 0.36 | | 0.44 | |
| I _{OZ} | 3-STATE Output Off-State Current | 5.5 | V _{IN} = V _{IH} or V _{IL} , V _{OUT} = V _{CC} or GND | | | ±0.25 | | ±2.5 | μA | |
| I _{IN} | Input Leakage Current | 0–5.5 | V _{IN} = 5.5V or GND | | | ±0.1 | | ±1.0 | μA | |
| I _{CC} | Quiescent Supply Current | 5.5 | V _{IN} = V _{CC} or GND | | | 4.0 | | 40.0 | μA | |

Noise Characteristics

| Symbol | Parameter | V _{CC} (V) | Conditions | T _A = 25°C | | Units |
|---------------------------------|--|---------------------|-----------------------|-----------------------|--------|-------|
| | | | | Typ. | Limits | |
| V _{OLP} ⁽²⁾ | Quiet Output Maximum Dynamic V _{OL} | 5.0 | C _L = 50pF | 0.5 | 0.8 | V |
| V _{OLV} ⁽²⁾ | Quiet Output Minimum Dynamic V _{OL} | 5.0 | C _L = 50pF | -0.5 | -0.8 | V |
| V _{IHD} ⁽²⁾ | Minimum HIGH Level Dynamic Input Voltage | 5.0 | C _L = 50pF | | 3.5 | V |
| V _{ILD} ⁽²⁾ | Maximum HIGH Level Dynamic Input Voltage | 5.0 | C _L = 50pF | | 1.5 | V |

Note:

2. Parameter guaranteed by design.

AC Electrical Characteristics

| Symbol | Parameter | V _{CC} (V) | Conditions | T _A = 25°C | | | T _A = -40°C to +85°C | | Units |
|---------------------------------------|-------------------------------|---------------------|------------------------|-----------------------|------|------|---------------------------------|------|-------|
| | | | | Min. | Typ. | Max. | Min. | Max. | |
| t _{PLH} , t _{PHL} | Propagation Delay Time | 3.3 ± 0.3 | R _L = 1kΩ | C _L = 15pF | 5.6 | 8.0 | 1.0 | 9.5 | ns |
| | | | | C _L = 50pF | 8.1 | 11.5 | 1.0 | 13.0 | |
| | | 5.0 ± 0.5 | | C _L = 15pF | 3.8 | 5.5 | 1.0 | 6.5 | ns |
| | | | | C _L = 50pF | 5.3 | 7.5 | 1.0 | 8.5 | |
| t _{PZL} , t _{PZH} | 3-STATE Output Enable Time | 3.3 ± 0.3 | R _L = 1kΩ | C _L = 15pF | 5.4 | 8.0 | 1.0 | 9.5 | ns |
| | | | | C _L = 50pF | 7.9 | 11.5 | 1.0 | 13.0 | |
| | | 5.0 ± 0.5 | | C _L = 15pF | 3.6 | 5.1 | 1.0 | 6.0 | ns |
| | | | | C _L = 50pF | 5.1 | 7.1 | 1.0 | 8.0 | |
| t _{PLZ} , t _{PHZ} | 3-STATE Output Disable Time | 3.3 ± 0.3 | R _L = 1kΩ | C _L = 50pF | 9.5 | 13.2 | 1.0 | 15.0 | ns |
| | | 5.0 ± 0.5 | | C _L = 50pF | 6.1 | 8.8 | 1.0 | 10.0 | |
| t _{OSLH} , t _{OSHL} | Output to Output Skew | 3.3 ± 0.3 | ⁽³⁾ | C _L = 50pF | | 1.5 | | 1.5 | ns |
| | | 5.0 ± 0.5 | | C _L = 50pF | | 1.0 | | 1.0 | |
| C _{IN} | Input Capacitance | | V _{CC} = Open | | 4 | 10 | | 10 | pF |
| C _{OUT} | Output Capacitance | | V _{CC} = 5.0V | | 6 | | | | pF |
| C _{PD} | Power Dissipation Capacitance | | ⁽⁴⁾ | | 14 | | | | pF |

Notes:

- Parameter guaranteed by design. $t_{OSLH} = |t_{PLHmax} - t_{PLHmin}|$; $t_{OSHL} = |t_{PHLmax} - t_{PHLmin}|$.
- C_{PD} is defined as the value of the internal equivalent capacitance which is calculated from the operating current consumption without load. Average operating current can be obtained by the equation:
I_{CC} (Opr.) = C_{PD} • V_{CC} • f_{IN} + I_{CC} / 4 (per bit).

Physical Dimensions

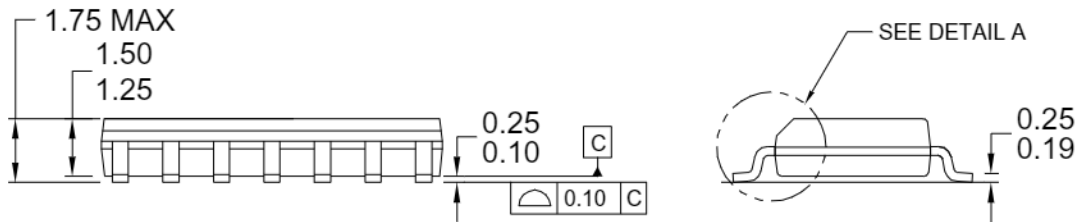
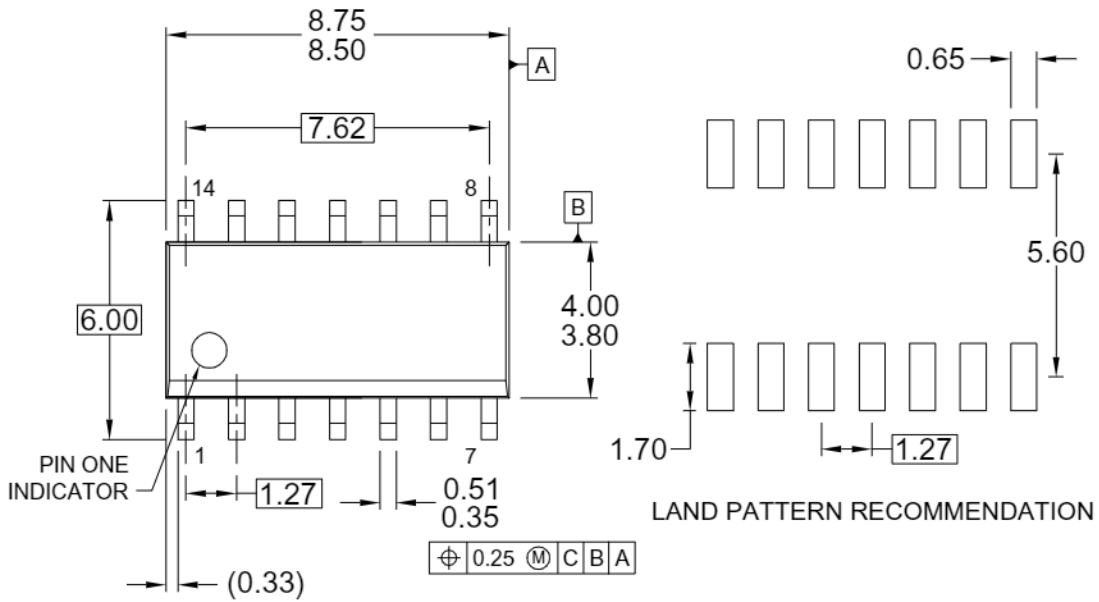

NOTES: UNLESS OTHERWISE SPECIFIED

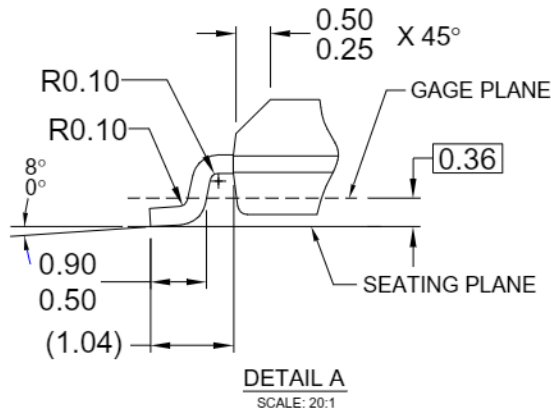

- A) THIS PACKAGE CONFORMS TO JEDEC MS-012, VARIATION AB, ISSUE C,
- B) ALL DIMENSIONS ARE IN MILLIMETERS.
- C) DIMENSIONS DO NOT INCLUDE MOLD FLASH OR BURRS.
- D) LANDPATTERN STANDARD: SOIC127P600X145-14M
- E) DRAWING CONFORMS TO ASME Y14.5M-1994
- F) DRAWING FILE NAME: M14AREV13

Figure 1. 14-Lead Small Outline Integrated Circuit (SOIC), JEDEC MS-012, 0.150" Narrow

Package drawings are provided as a service to customers considering Fairchild components. Drawings may change in any manner without notice. Please note the revision and/or date on the drawing and contact a Fairchild Semiconductor representative to verify or obtain the most recent revision. Package specifications do not expand the terms of Fairchild's worldwide terms and conditions, specifically the warranty therein, which covers Fairchild products.

Always visit Fairchild Semiconductor's online packaging area for the most recent package drawings:

<http://www.fairchildsemi.com/packaging/>

Physical Dimensions (Continued)

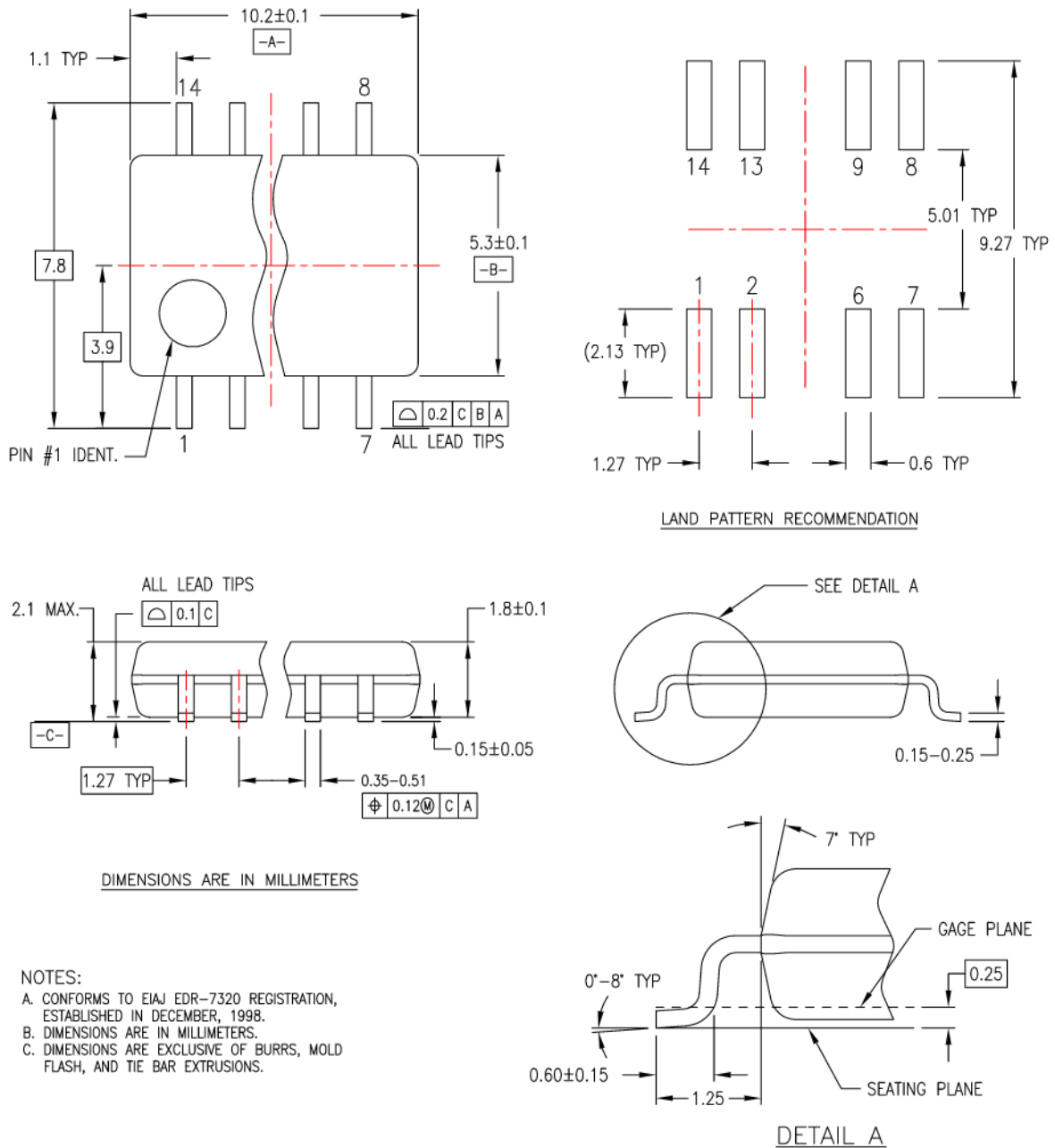

M14DREVC

Figure 2. 14-Lead Small Outline Package (SOP), EIAJ TYPE II, 5.3mm Wide

Package drawings are provided as a service to customers considering Fairchild components. Drawings may change in any manner without notice. Please note the revision and/or date on the drawing and contact a Fairchild Semiconductor representative to verify or obtain the most recent revision. Package specifications do not expand the terms of Fairchild's worldwide terms and conditions, specifically the warranty therein, which covers Fairchild products.

Always visit Fairchild Semiconductor's online packaging area for the most recent package drawings:

<http://www.fairchildsemi.com/packaging/>

Physical Dimensions (Continued)

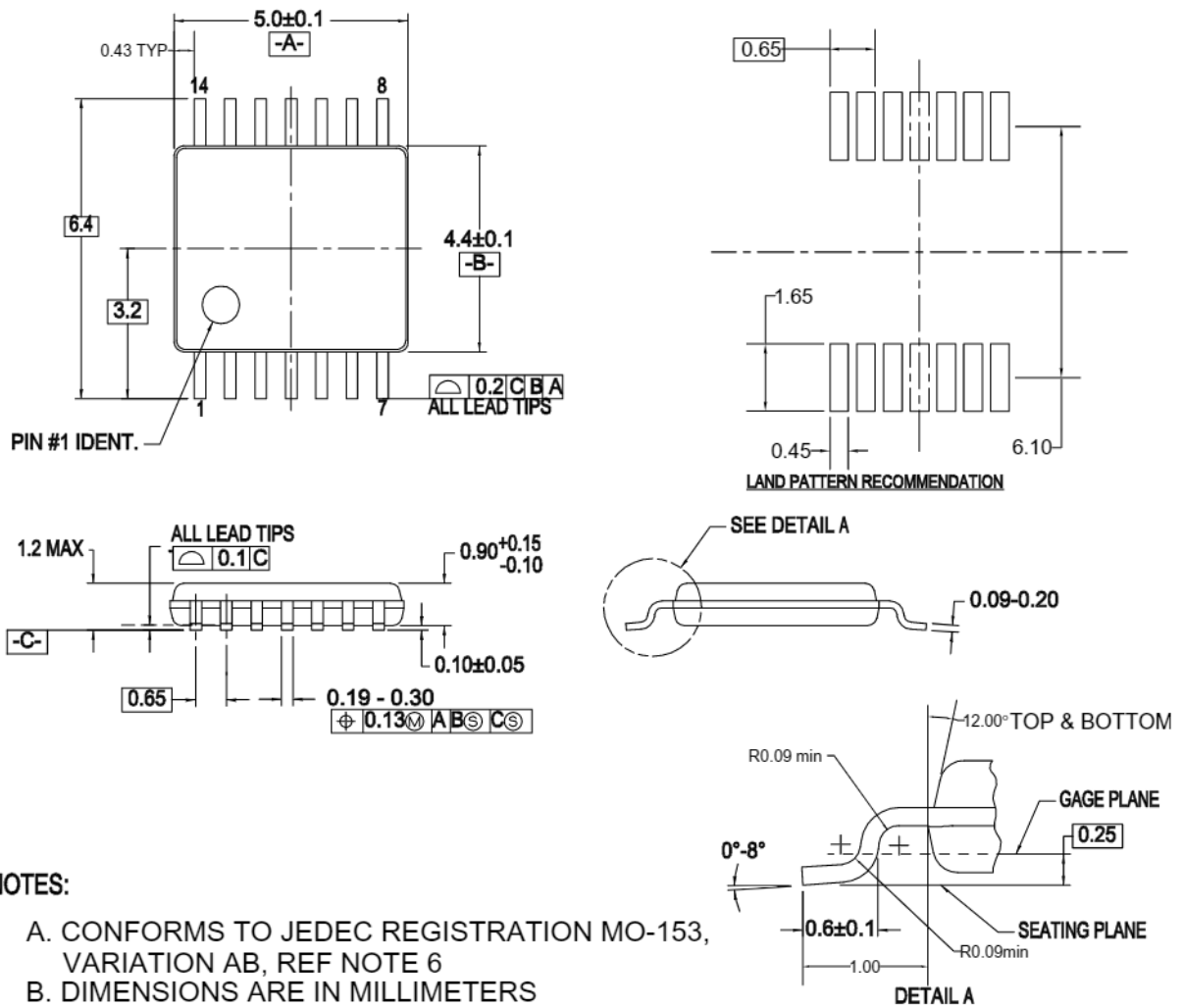

NOTES:

- A. CONFORMS TO JEDEC REGISTRATION MO-153, VARIATION AB, REF NOTE 6
- B. DIMENSIONS ARE IN MILLIMETERS
- C. DIMENSIONS ARE EXCLUSIVE OF BURRS, MOLD FLASH, AND TIE BAR EXTRUSIONS
- D. DIMENSIONING AND TOLERANCES PER ANSI Y14.5M, 1982
- E. LANDPATTERN STANDARD: SOP65P640X110-14M
- F. DRAWING FILE NAME: MTC14REV6

Figure 3. 14-Lead Thin Shrink Small Outline Package (TSSOP), JEDEC MO-153, 4.4mm Wide

Package drawings are provided as a service to customers considering Fairchild components. Drawings may change in any manner without notice. Please note the revision and/or date on the drawing and contact a Fairchild Semiconductor representative to verify or obtain the most recent revision. Package specifications do not expand the terms of Fairchild's worldwide terms and conditions, specifically the warranty therein, which covers Fairchild products.



Always visit Fairchild Semiconductor's online packaging area for the most recent package drawings:

<http://www.fairchildsemi.com/packaging/>



TRADEMARKS

The following includes registered and unregistered trademarks and service marks, owned by Fairchild Semiconductor and/or its global subsidiaries, and is not intended to be an exhaustive list of all such trademarks.

| | | | |
|--|--|--|---|
| ACEx [®] | FPS [™] | PDP-SPM [™] | SyncFET [™] |
| Build it Now [™] | FRFET [®] | Power220 [®] |  SYSTEM GENERAL [®] |
| CorePLUS [™] | Global Power Resource SM | Power247 [®] | The Power Franchise [®] |
| CROSSVOLT [™] | Green FPS [™] | POWEREDGE [®] | the power [™] |
| CTL [™] | Green FPS [™] e-Series [™] | Power-SPM [™] | franchise |
| Current Transfer Logic [™] | GTO [™] | PowerTrench [®] | TinyBoost [™] |
| EcoSPARK [®] | <i>i-Lo</i> [™] | Programmable Active Droop [™] | TinyBuck [™] |
| EZSWITCH [™] * | IntelliMAX [™] | QFET [®] | TinyLogic [®] |
|  [™] | ISOPLANAR [™] | QS [™] | TINYOPTO [™] |
|  [®] | MegaBuck [™] | QT Optoelectronics [™] | TinyPower [™] |
| Fairchild [®] | MICROCOUPLER [™] | Quiet Series [™] | TinyPWM [™] |
| Fairchild Semiconductor [®] | MicroFET [™] | RapidConfigure [™] | TinyWire [™] |
| FACT Quiet Series [™] | MicroPak [™] | SMART START [™] | μSerDes [™] |
| FACT [®] | MillerDrive [™] | SPM [®] | UHC [®] |
| FAST [®] | Motion-SPM [™] | STEALTH [™] | Ultra FRFET [™] |
| FastvCore [™] * | OPTOLOGIC [®] | SuperFET [™] | UniFET [™] |
| FlashWriter [®] * | OPTOPLANAR [®] | SuperSOT [™] -3 | VCX [™] |
| | | SuperSOT [™] -6 | |
| | | SuperSOT [™] -8 | |

* EZSWITCH[™] and FlashWriter[®] are trademarks of System General Corporation, used under license by Fairchild Semiconductor.

DISCLAIMER

FAIRCHILD SEMICONDUCTOR RESERVES THE RIGHT TO MAKE CHANGES WITHOUT FURTHER NOTICE TO ANY PRODUCTS HEREIN TO IMPROVE RELIABILITY, FUNCTION, OR DESIGN. FAIRCHILD DOES NOT ASSUME ANY LIABILITY ARISING OUT OF THE APPLICATION OR USE OF ANY PRODUCT OR CIRCUIT DESCRIBED HEREIN; NEITHER DOES IT CONVEY ANY LICENSE UNDER ITS PATENT RIGHTS, NOR THE RIGHTS OF OTHERS. THESE SPECIFICATIONS DO NOT EXPAND THE TERMS OF FAIRCHILD'S WORLDWIDE TERMS AND CONDITIONS, SPECIFICALLY THE WARRANTY THEREIN, WHICH COVERS THESE PRODUCTS.

LIFE SUPPORT POLICY

FAIRCHILD'S PRODUCTS ARE NOT AUTHORIZED FOR USE AS CRITICAL COMPONENTS IN LIFE SUPPORT DEVICES OR SYSTEMS WITHOUT THE EXPRESS WRITTEN APPROVAL OF FAIRCHILD SEMICONDUCTOR CORPORATION.

As used herein:

1. Life support devices or systems are devices or systems which, (a) are intended for surgical implant into the body or (b) support or sustain life, and (c) whose failure to perform when properly used in accordance with instructions for use provided in the labeling, can be reasonably expected to result in a significant injury of the user.
2. A critical component in any component of a life support, device, or system whose failure to perform can be reasonably expected to cause the failure of the life support device or system, or to affect its safety or effectiveness.

PRODUCT STATUS DEFINITIONS

Definition of Terms

| Datasheet Identification | Product Status | Definition |
|--------------------------|------------------------|--|
| Advance Information | Formative or In Design | This datasheet contains the design specifications for product development. Specifications may change in any manner without notice. |
| Preliminary | First Production | This datasheet contains preliminary data; supplementary data will be published at a later date. Fairchild Semiconductor reserves the right to make changes at any time without notice to improve design. |
| No Identification Needed | Full Production | This datasheet contains final specifications. Fairchild Semiconductor reserves the right to make changes at any time without notice to improve the design. |
| Obsolete | Not In Production | This datasheet contains specifications on a product that has been discontinued by Fairchild Semiconductor. The datasheet is printed for reference information only. |

Rev. I32