

LC709511F

Power Bank Controller with USB Type-C & Quick Charge™ 3.0 for 1-Cell Li-Ion and Li-Poly Battery

Overview

LC709511F is a Lithium ion switching charger controller for Power Bank. This device has all functions to control Power Bank application. It includes Type-C port control, Quick Charge 3.0 HVDCP and Smart switch. The built-in switching controller can output from 5 V up to 12 V for Quick Charge. The high power output for USB Type-C and Quick Charge is possible with appropriate external MOSFETs.

Features

- Easy Power Scaling with External MOSFETs
- Buck Charge to Built-in Battery/Boost Charge to USB Devices
- Supports Quick Charge 3.0 HVDCP Class A. 5 V up to 12 V
- Supports USB Type-C Dual Role without External Port Control IC
- Smart Switch Applies 2.7 V or 2.0 V or DCP Short on USB Data Lines Automatically for Requirement of USB Devices
- Reference Software Supports Various Combination of USB Port
- Supports USB BC1.2
- Controls an External Boost-IC for 2nd USB Output
- Battery Level Gauging
- Status & Battery Level Display with 4 LEDs
- Boost Auto Start-up
- Thermistor Sensing Function
- Over Voltage/Over Current Detection
- JEITA Compliance Battery Management
- Safety Timer
- Low Quiescent Current: 15 μ A at Low Power Mode
- These Devices are Pb-Free, Halogen Free/BFR Free and are RoHS Compliant

Applications

- Power Bank
- USB-related Charging Application



ON Semiconductor®

www.onsemi.com

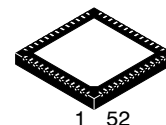

QFN52 6x6, 04P
CASE 485BE

MARKING DIAGRAM

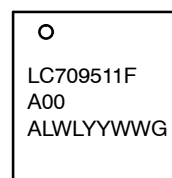

LC709511FA00 = Specific Device Code
AL = Assembly Location
WL = Wafer Lot
YY = Year
WW = Work Week
G = Pb-Free Package

ORDERING INFORMATION

Device	Package	Shipping†
LC709511FQD-A00TWG	QFN52 (Pb-Free/ Halogen Free)	3,000 / Tape & Reel

†For information on tape and reel specifications, including part orientation and tape sizes, please refer to our Tape and Reel Packaging Specification Brochure, BRD8011/D.

LC709511F

PIN ASSIGNMENT

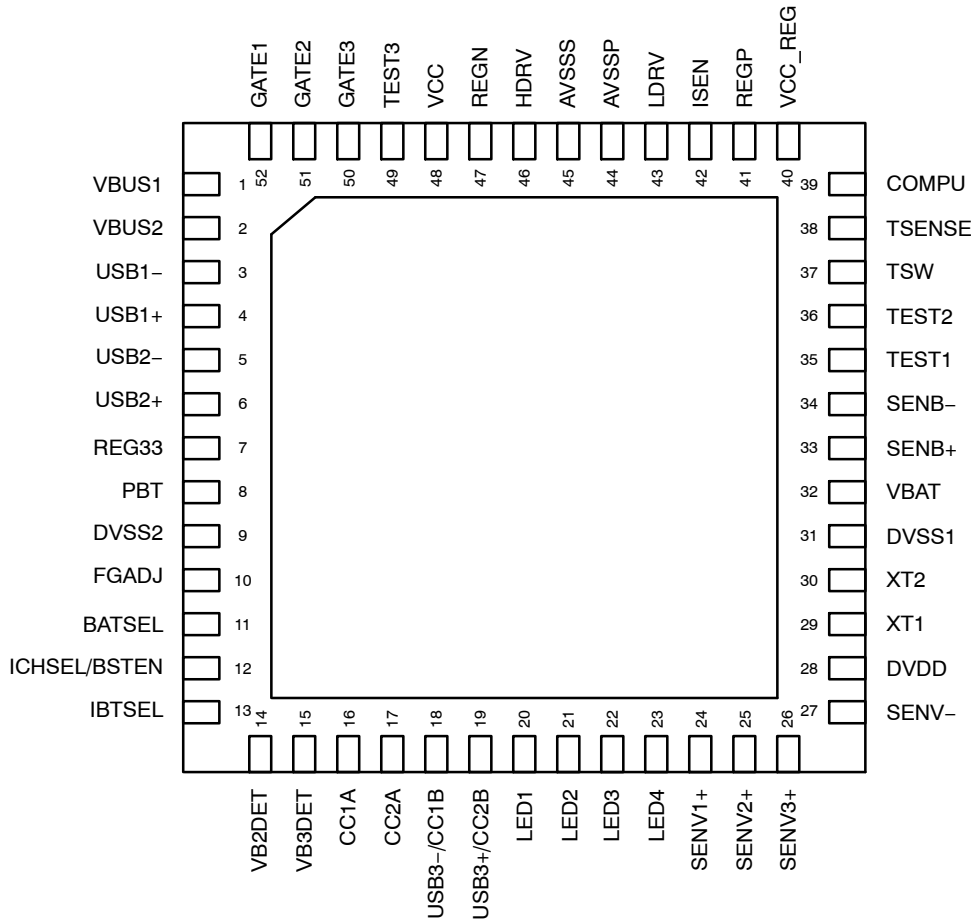

Figure 1. Pin Assignment (Top View)

PIN FUNCTION

Pin No.	Pin Name	I/O	Description
1	VBUS1	I	Connect this pin to the VBUS of Micro B (sink) or Type-C
2	VBUS2	I	Keep this pin OPEN
3	USB1-	I/O	USB D- data line input. Connect this pin to USB Host/Charging port to detect USB port (BC1.2, dedicated charger)
4	USB1+	I/O	USB D+ data line input. Connect this pin to USB Host/Charging port to detect USB port (BC1.2, dedicated charger)
5	USB2-	I/O	USB D- data line output. Connect this pin to Portable USB devices Supports Quick Charge 3.0 HVDCP
6	USB2+	I/O	USB D+ data line output. Connect this pin to Portable USB devices Supports Quick Charge 3.0 HVDCP
7	REG33	-	Connect this pin and a capacitor
8	PBT	I	Push button input
9	DVSS2	-	Connect this pin to GND
10	FGADJ	I	Sets the design capacity of a battery for Port configuration. Pull down this pin to GND through a resistor. In Software configuration keep this pin OPEN
11	BATSEL	-	Keep this pin OPEN

LC709511F

PIN FUNCTION (continued)

Pin No.	Pin Name	I/O	Description
12	ICHSEL/BSTEN	O	An external Boost-IC control. This pin is set to "HIGH" when it outputs to VBUS of Type-A (2)
13	IBTSEL	-	Keep this pin OPEN
14	VB2DET	I	Detects VBUS voltage and attached and unattached of USB2 port
15	VB3DET	I	Detects VBUS voltage and attached and unattached of USB3 port
16	CC1A	I/O	FW05: Configuration Channel (CC1) pin for Type-C. It outputs Rp or Rd, and detects attached and unattached
17	CC2A	I/O	FW05: Configuration Channel (CC2) pin for Type-C. It outputs Rp or Rd, and detects attached and unattached
18	USB3-/CC1B	I/O	FW02: USB D- data line output. Supports DCP and Divided mode. This pin switch the output automatically to be optimal for connected device
19	USB3+/CC2B	I/O	FW02: USB D+ data line output. Supports DCP and Divided mode. This pin switch the output automatically to be optimal for connected device
20	LED1	O	Displays battery level. This is an open drain pin
21	LED2	O	Displays battery level. This is an open drain pin
22	LED3	O	Displays battery level. This is an open drain pin
23	LED4	O	Displays battery level. This is an open drain pin
24	SENV1+	I	Connect this pin to positive terminal of sense resistor to detect the current when the Reference software is FW05
25	SENV2+	I	Connect this pin to positive terminal of sense resistor to detect Type-A (1) output current
26	SENV3+	I	Connect this pin to positive terminal of sense resistor to detect Type-A (2) output current
27	SENV-	I	Connect this pin to negative terminal of sense resistor to detect the current
28	DVDD	-	Digital power supply. Connect this pin to REGP through a schottky diode
29	XT1	I	Keep this pin OPEN
30	XT2	O	Keep this pin OPEN
31	DVSS1	-	Connects this pin to GND
32	VBAT	I	Connect this pin to positive pin of a battery
33	SENB+	I	Connect this pin to positive terminal of sense resistor to detect battery current
34	SENB-	I	Connect this pin to negative terminal of sense resistor to detect battery current
35	TEST1	I	Connect this pin to GND
36	TEST2	I	Keep this pin OPEN
37	TSW	O	Power supply output for thermistor. This pin is set to "HIGH" when reading the temperature. Resistance value of TSW (for thermistor pull-up) must be the same value as the thermistor at 25°C
38	TSENSE	I	Thermistor sense input. Use 100 Ω resistor when connecting this pin to a thermistor
39	COMPU	-	Connect this pin to a capacitor through a resistor
40	VCC_REG	-	Power supply. Connect this pin to V _{CC}
41	REGP	O	4.7 V LDO output. (for internal use) Connect capacitor to this pin
42	ISEN	I	Senses buck-boost converter output current. The sense resistor must be placed between DC-DC converter ground and the source of the MOSFET
43	LDRV	I	PWM output
44	AVSSP	-	Connect this pin to GND
45	AVSSS	-	Connect this pin to GND
46	HDRV	O	PWM output
47	REGN	O	VCC-4.7 V LDO output. (for internal use) Connect capacitor to this pin
48	VCC	-	Power supply

LC709511F

PIN FUNCTION (continued)

Pin No.	Pin Name	I/O	Description
49	TEST3	I	Select PWM frequency with this pin. Connect this pin to GND to select 150 kHz. Connect this pin to REGP to select 300 kHz. (Note 1)
50	GATE3	–	Keep this pin open
51	GATE2	O	Control the gate of a FET for Type–A (1)
52	GATE1	O	Control the gate of a FET for Micro–B (sink) or Type–C

1. The Reference software to select 300 kHz is planning.

ABSOLUTE MAXIMUM RATINGS

Parameter	Symbol	Pin/Remarks	Conditions	Min	Typ	Max	Unit
Input Voltage	HV _{IN} max	VBUS1, VBUS2, GATE1, GATE2, GATE3, HDRV, V _{CC} , V _{CC_REG}		–0.3		+14	V
	V _{IN} max	Low voltage pins except for HV pins.		–0.3		+6.5	
Allowable Power Dissipation	Pd max *					1	W
Storage Ambient Temperature	Tstg			–40		125	°C
Operating Junction Temperature	Tjopr			–40		125	

Stresses exceeding those listed in the Maximum Ratings table may damage the device. If any of these limits are exceeded, device functionality should not be assumed, damage may occur and reliability may be affected.

*Thermal resistance evaluation board (size: 120.2 × 59.9 × 1.69 mm, 6 layers) is used. The device is solder-mounted.

RECOMMENDED OPERATING CONDITIONS

Parameter	Symbol	Pin/Conditions	Min	Typ	Max	Unit
Supply Voltage	V _{CC}	V _{CC} , V _{CC_REG}	2.8		13.2	V
Digital Supply Voltage	V _{DD}	DV _{DD}	2.8		5.5	V
Battery Voltage	V _{BAT}	VBAT	3.0		4.35	V
Low Power Mode Ambient Temperature Range	T _{ASTB}	Low power mode and displays battery level	–40		85	°C
Boost Charge Mode Ambient Temperature	T _{ABST}	Boost charge	–20		60	°C
Buck Charge Mode Ambient Temperature	T _{ABUCK}	Buck charge	0		60	°C

Functional operation above the stresses listed in the Recommended Operating Ranges is not implied. Extended exposure to stresses beyond the Recommended Operating Ranges limits may affect device reliability.

LC709511F

ELECTRICAL CHARACTERISTICS (T_A = 25°C)

Parameter	Symbol	Pin/Conditions	Min	Typ	Max	Unit
Consumption Current at Low Power Mode	I _{LOW}	V _{CC} = V _{CC_REG} = 3.7 V I _{LOW} = I _{VCC} + I _{VCC_REG} at Low power mode		15		μA
Consumption Current at Operating Mode	I _{OPR}	V _{CC} = V _{CC_REG} = 5 V I _{OPR} = I _{VCC} + I _{VCC_REG} at Boost charge mode		10		mA
HDRV High-side ON Resistance	HDRVH	HDRV		2		Ω
HDRV Low-side ON Resistance	HDRV L	HDRV		3		Ω
LDRV High-side ON Resistance	LDRVH	LDRV		3		Ω
LDRV Low-side ON Resistance	LDRV L	LDRV		2		Ω
Gate1/2/3 Drive Voltage	V _{GATE}	GATE1, GATE2, GATE3 Pull up these pins to V _{CC} through 510 kΩ	0		0.2	V
VCC UVLO	UVLO	V _{CC} rising		2.72	2.8	V
		UVLO hysteresis		0.1		V
Quiescent Input Current	I _{CHROFF}	VBUS1, VBUS2, Charge mode Switching OFF current VBUS = 5 V			3	mA
Thermal Shut Down Threshold	THD			105		°C
Frequency	F _{BC}	TEST3 = Low		150		kHz
		TEST3 = High (Note 2)		300		kHz

Product parametric performance is indicated in the Electrical Characteristics for the listed test conditions, unless otherwise noted. Product performance may not be indicated by the Electrical Characteristics if operated under different conditions.

2. The Reference software to select 300 kHz is planning.

ELECTRICAL CHARACTERISTICS (T_A = -40 to +85°C, V_{DD} = 2.8 V to 5.5 V, T_A = 25°C for typical values.)

Parameter	Symbol	Pin/Conditions	Min	Typ	Max	Unit
LED Sink Current	I _{LED}	LED1, LED2, LED3, LED4		10		mA
VBUS Input Detection Voltage	V _{BDET}	VBUS1, VBUS2 rising			4	V
High Level Input Voltage	V _{IH(1)}	PBT	0.3 * V _{DD} + 0.7		V _{DD}	V
Low Level Input Voltage	V _{IL(1)}	PBT	V _{SS}		0.15 V _{DD} + 0.4	V
High Level Output Voltage	V _{OH}	TSW, BSTEN IOH = -0.4 mA	V _{DD} - 0.4			V
Low Level Output Voltage	V _{OL(1)}	BSTEN IOL = 0.4 mA			0.4	V
Pull-up Resistance at Turn On	R _{PU}	FGADJ		50		kΩ

Product parametric performance is indicated in the Electrical Characteristics for the listed test conditions, unless otherwise noted. Product performance may not be indicated by the Electrical Characteristics if operated under different conditions.

LC709511F

ELECTRICAL CHARACTERISTICS ($T_A = -40$ to $+85^\circ\text{C}$, $V_{DD} = 3.0$ V to 5.5 V, $T_A = 25^\circ\text{C}$ for typical values.)

Parameter	Symbol	Pin/Conditions	Min	Typ	Max	Unit
-----------	--------	----------------	-----	-----	-----	------

BC1.2/HVDCP

D- Pull Down Resistance	RDM_DWN	USB1-, USB2-		19.53		k Ω
D+ Pull Down Resistance	RDP_DWN	USB1+, USB2+		19.53		k Ω
D- Source Voltage	VDM_SRC	USB1-, USB2-		0.6		V
D+ Source Voltage	VDP_SRC	USB1+, USB2+		0.6		V
D- Sink Current	IDM_Sink	USB1-, USB2-		100		μA
D+ Sink Current	IDP_Sink	USB1+, USB2+		100		μA
Data Line Leakage Resistance	R _{DAT_LKG}	USB1-, USB1+, USB2-, USB2+	300	900	1500	k Ω
HVDCP Resistance Across D+/-	R _{HVDCP_DAT}	USB1-, USB1+, USB2-, USB2+			45	Ω
DCP Resistance Across D+/-	R _{DCP_DAT}	USB3-, USB3+			200	Ω
2.7 V Output Voltage	VD_27	USB3-, USB3+, $V_{DD} = 4.0$ V to 5.5 V	2.55	2.7	2.85	V
2.0 V Output Voltage	VD_20		1.9	2.0	2.1	V
2.7 V/2.0 V Output Resistance	RD_30		24	32	40	k Ω

TYPE-C COMMUNICATION CHANNEL

Current Source (Detached Source)	Rp_80	CC1A, CC2A, CC1B, CC2B	64	80	96	μA
Current Source (1.5 A)	Rp_180	CC1A, CC2A, CC1B, CC2B, $V_{DD} = 4.0$ V to 5.5 V	166	180	194	μA
Current Source (3 A)	Rp_330		304	330	356	μA
Rd Pull-Down Resistance	Rd	CC1A, CC2A	4.59	5.1	5.61	k Ω
Pull-Down Voltage in Dead Battery	V _{DDB}				2.18	V
Threshold when Source is attached or detached	VT _{SRC}		0.15	0.2	0.25	V
Threshold when Sink is attached or detached	VT _{SNK}	CC1A, CC2A, CC1B, CC2B	1.50	1.60	1.70	V

Product parametric performance is indicated in the Electrical Characteristics for the listed test conditions, unless otherwise noted. Product performance may not be indicated by the Electrical Characteristics if operated under different conditions.

LC709511F

BLOCK DIAGRAM

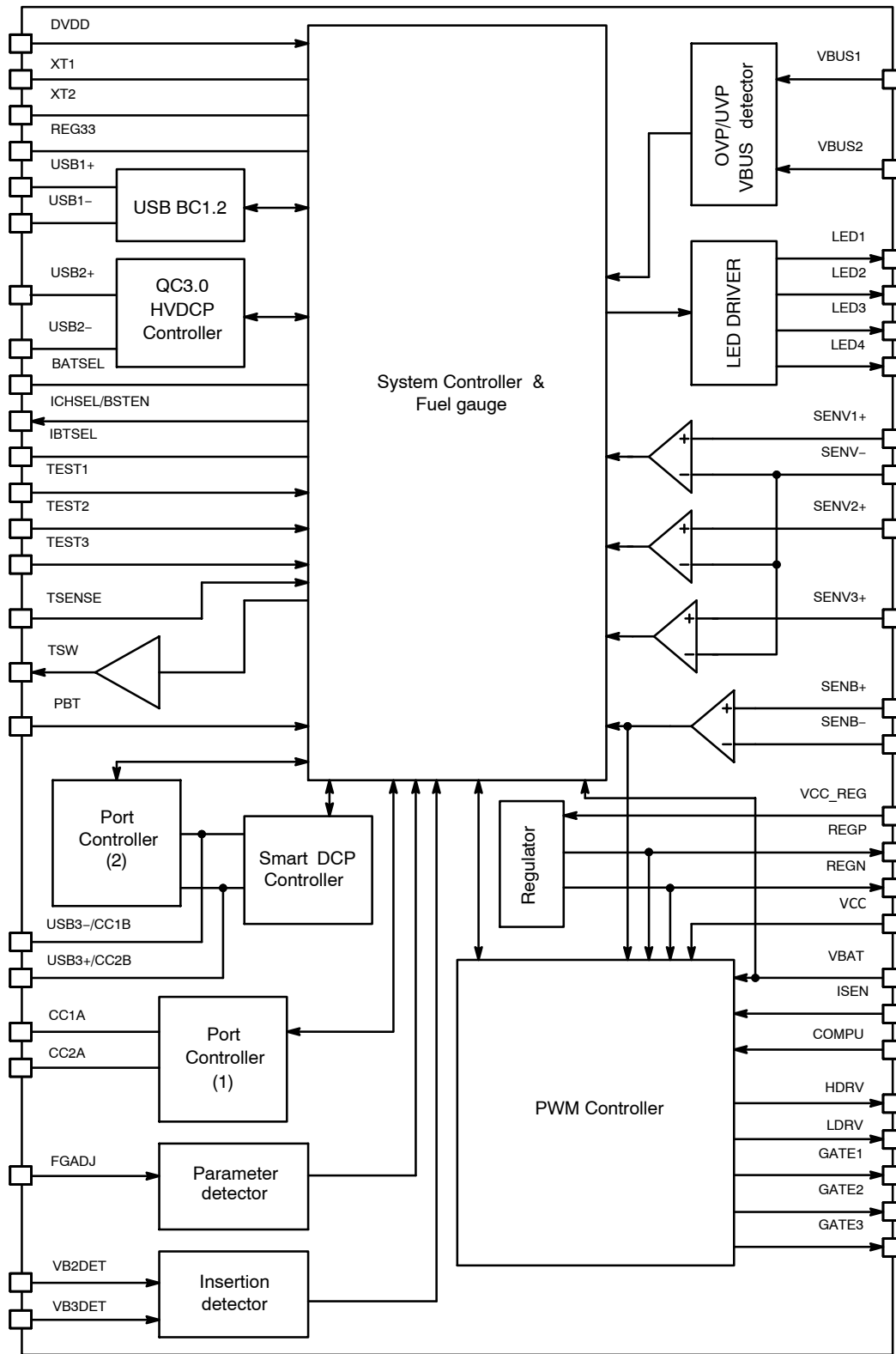

Figure 2. Block Diagram

REFERENCE SOFTWARE

Writing Tool

This device has non-volatile memory, and can implement the function of each USB port by writing software. It is capable of writing on user application board with dedicated writing tool. Figure 3 shows a connection between the application board and the writing tool. Please refer to an application note for the details of the tool.

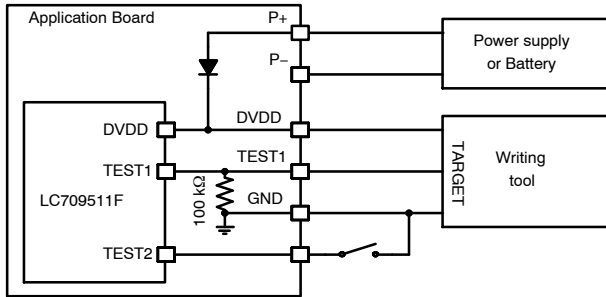

Figure 3. Connection Example to Write Software

USB Support

Appropriate software enables various functions of USB ports. ON Semiconductor provides some software as reference. It is active to download them from the homepage of ON Semiconductor.

The explanation about the functions of two Reference software are as follows. They are distinguished by the type name which is FW02 and FW05.

- FW02:
Micro-B Sink, Type-A Source × 2-ch, Quick Charge 3.0 HVDCP, USB detection, Smart switch, Boost auto start-up, External Boost-IC.

- FW05:
Type-C Sink/Source, Type-A Source, Quick Charge 3.0 HVDCP, USB detection, Smart switch, Boost auto start-up, External Boost-IC.

The Relationship between the Reference software and the USB port functions is shown in Table 1 and Figures 4, 5 and 6. USB1 port of FW02 is a power sink for Buck charge. And it contains USB Detection functions of BC1.2 and divided mode. USB2 port is a power source for Boost charge. Quick Charge 3.0 are only enabled for USB2 port. Another power source that is USB3 supports DCP and Divided mode. The USB3+/- pins are Smart switch, they will switch to DCP or Divided mode so that connected device can receive maximum power. USB3 port is boosted by an external Boost-IC. This device runs the Boost-IC when it detects the plug insertion to USB3 port.

USB1 port of FW05 is capable of controlling USB Type-C and Quick Charge 3.0 and BC1.2. It can be dual-role, source or sink. The CC1x and CC2x pins will detect the connection and the role. When the role is a sink, the USB1+/- pins will detect source capacity according to BC1.2, Divided mode or Type-C current. When the role is a source, it behaves as Quick Charge 3.0 HVDCP. In the Type-C port Buck charge with Dead battery and Electronically marked cable are supported.

Power Bank Application

Figure 7 and 8 show typical Power Bank application with FW02 and FW05 each.

- Buck charge mode: Built-in battery charging via USB.
- Boost charge mode: Charging the device from built-in battery via USB.

Table 1. REFERENCE SOFTWARE VS USB FUNCTIONS

Reference software	USB Port	USB Type	D+/- Pins	Buck Charge	Boost Charge	Quick Charge 3.0 HVDCP	USB Detection	Smart Switch	Boost Auto Start-up	External Boost-IC
FW02	USB1	Micro-B	USB1+ USB1-	✓	-	-	✓	-	-	-
	USB2	Type-A	USB2+ USB2-	-	✓	✓	-	-	✓	-
	USB3	Type-A	USB3+ USB3-	-	✓	-	-	✓	✓	✓
FW05	USB1	Type-C	USB1+ USB1-	✓	✓	✓ (Source Mode)	✓ (Sink Mode)	-	✓ (Note 3)	-
	USB3	Type-A	USB3+ USB3-	-	✓	-	-	✓	✓	✓

3. Communication channel detects the Sink connection.

LC709511F

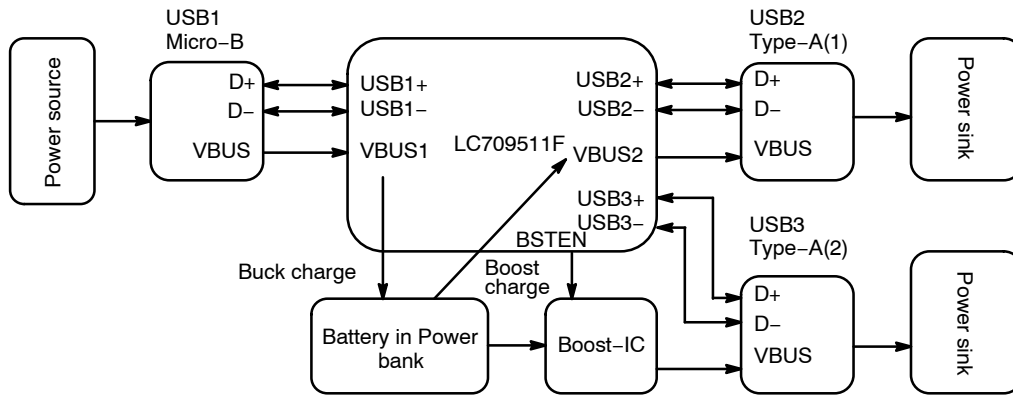

Figure 4. The Function of FW02

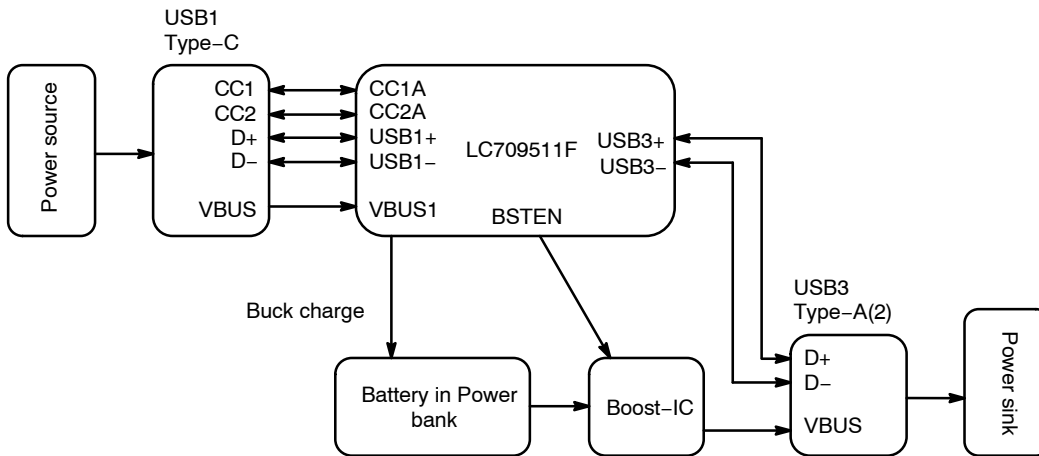

Figure 5. The Function of FW05 (USB1 Port is Sink)

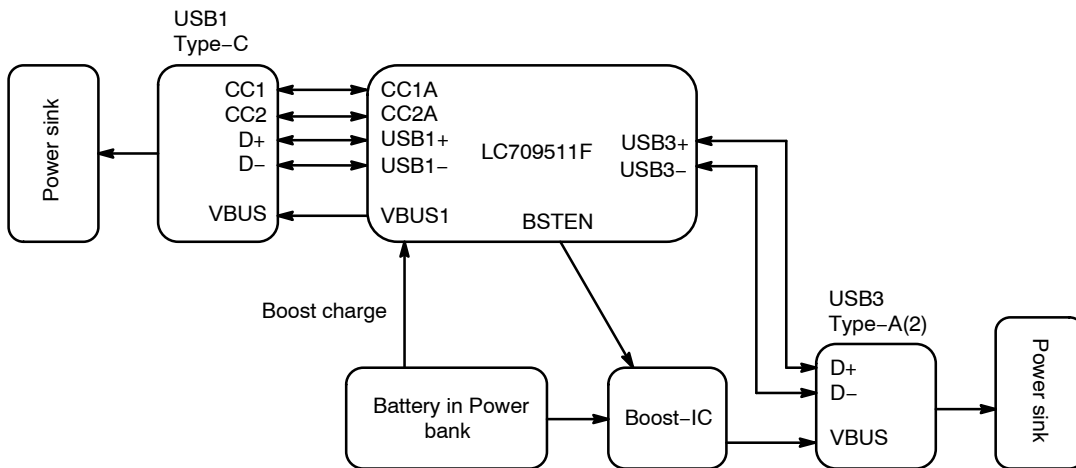

Figure 6. The Function of FW05 (USB1 Port is Source)

LC709511F

Micro-B (Sink: BC1.2) + Type-A (1) (Source: Quick Charge 3.0 HVDCP) + Type-A (2) (Source: DCP and Divided Mode)

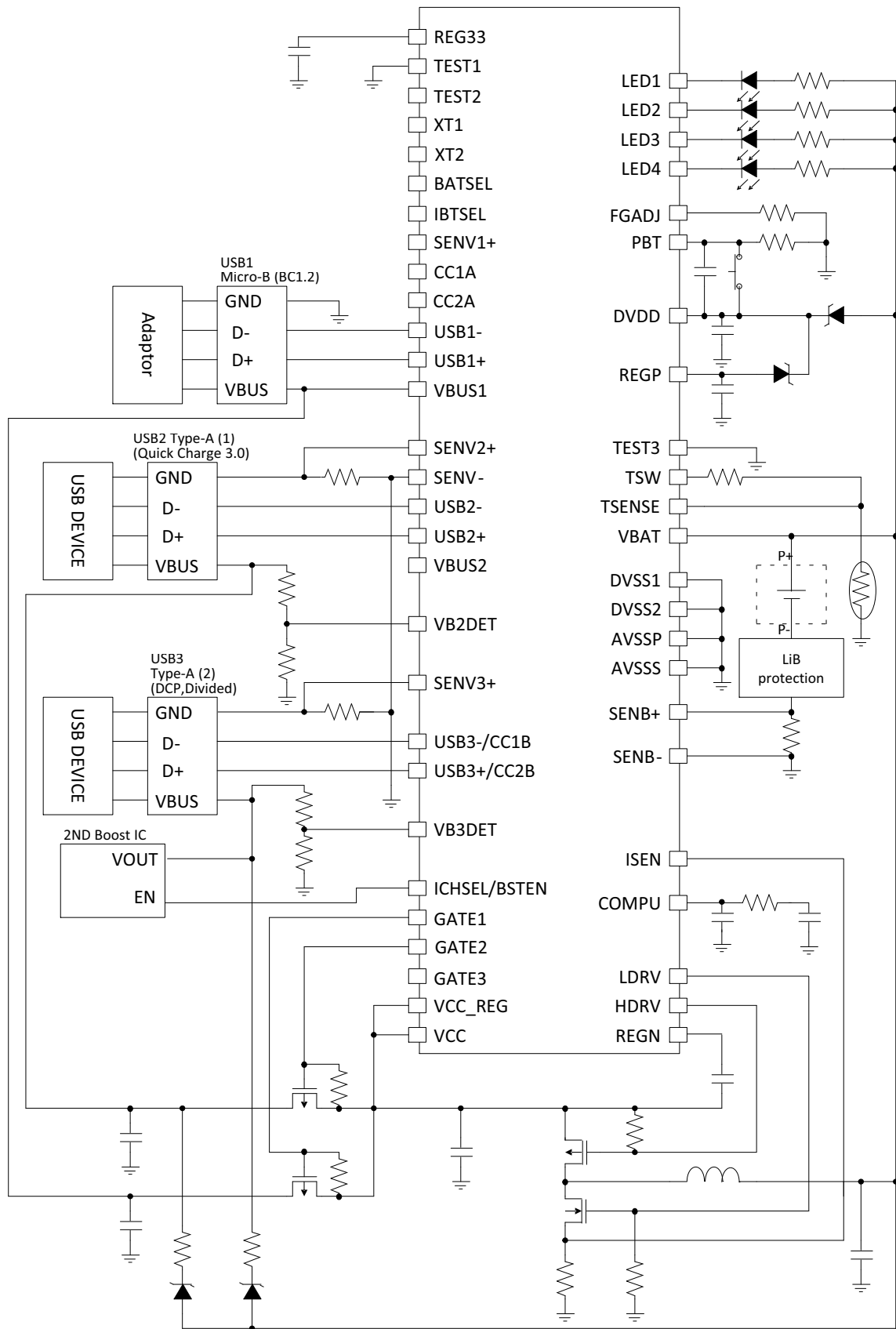

Figure 7. Power Bank Application (Reference Software: FW02)

LC709511F

Type-C (Sink:BC1.2, Source:Quick Charge 3.0 HVDCP) + Type-A (Source: DCP and Divided mode)

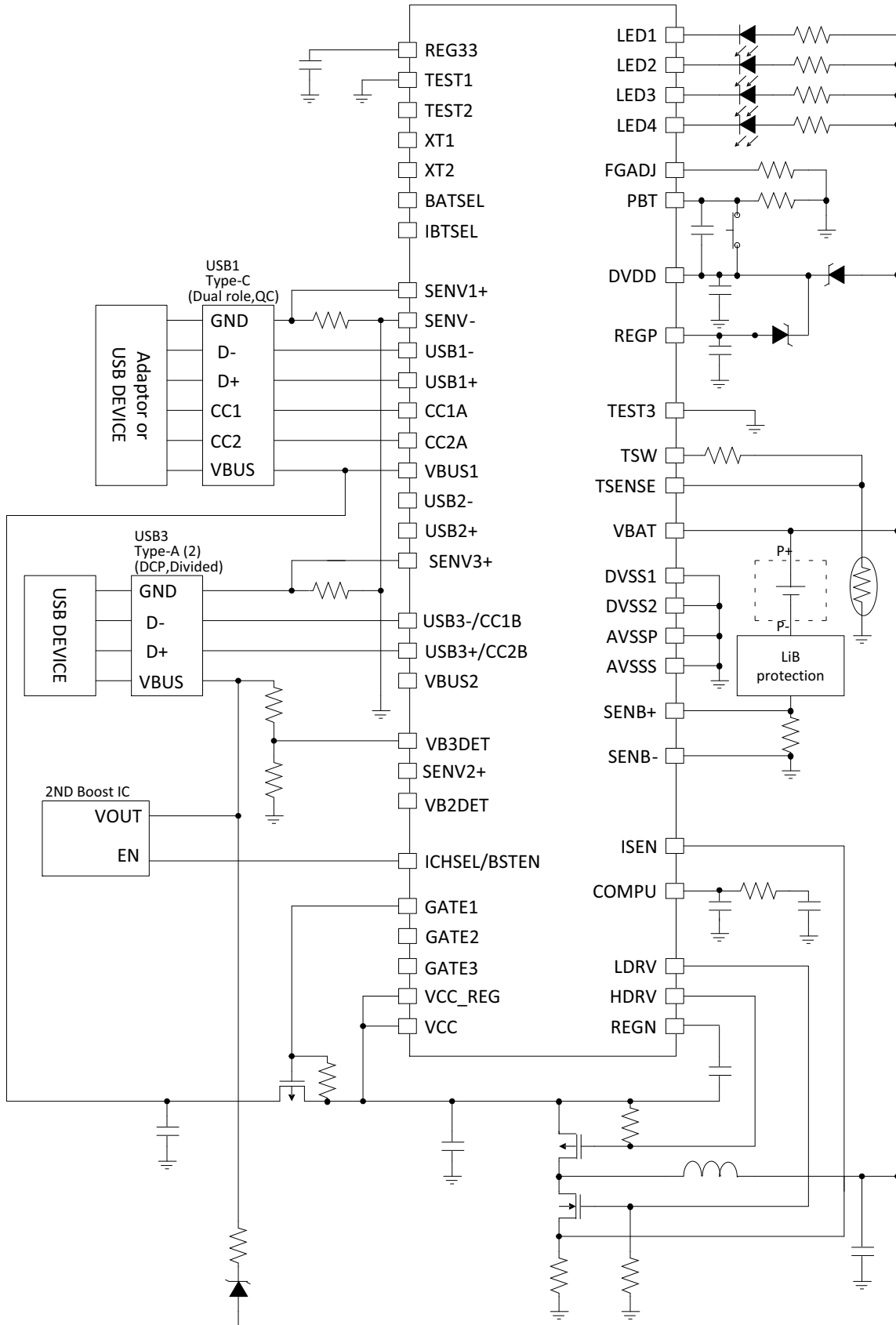

Figure 8. Power Bank Application (Reference Software: FW05)

MODE TRANSITION

This device is set to a Low power mode to minimize power consumption when no USB device is connected. If the connection is detected, it transitions into Operating mode.

FW02

In Figure 9: FW02 state diagram, when the VBUS1 rise (input) is detected and VBUS1 voltage exceeds the V_{BDET} , it transitions from Low power mode to Operating mode. Buck charge is started when VBUS1 voltage exceeds the V_{BUVP} . If the input plug is removed, it will transition into the Low power mode again.

During the Low power mode, if the output plug insertion is detected or the push button is pressed long, it transitions into the Operating mode to start 5 V Boost charge. If the detected port is USB2, at first 5 V is applied to V_{CC} , then it opens GATE2. USB2 port will start as Quick Charge 3.0 HVDCP. 9 V or 12 V or Continuous mode request is received from the portable device, the Boost voltage will automatically change according to the request.

If USB3 with External Boost-IC is connected, BSTEN is set to “HIGH” to output 5 V.

Boost charge will stop under following conditions of: a) Plug for the output is removed, b) Output current to the connected portable device falls under I_{BTERM} , c) Built-in battery voltage is judged as low, or d) Input plug is connected. If all Boost charge stops and input plug doesn't be connected, this device will transition into the Low power mode. If both the output-plugs and the input plug are connected, it will transition into Buck charge. Refer to Table 2.

FW05

In Figure 10: FW05 state diagram. Low power mode will transition into the Operating mode under following conditions of: a) CC1 or CC2 ports detect a device is attached, or b) VBUS1 voltage exceeds the V_{BUVP} , or c) Connection to USB3 port is detected by VB3DET, or d) Push button is pressed for long.

If this device detects VBUS1 rising or Attached.SNK of USB1 port, it will start Buck Charge. If it detects Attached.SRC of USB1 port or connection to USB3 port, it will start Boost charge. Boost charge can be performed for USB1 and USB3 ports at the same time. If all Boost charge stops and CC ports are Unattached, it will transition into the Low power mode again.

Figure 11 shows detailed Type-C port state diagram. When CC ports are in Unattached state, it alternates between Unattached.SRC and Unattached.SNK. It outputs R_p in the Unattached.SRC, and outputs R_d in the Unattached.SNK. The R_p current in Unattached.SRC and AttachWait.SRC is fixed to the value for default USB. In Unattached.SNK If R_p is detected on CC1 or CC2, it transits into AttachWait.SNK. In addition when VBUS1 voltage exceeds V_{BUVP} , it will transit into Attached.SNK and start Buck charge.

In Unattached.SRC if R_d or R_a is detected on CC1 or CC2 port, it transits into AttachWait.SRC. In AttachWait.SRC if VBUS1 voltage is lower than V_{SAFE0V} , it checks CC1 and CC2 status and transits according to Table 3. When R_a is connected to CC1 or CC2, the other open port keeps toggling. When it becomes to Attached.SRC, it will start Boost charge. In Attached.SRC R_p current becomes to the set value by Software configuration. Refer to Table 11.

Table 2. CONNECTED DEVICE VS CHARGE MODES

FW02

Connected Device			Charge Mode
USB1 Micro-B	USB2 Type-A	USB3 Type-A	
Source	-	-	Buck Charge
Source	Sink	-	
Source	-	Sink	
Source	Sink	Sink	
-	Sink	-	Boost USB2
-	-	Sink	Boost USB3
-	Sink	Sink	Boost USB2 & USB3

FW05

Connected Device		Charge Mode
USB1 Type-C	USB3 Type-A	
Source	-	Buck Charge
Source	Sink	
Sink	-	Boost USB1
-	Sink	Boost USB2
Sink	Sink	Boost USB1 & USB3

Table 3. CC STATUS TO JUDGE SINK

CC1	CC2	State
Open	Open	Nothing Attached
Rd	Open	Enter Attached.SRC
Open	Rd	
Open	Ra	Attached CC: Keep AttachWait.SRC Unattached CC: Keep toggling
Ra	Open	
Rd	Ra	Enter Attached.SRC
Ra	Rd	
Rd	Rd	Keep AttachWait.SRC
Ra	Ra	

LC709511F

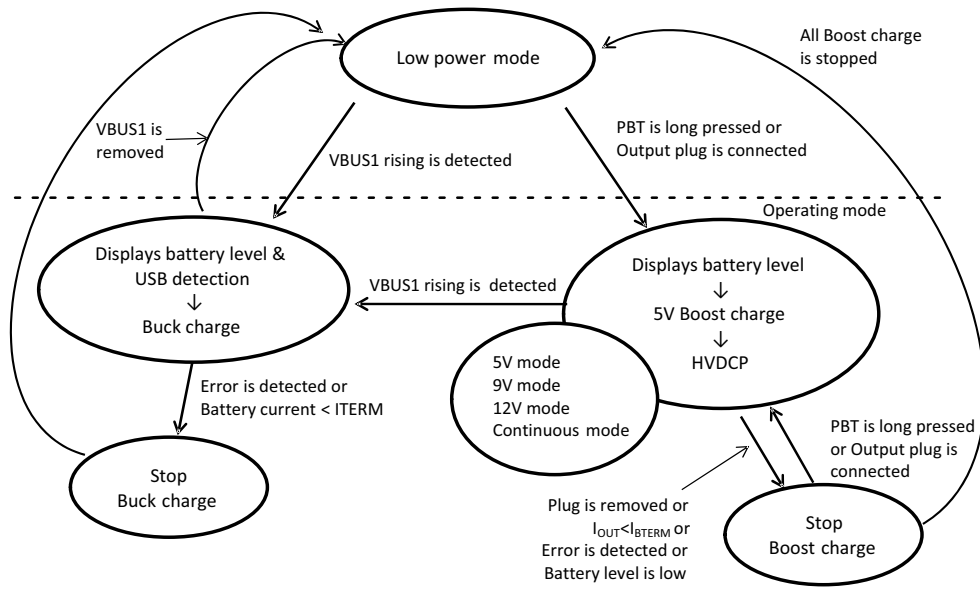

Figure 9. FW02 State Diagram

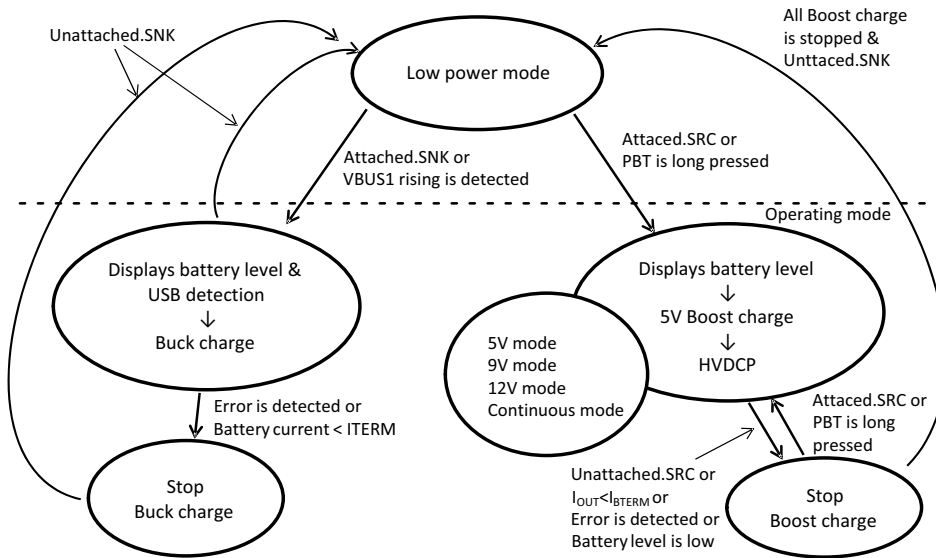

Figure 10. FW05 State Diagram

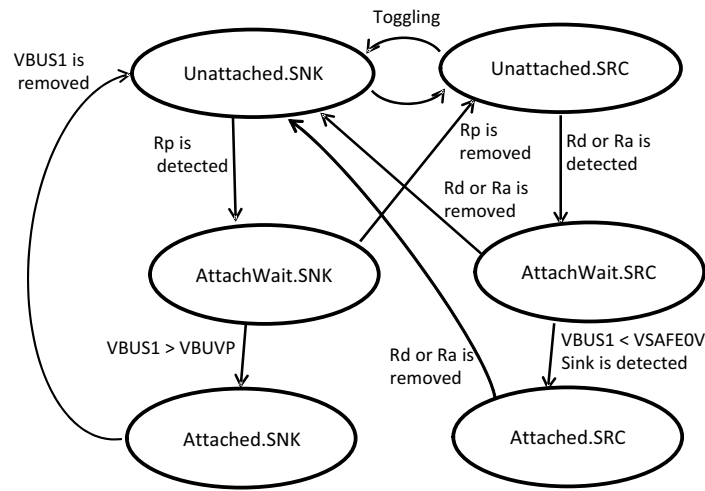

Figure 11. Type-C Port State Diagram

BUCK CHARGE

The buck charge is configured by three states: pre-charge, constant current charge, and constant voltage charge. Figure 12 shows the flow of battery charge.

Pre-charge Mode

Pre-charge is executed when battery voltage is below 3.25 V at the start of buck charge. In this case charging current is limited by I_{PRE} . If battery voltage exceeds 3.25 V, it transitions into the constant current charge mode.

Constant Current Charge Mode

Charging with constant current. Charging current is limited by I_{CHG} and input current from USB port. (Refer to “Input over Current Protection”) When battery voltage reaches V_{CHG} , it transitions into the Constant voltage charge mode.

Constant Voltage Charge Mode

Charging with constant voltage. Charging current will decrease as it gets closer to the full charge. When charging current decreases to the termination current, the charge

operation will complete. The termination current is set by I_{TERM} .

Safety Timer

If the continuous battery charging time exceeds T_{CMAX} , it will force-quit the charging operation. It will start charging again by detecting Re-connect at the supply source.

Buck Charge Condition vs Temperature

This device changes charge voltage and charge current according to the battery temperature measured by the external thermistor. Refer to Figure 13. If the temperature exceeds T_{WARM} , Termination Battery Voltage decreases in 0.2 V. If the temperature exceeds T_{HOT} , it will stop charging. If the temperature drops below T_{COOL} , charge current will become a half of the constant charge current I_{CHG} value. If the temperature drops below T_{COLD} , charge stops. Buck charge does not re-start until the supply source is unplugged/plugged if even once the temperature is over T_{HOT} or below T_{COLD} .

LC709511F

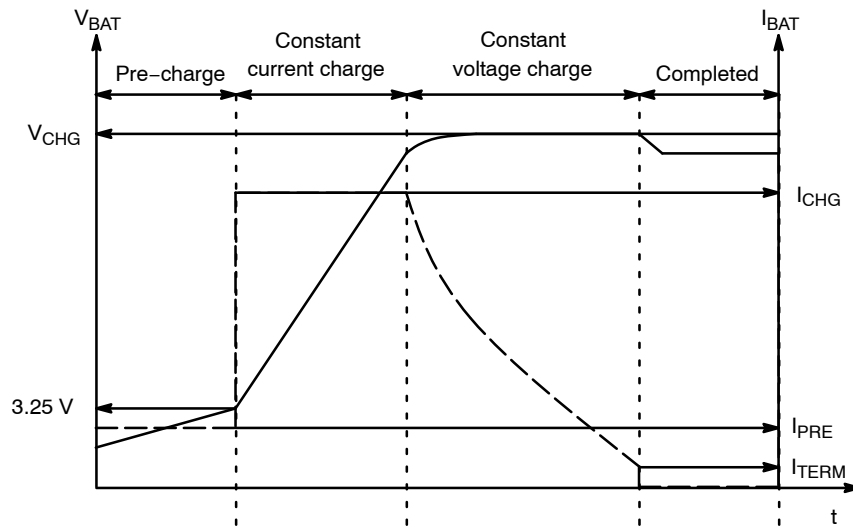

Figure 12. Buck Charge States

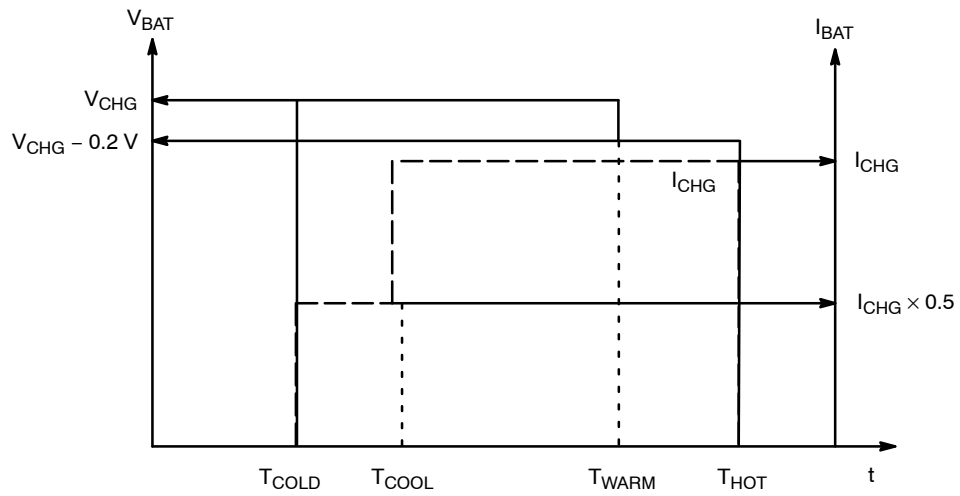

Figure 13. Charge Voltage & Current & Battery Temperature

BOOST CHARGE

Boost Auto Start-up

This device can detect USB Type-A plug insertion using VB2DET/VB3DET pins. Battery voltage through diode on the application board is supplied to VBUS. This device constantly monitors the VBUS voltage using VB2DET/VB3DET pins and judges a plug insertion from the voltage shift. In the case of USB Type-C, CC1 and CC2 pins will detect the plug insertion.

If a plug insertion is detected and Buck charge dose not run, Boost charge will start automatically.

Boost Manual Start-up

When the external push button is depressed for more than T_{LBOT} , the device will wake up and begin Boost charge to Type-A port.

End of Boost Charge

During Boost charge, if the output current falls below I_{BTERM} , it will stop. If all boost charge stops, this device

transitions into the Low power mode. It is necessary that the stopped VBUS are unplugged or Push button is long pressed for re-start of boost charge.

Boost Charge Prohibition for Empty Battery

When the battery level is 0% or the no-load battery voltage is under 3.3 V, boost charge will not start. If the battery level becomes 0% or the battery voltage drops under 3 V while executing the boost charge, boost charge will stop and transition into the Low power mode.

Boost Charge vs Temperature

This device stops Boost charge according to the battery temperature measured by the external thermistor. If the temperature exceeds T_{HOT2} or drops below T_{COLD2} , it will stop Boost charge to all VBUS and transition into the Low power mode.

PROTECTION

Thermal Shut Down

This device has a built-in thermometer. If device's internal temperature exceeds the THD, it will stop all Buck charge and Boost charge. It cannot restart charging if device's internal temperature is above THD.

Over/Under Voltage Protection

VCC pin can detect under voltage, VBUS1, VB2DET and, VB3DET can detect over-voltage as well as under-voltage. It will stop charging to the port that the over-voltage or under-voltage is detected.

Input Over Current Protection

The set input current threshold limits the charge current in Buck charge mode. This device controls the charge current so that it doesn't exceed the threshold.

The threshold will be decided based on these value.

- I_{CHG} : Constant Charge Current
- USB Detection Max current (Refer to Table 5)
- Type-C current (for Type-C port)

Boost Output Over Current Protection

During boost charge, if the output current exceeds I_{OUTOCB} it will stop boost charge.

INTERFACE

Push Button

The PBT pin should be connected to an external push button and be pulled-down by an external resistor. When the PBT pin is driven to a logic level high ("H") by pressing the push button, the device recognizes that the push button was pressed. Furthermore if the "H" level time exceeds the T_{LBOT} value, it is recognized as long-press, and if it is below the T_{LBOT} value, it is recognized as short-press. Refer to Table 4 about the logic level high timing.

Table 4. PUSH BUTTON TIMING

Function	Symbol	Min	Max	Unit
Time Recognized as Short-press	T_{SBOT}	0.06	1.8	s
Time Recognized as Long-press	T_{LBOT}	2.2		s

NOTE: These parameters are implemented by Reference software.

USB Detection Function

USB1 has USB Detection function. This function limits input current in Buck charge mode. The supported modes are shown in Table 5. If the connected device is DCP or HVDCP, the limit is defined by only I_{CHG} or Type-C current.

Table 5. USB1 DETECTABLE MODE

Mode	Maximum Charge Current
SDP	0.5 A
CDP	1.5 A
DCP	–
HVDCP	–
Divided Mode 1	1 A
Divided Mode 2	2.1 A
Divided Mode 3	2.4 A

Quick Charge 3.0 HVDCP

This device supports Quick Charge 3.0 HVDCP Class A. USB2 ports receives the request of Quick Charge 3.0 from Portable device. USB2+ and USB2- is shorted with RDCP_DAT. If the negotiation between Portable device and this device is successful, this device opens USB2+ and USB2-, and USB2- is pulled down with RDM_DWN. It monitors USB2+/- voltage and change the output voltage according to D+ and D- status that is the Potable device request. (Table 6) The HVDCP operating range is shown in Figure 14.

Table 6. D+/- VS OUTPUT VOLTAGE

Portable Device		Output Voltage
D+	D-	
0.6 V	0.6 V	12 V
3.3 V	0.6 V	9 V
0.6 V	3.3 V	Continuous Mode
3.3 V	3.3 V	Previous Voltage
0.6 V	GND	5 V

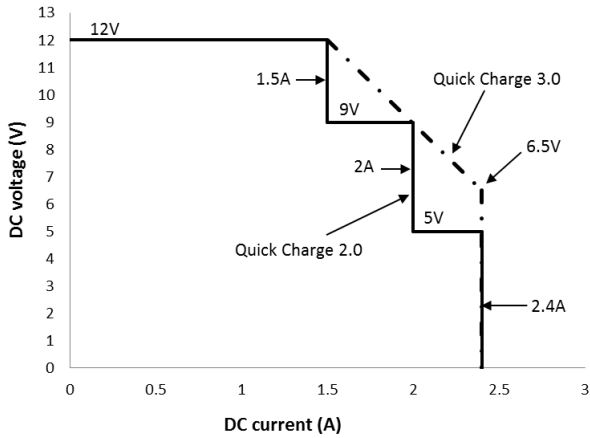

Figure 14. Quick Charge 2.0/3.0 HVDCP Operating Range

USB Smart Switch

There are two modes for USB3 data lines. One is Divided mode. Figure 15 shows it. In this mode, 2.7 V is applied on each data line. The other mode is DCP mode. Figure 16 shows it. In this mode, USB data lines are shorted. The Divided mode is the first mode after USB3 connection. If a device that requires DCP is connected to USB3, this device will change the data lines to DCP mode automatically. DCP mode is maintained until disconnection is detected.

The voltage which is applied in each data line in Divided mode can be selected from either 2.0 V or 2.7 V by Software configuration. Refer to Table 13.

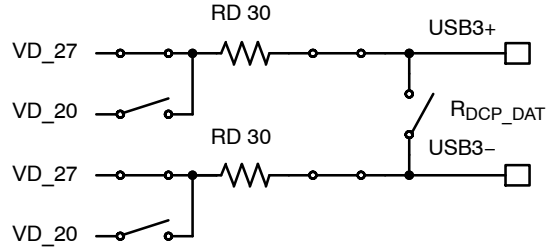

Figure 15. Divided Mode (D+ = D- = 2.7 V)

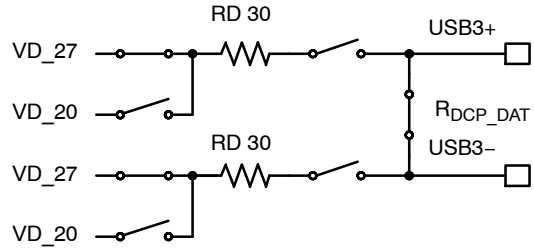

Figure 16. CP Mode

LC709511F

LED

Battery Level

A short-press of the push button will turn on LED drive port to indicate the battery level for T_{LBAT} period. At this time, LEDs light up in the order from LED1 with T_{LDELAY} delay after each light up. Refer to Figure 17 about the timing chart.

Table 7 shows the relationship between battery levels and LEDs. When this device judge to be from 1% to 10% in the battery level, LED1 is flashing. Refer to Figure 18 about the flashing timing.

Status Indicator

Table 8 shows the status which turn on LED drive port. Table 9 and Figures 19–24 show LED display timing in each status.

Table 7. BATTERY LEVEL VS LEDS

LED	Battery Level
LED1–4 On	76%–100%
LED1–3 On	51%–75%
LED1–2 On	26%–50%
LED1 On	11%–25%
LED1 Flashing	1%–10%
LED Off	0%

NOTE: These battery levels are typical values implemented by Reference software.

Table 8. STATUS VS LED PATTERN

Status	LED Timing	Condition
Buck Charge	(See Figure 19)	VBUS1 plug insertion is detected, and Buck charge is started
Boost Charge	(See Figure 20)	Output plug insertion is detected or push button is depressed, and Boost charge is started
Over Temperature in Buck Charge	(See Figure 21)	In Buck charge temperature which is measured by thermistor exceeds T_{HOT} or T_{COLD}
Over Temperature in Boost Charge	(See Figure 22)	In Boost charge temperature which is measured by thermistor exceeds T_{HOT2} or T_{COLD2}
Thermal Shutdown	(See Figure 23)	Thermal shutdown occurs
Thermistor Disconnection	(See Figure 24)	The disconnection of thermistor is detected

Table 9. LED TIMING

Timing	Symbol	Typ	Unit
Battery Level Indication Time	T_{LBAT}	3	s
Battery Level Indication Delay	T_{LDELAY}	0.1	s
Lighting Time of Flashing to Indicate Battery Level	T_{FLS_L}	0.25	s
Lights Out Time of Flashing to Indicate Battery Level	T_{FLS_H}	0.25	s
Buck Charge Lights on Delay after Transition into Operating Mode	T_{SBUCK}	0.2	s
Lighting Time of Flashing in Buck Charge	T_{BKF_L}	0.25	s
Lights Out Time of Flashing in Buck Charge	T_{BKF_H}	0.75	s
Lights Up Time at Start of Boost Charge	T_{LSTA}	2	s
Lighting Time of Flashing in Boost Charge	T_{BTF_L}	0.2	s
Lights Out Time of Flashing in Boost Charge	T_{BTF_H}	2.8	S
VBUS1 Judge Delay after Transition into Operating Mode	T_{VBDET}	0.2	s
Temperature of TSENSE Detection Time	T_{TSDDET}	2	s
TSENSE Disconnect Detection Time	$T_{TDISDET}$	2	s
Temperature of Internal Thermistor Detection Time	T_{ITDET}	2	s
Lighting Time during VBUS1 Warning	T_{FLS2_L}	0.1	s
Lights Out Time during VBUS1 Warning	T_{FLS2_H}	1.9	s
Lights Out Time during Temperature Warning	T_{FLS3_H}	0.3	s
Lights Interval Time during Temperature Warning	T_{FLS_INT}	3	s

NOTE: These parameters are typical times implemented by Reference software.

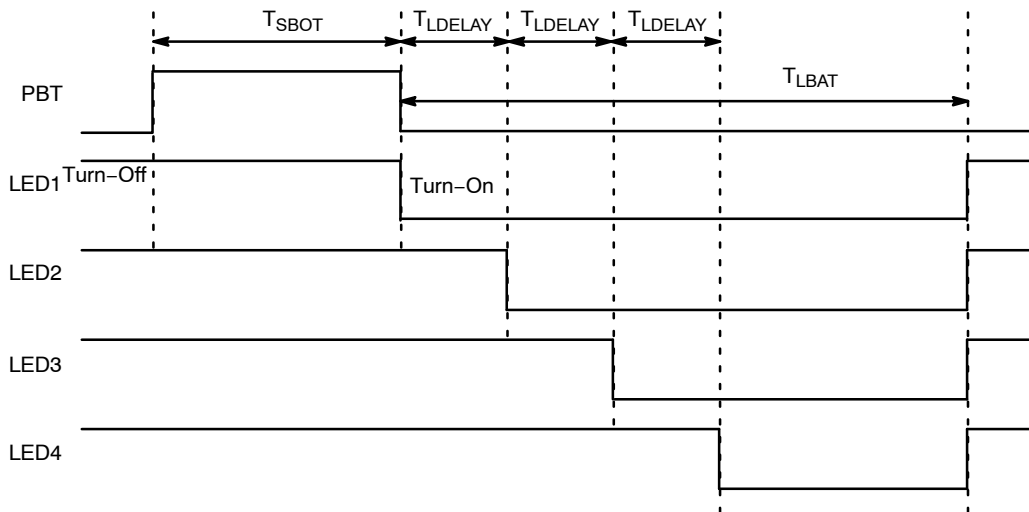

Figure 17. LED Display Timing Chart of Battery Level by a Short-press (Battery level: 76–100%)

LC709511F

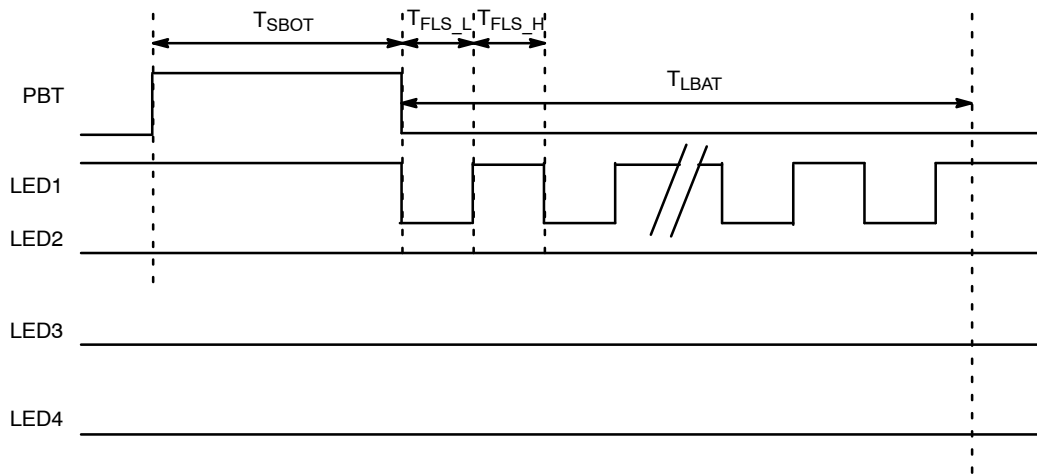

Figure 18. LED Display Timing Chart of Battery Level by a Short-press (Battery Level: 1–10%)

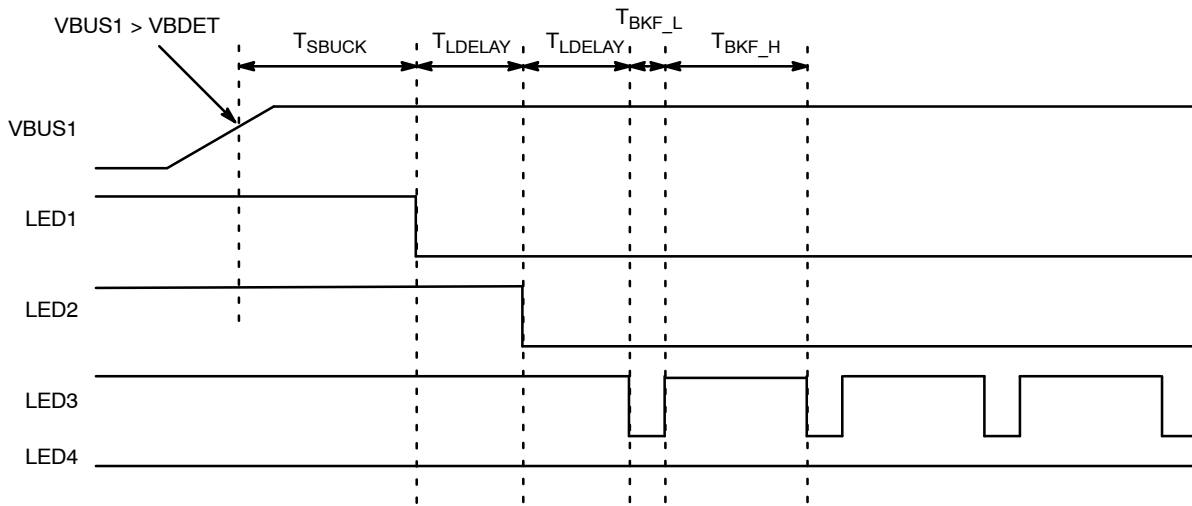

Figure 19. LED Display Timing Chart at Buck Charge Start (Battery Level: 51–75%)

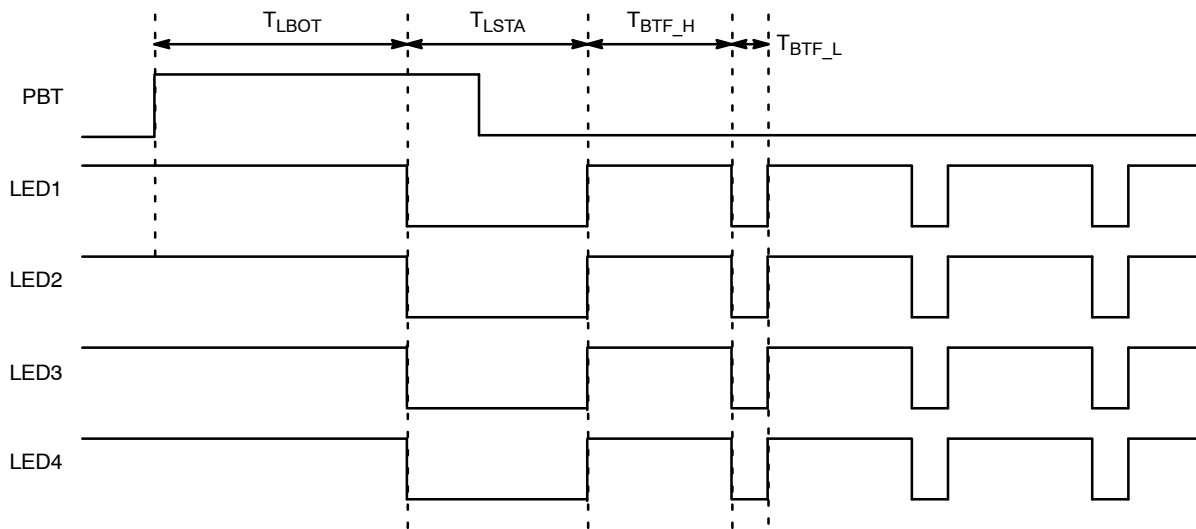

Figure 20. LED Display Timing Chart at Boost Charge Start by a Long-press

LC709511F

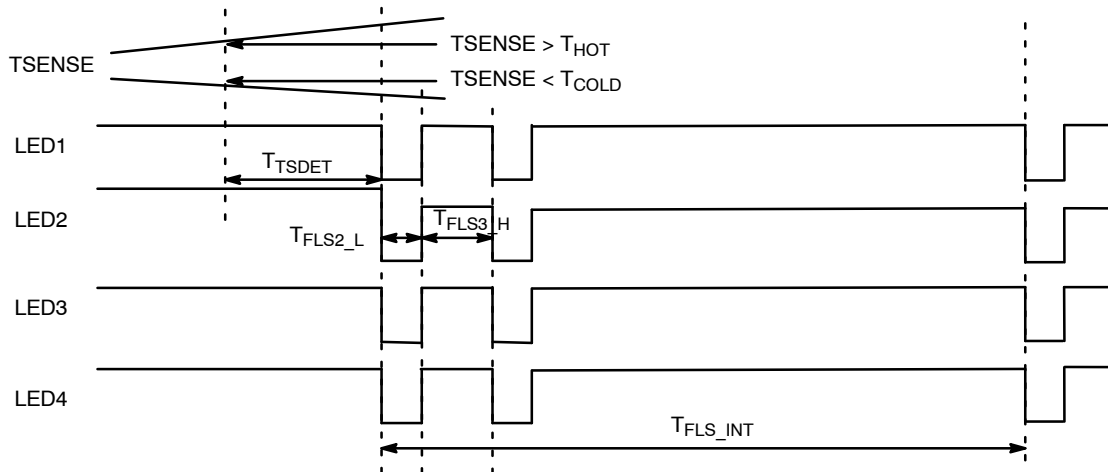

Figure 21. LED Display Timing Chart when Over Temperature is Detected in Buck Charge

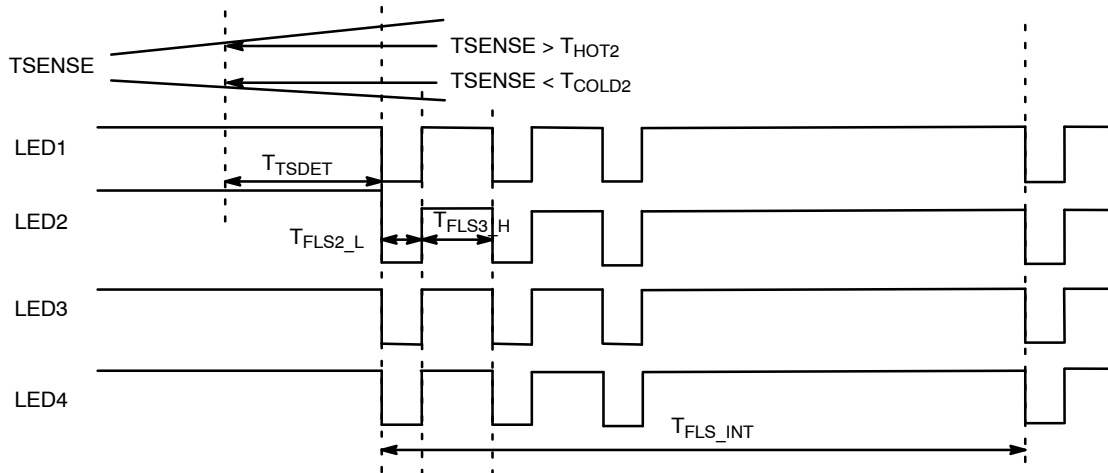

Figure 22. LED Display Timing Chart when Over Temperature is Detected in Boost Charge

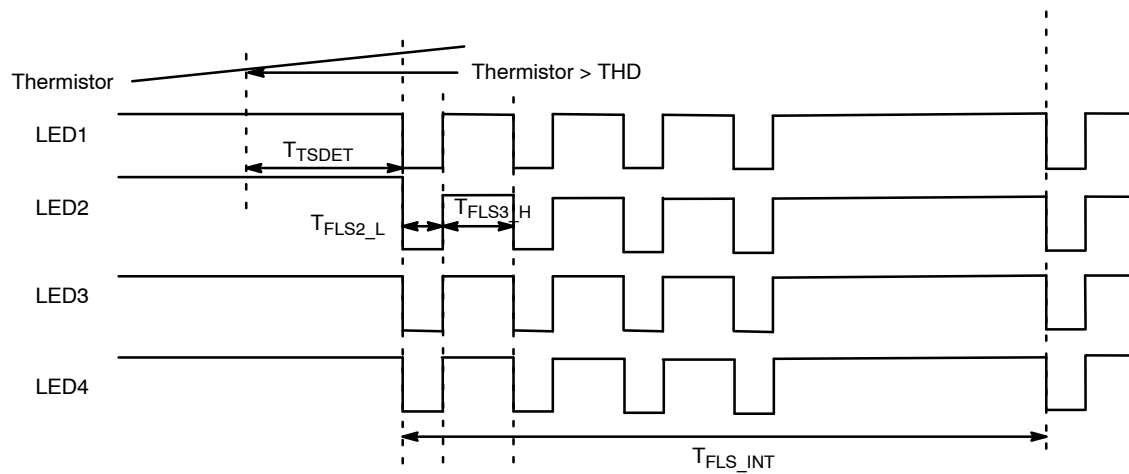

Figure 23. LED Display Timing Chart when Thermal Shutdown Occurs

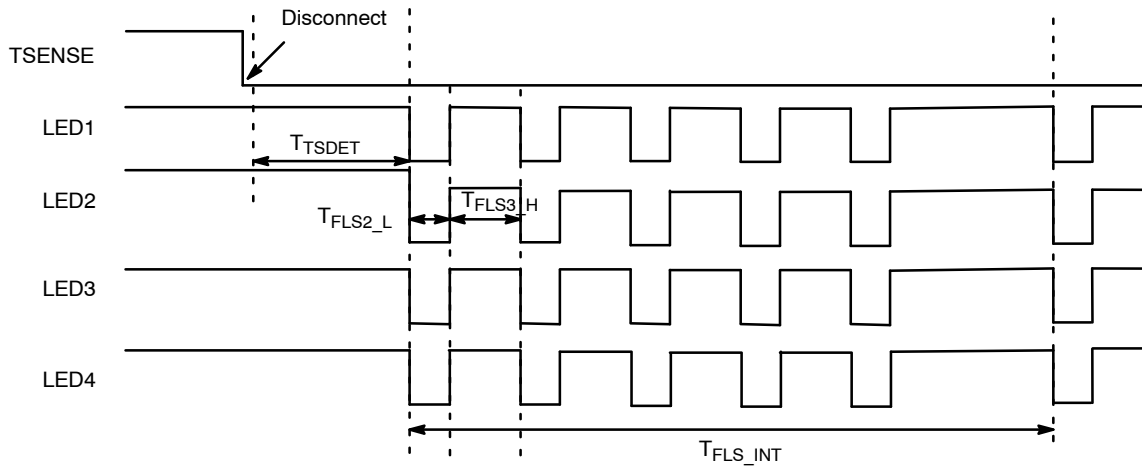

Figure 24. LED Display Timing Chart when the Disconnection of Thermistor is Detected

BOOST EFFICIENCY

Appropriate components of the converter for the maximum boost and buck charge power can be selected. Table 10 shows an example of components for High power. Figures 25, 26 and 27 show the Boost Efficiency of the evaluation board using these components. Refer to an application note for the detail of the evaluation board and the result of the other components.

Table 10. COMPONENTS EXAMPLE AROUND CONVERTER

Inductor	L	PWM Freq.	Switching FET
Panasonic	4.6 μ H	150 kHz	ECH8310 x 2 NTTFS4H05N x 2

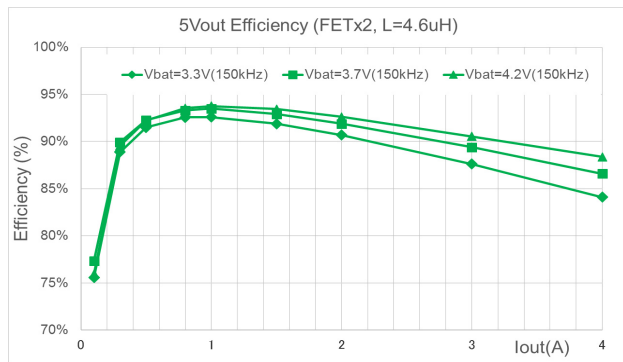

Figure 25. Boost Efficiency (VOUT = 5 V)

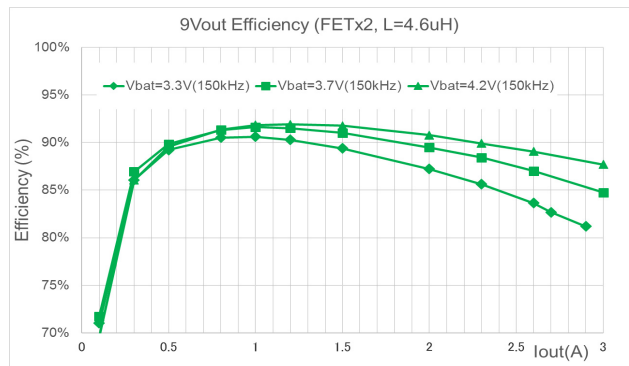

Figure 26. Boost Efficiency (VOUT = 9 V)

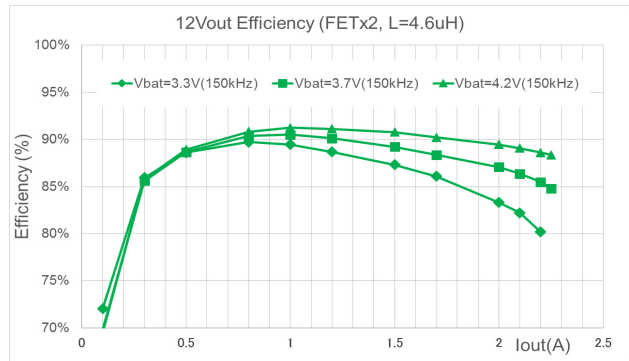

Figure 27. Boost Efficiency (VOUT = 12 V)

ADJUSTABLE PARAMETERS

This device can adjust the parameters with Port configuration or Software configuration. Adjustable parameters with Port configuration are limited. Software configuration can adjust more parameters than Port configuration.

Port Configuration

Port configuration can adjust parameters according to the resistance that is connected to FGADJ port. Refer to Table 11 and Table 12. The parameters which can't set in

Port configuration follow to the default value of Software configuration.

Software Configuration

Software configuration changes the Reference software to adjust parameters. Refer to Table 13 about adjustable parameters. When Software configuration is implemented, FGADJ port resistor for Port configuration is invalid. Please contact ON Semiconductor about how to use Software configuration.

Table 11. PORT CONFIGURATION

Parameter	Symbol	Unit	Parameter Range	Description
Design Capacity	DC	mAh	2000–24400	Sets the Design capacity of battery. It follows the resistance of connected resistor to the FGADJ port. Refer to Table 12. It is used for Battery level gauging.
Constant Charge Current	I _{CHG}	mA	2000–6000	Constant charge current is equal to 1C current of set Design capacity. If the current exceeds the range, the lower or upper value is set. (ex. Design capacity = 4,000 mAh → Constant charge current = 4,000 mA, Design capacity = 10,000 mAh → Constant charge current = 6,000 mA)
Pre-charge Current	I _{PRE}	mA	200–500	Pre-charge current is equal to 0.07C current of set Design capacity. If the current exceeds the range, the lower or upper value is set. (ex. Design capacity = 4,000 mAh → Pre-charge current = 280 mA, Design capacity = 2,000 mAh → Pre-charge current = 200 mA)
Termination Current	I _{TERM}	mA	200–800	Termination current is equal to 0.05C current of set Design capacity. If the current exceeds the range, the lower or upper value is set. (ex. Design capacity = 4,000 mAh → Termination current = 200 mA, Design capacity = 20,000 mAh → Termination current = 800 mA)

NOTE: Reference software operates this IC according to the values set in this table. There are typical values.

Table 12. FGADJ PORT RESISTOR VS DESIGN CAPACITY IN PORT CONFIGURATION

Resistance (kΩ)	Design Capacity (mAh)	Resistance (kΩ)	Design Capacity (mAh)	Resistance (kΩ)	Design Capacity (mAh)	Resistance (kΩ)	Design Capacity (mAh)
4.7	2000	18	4100	68	8600	270	17800
5.6	2200	22	4600	82	9500	330	19800
6.8	2400	27	5100	100	10600	390	22000
8.2	2700	33	5600	120	11700	470	24400
10	3000	39	6300	150	13000	–	–
12	3300	47	6900	180	14500	–	–
15	3700	56	7700	220	16100	–	–

NOTE: The tolerance level of the resistor should be less than 1%.

Table 13. SOFTWARE CONFIGURATION

Parameter		Symbol	Pin	Unit	Parameter Range	Default Value	Description
Buck Charge Conditions (Note 4)	Design capacity	DC	–	mAh	2000–24400	9600	Battery capacity range
	Pre-charge current	I _{PRE}	SENB+ SENB–	mA	200–500	400	
	Constant charge current	I _{CHG}			1000–6000	3000	
	Termination current	I _{TERM}			200–800	288	
	Termination Battery Voltage	V _{CHG}	VBAT	mV	4200 or 4350	4200	Set 4.2 V or 4.35 V. It selects Termination battery voltage and battery profile to gauge battery level.
	Continuous battery charging time	T _{CMAX}	–	min	120–1440	900	
	Hot temperature to stop Buck charge	T _{HOT}	–	0.1K	2732–3532 > T _{WARM}	3332 (60°C)	
	Warm temperature to weak Buck charge	T _{WARM}	–		2732–3532 > T _{COOL}	3182 (45°C)	
	Cool temperature to weak Buck charge	T _{COOL}	–		2732–3532 > T _{COLD}	2832 (10°C)	
	Cold temperature to stop Buck charge	T _{COLD}	–		2732–3532	2732 (0°C)	
Boost Charge Conditions (Note 4)	Boost termination current	I _{BTERM}	SENV1+ SENV2+ SENV3+ SENV–	mA	30–1000	200	
	Hot temperature to stop Boost charge	T _{HOT2}	–	0.1K	2532–3532 > T _{COLD2}	3332 (60°C)	
	Cold temperature to stop Boost charge	T _{COLD2}	–	0.1K	2532–3532	2532 (–20°C)	
Protection (Note 4)	Buck VBUS under voltage threshold	V _{BUVP}	VBUS1	mV	4400–4600	4400	USB1
	Buck VBUS over voltage threshold	V _{BOVP}	VBUS1		5250–6500	5600	USB1
	Boost VBUS under voltage threshold	V _{BUVP}	VBUS1 VB2DET		4400–4750	4400	USB1 USB2
			VB3DET		4400–4750	4400	USB3 For External Boost IC
	Boost VBUS over voltage threshold	V _{BOVP}	VBUS1 VB2DET		5200–5600	5600	5 V mode
					9800–13500	10200	9 V mode
					13100–13500	13500	12 V mode
					13100–13500	13500	Continuous mode
			VB3DET		5200–5600	5600	USB3 For External Boost IC
	Boost over current threshold	I _{OUTOCP}	SENV1+ SENV2+ SENV–		1500–3000	3000	V _{out} ≤ 7.5 V
1500–3000				2300	7.5 V < V _{out} ≤ 10.5 V		
1500–2500				1800	10.5 V < V _{out}		
SENV3+ SENV–			1500–3000	2400	USB3 For External Boost IC		

LC709511F

Table 13. SOFTWARE CONFIGURATION (continued)

Parameter		Symbol	Pin	Unit	Parameter Range	Default Value	Description
Thermistor (Note x4)	Constant B	CB	–	K	2600–4700	3300	Set the B–constant of NTC thermistor. Refer to the specification of thermistor to fix the value.
Smart DCP Divided Mode (Note 5)	USB3+/- initial voltage	VD_27 VD_20	USB3+ USB3–	–	0 or 1 or 2	2	Initial USB3+/- voltage after connection 0: 2.7 V/2.0 V for 2.1 A 1: 2.0 V/2.7 V for 1 A 2: 2.7 V/2.7 V for 2.4 A
Type–C (Note 5)	CC1A and CC2A current source in Attached.SRC	Rp_80 Rp_180 Rp_330	CC1A CC2A	–	1 or 2 or 3	3	1: Rp for default (80 μ A) 2: Rp for 1.5 A (180 μ A) 3: Rp for 3 A (330 μ A)

4. Reference software operates this IC according to the values set in this table. There are typical values.

5. Refer to the Electrical Characteristics table.

LC709511F

BILL OF MATERIAL

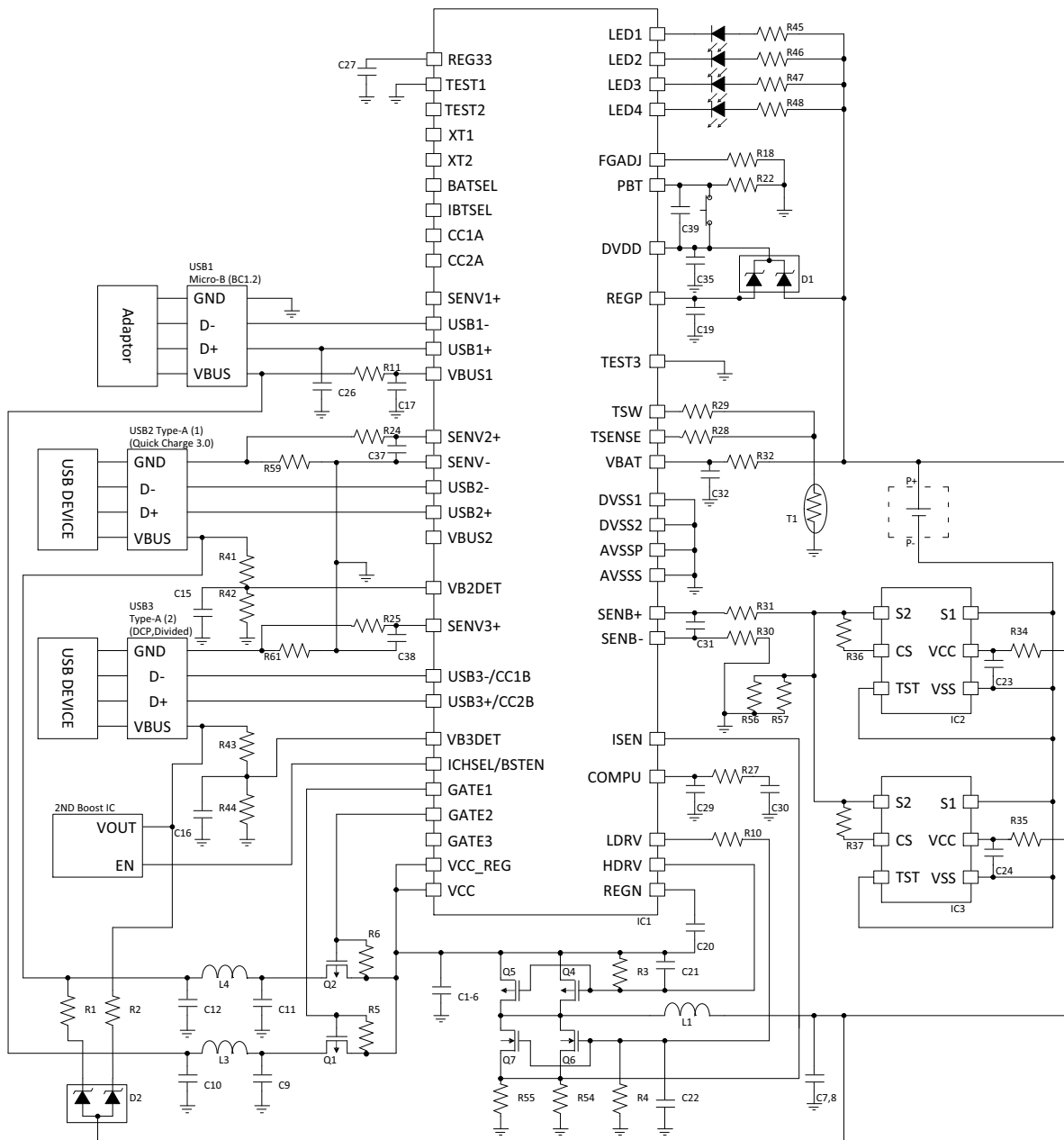

Figure 28. Reference Software: FW02 Parts Example

LC709511F

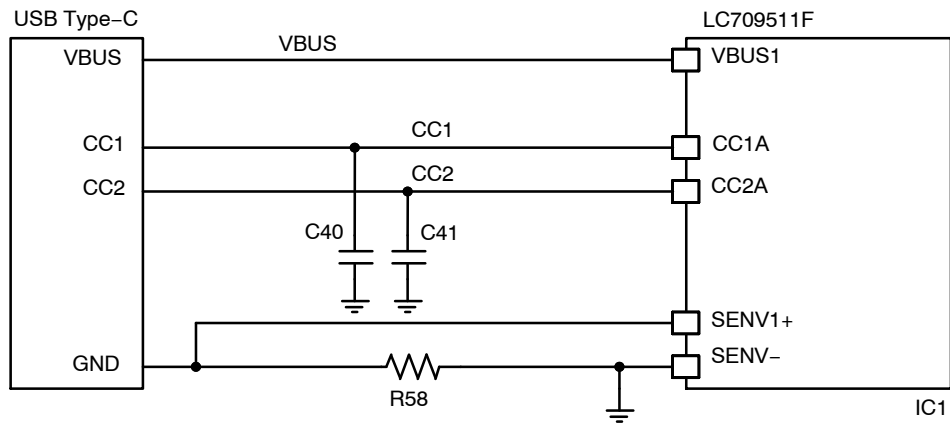

Figure 29. Reference Software: FW05 Parts Example around CC

Table 14. BILL OF MATERIALS

Designator	Description	Value	Tolerance	Manufacturer	Manufacturer Part Number
IC1	Charge control LSI	-	-	ON Semiconductor	LC709511F
IC2, 3	Lib Protection	-	-	ON Semiconductor	LC06111TMT
Q6, 7	Nch FET	-	-	ON Semiconductor	NTTFS4H05N
Q1, 2, 4, 5	Pch FET	-	-	ON Semiconductor	ECH8310
D1	Schottky diode (Note 6)	-	-	ON Semiconductor	BAT54CL
D2	Schottky diode (Note 6)	-	-	ON Semiconductor	BAT54AL
L1	INDUCTOR COIL	4.6 μ H	-	Panasonic	ETQP6F4R6HFA
L3, 4	Ferrite Bead	30 Ω	-	MURATA	BLM21PG300SN1
T1	NTC Thermistor	10 k Ω	-	SEMITEC	103JT-025
C21, 22	Ceramic Capacitor 16 V	1 pF	-		
C40, 41	Ceramic Capacitor 10 V	390 pF	-		
C39	Ceramic Capacitor 10 V	1000 pF	-		
C29	Ceramic Capacitor 16 V	1000 pF	-		
C30	Ceramic Capacitor 16 V	22000 pF	-		
C36-38	Ceramic Capacitor 10 V	0.01 μ F	-		
C23, 24, 31	Ceramic Capacitor 10 V	0.1 μ F	-		
C10,12, 15, 16	Ceramic Capacitor 16 V	0.1 μ F	-		
C19, 26, 27, 32, 35, 42	Ceramic Capacitor 10 V	1 μ F	-		
C17, 20	Ceramic Capacitor 16 V	1 μ F	-		
C1-6, 9, 11	Ceramic Capacitor 16 V	22 μ F	-	MURATA	GRM32EB31C226ME16
C7, 8	Ceramic Capacitor 10 V	47 μ F	-	MURATA	GRM32ER61C476KE15
R11, 23-25, 28, 30-32	Chip resistor	100 Ω	+5%		
R45-48	Chip resistor	330 Ω	+5%		
R36, 37	Chip resistor	1 k Ω	5%		
R27	Chip resistor	2.2 k Ω	+5%		
R8, 29	Chip resistor	10 k Ω	+5%		
R22	Chip resistor	51 k Ω	5%		

LC709511F

Table 14. BILL OF MATERIALS (continued)

Designator	Description	Value	Tolerance	Manufacturer	Manufacturer Part Number
R3, 4	Chip resistor	100 kΩ	+5%		
R1, 2	Chip resistor	150 kΩ	+5%		
R44	Chip resistor	180 kΩ	+1%		
R5, 6	Chip resistor	510 kΩ	5%		
R41, 43	Chip resistor	910 kΩ	+1%		
R18	Chip resistor	4.7 kΩ – 470 kΩ	+1%		
R54–57	Chip resistor 1 W	10 mΩ	+1%	Panasonic	ERJ8BWFR010V
R58, 59, 61	Chip resistor 1 W	20 mΩ	+1%	Panasonic	ERJ8BWFR020V

6. Forward voltage of Schottky diode must be under 0.3 V with 5 mA at 25°C.

Caution:

This device is made for power applications.
Please execute appropriate test and take safety measures on your board.

Quick Charge is a trademark of Qualcomm Technologies, Inc.,

MECHANICAL CASE OUTLINE

PACKAGE DIMENSIONS

ON Semiconductor®

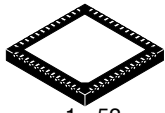

1 52
SCALE 2:1

QFN52 6x6, 0.4P
CASE 485BE
ISSUE B

DATE 23 JUN 2010

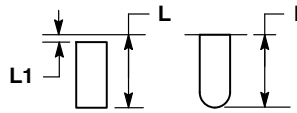
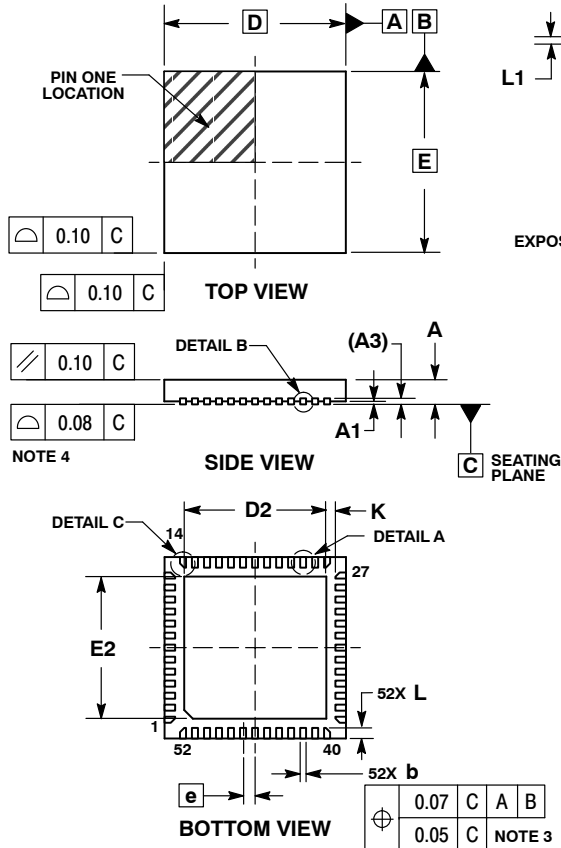

DETAIL A
ALTERNATE TERMINAL
CONSTRUCTIONS

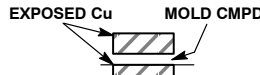

DETAIL B
ALTERNATE
CONSTRUCTION

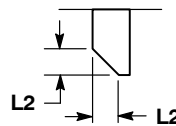

DETAIL C
8 PLACES

NOTES:

1. DIMENSIONING AND TOLERANCING PER ASME Y14.5M, 1994.
2. CONTROLLING DIMENSIONS: MILLIMETERS.
3. DIMENSION b APPLIES TO PLATED TERMINAL AND IS MEASURED BETWEEN 0.15 AND 0.30mm FROM TERMINAL TIP
4. COPLANARITY APPLIES TO THE EXPOSED PAD AS WELL AS THE TERMINALS.

MILLIMETERS		
DIM	MIN	MAX
A	0.80	1.00
A1	0.00	0.05
A3	0.20	REF
b	0.15	0.25
D	6.00	BSC
D2	4.60	4.80
E	6.00	BSC
E2	4.60	4.80
e	0.40	BSC
K	0.30	REF
L	0.25	0.45
L1	0.00	0.15
L2	0.15	REF

GENERIC MARKING DIAGRAM*

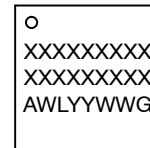

- XXX = Specific Device Code
- A = Assembly Location
- WL = Wafer Lot
- YY = Year
- WW = Work Week
- G = Pb-Free Package

*This information is generic. Please refer to device data sheet for actual part marking. Pb-Free indicator, "G" or microdot "▪", may or may not be present.

SOLDERING FOOTPRINT*

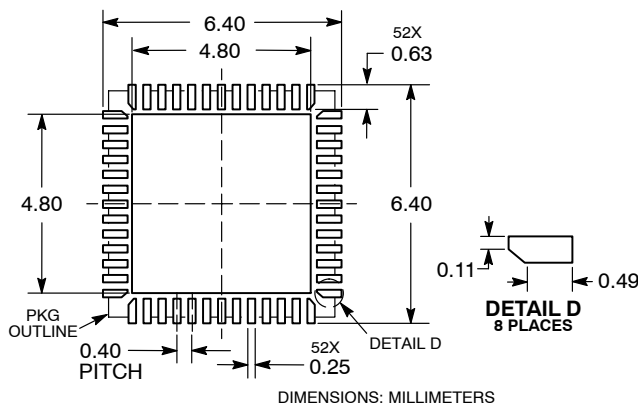

*For additional information on our Pb-Free strategy and soldering details, please download the ON Semiconductor Soldering and Mounting Techniques Reference Manual, SOLDERRM/D.

DOCUMENT NUMBER:	98AON47515E	Electronic versions are uncontrolled except when accessed directly from the Document Repository. Printed versions are uncontrolled except when stamped "CONTROLLED COPY" in red.
DESCRIPTION:	QFN52, 6x6, 0.4MM PITCH	PAGE 1 OF 1

ON Semiconductor and ON are trademarks of Semiconductor Components Industries, LLC dba ON Semiconductor or its subsidiaries in the United States and/or other countries. ON Semiconductor reserves the right to make changes without further notice to any products herein. ON Semiconductor makes no warranty, representation or guarantee regarding the suitability of its products for any particular purpose, nor does ON Semiconductor assume any liability arising out of the application or use of any product or circuit, and specifically disclaims any and all liability, including without limitation special, consequential or incidental damages. ON Semiconductor does not convey any license under its patent rights nor the rights of others.

ON Semiconductor and  are trademarks of Semiconductor Components Industries, LLC dba ON Semiconductor or its subsidiaries in the United States and/or other countries. ON Semiconductor owns the rights to a number of patents, trademarks, copyrights, trade secrets, and other intellectual property. A listing of ON Semiconductor's product/patent coverage may be accessed at www.onsemi.com/site/pdf/Patent-Marking.pdf. ON Semiconductor reserves the right to make changes without further notice to any products herein. ON Semiconductor makes no warranty, representation or guarantee regarding the suitability of its products for any particular purpose, nor does ON Semiconductor assume any liability arising out of the application or use of any product or circuit, and specifically disclaims any and all liability, including without limitation special, consequential or incidental damages. Buyer is responsible for its products and applications using ON Semiconductor products, including compliance with all laws, regulations and safety requirements or standards, regardless of any support or applications information provided by ON Semiconductor. "Typical" parameters which may be provided in ON Semiconductor data sheets and/or specifications can and do vary in different applications and actual performance may vary over time. All operating parameters, including "Typicals" must be validated for each customer application by customer's technical experts. ON Semiconductor does not convey any license under its patent rights nor the rights of others. ON Semiconductor products are not designed, intended, or authorized for use as a critical component in life support systems or any FDA Class 3 medical devices or medical devices with a same or similar classification in a foreign jurisdiction or any devices intended for implantation in the human body. Should Buyer purchase or use ON Semiconductor products for any such unintended or unauthorized application, Buyer shall indemnify and hold ON Semiconductor and its officers, employees, subsidiaries, affiliates, and distributors harmless against all claims, costs, damages, and expenses, and reasonable attorney fees arising out of, directly or indirectly, any claim of personal injury or death associated with such unintended or unauthorized use, even if such claim alleges that ON Semiconductor was negligent regarding the design or manufacture of the part. ON Semiconductor is an Equal Opportunity/Affirmative Action Employer. This literature is subject to all applicable copyright laws and is not for resale in any manner.

PUBLICATION ORDERING INFORMATION

LITERATURE FULFILLMENT:

Email Requests to: orderlit@onsemi.com

ON Semiconductor Website: www.onsemi.com

TECHNICAL SUPPORT

North American Technical Support:
Voice Mail: 1 800-282-9855 Toll Free USA/Canada
Phone: 011 421 33 790 2910

Europe, Middle East and Africa Technical Support:

Phone: 00421 33 790 2910

For additional information, please contact your local Sales Representative