

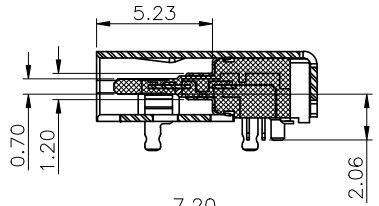

REV.	ECN NO OR DESCRIPTION	REVISED	DATE

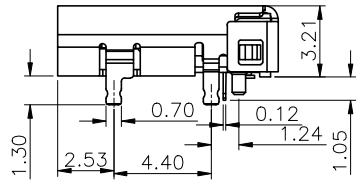
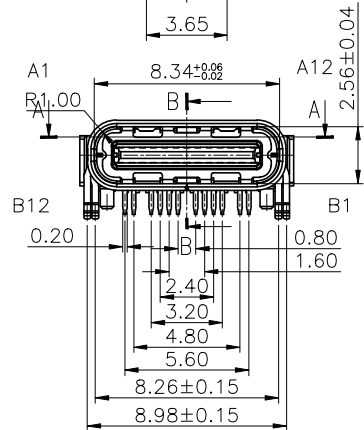
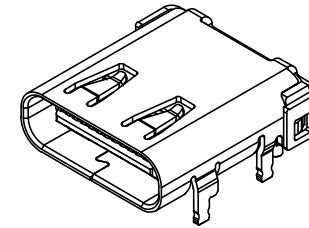
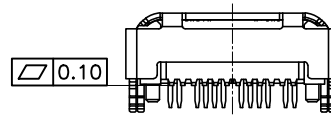
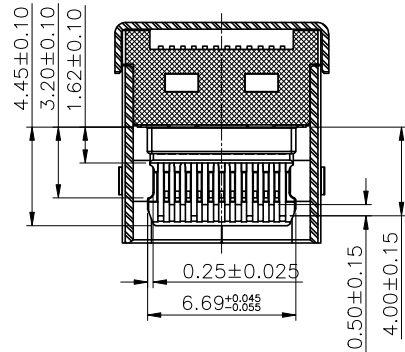
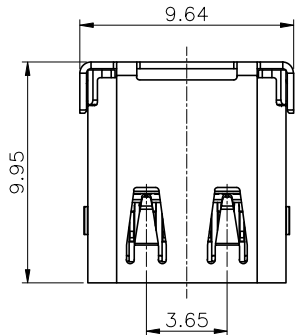

A1	GND	B12	GND
A2	SSTXP1	B11	SSRXP1
A3	SSTXN1	B10	SSRXN1
A4	VBUS	B9	VBUS
A5	CC1	B8	SBU2
A6	DP1	B7	DN2
A7	DN1	B6	DP2
A8	SBU1	B5	CC2
A9	VBUS	B4	VBUS
A10	SSRXN2	B3	SSTXN2
A11	SSRXP2	B2	SSTXP2
A12	GND	B1	GND
PIN	SIGNAL NAME	PIN	SIGNAL NAME

NOTE:

1. MATERIAL:

- 1.1 INSULATOR: HIGH TEMPERATURE PLASTIC UL 94 V-0; Black Color
- 1.2 CONTACT: C7025 (T=0.12mm)
- 1.3 SHELL: STAINLESS STEEL (T=0.30mm)
- 1.4 INNER GROUND COVER SHELL: STAINLESS STEEL (T=0.10mm)
- 1.5 MID PLATE: STAINLESS STEEL (T=0.15mm)

2. ELECTRICAL CHARACTERISTICS:

- 2.1 CONTACT RESISTANCE: 30mΩ Max FOR INITIAL, 10mΩ CHANGE AFTER TEST. MEASURE AT 20mV, 100mA
- 2.2 CONTACT CURRENT RATING: 5A FOR COLLECTIVELY POWER SUPPLY
- 2.3 DIELECTRIC WITHSTANDING VOLTAGE: 100V AC R.M.S.
- 2.4 INSULATION RESISTANCE 100MΩ Min
- 2.5 OPERATING TEMPERATURE: -40° C ~ 85° C

3. MECHANICAL CHARACTERISTICS:

- 3.1 MATING FORCE: 5*20 N
- 3.2 UNMATED FORCE: 8*20N INITIAL TEST; 6*20N DURABILITY AFTER TEST
- 3.3 DURABILITY: 10,000 CYCLES

4. PLATING

- 4.1 TERMINAL CONTACT: 1u" GOLD PLATING ON CONTACT AREA, ALL OVER 50u" Min NICKEL AND 1u" Min Matte GOLD ALL OVER 50u" Min NICKEL ON SOLDER AREA
- 4.2 SHELL: 50u" Min. NICKEL ALL OVER,
- 4.3 INNER GROUND COVER SHELL: CLEAN
- 4.4 MID PLATE: CLEAN

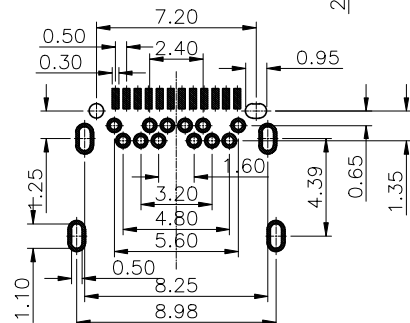
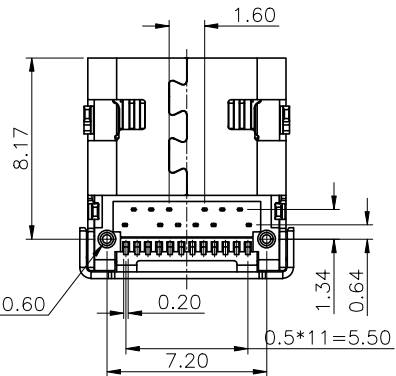

RECOMMENDED P.C.B LAYOUT
TOP VIEW (TOLERANCE ±0.05)

UNLESS OTHERWISE
SPECIFIED TOLERANCES

DECIMALS: .X±0.15 .XX±0.05 .XXX±0.02
ANGLES: X.±5° X.±2° .XX±1°



东莞市汉博电子科技有限公司
DONGGUAN HANBO TECHNOLOGY CO., LTD

TITLE	TYPE C DIP+SMT TYPE 24PIN			
DWN	xiong	PART NO. MC-308		
CHKD	lee	SCALE: 1:1	UNIT: mm	
APVD	wang	SIZE: A4	SHEET: 1 OF 1	REV: A4

CUSTOMER COPY