

ITEM	H	
01	3.8	✓
02	4.0	
03	4.3	
04	5.0	
05	6.0	
05	6.5	
05	7.0	
05	8.0	

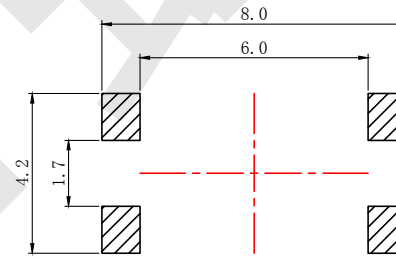

P. C. B. Layout

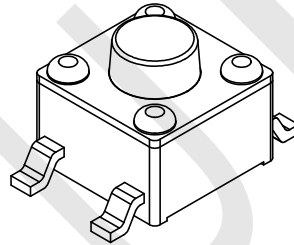
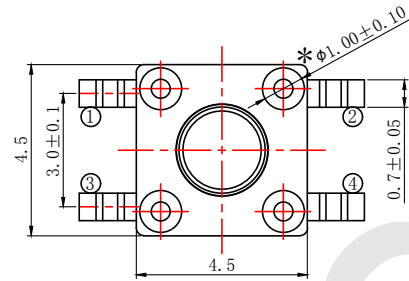
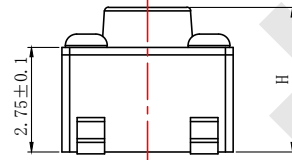
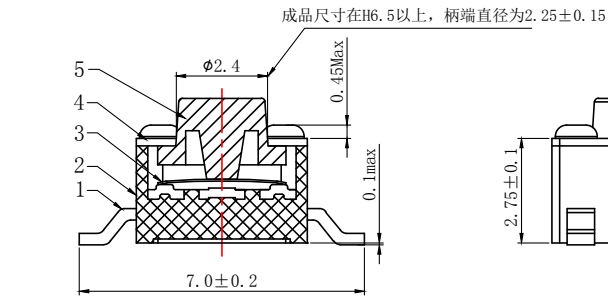
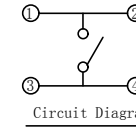

- Remarks:
1. Rated current, Voltage: DC 12V 50mA
 2. Contact resistance: $\leq 50m\Omega$
 3. Insulation resistance: $\geq 100M\Omega$
 4. The intensity of operations: $250 \pm 50gf$
 5. Life requirements: 100000 times
 6. Withstand voltage: AC250V 1 minute
 7. All materials comply with RoHS2.0 standards

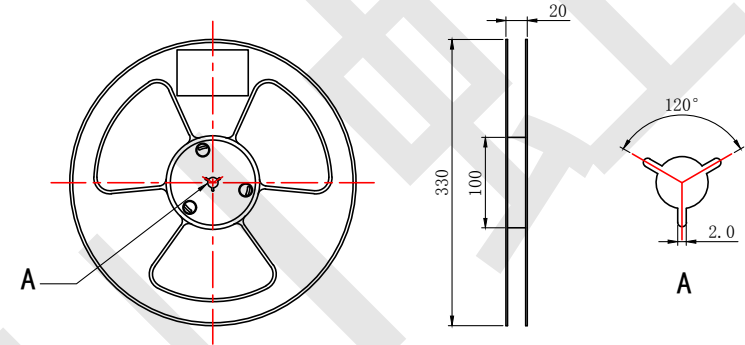
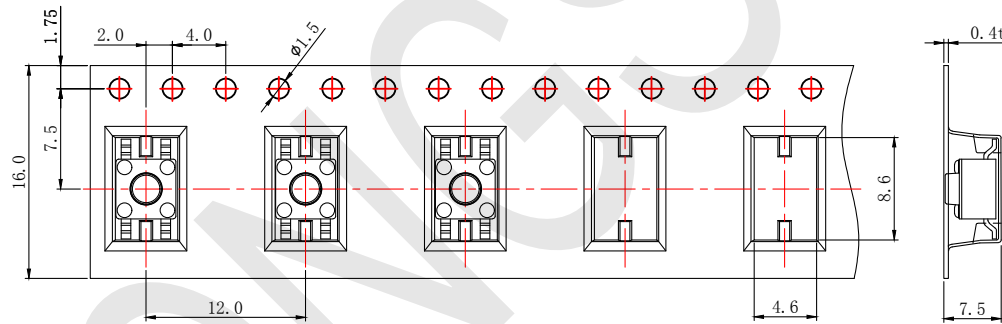

- Remarks:
1. The number of tapes per volume is 800 PCS;
 2. Braiding process, can not be caused by carrying half crushed;
 3. Pay attention to the direction of the tape, with a clockwise direction out of the carrier tape, with a hole in the top or right

NO.	PART NAME	MATERIAL	QTY	FINISHING	General Tolerance	DRAWN	YANGBIAO	Product Name	Tact switch
5	Button	PPA	1	Black	$X \leq 1$	±0.05	AFFIRM	YANGGUOQUAN	Model Number
4	Cover	Brass	1	Ni Plating	$1 \leq X \leq 5$	±0.10	AUDITING		DATE
3	Shrapnel	SUS	1	Ag Plating	$5 \leq X \leq 10$	±0.15			2018-09-22
2	Housing	PPA	1	Black	$X > 10$	±0.25	SHEET	1:1 UNIT mm	
1	Terminal	Brass	4	Ag Plating	ANGLE	±3°			
					Zhejiang Hongsui Precision Electronics Co., Ltd.				