

Version	ECM	Amendments	Modifier	Date Modified
A/0				

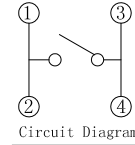

P. C. B. Layout

- Remarks:
1. Rated current, Voltage: DC 12V 50mA
  2. Contact resistance:  $\leq 100m\Omega$
  3. Insulation resistance:  $\geq 100M\Omega$
  4. The intensity of operations:  $160 \pm 50gf$
  5. Life requirements: 100000次
  6. Withstand voltage: AC250V 1分钟
  7. All materials comply with RoHS standards

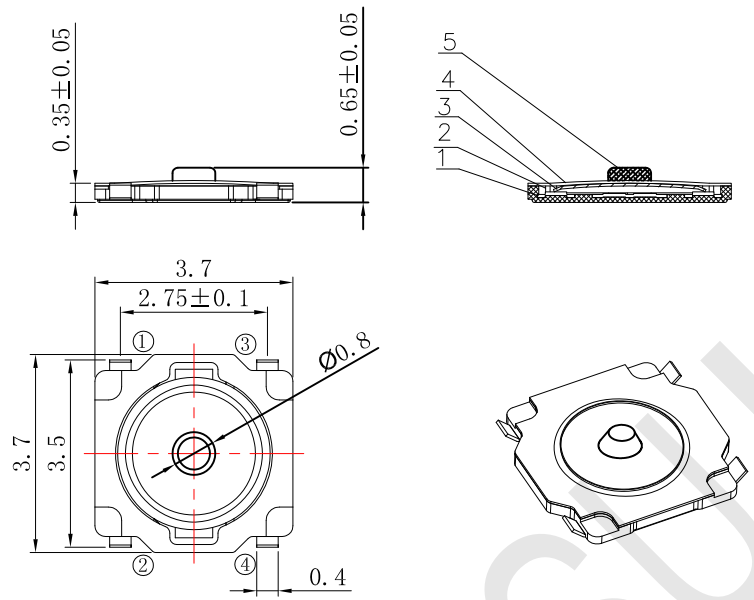
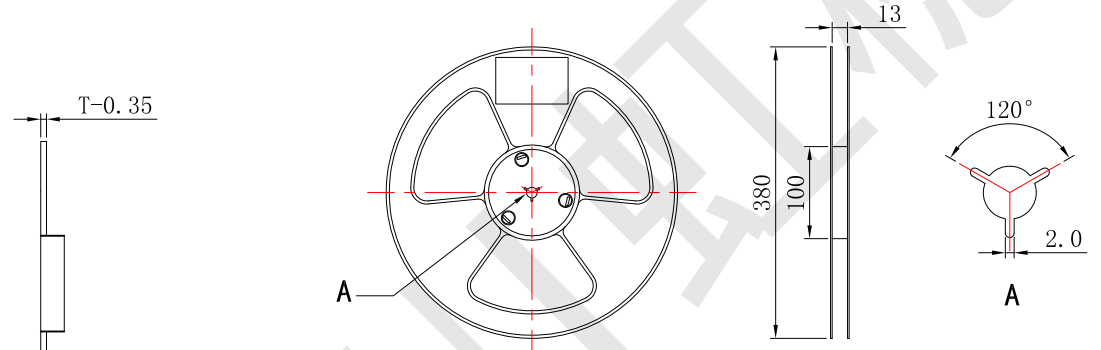
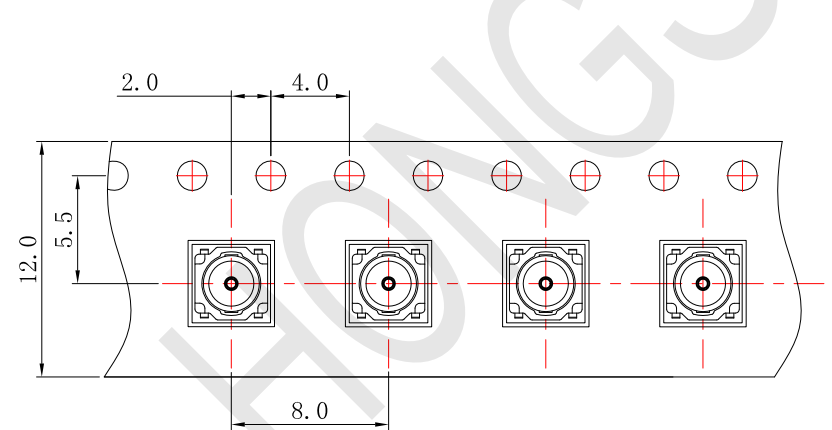

- Remarks:
- 1, The number of tapes per volume is 10000 PCS;
  - 2, Braiding process, can not be caused by carrying half crushed;
  - 3, Pay attention to the direction of the tape, with a clockwise direction out of the carrier tape, with a hole in the top or right

NO.	PART NAME	MATERIAL	QTY	FINISHING	General	Tolerance	DRAWN	郑杰铭	Product Name	Tact switch
5	Button	Polyimide	1	Black	$X \leq 1$	$\pm 0.05$	AFFIRM	徐丹丹	Model Number	TS37AB65A16B001
4	Paster	Polyimide	1	Yellow	$1 \leq X \leq 5$	$\pm 0.10$	AUDITING	杨书胜	DATE	2021-04-02
3	Shrapnel	SUS	1	Ag Plating	$5 \leq X \leq 10$	$\pm 0.15$	SHEET	1:1	UNIT	mm
2	Housing	LCP	1	Black	$X > 10$	$\pm 0.25$				
1	Terminal	Phosphor copper	4	Ag Plating	ANGLE	$\pm 3^\circ$				
<b>ZHEJIANG HONGSUI PRECISION ELECTRONIC CO., LTD</b>										

