

Version	ECM	Amendments	Modifier	Date Modified
A/0				

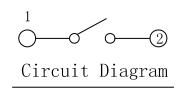

- Remarks:
1. Rated current, Voltage: DC 12V 50mA
 2. Contact resistance: $\leq 100m\Omega$
 3. Insulation resistance: $\geq 100M\Omega$
 4. The intensity of operations: $300 \pm 50gf$
 5. Life requirements: 100000 times
 6. Withstand voltage: AC250V 1 minute
 7. All materials comply with RoHS standards

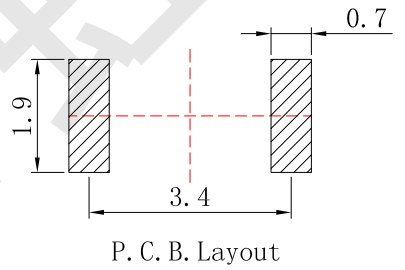
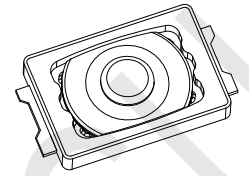
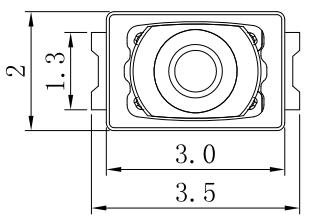
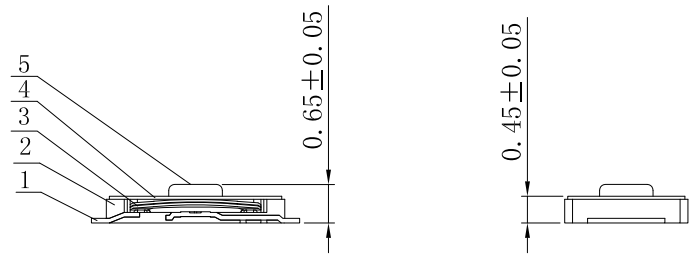
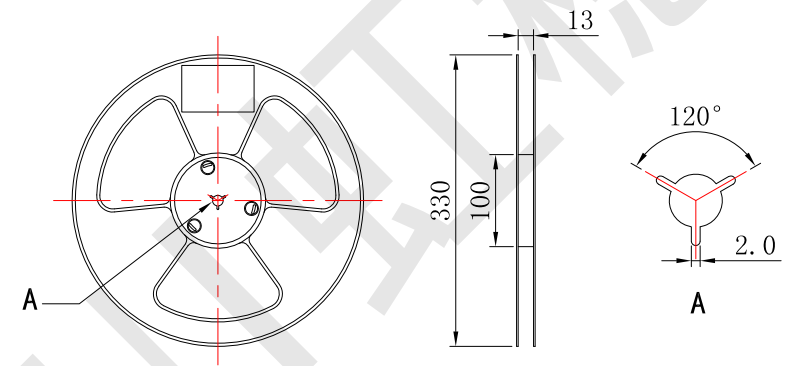
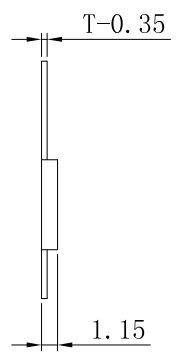
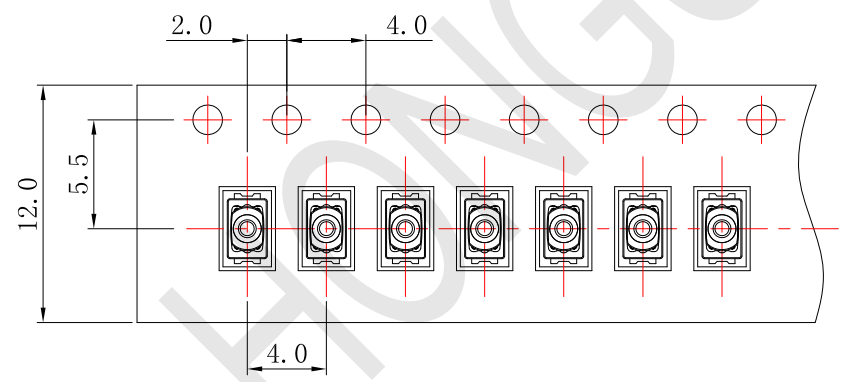

- Remarks:
- 1, The number of tapes per volume is 10000 PCS;
 - 2, Braiding process, can not be caused by carrying half crushed;
 - 3, Pay attention to the direction of the tape, with a clockwise direction out of the carrier tape, with a hole in the top or right

NO.	PART NAME	MATERIAL	QTY	FINISHING	General	Tolerance	DRAWN	YANGBIAO	Product Name	Tact switch
5	Button	Polyimide	1	Yellow	$X \leq 1$	± 0.05	AFFIRM	YANGGUOQUAN	Model Number	TS20AD65A30B011
4	Paster	Polyimide	1	Yellow	$1 \leq X \leq 5$	± 0.10	AUDITING		DATE	2016-06-08
3	Shrapnel	SUS	2	Ag Plating	$5 \leq X \leq 10$	± 0.15				
2	Housing	PPA	1	Black	$X > 10$	± 0.25	SHEET	1:1 UNIT mm		
1	Terminal	Phosphor copper	2	Ag Plating	ANGLE	$\pm 3^\circ$				