

P- Channel 60-V (D-S) MOSFET

GENERAL DESCRIPTION

The ME20P06 is the P-Channel logic enhancement mode power field effect transistors are produced using high cell density, DMOS trench technology. This high density process is especially tailored to minimize on-state resistance. These devices are particularly suited for low voltage application such as cellular phone and notebook computer power management and other battery powered circuits , and low in-line power loss are needed in a very small outline surface mount package.

PIN CONFIGURATION

(TO-252-3L)

Top View

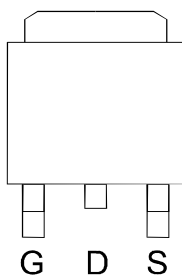

FEATURES

- $R_{DS(ON)} \leq 78m\Omega @ V_{GS} = -10V$
- $R_{DS(ON)} \leq 100m\Omega @ V_{GS} = -4.5V$
- Super high density cell design for extremely low $R_{DS(ON)}$
- Exceptional on-resistance and maximum DC current capability

APPLICATIONS

- Power Management in Note book
- DC/DC Converter
- Load Switch
- LCD Display inverter

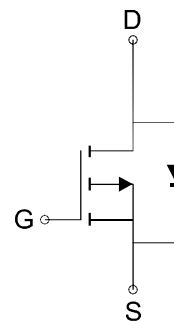

P-Channel MOSFET

Ordering Information: ME20P06 (Pb-free)

ME20P06-G (Green product-Halogen free)

Absolute Maximum Ratings (TA=25°C Unless Otherwise Noted)

Parameter	Symbol	Rating	Unit
Drain-Source Voltage	V_{DS}	-60	V
Gate-Source Voltage	V_{GS}	± 20	V
Continuous Drain Current (Tj=150°C)*	I_D	Tc=25°C	-17.7
		Tc=70°C	-14.1
Pulsed Drain Current	I_{DM}	-71	A
Maximum Power Dissipation*	P_D	Tc=25°C	39.1
		Tc=70°C	25
Operating Junction Temperature	T_J	-55 to 150	°C
Thermal Resistance-Junction to Case*	$R_{\theta JC}$	3.2	°C/W

*The device mounted on 1in² FR4 board with 2 oz copper

P- Channel 60-V (D-S) MOSFET

Electrical Characteristics (TA=25°C Unless Otherwise Specified)

Symbol	Parameter	Limit	Min	Typ	Max	Unit
STATIC						
V _{(BR)DSS}	Drain-Source Breakdown Voltage	V _{GS} =0V, I _D =-250 μA	-60			V
V _{GS(th)}	Gate Threshold Voltage	V _{DS} =V _{GS} , I _D =-250 μA	-1		-3	V
I _{GSS}	Gate Leakage Current	V _{DS} =0V, V _{GS} =±20V			±100	nA
I _{DSS}	Zero Gate Voltage Drain Current	V _{DS} =-60V, V _{GS} =0V			1	μA
R _{DS(ON)}	Drain-Source On-State Resistance ^a	V _{GS} =-10V, I _D = -20A		65	78	mΩ
		V _{GS} =-4.5V, I _D = -16A		80	100	
V _{SD}	Diode Forward Voltage	I _S =-20A, V _{GS} =0V		1	1.2	V
DYNAMIC						
Q _g	Total Gate Charge(10V)	V _{DS} =-30V, V _{GS} =-10V, I _D =-20A		22		nC
Q _g	Total Gate Charge(4.5V)			10		
Q _{gs}	Gate-Source Charge	V _{DS} =-30V, V _{GS} =-4.5V, I _D =-20A		6.3		
Q _{gd}	Gate-Drain Charge			5		
C _{iss}	Input capacitance			958		pF
C _{oss}	Output Capacitance	V _{DS} =-15V, V _{GS} =0V, F=1MHz		100		
C _{rss}	Reverse Transfer Capacitance			33		
t _{d(on)}	Turn-On Delay Time			36		ns
t _r	Turn-On Rise Time	V _{DS} =-15V, R _L =15Ω		16		
t _{d(off)}	Turn-Off Delay Time	I _D =-1A, V _{GEN} =-10V, R _G =3Ω		53		
t _f	Turn-On Fall Time			6		

Notes: a. Pulse test: pulse width ≤ 300us, duty cycle ≤ 2%, Guaranteed by design, not subject to production testing.

b. Matsuki reserves the right to improve product design, functions and reliability without notice.

P- Channel 60-V (D-S) MOSFET
Typical Characteristics (T_J =25°C Noted)

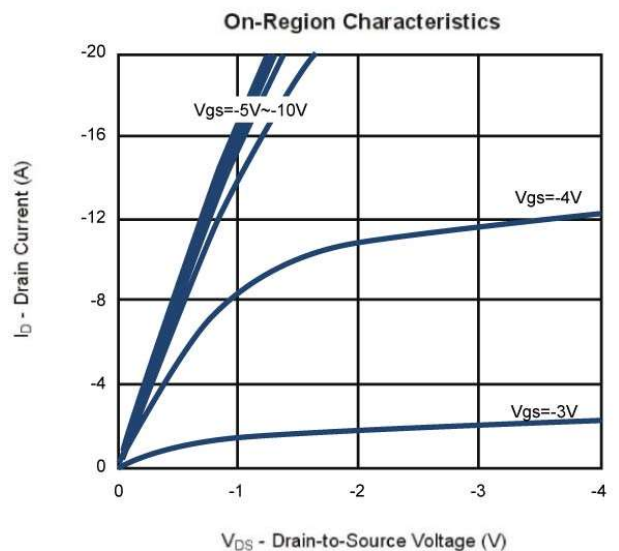
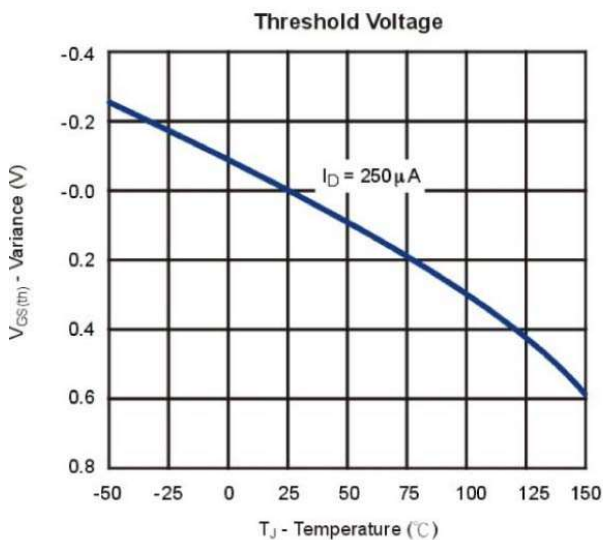
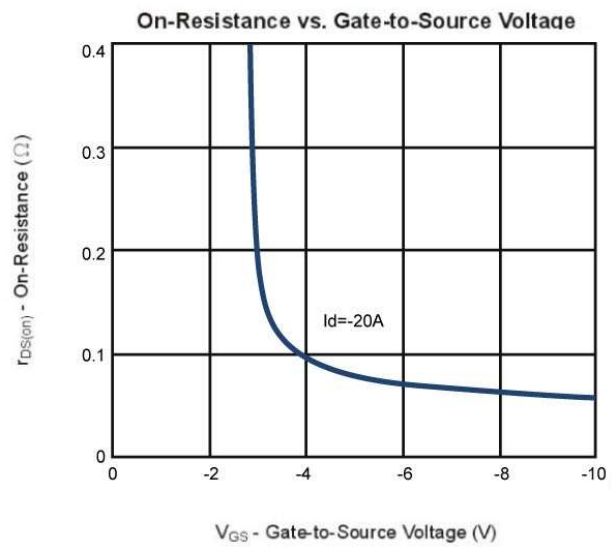
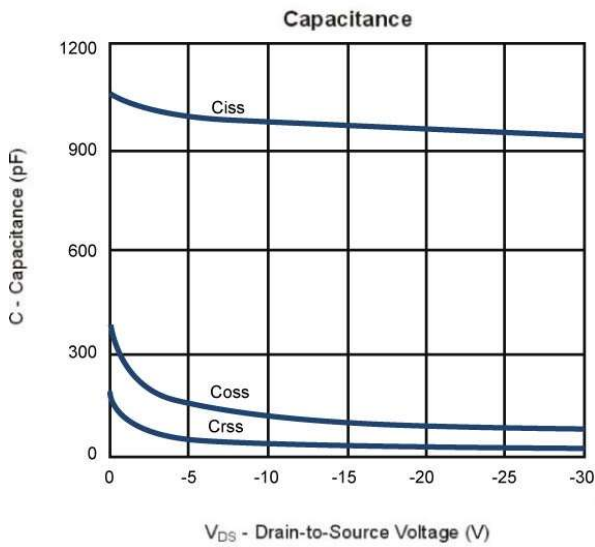
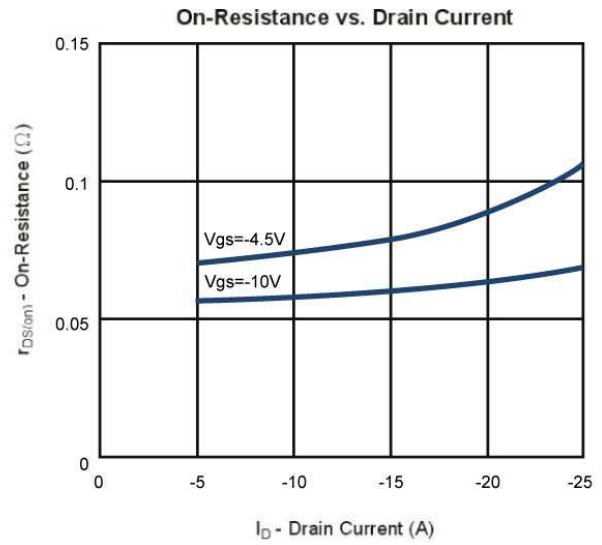
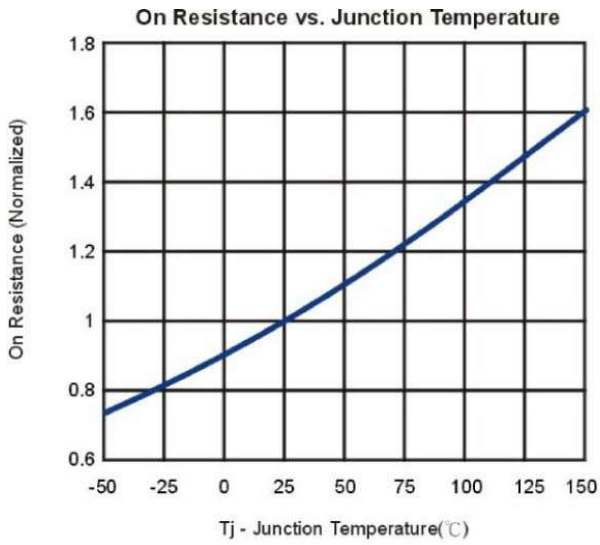

P- Channel 60-V (D-S) MOSFET
Typical Characteristics (T_J =25°C Noted)

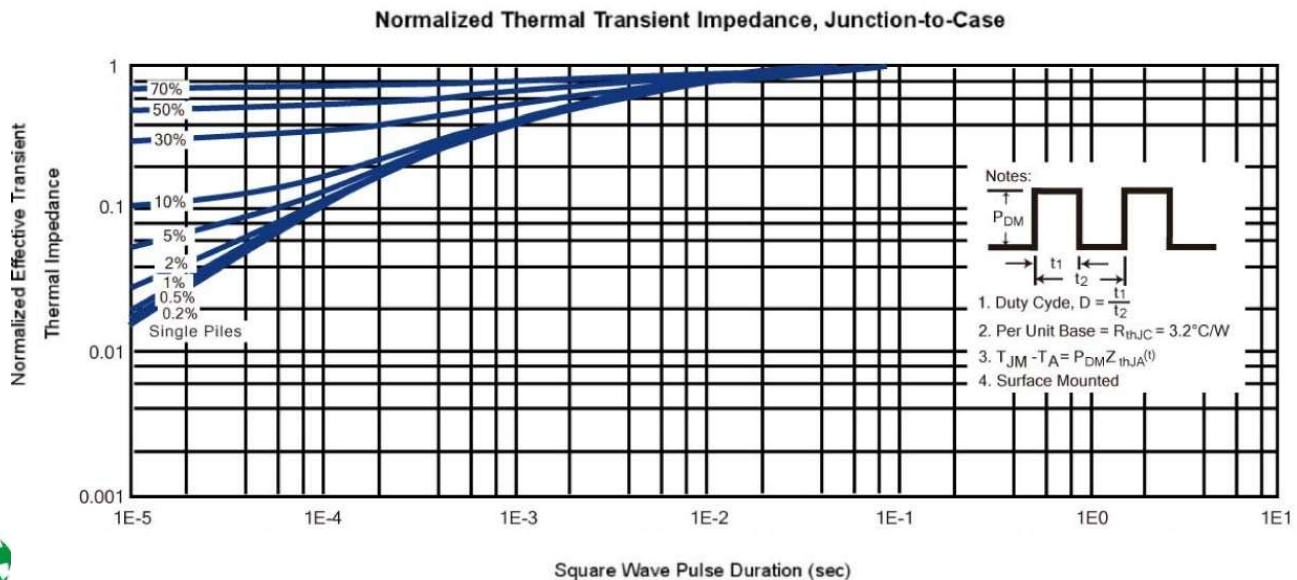
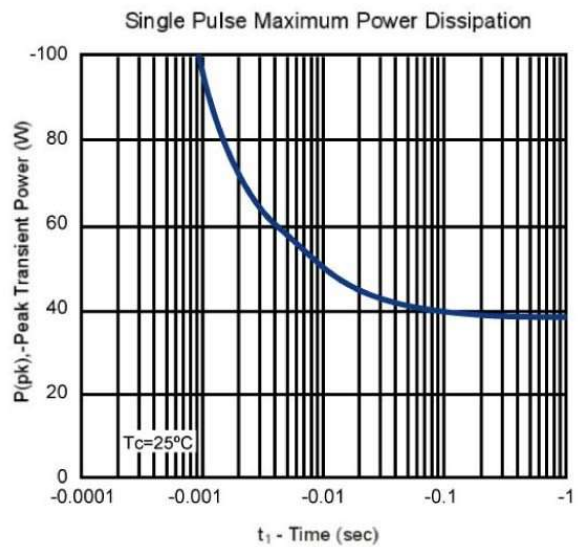
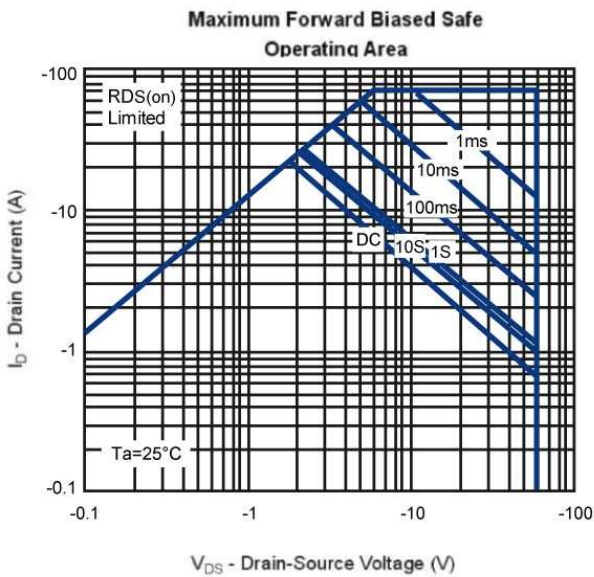
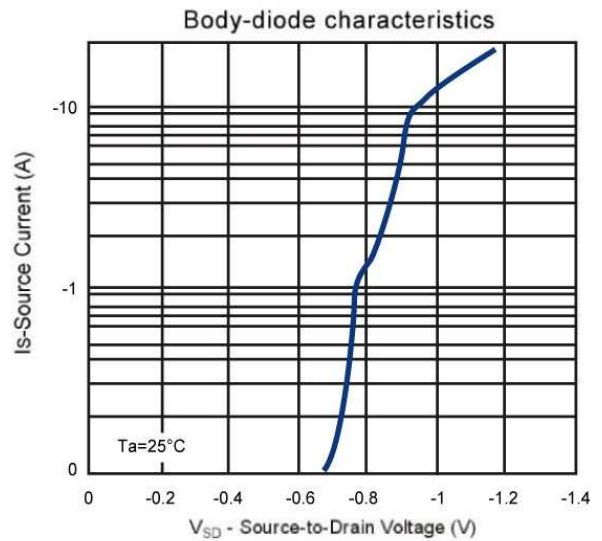
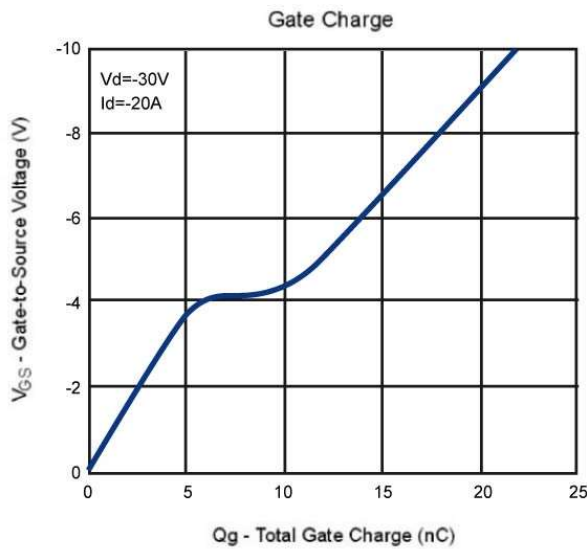

P-Channel 60-V (D-S) MOSFET

TO252-3L Package Outline

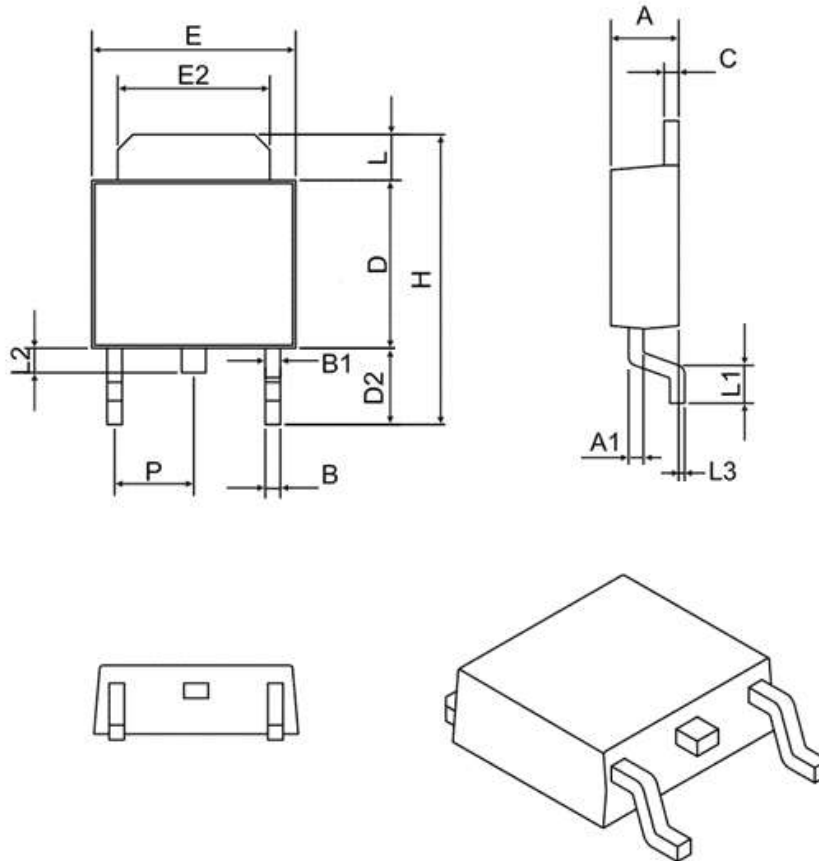

SYMBOL	MILLIMETERS (mm)	
	MIN	MAX
A	2.00	2.50
A1	0.45	0.60
B	0.50	0.88
B1	0.50	1.14
C	0.40	0.60
D	5.20	6.23
D2	2.743 REF	
H	9.40	10.50
E	6.30	6.80
E2	4.50	5.50
L	0.89	1.70
L1	0.90	1.77
L2	0.50	1.10
L3	0	0.30
P	2.286 BSC	