

REV	MARK	DESCRIPTION	DRAFTED. BY	DATE

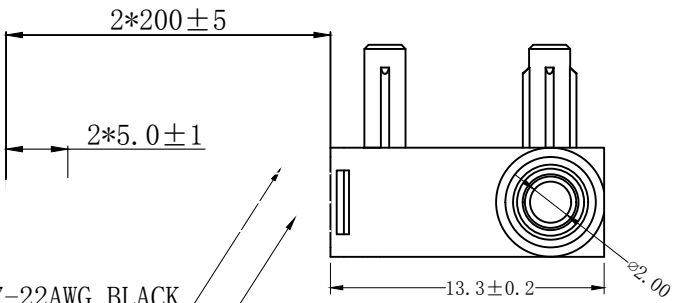

COM: UL1007-22AWG BLACK

NO: UL1007-22AWG BLUE

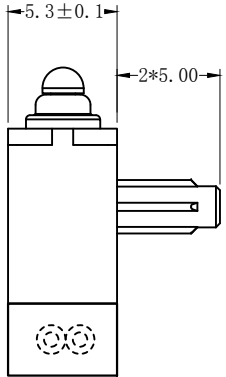
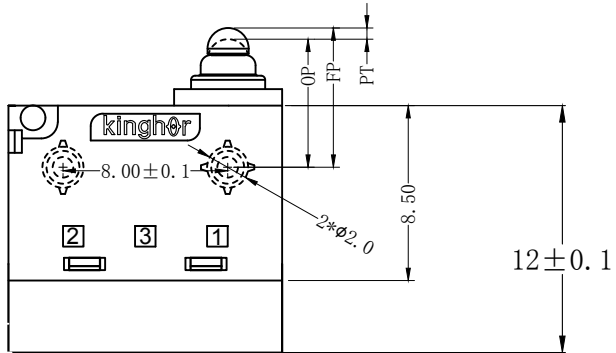

CHARACTERISTICS	
OPERATING FORCE (OF):	130gf Max.
RELEASE FORCE (RF):	30gf Min.
OPERATING POSITION:	6.4±0.5mm.
PRE TRAVEL:	1.30mm Max.
DIFFERENTIAL TRAVEL:	0.25mm Max.
FREE POSITION:	7.20mm Max.

ELECTRICAL DATA	
<b>RATING</b>	<b>OPERATING LIFE</b>
3A 12VDC	100,000 CYCLES
0.1A 48VDC 125/250VAC	100,000 CYCLES

<b>MECHANICAL LIFE</b>	<b>500,000 CYCLES</b>
<b>GAP TYPE</b>	<b>MICRO</b>
<b>OPERATING TEMP</b>	<b>-25°C ~ +85°C</b>
<b>WATERPROOF</b>	<b>IP67</b>

OUTLINE DRAWING			
<b>TITLE</b>	<b>H3 SERIES MICRO SWITCH</b>		
<b>MODEL</b>	<b>H3-D2</b>		
<b>PART NO.</b>	<b>H3-D2-1B00W2-2-200</b>		
<b>DRAFTED BY</b>	Bing wang	<b>DATE</b>	2020-12-9
<b>CHECKED BY</b>	Hua Bai	<b>DATE</b>	2020-12-9
<b>APPROVED BY</b>	Hong Chen	<b>DATE</b>	2020-12-9

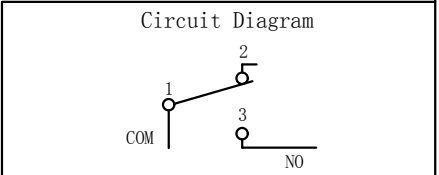

TOLERANCE UNLESS OTHERWISE SPECIFIED							
≤3	1~3	3~10	10~30	30~100	100~200	ANGLE	
±0.2	±0.3	±0.4	±0.6	±1.0	±1.5	±3.0°	
						<b>SCALE</b>	
						UNIT	mm
						VERSION REV	A1

**KINGHOR**  
SWITCHES AND CONTROL EXPERT