

REV	MARK	DESCRIPTION	DRAFTED. BY	DATE

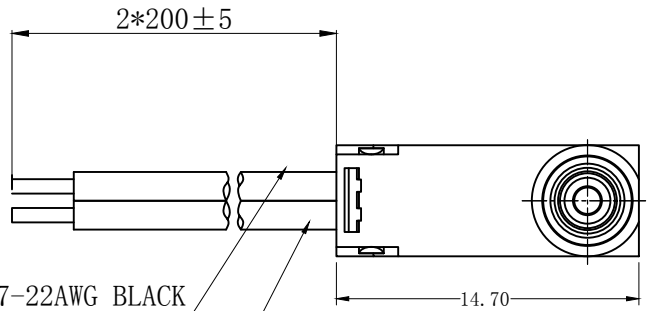

COM: UL1007-22AWG BLACK

NO: UL1007-22AWG BLUE

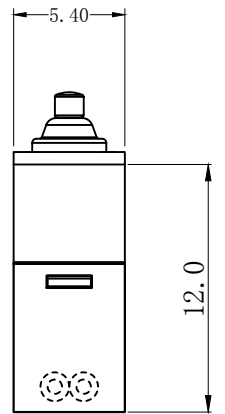
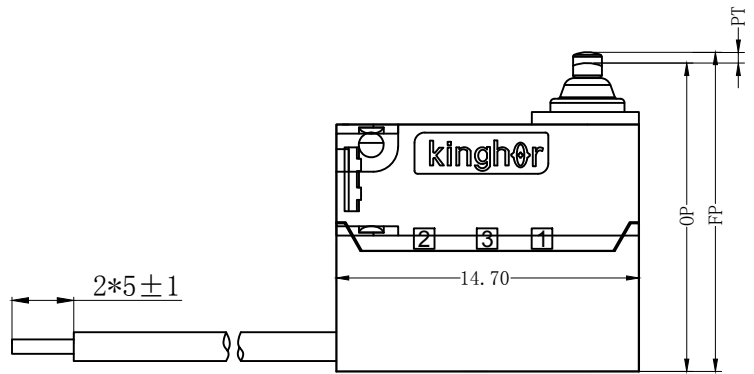

CHARACTERISTICS	
OPERATING FORCE (OF):	130gf Max.
RELEASE FORCE (RF):	13gf Min.
OPERATING POSITION:	3.5 ± 0.2 mm.
PRE TRAVEL:	0.8mm Max.
DIFFERENTIAL TRAVEL:	0.2mm Max.
FREE POSITION:	3.65mm Max.

ELECTRICAL DATA	
RATING	OPERATING LIFE
3A 12VDC	100,000 CYCLES
0.1A 48VDC 125/250VAC	100,000 CYCLES

MECHANICAL LIFE	500,000 CYCLES
GAP TYPE	MICRO
OPERATING TEMP	-25°C ~ +85°C
WATERPROOF	IP67

OUTLINE DRAWING			
TITLE	H3 SERIES MICRO SWITCH		
MODEL	H3-A1		
PART NO.	H3-A1-1B00W2-2-200		
DRAFTED BY	Bing Wang	DATE	2020-6-15
CHECKED BY	Hua Bai	DATE	2020-6-15
APPROVED BY	Hong Chen	DATE	2020-6-15

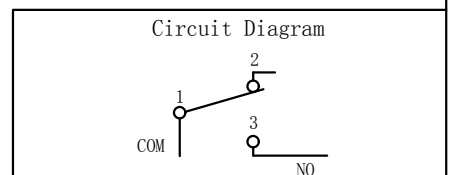

TOLERANCE UNLESS OTHERWISE SPECIFIED							
≤3	1~3	3~10	10~30	30~100	100~200	ANGLE	
±0.2	±0.3	±0.4	±0.6	±1.0	±1.5	±3.0°	

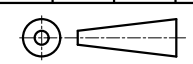

SCALE	
UNIT	mm
VERSION REV	A1

KINGHOR
SWITCHES AND CONTROL EXPERT