

ALUMINUM ELECTROLYTIC CAPACITORS

UUX

Chip Type, Wide Temperature Range

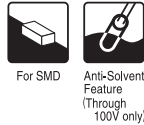

- Chip type, operating over wide temperature range of to -55 to +105°C.
- Designed for surface mounting on high density PC board.
- Applicable to automatic mounting machine fed with carrier tape.
- Compliant to the RoHS directive (2011/65/EU,(EU)2015/863).
- AEC-Q200 compliant. Please contact us for details.

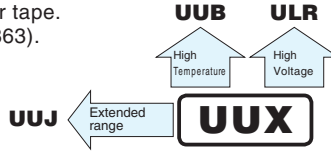

Specifications

Item	Performance Characteristics												
Category Temperature Range	-55 to +105°C (6.3 to 100V), -40 to +105°C (160 to 400V)												
Rated Voltage Range	6.3 to 400V												
Rated Capacitance Range	1 to 1000µF												
Capacitance Tolerance	±20% at 120Hz, 20°C												
Leakage Current	Rated voltage (V)	6.3 to 100										160 to 400	
	Leakage Current	After 1 minute's application of rated voltage at 20°C, leakage current is not more than 0.03CV (µA).										I = 0.04CV+100 (µA) max.(1 minute's at 20°C)	
Tangent of loss angle (tan δ)	Measurement frequency : 120Hz at 20°C												
	Rated voltage (V)	6.3	10	16	25	35	50	63	100	160	200	250	400
Stability at Low Temperature	Measurement frequency: 120Hz												
	Rated voltage (V)	6.3	10	16	25	35	50	63	100	160	200	250	400
	Impedance ratio Z-55°C / Z+20°C	4	4	3	3	3	2	3	4	—	—	—	—
Endurance	The specifications listed at right shall be met when the capacitors are restored to 20°C after the rated voltage is applied for 2000 hours (160 to 400V : 3000hours) at 105°C.												
	Capacitance change	Within ±20% of the initial capacitance value											
Shelf Life	After storing the capacitors under no load at 105°C for 1000 hours and then performing voltage treatment based on JIS C 5101-4 clause 4.1 at 20°C, they shall meet the specified values for the endurance characteristics listed above.												
	Capacitance change	Within ±10% of the initial capacitance value											
Resistance to soldering heat	The capacitors are kept on a hot plate for 30 seconds, which is maintained at 250°C. The capacitors shall meet the characteristic requirements listed at right when they are removed from the plate and restored to 20°C.												
	Capacitance change	Less than or equal to the initial specified value											
Marking	Black print on the case top.												

Chip Type

Type numbering system (Example : 10V 100µF)

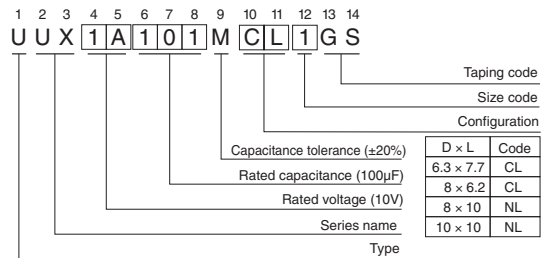
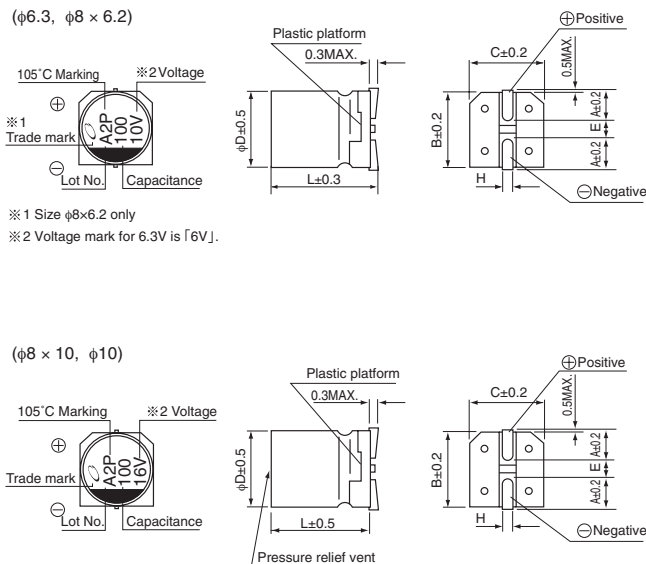

φD × L	6.3 × 7.7	8 × 6.2	8 × 10	10 × 10
A	2.4	3.3	2.9	3.2
B	6.6	8.3	8.3	10.3
C	6.6	8.3	8.3	10.3
E	2.2	2.3	3.1	4.5
L	7.7	6.2	10	10
H	0.5 to 0.8	0.5 to 0.8	0.8 to 1.1	0.8 to 1.1

Frequency coefficient of rated ripple current

Cap.(µF)	Frequency	50 Hz	120 Hz	300 Hz	1 kHz	10 kHz or more
1 to 47		0.80	1.00	1.15	1.40	1.67
100 to 1000		0.85	1.00	1.08	1.20	1.30

● Dimension table in next page.

UUX

■ Dimensions

Rated Voltage (V) (code)	Rated Capacitance (μF)	Case Size φD×L (mm)	tan δ	Leakage Current (μA) (at 20°C after 1 minute)	Rated Ripple (mArms) (105°C/120Hz)	Part Number
6.3 (0J)	220	8×10	0.22	41.58	161	UUX0J221MNL1GS
	220	6.3×7.7	0.22	41.58	121	UUX0J221MCL6GS
	330	8×10	0.22	62.37	288	UUX0J331MNL1GS
	470	10×10	0.22	88.83	340	UUX0J471MNL1GS
	470	8×10	0.22	88.83	316	UUX0J471MNL6GS
	680	10×10	0.22	128.52	408	UUX0J681MNL1GS
	1000	10×10	0.22	189	495	UUX0J102MNL1GS
10 (1A)	100	8×6.2	0.19	30	90	UUX1A101MCL1GS
	220	8×10	0.19	66	173	UUX1A221MNL1GS
	330	10×10	0.19	99	318	UUX1A331MNL1GS
	330	8×10	0.19	99	296	UUX1A331MNL6GS
	470	10×10	0.19	141	351	UUX1A471MNL1GS
	470	8×10	0.19	141	326	UUX1A471MNL6GS
	680	10×10	0.19	204	392	UUX1A681MNL1GS
16 (1C)	100	8×10	0.16	48	148	UUX1C101MNL1GS
	100	6.3×7.7	0.16	48	111	UUX1C101MCL6GS
	220	10×10	0.16	105.6	330	UUX1C221MNL1GS
	220	8×10	0.16	105.6	307	UUX1C221MNL6GS
	330	10×10	0.16	158.4	441	UUX1C331MNL1GS
	330	8×10	0.16	158.4	410	UUX1C331MNL6GS
	470	10×10	0.16	225.6	489	UUX1C471MNL1GS
25 (1E)	47	8×6.2	0.14	35.25	79	UUX1E470MCL1GS
	47	6.3×7.7	0.14	35.25	78	UUX1E470MCL6GS
	100	8×10	0.14	75	181	UUX1E101MNL1GS
	220	10×10	0.14	165	351	UUX1E221MNL1GS
	220	8×10	0.14	165	283	UUX1E221MNL6GS
	330	10×10	0.14	247.5	372	UUX1E331MNL1GS
35 (1V)	33	8×6.2	0.12	34.65	76	UUX1V330MCL1GS
	33	6.3×7.7	0.12	34.65	75	UUX1V330MCL6GS
	47	8×10	0.12	49.35	124	UUX1V470MNL1GS
	100	10×10	0.12	105	304	UUX1V101MNL1GS
	100	8×10	0.12	105	283	UUX1V101MNL6GS
	220	10×10	0.12	231	450	UUX1V221MNL1GS
50 (1H)	22	8×6.2	0.10	33	67	UUX1H220MCL1GS
	22	6.3×7.7	0.10	33	64	UUX1H220MCL6GS
	33	8×10	0.10	49.5	133	UUX1H330MNL1GS
	47	10×10	0.10	70.5	180	UUX1H470MNL1GS
	47	8×10	0.10	70.5	167	UUX1H470MNL6GS
	100	10×10	0.10	150	310	UUX1H101MNL1GS
63 (1J)	10	8×6.2	0.10	18.9	51	UUX1J100MCL1GS
	22	8×10	0.10	41.58	108	UUX1J220MNL1GS
	33	10×10	0.10	62.37	185	UUX1J330MNL1GS
	33	8×10	0.10	62.37	179	UUX1J330MNL6GS
	47	10×10	0.10	88.83	220	UUX1J470MNL1GS
	100	10×10	0.10	189	320	UUX1J101MNL1GS

UUX

■ Dimensions

Rated Voltage (V) (code)	Rated Capacitance (μ F)	Case Size ϕ D \times L (mm)	tan δ	Leakage Current (μ A) (at 20°C after 1 minute)	Rated Ripple (mArms) (105°C/120Hz)	Part Number
100 (2A)	4.7	8 \times 6.2	0.08	14.1	42	UUX2A4R7MCL1GS
	10	8 \times 10	0.08	30	75	UUX2A100MNL1GS
	22	10 \times 10	0.08	66	150	UUX2A220MNL1GS
	22	8 \times 10	0.08	66	121	UUX2A220MNL6GS
	33	10 \times 10	0.08	99	180	UUX2A330MNL1GS
	47	10 \times 10	0.08	141	230	UUX2A470MNL1GS
160 (2C)	10	8 \times 10	0.20	164	57	UUX2C100MNL1GS
	18	10 \times 10	0.20	215.2	64	UUX2C180MNL1GS
200 (2D)	3.3	8 \times 10	0.20	126.4	31	UUX2D3R3MNL1GS
	3.9	8 \times 10	0.20	131.2	34	UUX2D3R9MNL1GS
	4.7	8 \times 10	0.20	137.6	37	UUX2D4R7MNL1GS
	6.8	8 \times 10	0.20	154.4	44	UUX2D6R8MNL1GS
	10	10 \times 10	0.20	180	64	UUX2D100MNL1GS
250 (2E)	3.3	8 \times 10	0.20	133	31	UUX2E3R3MNL1GS
	3.9	8 \times 10	0.20	139	34	UUX2E3R9MNL1GS
	4.7	8 \times 10	0.20	147	37	UUX2E4R7MNL1GS
	6.8	8 \times 10	0.20	168	44	UUX2E6R8MNL1GS
	10	10 \times 10	0.20	200	64	UUX2E100MNL1GS
400 (2G)	1	8 \times 10	0.25	116	25	UUX2G010MNL1GS
	1.8	8 \times 10	0.25	128.8	26	UUX2G1R8MNL1GS
	2.2	8 \times 10	0.25	135.2	27	UUX2G2R2MNL1GS
	3.3	10 \times 10	0.25	152.8	38	UUX2G3R3MNL1GS
	3.9	10 \times 10	0.25	162.4	39	UUX2G3R9MNL1GS
	4.7	10 \times 10	0.25	175.2	40	UUX2G4R7MNL1GS

- Taping specifications are given in page 20.
- Recommended land size, soldering by reflow are given in page 16, 17.
- Please select UUU(p.184) if high C/V products are required.
- Please refer to page 3 for the minimum order quantity.