

LMV321

PRODUCT DESCRIPTION

The LMV321(single)are rail-to-rail input and output voltage feedback amplifier offering low cost. They have a wide input common-mode voltage range and output voltage swing,and take the minimum operating supply voltage down to 2.1V and the maximum recommended supply voltage is 5.5V. temperature range.

The LMV321 provide 1MHz bandwidth at a low current consumption of 60 μ A per amplifier. Very low input bias currents of 10pA enable LMV321 to be used for integrators, photodiode amplifiers, and piezoelectric sensors. Rail-to-rail inputs and outputs are useful to designers buffering ASIC in single-supply systems. Applications for the series amplifiers include safety monitoring, portable equipment, battery and power supply control, and signal conditioning and interfacing for transducers in very low power systems.

APPLICATIONS

- ASIC Input or Output Amplifier
- Sensor Interface
- Piezo Electric Transducer Amplifier
- Medical Instrumentation
- Mobile Communication
- Audio Output
- Portable Systems
- Smoke Detectors
- Notebook PC
- PCMCIA Cards
- Battery –Powered Equipment
- DSP Interface

FEATURES

- Low Cost
- Rail-to-Rail Input and Output 0.8mV Typical VOS
- Unity Gain Stable
- Gain Bandwidth Product: 1MHz
- Very Low Input Bias Currents:
- Operates on 2.1V to 5.5V Supplies
- Input Voltage Range:-0.1V to +5.6V with $V_S = 5.5V$
- Low Supply Current: <60 μ A
- Small Packaging: LMV321 Available in SOT-23-5L.

PIN CONFIGURATIONS

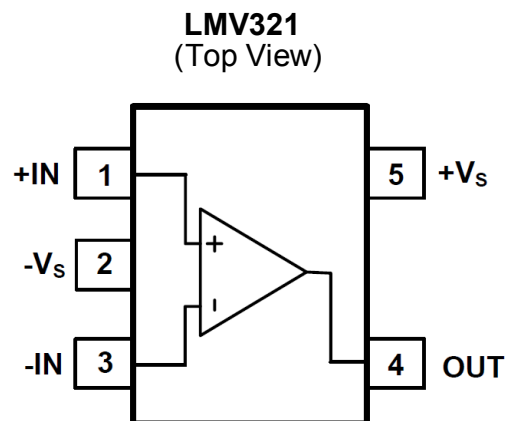

LMV321 ELECTRICAL CHARACTERISTICS

ABSOLUTE MAXIMUM RATINGS

Supply Voltage, V+ to V-.....	7.5V
Common-Mode Input Voltage.....	(-VS) - 0.5V to (+VS) + 0.5V
Storage Temperature Range.....	-65°C to +150°C
Junction Temperature.....	160°C
Operating Temperature Range.....	0°C to +70°C
Lead Temperature Range (Soldering 10 sec).....	260°C

NOTE:

Stresses above those listed under Absolute Maximum Ratings may cause permanent damage to the device. This is a stress rating only; functional operation of the device at these or any other conditions above those indicated in the operational section of this specification is not implied. Exposure to absolute maximum rating conditions for extended periods may affect device reliability.

ELECTRICAL CHARACTERISTICS: $V_s = +5V$

(At $R_L = 100K\Omega$ connected to $V_s/2$, and $V_{OUT} = V_s/2$, unless otherwise noted.)

PARAMETER	CONDITIONS	LMV321				
		TYP	MIN/MAX OVER TEMPERATURE			
		+25°C	+25°C	0°C to 75°C	UNITS	MIN/MAX
INPUT CHARACTERISTICS						
Input Offset Voltage (VOS)		±0.8	±5	±6	mV	MAX
Input Bias Current (IB)		10			pA	TYP
Input Offset Current (IOS)		10			pA	TYP
Common-Mode Voltage Range (VCM)	$V_s = 5.5V$	-0.1 to +5.6			V	TYP
Common-Mode Rejection Ratio (CMRR)	$V_s = 5.5V, V_{CM} = -0.1V$ to 4V	70	62	62	dB	MIN
	$V_s = 5.5V, V_{CM} = -0.1V$ to 5.6V	68	56	55	dB	MIN
Open-Loop Voltage Gain (AOL)	$R_L = 5K\Omega, V_o = 0.1V$ to 4.9V	80	70	70	dB	MIN
	$R_L = 100K\Omega, V_o = 0.035V$ to 4.965V	84	80	80	dB	MIN
OUTPUT CHARACTERISTICS						
Output Voltage Swing from Rail	$R_L = 100K\Omega$	0.008			V	TYP
	$R_L = 10K\Omega$	0.08			V	TYP
Output Current (IOUT)		27	20	18.8	mA	MIN
POWER SUPPLY						
Operating Voltage Range			2.1	2.5	V	MIN
			5.5	5.5	V	MAX
Power Supply Rejection Ratio (PSRR)	$V_s = +2.5V$ to + 5.5V $V_{CM} = (-V_s) + 0.5V$	82	60	58	dB	MIN
Quiescent Current (IQ)	$I_{OUT} = 0$	60	80	86	µA	MAX

LMV321 ELECTRICAL CHARACTERISTICS

PARAMETER	CONDITIONS	LMV321					
		TYP	MIN/MAX OVER TEMPERATURE			UNITS	MIN/ MAX
		+25°C	+25°C	0°C to 75°C			
DYNAMIC PERFORMANCE							
Gain-Bandwidth Product (GBP)	CL = 100pF	1			MHz	TYP	
Slew Rate (SR)	G = +1, 2V Output Step	0.52			V/μs	TYP	
Settling Time to 0.1% (tS)	G = +1, 2V Output Step	5.3			μs	TYP	
Overload Recovery Time	VIN · Gain = VS	2.6			μs	TYP	
NOISE PERFORMANCE							
Voltage Noise Density (en)	f = 1kHz	27			n√Hz	TYP	
	f = 10kHz	20			n√Hz	TYP	

TYPICAL PERFORMANCE CHARACTERISTICS

At TA = +25°C, VS = +5V, and RL = 100KΩ connected to Vs/2, unless otherwise noted.

Small-Signal Step Response

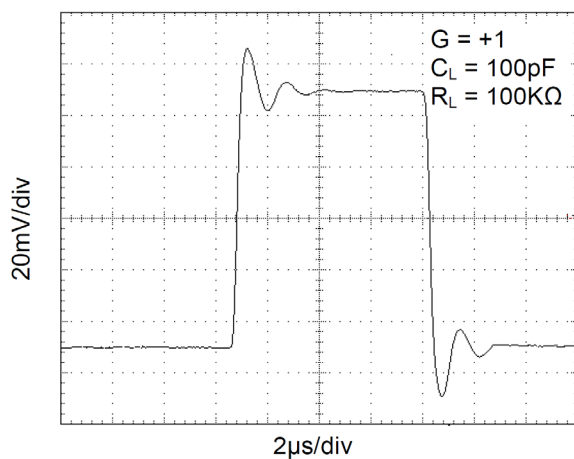

Large-Signal Step Response

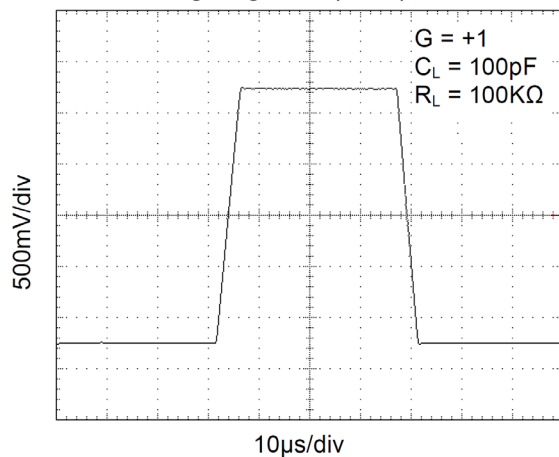

Small-Signal Overshoot vs. Load Capacitance

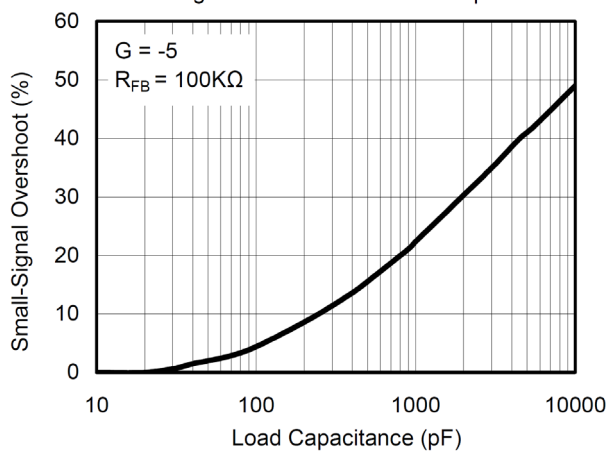

Small-Signal Overshoot vs. Load Capacitance

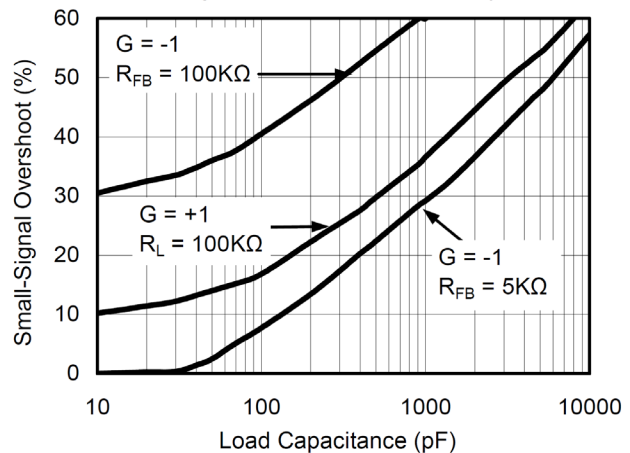

TYPICAL PERFORMANCE CHARACTERISTICS

At TA = +25°C, VS = +5V, and RL = 100KΩ connected to Vs/2, unless otherwise noted.

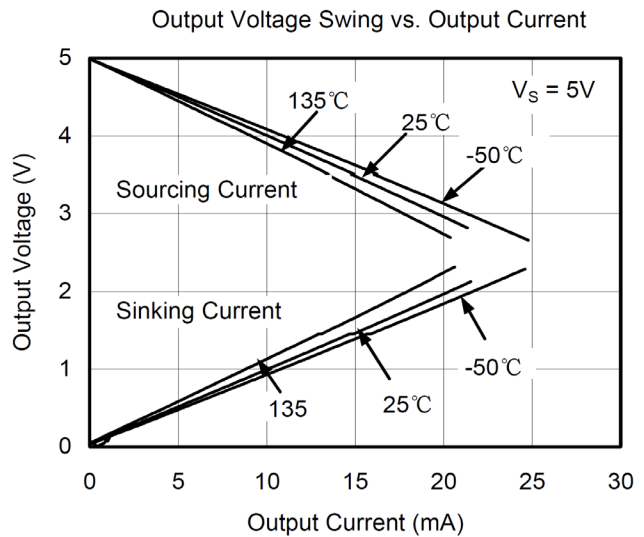
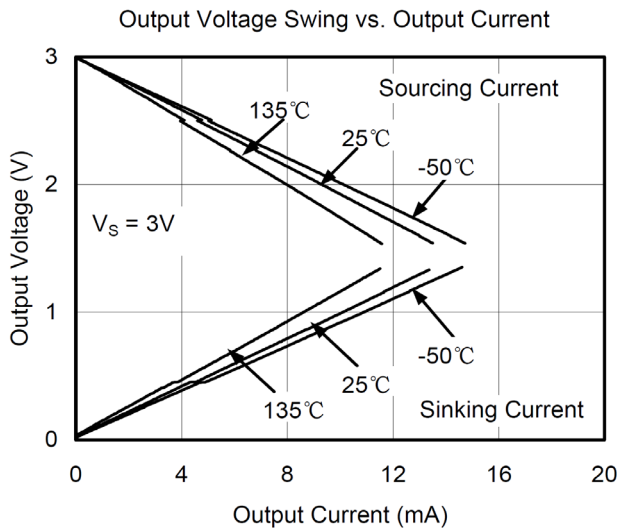
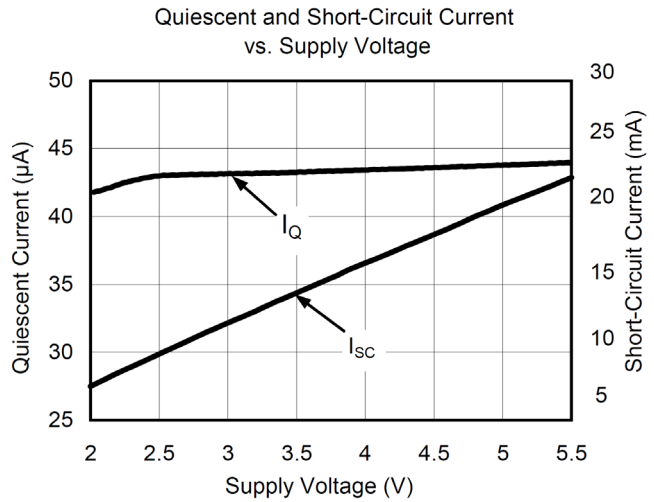
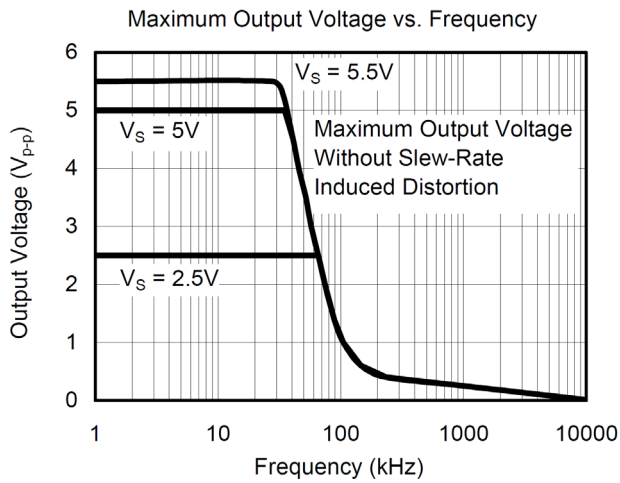

TYPICAL PERFORMANCE CHARACTERISTICS

At TA = +25°C, VS = +5V, and RL = 100KΩ connected to Vs/2, unless otherwise noted.

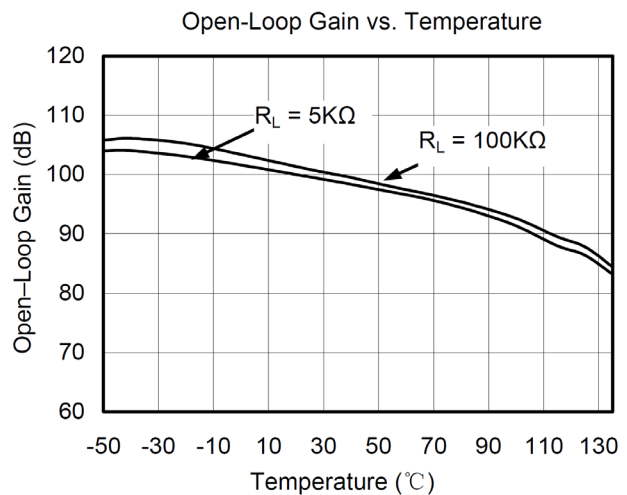
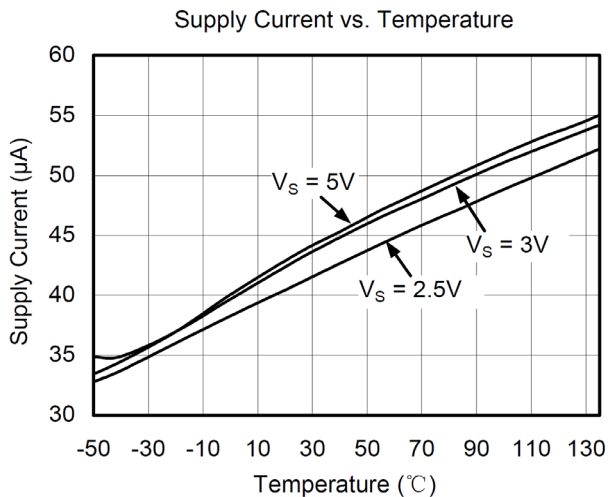

Typical Application

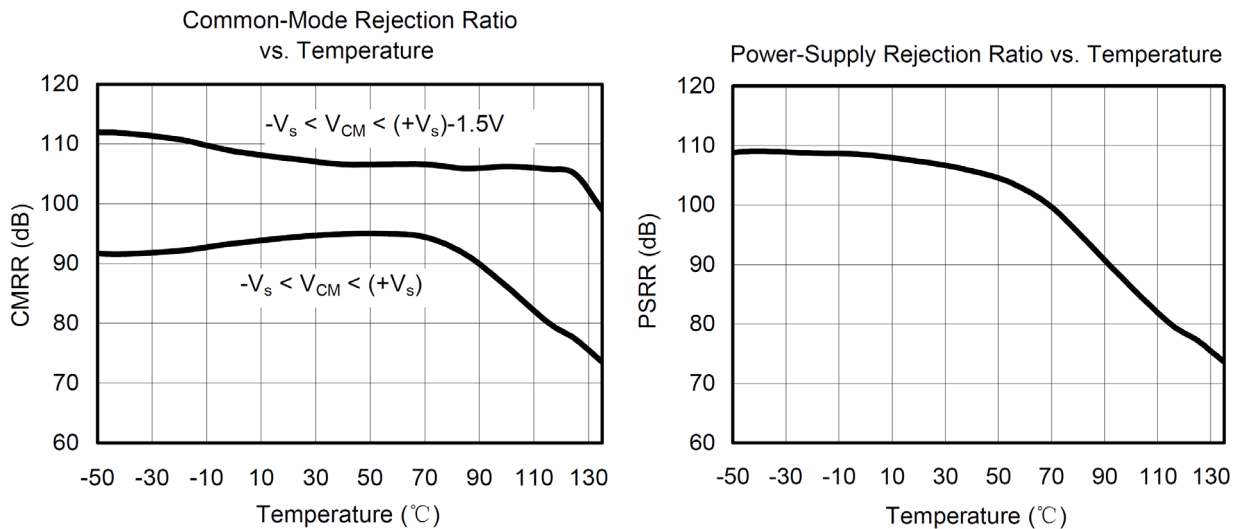

APPLICATION NOTES

Driving Capacitive Loads

The LMV321 can directly drive 250pF in unity-gain without oscillation. The unity-gain follower (buffer) is the most sensitive configuration to capacitive loading. Direct capacitive loading reduces the phase margin of amplifiers and this results in ringing or even oscillation. Applications that require greater capacitive drive capability should use an isolation resistor between the output and the capacitive load like the circuit in Figure 1. This isolation resistor R_{ISO} and the load capacitor C_L form a zero to increase stability. The bigger the R_{ISO} resistor value, the more stable V_{OUT} will be. Note that this method results in a loss of gain accuracy because R_{ISO} forms a voltage divider with the R_{LOAD} .

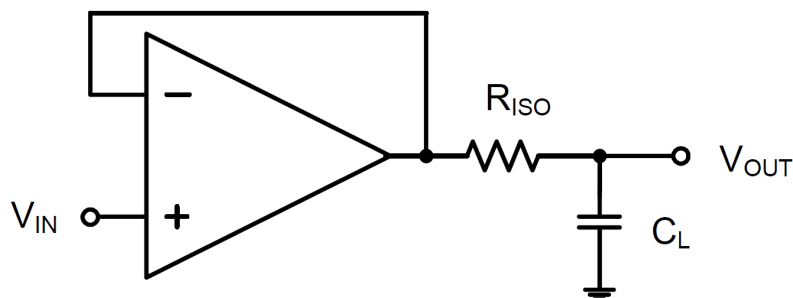

Figure 1. Indirectly Driving Heavy Capacitive Load

An improvement circuit is shown in Figure 2, It provides DC accuracy as well as AC stability. R_F provides the DC accuracy by connecting the inverting signal with the output, C_F and R_{ISO} serve to counteract the loss of phase margin by feeding the high frequency component of the output signal back to the amplifier's inverting input, thereby preserving phase margin in the overall feedback loop.

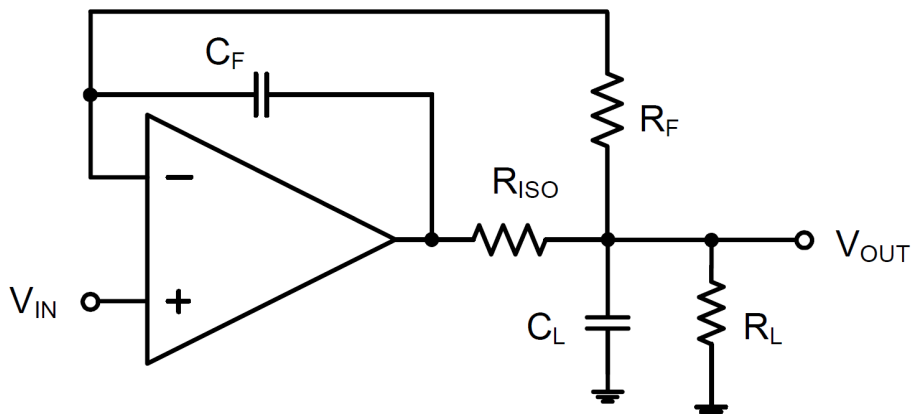

Figure 2. Indirectly Driving Heavy Capacitive Load with DC Accuracy

Typical Application

For no-buffer configuration, there are two other ways to increase the phase margin: (a) by increasing the amplifier's gain or (b) by placing a capacitor in parallel with the feedback resistor to counteract the parasitic capacitance associated with inverting node.

Power-Supply Bypassing and Layout

The LMV321 family operates from either a single +2.5V to +5.5V supply or dual $\pm 1.25\text{V}$ to $\pm 2.75\text{V}$ supplies. For single-supply operation, bypass the power supply VDD with a $0.1\mu\text{F}$ ceramic capacitor which should be placed close to the VDD pin. For dual-supply operation, both the VDD and the VSS supplies should be bypassed to ground with separate $0.1\mu\text{F}$ ceramic capacitors. $2.2\mu\text{F}$ tantalum capacitor can be added for better performance.

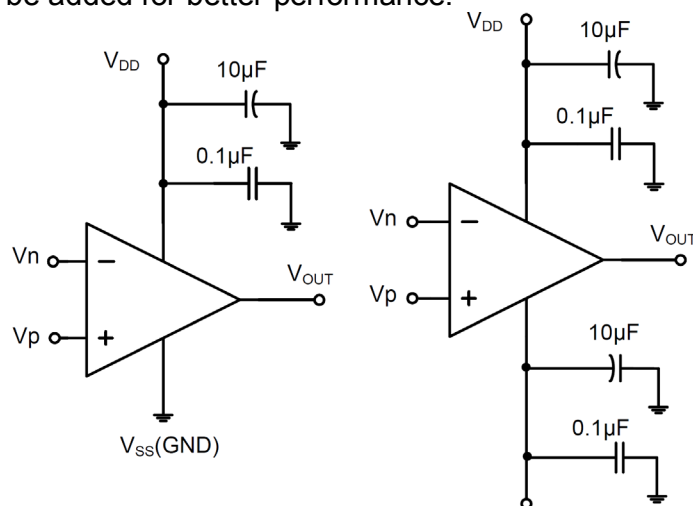

Figure 3. Amplifier with Bypass Capacitors

TYPICAL APPLICATION CIRCUITS

Differential Amplifier

The circuit shown in Figure 4 performs the difference function. If the resistors ratios are equal ($R_4 / R_3 = R_2 / R_1$), then $V_{OUT} = (V_p - V_n) \times R_2 / R_1 + V_{REF}$.

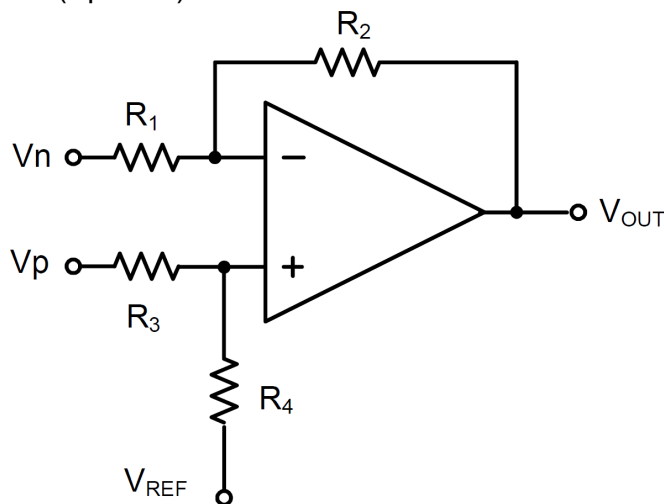

Figure 4. Differential Amplifier

Instrumentation Amplifier

The circuit in Figure 5 performs the same function as that in Figure 4 but with the high input impedance.

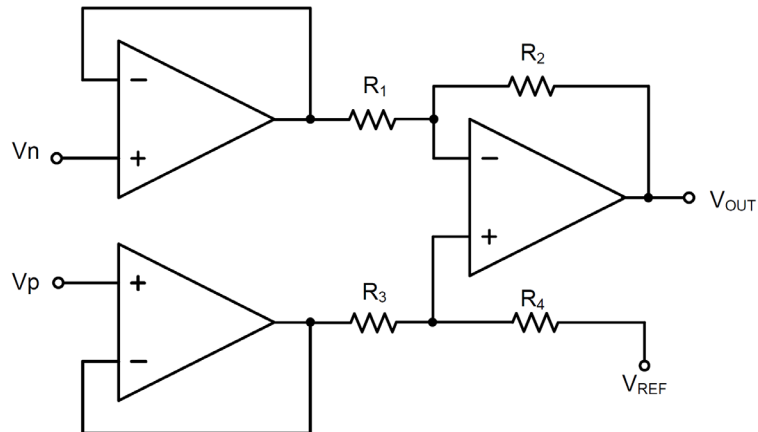

Figure 5. Instrumentation Amplifier

Low Pass Active Filter

The low pass filter shown in Figure 6 has a DC gain of $(-R_2 / R_1)$ and the -3dB corner frequency is $1/2\pi R_2 C$. Make sure the filter is within the bandwidth of the amplifier. The Large values of feedback resistors can couple with parasitic capacitance and cause undesired effects such as ringing or oscillation in high-speed amplifiers. Keep resistors value as low as possible and consistent with output loading consideration.

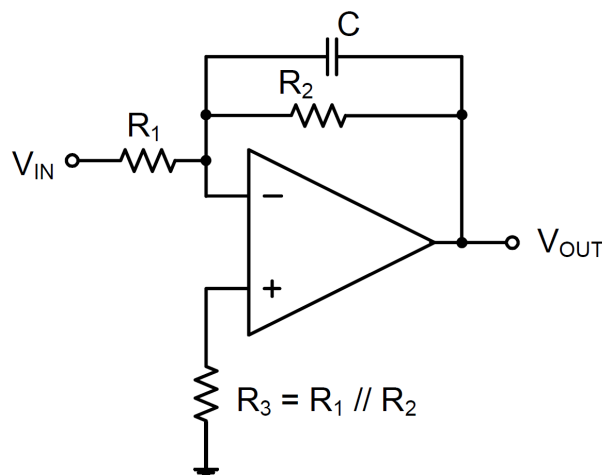
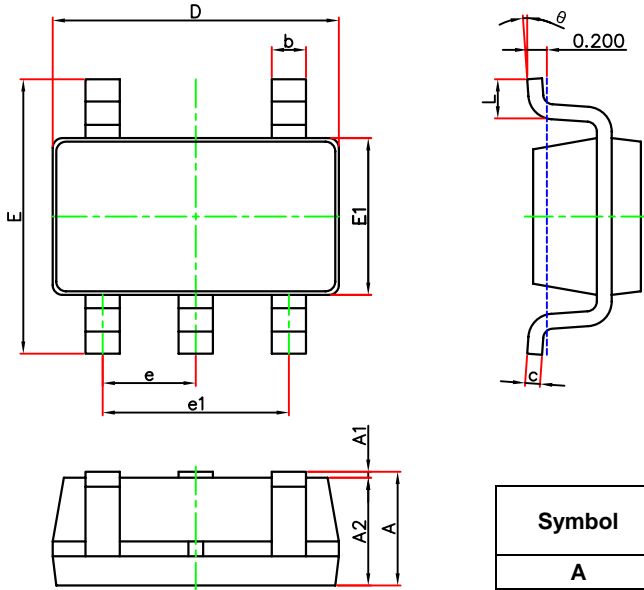

Figure 6. Low Pass Active Filter

SOT-23-5L Package Outline Dimensions



Symbol	Dimensions In Millimeters		Dimensions In Inches	
	Min.	Max.	Min.	Max.
A	1.050	1.250	0.041	0.049
A1	0.000	0.100	0.000	0.004
A2	1.050	1.150	0.041	0.045
b	0.300	0.500	0.012	0.020
c	0.100	0.200	0.004	0.008
D	2.820	3.020	0.111	0.119
E	1.500	1.700	0.059	0.067
E1	2.650	2.950	0.104	0.116
e	0.950(BSC)		0.037(BSC)	
e1	1.800	2.000	0.071	0.079
L	0.300	0.600	0.012	0.024
theta	0°	8°	0°	8°

SOT-23-5L Suggested Pad Layout

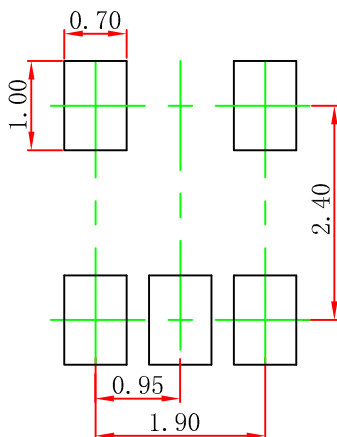

Note:

1. Controlling dimension; in millimeters.
2. General tolerance: $\pm 0.05\text{mm}$.
3. The pad layout is for reference purposes only.

NOTICE

JSCJ reserves the right to make modifications, enhancements, improvements, corrections or other changes without further notice to any product herein. JSCJ does not assume any liability arising out of the application or use of any product described herein.