

Oct.1.2019 Copyright 2019 HIROSE ELECTRIC CO., LTD. All Rights Reserved.  
 In case of consideration for using Automotive equipment / device which demand high reliability, kindly contact our sales window correspondents.

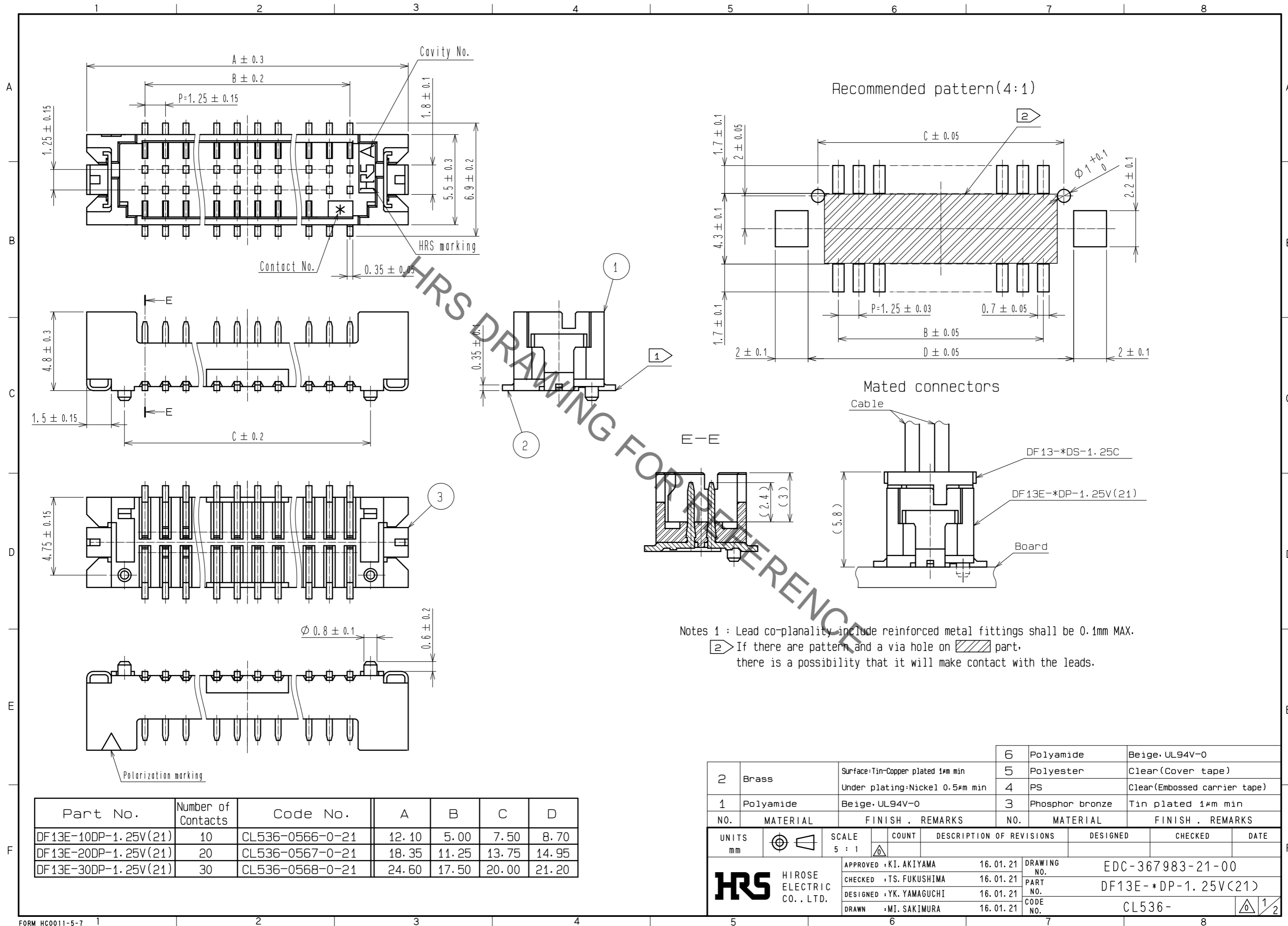

Notes 1 : Lead co-planality include reinforced metal fittings shall be 0.1mm MAX.  
 2 If there are pattern and a via hole on part, there is a possibility that it will make contact with the leads.

Part No.	Number of Contacts	Code No.	A	B	C	D
DF13E-10DP-1.25V(21)	10	CL536-0566-0-21	12.10	5.00	7.50	8.70
DF13E-20DP-1.25V(21)	20	CL536-0567-0-21	18.35	11.25	13.75	14.95
DF13E-30DP-1.25V(21)	30	CL536-0568-0-21	24.60	17.50	20.00	21.20

NO.	MATERIAL	FINISH . REMARKS	NO.	MATERIAL	FINISH . REMARKS
2	Brass	Surface: Tin-Copper plated 1μm min Under plating: Nickel 0.5μm min	6	Polyamide	Beige, UL94V-0
1	Polyamide	Beige, UL94V-0	5	Polyester	Clear (Cover tape)
			4	PS	Clear (Embossed carrier tape)
			3	Phosphor bronze	Tin plated 1μm min

  

UNITS	SCALE	COUNT	DESCRIPTION OF REVISIONS	DESIGNED	CHECKED	DATE
mm	5 : 1	△				

<b>HRS</b> HIROSE ELECTRIC CO., LTD.	APPROVED : KI. AKIYAMA	16.01.21	DRAWING NO.	EDC-367983-21-00
	CHECKED : TS. FUKUSHIMA	16.01.21	PART NO.	DF13E-*DP-1.25V(21)
	DESIGNED : YK. YAMAGUCHI	16.01.21	CODE NO.	CL536-
	DRAWN : MI. SAKIMURA	16.01.21		

Oct.1.2019 Copyright 2019 HIROSE ELECTRIC CO., LTD. All Rights Reserved.  
 In case of consideration for using Automotive equipment / device which demand high reliability, kindly contact our sales window correspondents.

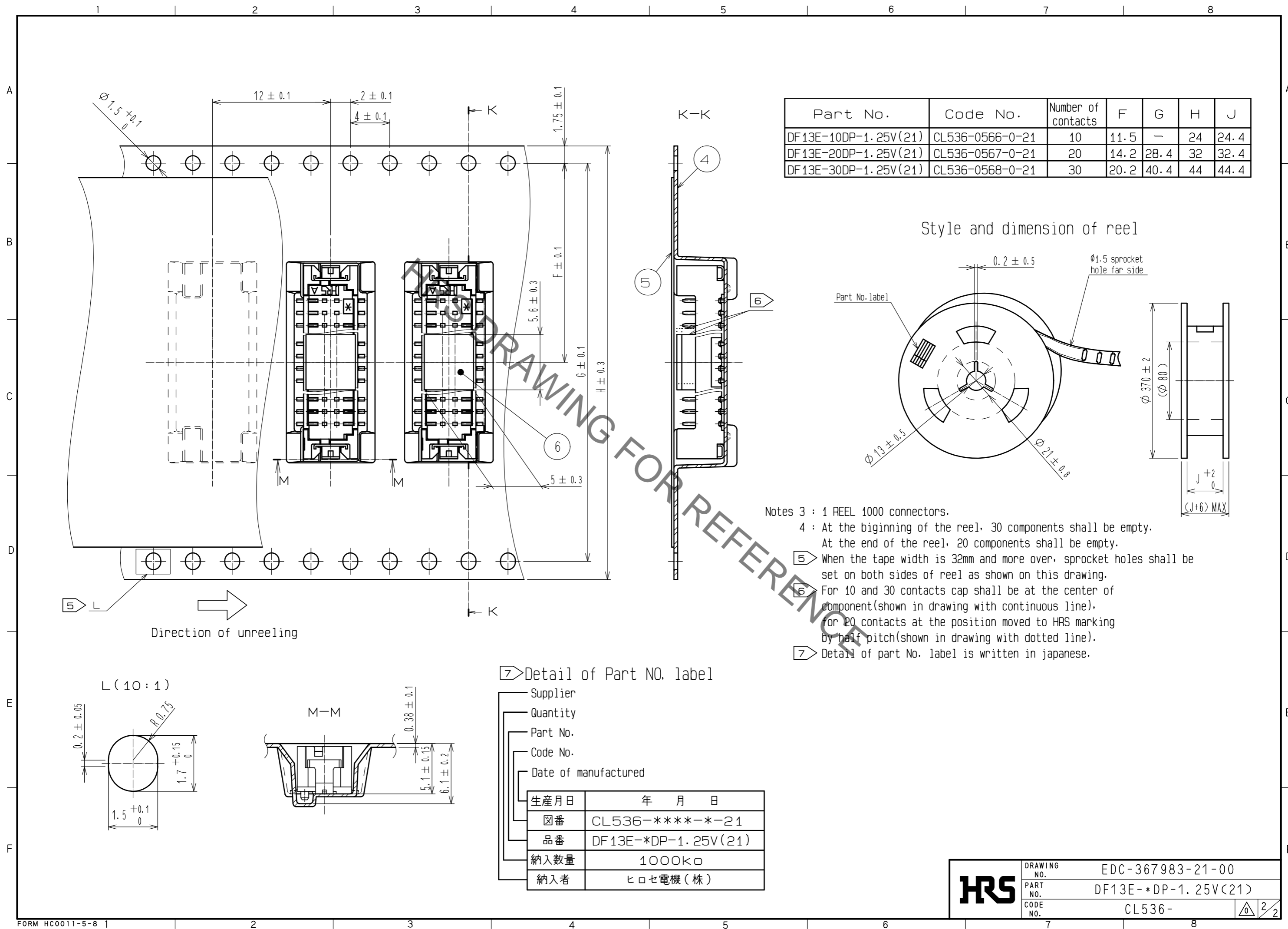

Part No.	Code No.	Number of contacts	F	G	H	J
DF13E-10DP-1.25V(21)	CL536-0566-0-21	10	11.5	-	24	24.4
DF13E-20DP-1.25V(21)	CL536-0567-0-21	20	14.2	28.4	32	32.4
DF13E-30DP-1.25V(21)	CL536-0568-0-21	30	20.2	40.4	44	44.4

Style and dimension of reel

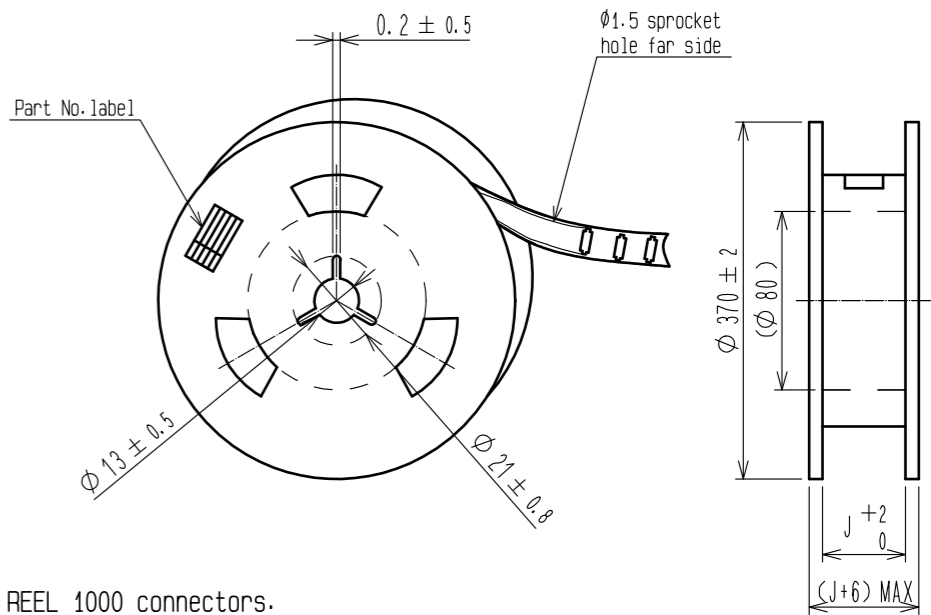

- Notes 3 : 1 REEL 1000 connectors.  
 4 : At the beginning of the reel, 30 components shall be empty.  
 At the end of the reel, 20 components shall be empty.  
 5 : When the tape width is 32mm and more over, sprocket holes shall be set on both sides of reel as shown on this drawing.  
 6 : For 10 and 30 contacts cap shall be at the center of component (shown in drawing with continuous line), for 20 contacts at the position moved to HRS marking by half pitch (shown in drawing with dotted line).  
 7 : Detail of part No. label is written in Japanese.

7 Detail of Part NO. label

Supplier	
Quantity	
Part No.	
Code No.	
Date of manufactured	
生産月日	年 月 日
図番	CL536-****-**-21
品番	DF13E-*DP-1.25V(21)
納入数量	1000K $\square$
納入者	ヒロセ電機(株)

<b>HRS</b>	DRAWING NO.	EDC-367983-21-00
	PART NO.	DF13E-*DP-1.25V(21)
	CODE NO.	CL536-
		$\triangle$ 2/2