

DATA SHEET

SURFACE MOUNT MULTILAYER CERAMIC CAPACITORS

Automotive grade
High Temperature Application

X8G / X8R

16 V TO 100 V

1 nF to 100 nF

RoHS compliant & Halogen Free



SCOPE

This specification describes Automotive grade X8G / X8R series chip capacitors with lead-free terminations and used for automotive equipments.

APPLICATIONS

Decoupling, smoothing, snubber and resonant of high temperature operating equipment.

FEATURES

- AEC-Q200 qualified
- Operating temperature range: -55 to 150°C
- MSL class: MSL I
- AC series soldering is compliant with J-STD-020D
- Halogen free epoxy
- RoHS compliant
- Reduce environmentally hazardous waste
- High component and equipment reliability
- The capacitors are 100% performed by automatic optical inspection prior to taping.

ORDERING INFORMATION - GLOBAL PART NUMBER

All part numbers are identified by the series, size, tolerance, TC material, packing style, voltage, process code, termination and capacitance value.

GLOBAL PART NUMBER

AC XXXX X X XXX X **B** X XXX
 (1) (2) (3) (4) (5) (6) (7)

(1) SIZE – INCH BASED (METRIC)

0805 (2012)

(2) TOLERANCE

- F = ±1%
- G = ±2%
- J = ±5%
- K = ±10%
- M = ±20%

(3) PACKING STYLE

- R = Paper/PE taping reel; Reel 7 inch
- K = Blister taping reel; Reel 7 inch
- P = Paper/PE taping reel; Reel 13 inch
- F = Blister taping reel; Reel 13 inch

(4) TC MATERIAL

- X8G : 0±30 ppm/°C
- X8R : ±15%

(5) RATED VOLTAGE

- 7 = 16 V
- 8 = 25 V
- 9 = 50 V
- 0 = 100 V

(6) PROCESS

- N = Class I MLCC (X8G)
- B = Class II MLCC (X8R)

(7) CAPACITANCE VALUE

2 significant digits+number of zeros
 The 3rd digit signifies the multiplying factor, and letter R is decimal point
 Example: 121 = 12 × 10¹ = 120 pF

CONSTRUCTION

The capacitor consists of a rectangular block of ceramic dielectric in which a number of interleaved metal electrodes are contained. This structure gives rise to a high capacitance per unit volume.

The inner electrodes are connected to the two end terminations and finally covered with a layer of plated tin (Matte Sn). The terminations are lead-free. A cross section of the structure is shown in Fig.1.



Fig. 1 Surface mounted multilayer ceramic capacitor construction

DIMENSION

Table I For outlines see fig. 2

TYPE	L ₁ (mm)	W (mm)	T (MM)	L ₂ / L ₃ (mm)		L ₄ (mm)
				min.	max.	min.
0805	2.0 ±0.10	1.25 ±0.10	0.60 ±0.10			
	2.0 ±0.10	1.25 ±0.10	0.85 ±0.10	0.25	0.75	0.70
	2.0 ±0.20	1.25 ±0.20	1.25 ±0.20			

OUTLINES

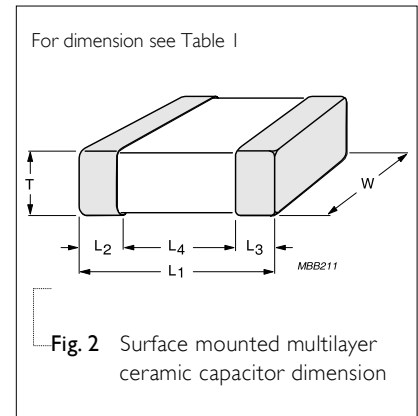

Fig. 2 Surface mounted multilayer ceramic capacitor dimension

CAPACITANCE RANGE & THICKNESS FOR X8G

Table 2-1 Size 0805

CAP.	0805	
	50 V	100 V
1 nF	0.6±0.1	0.6±0.1
2.2 nF	0.6±0.1	0.6±0.1
4.7 nF	0.6±0.1	0.6±0.1
10 nF	0.85±0.1	0.85±0.1

NOTE

1. Values in shaded cells indicate thickness class in mm
2. Capacitance value of non E-6 series is on request

CAPACITANCE RANGE & THICKNESS FOR X8R

Table 2-2 Size 0805

CAP.	0805		
	16 V	25 V	50 V
22 nF	1.25±0.2	1.25±0.2	1.25±0.2
33 nF	1.25±0.2	1.25±0.2	1.25±0.2
47 nF	1.25±0.2	1.25±0.2	1.25±0.2
68 nF	1.25±0.2	1.25±0.2	1.25±0.2
100 nF	1.25±0.2	1.25±0.2	1.25±0.2

NOTE

1. Values in shaded cells indicate thickness class in mm
2. Capacitance value of non E-6 series is on request

THICKNESS CLASSES AND PACKING QUANTITY

Table 3

SIZE CODE	THICKNESS CLASSIFICATION	TAPE WIDTH QUANTITY PER REEL	Ø180 MM / 7 INCH		Ø330 MM / 13 INCH	
			Paper	Blister	Paper	Blister
0805	0.60 ±0.1 mm	8 mm	4,000	---	20,000	---
	0.85 ±0.1 mm	8 mm	4,000	---	15,000	---
	1.25 ±0.2 mm	8 mm	---	3,000	---	10,000

ELECTRICAL CHARACTERISTICS

X8G / X8R DIELECTRIC CAPACITORS; NI/SIN TERMINATIONS

Unless otherwise specified, all test and measurements shall be made under standard atmospheric conditions for testing as given in 5.3 of IEC 60068-1:

- Temperature: 15 °C to 35 °C
- Relative humidity: 25% to 75%
- Air pressure: 86 kPa to 106 kPa

Before the measurements are made, the capacitor shall be stored at the measuring temperature for a time sufficient to allow the entire capacitor to reach this temperature.

The period as prescribed for recovery at the end of a test is normally sufficient for this purpose.

Table 4

DESCRIPTION	VALUE
Capacitance range	1 nF to 100 nF
Capacitance tolerance	
X8G	±1%, ±2%, ±5%
X8R	±5% ⁽¹⁾ , ±10%, ±20%
Dissipation factor (D.F.)	
X8G	0805
50V	1 nF to 10 nF ≤0.1%
100V	1 nF to 10 nF ≤0.1%
X8R	0805
16V	22 nF to 100 nF ≤2.5%
25V	22 nF to 100 nF ≤2.5%
50V	22 nF to 100 nF ≤2.5%
Insulation resistance after 1 minute at U_r (DC)	$IR \geq 10 \text{ G}\Omega$ or $I.R \times C \geq 500$ seconds whichever is less
Maximum capacitance change as a function of temperature (temperature characteristic/coefficient):	
X8G	±30 ppm/°C
X8R	±15%
Operating temperature range:	
X8G / X8R	-55 °C to +150 °C

NOTE

1. Capacitance tolerance ±5% doesn't available for X8R full product range, please contact local sales force before order

SOLDERING RECOMMENDATION

Table 5

SOLDERING METHOD	SIZE 0402	0603	0805	1206	≥ 1210
Reflow	≥ 0.1 μF	≥ 1.0 μF	≥ 2.2 μF	≥ 4.7 μF	Reflow only
Reflow/Wave	< 0.1 μF	< 1.0 μF	< 2.2 μF	< 4.7 μF	---

SOLDERING CONDITIONS

The lead free MLCCs are able to stand the reflow soldering conditions as below:

- Temperature: above 220 °C
- Endurance: 95 to 120 seconds
- Cycles: 3 times

The test of "soldering heat resistance" is carried out in accordance with the schedule of "MIL-STD-202F-method 210F", "The robust construction of chip capacitors allows them to be completely immersed in a solder bath of 270 °C for 10 seconds". Therefore, it is possible to mount MLCCs on one side of a PCB and other discrete components on the reverse (mixed PCBs). Surface Mount Capacitors are tested for solderability at 245 °C during 2 seconds. The test condition for no leaching is 260°C for 30 seconds.

TESTS AND REQUIREMENTS

Table 6 Test procedures and requirements

TEST	TEST METHOD	PROCEDURE	REQUIREMENTS
Mounting	IEC 60384-21/22 4.3	The capacitors may be mounted on printed-circuit boards or ceramic substrates	No visible damage
Capacitance	IEC 60384-21/22 4.5.1	Class 1: At 20 °C, 24 hours after annealing f = 1 MHz for C ≤ 1nF, measuring at voltage V _{rms} at 20 °C f = 1 KHz for C > 1nF, measuring at voltage V _{rms} at 20 °C Class 2: At 20 °C, 24 hours after annealing f = 1 KHz, measuring at voltage V _{rms} at 20 °C	Within specified tolerance
Dissipation Factor (D.F.)	IEC 60384-21/22 4.5.2	Class 1: At 20 °C, 24 hours after annealing f = 1 MHz for C ≤ 1nF, measuring at voltage V _{rms} at 20 °C f = 1 KHz for C > 1nF, measuring at voltage V _{rms} at 20 °C Class 2: At 20 °C, 24 hours after annealing f = 1 KHz, measuring at voltage V _{rms} at 20 °C	In accordance with specification
Insulation Resistance	IEC 60384-21/22 4.5.3	At U _r (DC) for 1 minute	In accordance with specification

TEST	TEST METHOD	PROCEDURE	REQUIREMENTS												
Temperature coefficient	4.6	<p>Capacitance shall be measured by the steps shown in the following table.</p> <p>The capacitance change should be measured after 5 min at each specified temperature stage.</p> <table border="1" style="margin-left: 20px;"> <thead> <tr> <th>Step</th> <th>Temperature(°C)</th> </tr> </thead> <tbody> <tr> <td>a</td> <td>25±2</td> </tr> <tr> <td>b</td> <td>Lower temperature±3°C</td> </tr> <tr> <td>c</td> <td>25±2</td> </tr> <tr> <td>d</td> <td>Upper Temperature±2°C</td> </tr> <tr> <td>e</td> <td>25±2</td> </tr> </tbody> </table> <p>(1) Class I</p> <p>Temperature Coefficient shall be calculated from the formula as below</p> $\text{Temp, Coefficient} = \frac{C2 - C1}{C1 \times \Delta T} \times 10^6 \text{ [ppm/°C]}$ <p>C1: Capacitance at step c C2: Capacitance at 150°C ΔT: 125°C (=150°C -25°C)</p> <p>(2) Class II</p> <p>Capacitance Change shall be calculated from the formula as below</p> $\Delta C = \frac{C2 - C1}{C1} \times 100\%$ <p>C1: Capacitance at step c C2: Capacitance at step b or d</p>	Step	Temperature(°C)	a	25±2	b	Lower temperature±3°C	c	25±2	d	Upper Temperature±2°C	e	25±2	<p>Class I: X8G: ΔC/C: ±30ppm</p> <p>Class2: X8R: ΔC/C: ±15%</p>
Step	Temperature(°C)														
a	25±2														
b	Lower temperature±3°C														
c	25±2														
d	Upper Temperature±2°C														
e	25±2														
High Temperature Exposure	AEC-Q200 3	<p>Unpowered ; 1000hours @ T=150°C</p> <p>Measurement at 24±2 hours after test conclusion.</p>	<p>No visual damage</p> <p>ΔC/C :</p> <p>Class I: X8G: within ±0.5% or 0.5 pF whichever is greater</p> <p>Class2: X8R: ±10%</p> <p>D.F.: within initial specified value</p> <p>IR: within initial specified value</p>												
Temperature Cycling	AEC-Q200 4	<p>Preconditioning: 150 +0/-10 °C for 1 hour, then keep for 24 ±1 hours at room temperature</p> <p>1000 cycles with following detail: 30 minutes at lower category temperature</p>	<p>No visual damage</p> <hr/> <p>ΔC/C</p> <p>Class I: X8G: Within ±1% or 0.5pF, whichever is greater.</p> <p>Class2: X8R: ±10%</p>												

TEST	TEST METHOD	PROCEDURE	REQUIREMENTS
		30 minutes at upper category temperature Recovery time 24 ±2 hours	D.F. meet initial specified value IR meet initial specified value
Destructive Physical Analysis	AEC-Q200 5	10ea X 3 lots. Note: Only applies to SMD ceramics. Electrical test not required.	
Moisture Resistance	AEC-Q200 6	T=24 hrs/per cycle; 10 continuous cycles unpowered. Measurement at 24 ±2 hours after test condition.	No visual damage ΔC/C X8G: Within ±3% or 3 pF, whichever is greater X8R: ±15% D.F. Within initial specified value IR X8G: ≥ 10,000 MΩ X8R: Meet initial specified value

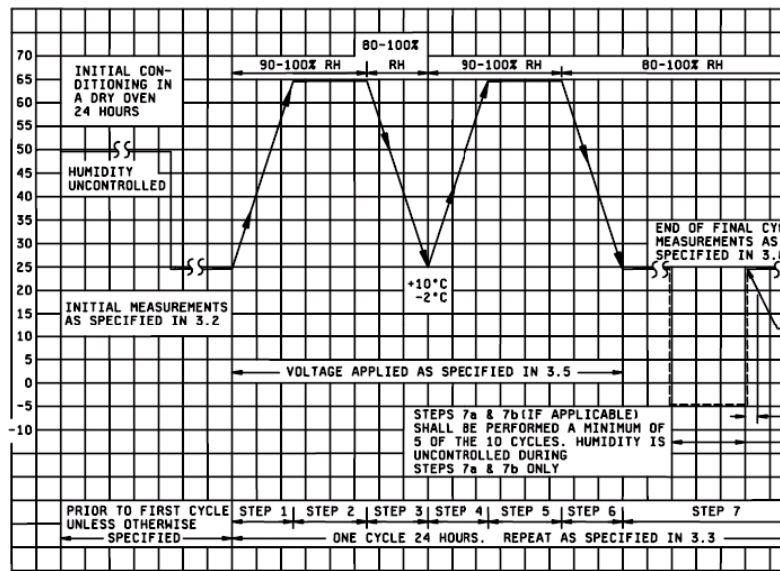

Fig. 3 Moisture resistant

TEST	TEST METHOD	PROCEDURE	REQUIREMENTS
Biased Humidity	AEC-Q200 7	<ol style="list-style-type: none"> Preconditioning, class 2 only: 150 +0/-10 °C /1 hour, then keep for 24 ±1 hour at room temp Initial measure: Parameter: IR Measuring voltage: 1.5V ± 0.1 VDC Note: Series with 100 KΩ & 6.8 KΩ Test condition: 85 °C, 85% R.H. connected with 100 KΩ resistor, applied 1.5V/U_r for 1,000 hours. Recovery: Class1: 6 to 24 hours Class2: 24 ±2 hours Final measure: IR 	<p>No visual damage after recovery</p> <hr/> <p>Class2:</p> <ul style="list-style-type: none"> - Connected to 100 KΩ: C ≤ 25 nF: I.R ≥ 4,000 MΩ or C > 25 nF: (I.R-100 KΩ) × C ≥ 100s. - Connected to 6.8 KΩ: C ≤ 25 nF: I.R ≥ 10,000 MΩ or C > 25 nF: (I.R-6.8 KΩ) × C ≥ 100s. <p>Final measurement: The insulation resistance shall be greater than 0.1 time initial value.</p>
Operational Life	AEC-Q200 8	<ol style="list-style-type: none"> Preconditioning, class 2 only: 150 +0/-10 °C /1 hour, then keep for 24 ±1 hour at room temp Initial measure: Spec: refer to initial spec C, D, IR Endurance test: Temperature: X8R: 150 °C Specified stress voltage applied for 1,000 hours: Applied 2.0 × U_r for ≤ 100V series Applied 1.5 × U_r for 200V, 250V series Applied 1.3 × U_r for 500V, 630V series Applied 1.2 × U_r for 1KV, 2KV, 3KV series Recovery time: 24 ±2 hours Final measure: C, D, IR <p>Note: If the capacitance value is less than the minimum value permitted, then after the other measurements have been made the capacitor shall be preconditioned according to "IEC 60384 4.1" and then the requirement shall be met.</p>	<p>No visual damage</p> <hr/> <p>ΔC/C X8G: Within ±2% or 1 pF, whichever is greater X8R: ±15%</p> <hr/> <p>D.F. X8G: ≤ 0.2% X8R: within initial specified value</p> <p>IR X8G: ≥ 4,000 MΩ or I.R. × Cr ≥ 40Ω.F whichever is less X8R: ≥ 1,000 MΩ or I.R. × Cr ≥ 50Ω.F whichever is less</p>
External Visual	AEC-Q200 9	Any applicable method using × 10 magnification	In accordance with specification
Physical Dimension	AEC-Q200 10	Verify physical dimensions to the applicable device specification.	In accordance with specification

TEST	TEST METHOD	PROCEDURE	REQUIREMENTS
Mechanical Shock	AEC-Q200 13	Three shocks in each direction shall be applied along the three mutually perpendicular axes of the test specimen (18 shocks) Peak value: 1,500 g's Duration: 0.5 ms Velocity change: 15.4 ft/s Waveform: Half-sin	$\Delta C/C$ X8G: Within $\pm 0.5\%$ or 0.5 pF, whichever is greater X8R: $\pm 10\%$ <hr/> D.F. Within initial specified value IR Within initial specified value
Vibration	AEC-Q200 14	5 g's for 20 minutes, 12 cycles each of 3 orientations. Note: Use 8" x 5" PCB, 0.31" thick 7 secure points on one long side and 2 secure points at corners of opposite sides. Parts mounted within 2" from any secure point. Test from 10-2000 Hz.	$\Delta C/C$ X8G: Within $\pm 0.5\%$ or 0.5 pF, whichever is greater X8R: $\pm 10\%$ <hr/> D.F: meet initial specified value IR meet initial specified value
Resistance to Soldering Heat	AEC-Q200 15	Precondition: 150 $\pm 0/-10$ °C for 1 hour, then keep for 24 ± 1 hours at room temperature Preheating: for size ≤ 1206 : 120 °C to 150 °C for 1 minute Preheating: for size > 1206 : 100 °C to 120 °C for 1 minute and 170 °C to 200 °C for 1 minute Solder bath temperature: 260 ± 5 °C Dipping time: 10 ± 0.5 seconds Recovery time: 24 ± 2 hours	Dissolution of the end face plating shall not exceed 25% of the length of the edge concerned <hr/> $\Delta C/C$ X8G: Within $\pm 1\%$ or 0.5 pF, whichever is greater X8R: $\pm 10\%$ <hr/> D.F. within initial specified value IR within initial specified value
Thermal Shock	AEC-Q200 16	1. Preconditioning, class 2 only: 150 $\pm 0/-10$ °C / 1 hour, then keep for 24 ± 1 hour at room temp 2. Initial measure: Spec: refer to initial spec C, D, IR 3. Rapid change of temperature test: X8G / X8R: -55 °C to +150 °C; 300 cycles 15 minutes at lower category temperature; 15 minutes at upper category temperature. 4. Recovery time: Class1: 6 to 24 hours Class2: 24 ± 2 hours 5. Final measure: C, D, IR	No visual damage <hr/> $\Delta C/C$ X8G: Within $\pm 1\%$ or 1 pF, whichever is greater X8R: $\pm 15\%$ <hr/> D.F: meet initial specified value IR meet initial specified value

TEST	TEST METHOD		PROCEDURE	REQUIREMENTS
ESD	AEC-Q200	17	Per AEC-Q200-002	A component passes a voltage level if all components stressed at that voltage level pass.
Solderability	AEC-Q200	18	<p>Preheated to a temperature of 80 °C to 140 °C and maintained for 30 seconds to 60 seconds.</p> <p>Test conditions for lead containing solder alloy</p> <p>Temperature: 235 ±5 °C Dipping time: 2 ±0.2 seconds Depth of immersion: 10 mm Alloy Composition: 60/40 Sn/Pb Number of immersions: 1</p> <p>Test conditions for lead-free containing solder alloy</p> <p>Temperature: 245 ±5 °C Dipping time: 3 ±0.3 seconds Depth of immersion: 10 mm Alloy Composition: SAC305 Number of immersions: 1</p>	The solder should cover over 95% of the critical area of each termination.
Electrical Characterization	AEC-Q200	19	<p>Parametrically test per lot and sample size requirements, summary to show Min, Max, Mean and Standard deviation at room as well as Min and Max operating temperatures.</p> <p>X8G / X8R: -55 °C to +150 °C Normal temperature: 20 °C</p>	<p>ΔC/C</p> <p>X8G: ±30 ppm/°C X8R: ±15%</p>

TEST	TEST METHOD	PROCEDURE	REQUIREMENTS
Board Flex	AEC-Q200 21	<p>Part mounted on a 100 mm X 40 mm FR4 PCB board, which is 1.6 ±0.2 mm thick and has a layer-thickness 35 μm ± 10 μm.</p> <p>Part should be mounted using the following soldering reflow profile.</p> <p>Conditions:</p> <p>Class 1: Bending 3 mm at a rate of 1 mm/s, radius jig 340 mm</p> <p>Class 2: Bending 2 mm at a rate of 1 mm/s, radius jig 340 mm</p>	<p>No visible damage</p> <p>ΔC/C</p> <p>Class 1: X8G: Within ±1% or 0.5 pF, whichever is greater</p> <p>Class 2: X8R: ±10%</p>

Test Substrate:

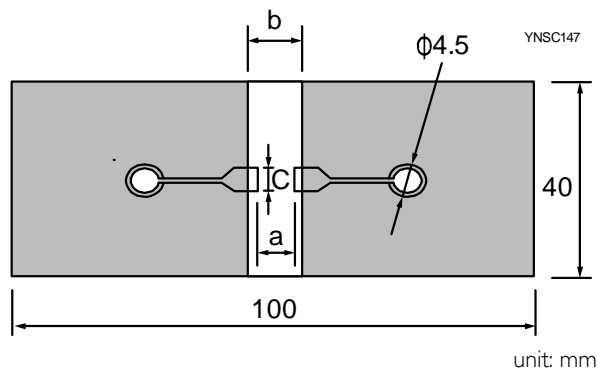

Type	Dimension(mm)		
	a	b	c
0201	0.3	0.9	0.3
0402	0.4	1.5	0.5
0603	1.0	3.0	1.2
0805	1.2	4.0	1.65
1206	2.2	5.0	1.65
1210	2.2	5.0	2.0
1808	3.5	7.0	3.7

Terminal Strength	AEC-Q200 22	<p>With the component mounted on a PCB obtained with the device to be tested, apply a 17.7N (1.8Kg) force to the side of a device being tested.</p> <p>This force shall be applied for 60+1 seconds.</p> <p>Also the force shall be applied gradually as not to apply a shock to the component being tested.</p> <p>* Apply 2N force for 0402 size.</p>	<p>Magnification of 20X or greater may be employed for inspection of the mechanical integrity of the device body, terminals and body/terminal junction.</p> <p>Before, during and after the test, the device shall comply with all electrical requirements stated in this specification.</p>
Beam Load Test	AEC-Q200 23	<p>Place the part in the beam load fixture. Apply a force until the part breaks or the minimum acceptable level required in the user specification(s) is attained.</p>	<p>≤ 0805 Thickness > 0.5mm: 20N Thickness ≤ 0.5mm: 8N</p> <p>≥ 1206 Thickness ≥ 1.25 mm: 54N Thickness < 1.25 mm: 15N</p>

TEST	TEST METHOD	PROCEDURE	REQUIREMENTS
Voltage Proof		1. Specified stress voltage applied for 1~5 seconds 2. $U_r \leq 100\text{ V}$: series applied $2.5 U_r$ 3. $100\text{ V} < U_r \leq 200\text{ V}$ series applied $(1.5 U_r + 100)$ 4. $200\text{ V} < U_r \leq 500\text{ V}$ series applied $(1.3 U_r + 100)$ 5. $U_r > 500\text{ V}$: $1.3 U_r$ 6. $U_r \geq 1000\text{ V}$: $1.2 U_r$ Charge/Discharge current is less than 50 mA	No breakdown or flashover

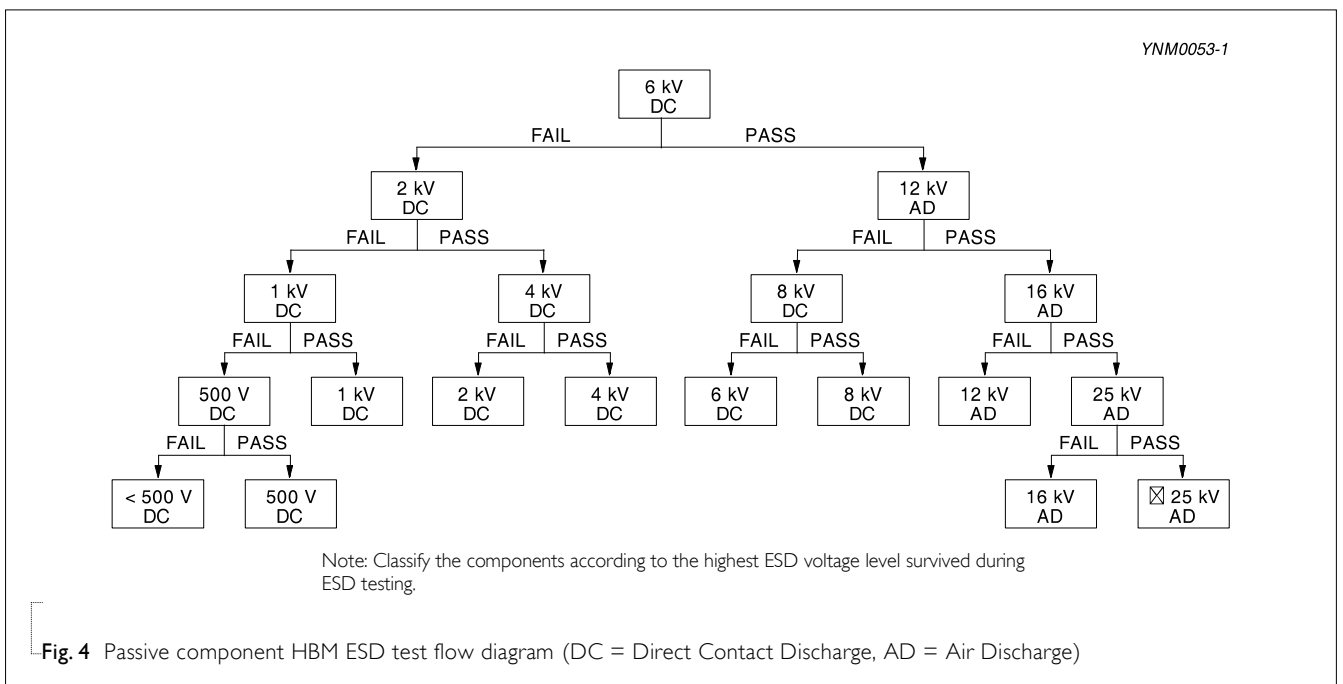

REVISION HISTORY

REVISION	DATE	CHANGE NOTIFICATION	DESCRIPTION
Version 1	Oct, 2, 2019	-	- Add X8G product range, 0805, 1nF to 10nF, 50V to 100V
Version 0	Dec. 12, 2018	-	- New

LEGAL DISCLAIMER

Yageo, its distributors and agents (collectively, “Yageo”), hereby disclaims any and all liabilities for any errors, inaccuracies or incompleteness contained in any product related information, including but not limited to product specifications, datasheets, pictures and/or graphics. Yageo may make changes, modifications and/or improvements to product related information at any time and without notice.

Yageo makes no representation, warranty, and/or guarantee about the fitness of its products for any particular purpose or the continuing production of any of its products. To the maximum extent permitted by law, Yageo disclaims (i) any and all liability arising out of the application or use of any Yageo product, (ii) any and all liability, including without limitation special, consequential or incidental damages, and (iii) any and all implied warranties, including warranties of fitness for a particular purpose, non-infringement and merchantability.

Yageo statements regarding the suitability of products for certain types of applications are based on Yageo’s knowledge of typical operating conditions for such types of applications in a generic nature. Such statements are neither binding statements of Yageo nor intended to constitute any warranty concerning the suitability for a specific customer application or use. They are intended for use only by customers with requisite knowledge and experience for determining whether Yageo products are the correct products for their application or use. In addition, unpredictable and isolated cases of product failure may still occur, therefore, customer application or use of Yageo products which requires higher degree of reliability or safety, shall employ additional protective safeguard measures to ensure that product failure would not result in personal injury or property damage.

Yageo products are not designed for application or use in medical, life-saving, or life-sustaining devices or for any other application or use in which the failure of Yageo products could result in personal injury or death. Customers using or selling Yageo products not expressly indicated for above-mentioned purposes shall do so at their own risk and agree to fully indemnify Yageo and hold Yageo harmless.

Information provided here is intended to indicate product specifications only. Yageo reserves all the rights for revising this content without further notification, as long as products are unchanged. Any product change will be announced by PCN.