

## Features

- High Performance, Low Power 32-Bit Atmel® AVR® Microcontroller
  - Compact Single-cycle RISC Instruction Set Including DSP Instruction Set
  - Read-Modify-Write Instructions and Atomic Bit Manipulation
  - Performing up to 1.39 DMIPS / MHz
    - Up to 83 DMIPS Running at 60 MHz from Flash
    - Up to 46 DMIPS Running at 30 MHz from Flash
  - Memory Protection Unit
- Multi-hierarchy Bus System
  - High-Performance Data Transfers on Separate Buses for Increased Performance
  - 7 Peripheral DMA Channels Improves Speed for Peripheral Communication
- Internal High-Speed Flash
  - 512K Bytes, 256K Bytes, 128K Bytes, 64K Bytes Versions
  - Single Cycle Access up to 30 MHz
  - Prefetch Buffer Optimizing Instruction Execution at Maximum Speed
  - 4ms Page Programming Time and 8ms Full-Chip Erase Time
  - 100,000 Write Cycles, 15-year Data Retention Capability
  - Flash Security Locks and User Defined Configuration Area
- Internal High-Speed SRAM, Single-Cycle Access at Full Speed
  - 96K Bytes (512KB Flash), 32K Bytes (256KB and 128KB Flash), 16K Bytes (64KB Flash)
- Interrupt Controller
  - Autovectored Low Latency Interrupt Service with Programmable Priority
- System Functions
  - Power and Clock Manager Including Internal RC Clock and One 32KHz Oscillator
  - Two Multipurpose Oscillators and Two Phase-Lock-Loop (PLL) allowing Independent CPU Frequency from USB Frequency
  - Watchdog Timer, Real-Time Clock Timer
- Universal Serial Bus (USB)
  - Device 2.0 and Embedded Host Low Speed and Full Speed
  - Flexible End-Point Configuration and Management with Dedicated DMA Channels
  - On-chip Transceivers Including Pull-Ups
  - USB Wake Up from Sleep Functionality
- One Three-Channel 16-bit Timer/Counter (TC)
  - Three External Clock Inputs, PWM, Capture and Various Counting Capabilities
- One 7-Channel 20-bit Pulse Width Modulation Controller (PWM)
- Three Universal Synchronous/Asynchronous Receiver/Transmitters (USART)
  - Independent Baudrate Generator, Support for SPI, IrDA and ISO7816 interfaces
  - Support for Hardware Handshaking, RS485 Interfaces and Modem Line
- One Master/Slave Serial Peripheral Interfaces (SPI) with Chip Select Signals
- One Synchronous Serial Protocol Controller
  - Supports I<sup>2</sup>S and Generic Frame-Based Protocols
- One Master/Slave Two-Wire Interface (TWI), 400kbit/s I<sup>2</sup>C-compatible
- One 8-channel 10-bit Analog-To-Digital Converter, 384ks/s
- 16-bit Stereo Audio Bitstream DAC
  - Sample Rate Up to 50 KHz
- QTouch® Library Support
  - Capacitive Touch Buttons, Sliders, and Wheels
  - QTouch and QMatrix Acquisition



## 32-bit ATMEL AVR Microcontroller

**AT32UC3B0512**  
**AT32UC3B0256**  
**AT32UC3B0128**  
**AT32UC3B064**  
**AT32UC3B1512**  
**AT32UC3B1256**  
**AT32UC3B1128**  
**AT32UC3B164**

## Summary



- **On-Chip Debug System (JTAG interface)**
  - **Nexus Class 2+, Runtime Control, Non-Intrusive Data and Program Trace**
- **64-pin TQFP/QFN (44 GPIO pins), 48-pin TQFP/QFN (28 GPIO pins)**
- **5V Input Tolerant I/Os, including 4 high-drive pins**
- **Single 3.3V Power Supply or Dual 1.8V-3.3V Power Supply**

## 1. Description

The AT32UC3B is a complete System-On-Chip microcontroller based on the AVR32 UC RISC processor running at frequencies up to 60 MHz. AVR32 UC is a high-performance 32-bit RISC microprocessor core, designed for cost-sensitive embedded applications, with particular emphasis on low power consumption, high code density and high performance.

The processor implements a Memory Protection Unit (MPU) and a fast and flexible interrupt controller for supporting modern operating systems and real-time operating systems.

Higher computation capability is achieved using a rich set of DSP instructions.

The AT32UC3B incorporates on-chip Flash and SRAM memories for secure and fast access.

The Peripheral Direct Memory Access controller enables data transfers between peripherals and memories without processor involvement. PDCA drastically reduces processing overhead when transferring continuous and large data streams between modules within the MCU.

The Power Manager improves design flexibility and security: the on-chip Brown-Out Detector monitors the power supply, the CPU runs from the on-chip RC oscillator or from one of external oscillator sources, a Real-Time Clock and its associated timer keeps track of the time.

The Timer/Counter includes three identical 16-bit timer/counter channels. Each channel can be independently programmed to perform frequency measurement, event counting, interval measurement, pulse generation, delay timing and pulse width modulation.

The PWM modules provides seven independent channels with many configuration options including polarity, edge alignment and waveform non overlap control. One PWM channel can trigger ADC conversions for more accurate close loop control implementations.

The AT32UC3B also features many communication interfaces for communication intensive applications. In addition to standard serial interfaces like USART, SPI or TWI, other interfaces like flexible Synchronous Serial Controller and USB are available. The USART supports different communication modes, like SPI mode.

The Synchronous Serial Controller provides easy access to serial communication protocols and audio standards like I<sup>2</sup>S, UART or SPI.

The Full-Speed USB 2.0 Device interface supports several USB Classes at the same time thanks to the rich End-Point configuration. The Embedded Host interface allows device like a USB Flash disk or a USB printer to be directly connected to the processor.

Atmel offers the QTouch library for embedding capacitive touch buttons, sliders, and wheels functionality into AVR microcontrollers. The patented charge-transfer signal acquisition offers robust sensing and included fully debounced reporting of touch keys and includes Adjacent Key Suppression<sup>®</sup> (AKS<sup>®</sup>) technology for unambiguous detection of key events. The easy-to-use QTouch Suite toolchain allows you to explore, develop, and debug your own touch applications.

AT32UC3B integrates a class 2+ Nexus 2.0 On-Chip Debug (OCD) System, with non-intrusive real-time trace, full-speed read/write memory access in addition to basic runtime control. The Nanotrace interface enables trace feature for JTAG-based debuggers.

## 2. Overview

### 2.1 Blockdiagram

Figure 2-1. Block diagram

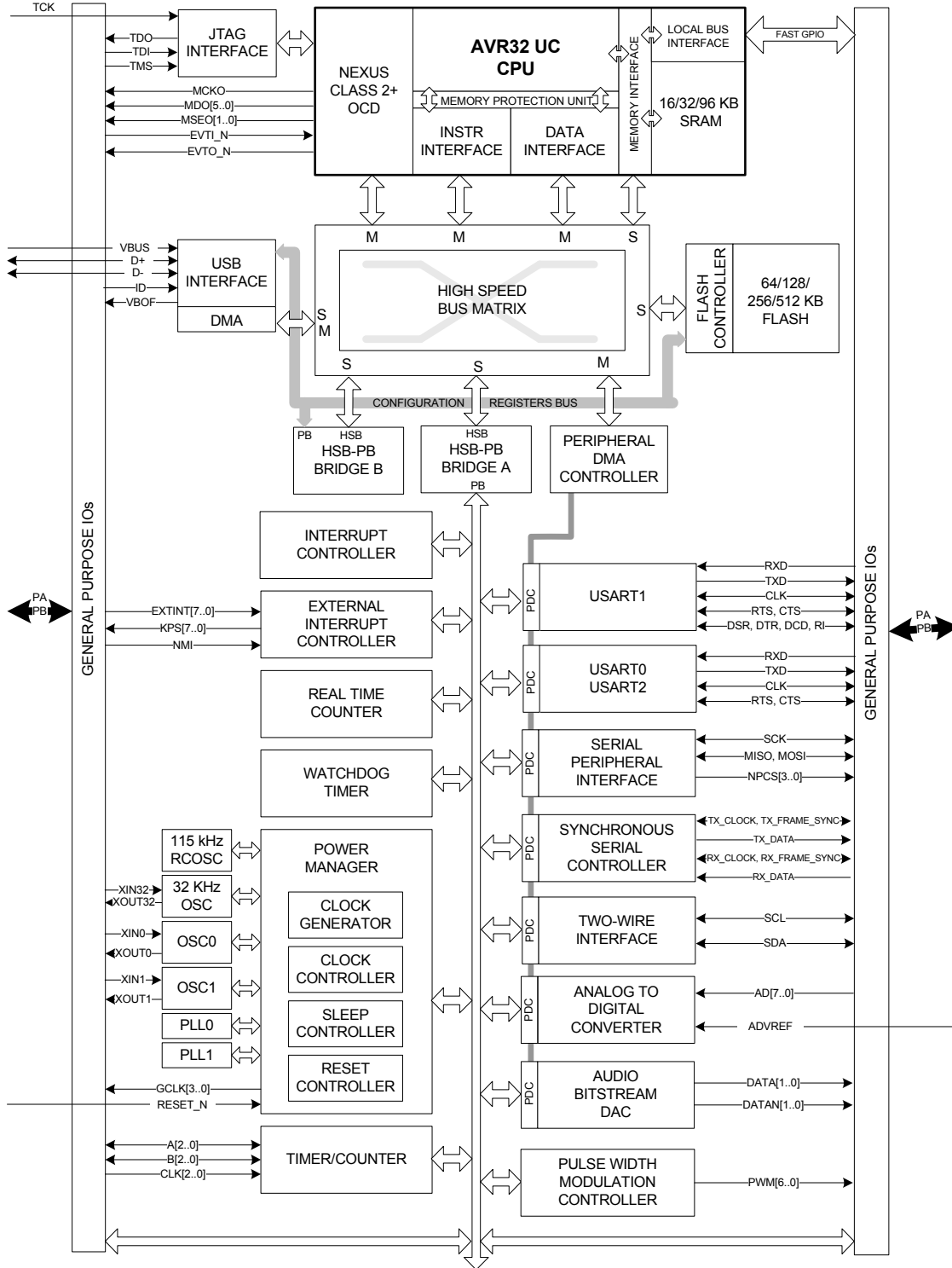

## 3. Configuration Summary

The table below lists all AT32UC3B memory and package configurations:

**Table 3-1.** Configuration Summary

Feature	AT32UC3B0512	AT32UC3B0256/128/64	AT32UC3B1512	AT32UC3B1256/128/64
Flash	512 KB	256/128/64 KB	512 KB	256/128/64 KB
SRAM	96KB	32/32/16KB	96KB	32/16/16KB
GPIO	44		28	
External Interrupts	8		6	
TWI			1	
USART			3	
Peripheral DMA Channels			7	
SPI			1	
Full Speed USB	Mini-Host + Device		Device	
SSC	1		0	
Audio Bitstream DAC	1	0	1	0
Timer/Counter Channels			3	
PWM Channels			7	
Watchdog Timer			1	
Real-Time Clock Timer			1	
Power Manager			1	
Oscillators	PLL 80-240 MHz (PLL0/PLL1) Crystal Oscillators 0.4-20 MHz (OSC0) Crystal Oscillator 32 KHz (OSC32K) RC Oscillator 115 kHz (RCSYS)			
	Crystal Oscillators 0.4-20 MHz (OSC1)			
10-bit ADC number of channels	8		6	
JTAG			1	
Max Frequency			60 MHz	
Package	TQFP64, QFN64		TQFP48, QFN48	

## 4. Package and Pinout

### 4.1 Package

The device pins are multiplexed with peripheral functions as described in the Peripheral Multiplexing on I/O Line section.

Figure 4-1. TQFP64 / QFN64 Pinout

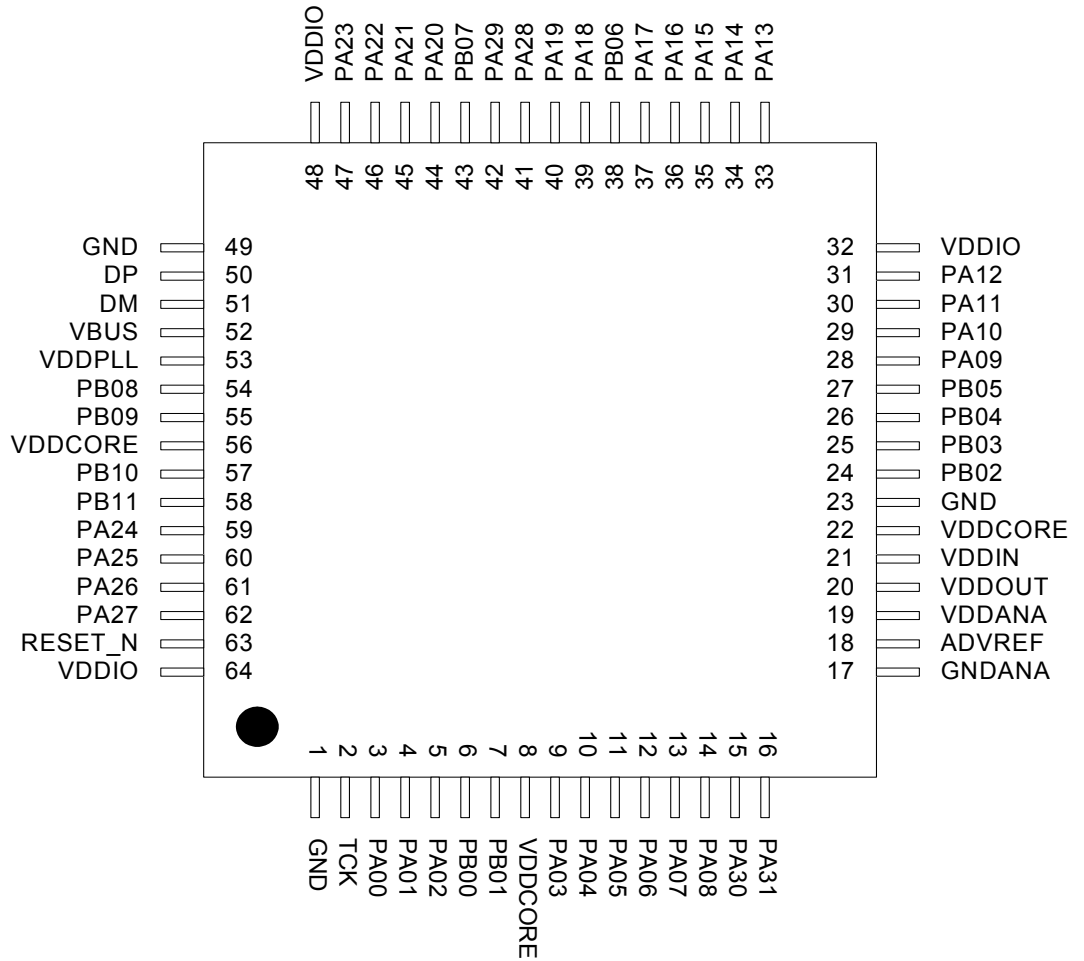

**Figure 4-2.** TQFP48 / QFN48 Pinout

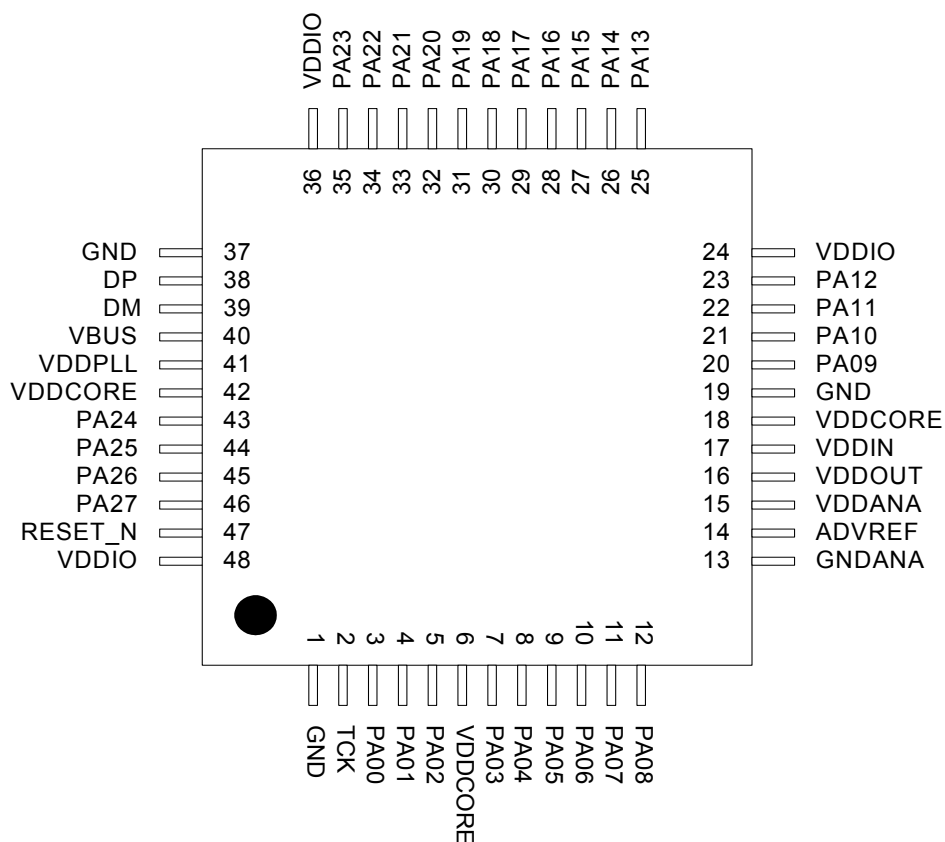

Note: The exposed pad is not connected to anything internally, but should be soldered to ground to increase board level reliability.

## 4.2 Peripheral Multiplexing on I/O lines

### 4.2.1 Multiplexed signals

Each GPIO line can be assigned to one of 4 peripheral functions; A, B, C or D (D is only available for UC3Bx512 parts). The following table define how the I/O lines on the peripherals A, B, C or D are multiplexed by the GPIO.

**Table 4-1.** GPIO Controller Function Multiplexing

48-pin	64-pin	PIN	GPIO Pin	Function A	Function B	Function C	Function D (only for UC3Bx512)
3	3	PA00	GPIO 0				
4	4	PA01	GPIO 1				
5	5	PA02	GPIO 2				
7	9	PA03	GPIO 3	ADC - AD[0]	PM - GCLK[0]	USBB - USB_ID	ABDAC - DATA[0]
8	10	PA04	GPIO 4	ADC - AD[1]	PM - GCLK[1]	USBB - USB_VBOF	ABDAC - DATAN[0]
9	11	PA05	GPIO 5	EIC - EXTINT[0]	ADC - AD[2]	USART1 - DCD	ABDAC - DATA[1]

**Table 4-1. GPIO Controller Function Multiplexing**

10	12	PA06	GPIO 6	EIC - EXTINT[1]	ADC - AD[3]	USART1 - DSR	ABDAC - DATAN[1]
11	13	PA07	GPIO 7	PWM - PWM[0]	ADC - AD[4]	USART1 - DTR	SSC - RX_FRAME_SYNC
12	14	PA08	GPIO 8	PWM - PWM[1]	ADC - AD[5]	USART1 - RI	SSC - RX_CLOCK
20	28	PA09	GPIO 9	TWI - SCL	SPI0 - NPCS[2]	USART1 - CTS	
21	29	PA10	GPIO 10	TWI - SDA	SPI0 - NPCS[3]	USART1 - RTS	
22	30	PA11	GPIO 11	USART0 - RTS	TC - A2	PWM - PWM[0]	SSC - RX_DATA
23	31	PA12	GPIO 12	USART0 - CTS	TC - B2	PWM - PWM[1]	USART1 - TXD
25	33	PA13	GPIO 13	EIC - NMI	PWM - PWM[2]	USART0 - CLK	SSC - RX_CLOCK
26	34	PA14	GPIO 14	SPI0 - MOSI	PWM - PWM[3]	EIC - EXTINT[2]	PM - GCLK[2]
27	35	PA15	GPIO 15	SPI0 - SCK	PWM - PWM[4]	USART2 - CLK	
28	36	PA16	GPIO 16	SPI0 - NPCS[0]	TC - CLK1	PWM - PWM[4]	
29	37	PA17	GPIO 17	SPI0 - NPCS[1]	TC - CLK2	SPI0 - SCK	USART1 - RXD
30	39	PA18	GPIO 18	USART0 - RXD	PWM - PWM[5]	SPI0 - MISO	SSC - RX_FRAME_SYNC
31	40	PA19	GPIO 19	USART0 - TXD	PWM - PWM[6]	SPI0 - MOSI	SSC - TX_CLOCK
32	44	PA20	GPIO 20	USART1 - CLK	TC - CLK0	USART2 - RXD	SSC - TX_DATA
33	45	PA21	GPIO 21	PWM - PWM[2]	TC - A1	USART2 - TXD	SSC - TX_FRAME_SYNC
34	46	PA22	GPIO 22	PWM - PWM[6]	TC - B1	ADC - TRIGGER	ABDAC - DATA[0]
35	47	PA23	GPIO 23	USART1 - TXD	SPI0 - NPCS[1]	EIC - EXTINT[3]	PWM - PWM[0]
43	59	PA24	GPIO 24	USART1 - RXD	SPI0 - NPCS[0]	EIC - EXTINT[4]	PWM - PWM[1]
44	60	PA25	GPIO 25	SPI0 - MISO	PWM - PWM[3]	EIC - EXTINT[5]	
45	61	PA26	GPIO 26	USBB - USB_ID	USART2 - TXD	TC - A0	ABDAC - DATA[1]
46	62	PA27	GPIO 27	USBB - USB_VBOF	USART2 - RXD	TC - B0	ABDAC - DATAN[1]
	41	PA28	GPIO 28	USART0 - CLK	PWM - PWM[4]	SPI0 - MISO	ABDAC - DATAN[0]
	42	PA29	GPIO 29	TC - CLK0	TC - CLK1	SPI0 - MOSI	
	15	PA30	GPIO 30	ADC - AD[6]	EIC - SCAN[0]	PM - GCLK[2]	
	16	PA31	GPIO 31	ADC - AD[7]	EIC - SCAN[1]	PWM - PWM[6]	
	6	PB00	GPIO 32	TC - A0	EIC - SCAN[2]	USART2 - CTS	
	7	PB01	GPIO 33	TC - B0	EIC - SCAN[3]	USART2 - RTS	
	24	PB02	GPIO 34	EIC - EXTINT[6]	TC - A1	USART1 - TXD	
	25	PB03	GPIO 35	EIC - EXTINT[7]	TC - B1	USART1 - RXD	
	26	PB04	GPIO 36	USART1 - CTS	SPI0 - NPCS[3]	TC - CLK2	
	27	PB05	GPIO 37	USART1 - RTS	SPI0 - NPCS[2]	PWM - PWM[5]	
	38	PB06	GPIO 38	SSC - RX_CLOCK	USART1 - DCD	EIC - SCAN[4]	ABDAC - DATA[0]
	43	PB07	GPIO 39	SSC - RX_DATA	USART1 - DSR	EIC - SCAN[5]	ABDAC - DATAN[0]
	54	PB08	GPIO 40	SSC - RX_FRAME_SYNC	USART1 - DTR	EIC - SCAN[6]	ABDAC - DATA[1]



**Table 4-1.** GPIO Controller Function Multiplexing

	55	PB09	GPIO 41	SSC - TX_CLOCK	USART1 - RI	EIC - SCAN[7]	ABDAC - DATAN[1]
	57	PB10	GPIO 42	SSC - TX_DATA	TC - A2	USART0 - RXD	
	58	PB11	GPIO 43	SSC - TX_FRAME_SYNC	TC - B2	USART0 - TXD	

## 4.2.2 JTAG Port Connections

If the JTAG is enabled, the JTAG will take control over a number of pins, irrespective of the I/O Controller configuration.

**Table 4-2.** JTAG Pinout

64QFP/QFN	48QFP/QFN	Pin name	JTAG pin
2	2	TCK	TCK
3	3	PA00	TDI
4	4	PA01	TDO
5	5	PA02	TMS

## 4.2.3 Nexus OCD AUX port connections

If the OCD trace system is enabled, the trace system will take control over a number of pins, irrespective of the PIO configuration. Two different OCD trace pin mappings are possible, depending on the configuration of the OCD AXS register. For details, see the AVR32 UC Technical Reference Manual.

**Table 4-3.** Nexus OCD AUX port connections

Pin	AXS=0	AXS=1
EVTI_N	PB05	PA14
MDO[5]	PB04	PA08
MDO[4]	PB03	PA07
MDO[3]	PB02	PA06
MDO[2]	PB01	PA05
MDO[1]	PB00	PA04
MDO[0]	PA31	PA03
EVTO_N	PA15	PA15
MCKO	PA30	PA13
MSEO[1]	PB06	PA09
MSEO[0]	PB07	PA10

## 4.2.4 Oscillator Pinout

The oscillators are not mapped to the normal A, B or C functions and their muxings are controlled by registers in the Power Manager (PM). Please refer to the power manager chapter for more information about this.

**Table 4-4.** Oscillator pinout

QFP48 pin	QFP64 pin	Pad	Oscillator pin
30	39	PA18	XIN0
	41	PA28	XIN1
22	30	PA11	XIN32
31	40	PA19	XOUT0
	42	PA29	XOUT1
23	31	PA12	XOUT32

## 4.3 High Drive Current GPIO

One of GPIOs can be used to drive twice current than other GPIO capability (see Electrical Characteristics section).

**Table 4-5.** High Drive Current GPIO

GPIO Name
PA20
PA21
PA22
PA23

## 5. Signals Description

The following table gives details on the signal name classified by peripheral.

**Table 5-1.** Signal Description List

Signal Name	Function	Type	Active Level	Comments
<b>Power</b>				
VDDPLL	PLL Power Supply	Power Input		1.65V to 1.95 V
VDDCORE	Core Power Supply	Power Input		1.65V to 1.95 V
VDDIO	I/O Power Supply	Power Input		3.0V to 3.6V
VDDANA	Analog Power Supply	Power Input		3.0V to 3.6V
VDDIN	Voltage Regulator Input Supply	Power Input		3.0V to 3.6V

**Table 5-1.** Signal Description List (Continued)

Signal Name	Function	Type	Active Level	Comments
VDDOUT	Voltage Regulator Output	Power Output		1.65V to 1.95 V
GNDANA	Analog Ground	Ground		
GND	Ground	Ground		
<b>Clocks, Oscillators, and PLL's</b>				
XIN0, XIN1, XIN32	Crystal 0, 1, 32 Input	Analog		
XOUT0, XOUT1, XOUT32	Crystal 0, 1, 32 Output	Analog		
<b>JTAG</b>				
TCK	Test Clock	Input		
TDI	Test Data In	Input		
TDO	Test Data Out	Output		
TMS	Test Mode Select	Input		
<b>Auxiliary Port - AUX</b>				
MCKO	Trace Data Output Clock	Output		
MDO0 - MDO5	Trace Data Output	Output		
MSEO0 - MSEO1	Trace Frame Control	Output		
EVTI_N	Event In	Output	Low	
EVTO_N	Event Out	Output	Low	
<b>Power Manager - PM</b>				
GCLK0 - GCLK2	Generic Clock Pins	Output		
RESET_N	Reset Pin	Input	Low	
<b>External Interrupt Controller - EIC</b>				
EXTINT0 - EXTINT7	External Interrupt Pins	Input		
KPS0 - KPS7	Keypad Scan Pins	Output		
NMI	Non-Maskable Interrupt Pin	Input	Low	
<b>General Purpose I/O pin- GPIOA, GPIOB</b>				
PA0 - PA31	Parallel I/O Controller GPIOA	I/O		
PB0 - PB11	Parallel I/O Controller GPIOB	I/O		

**Table 5-1.** Signal Description List (Continued)

Signal Name	Function	Type	Active Level	Comments
<b>Serial Peripheral Interface - SPI0</b>				
MISO	Master In Slave Out	I/O		
MOSI	Master Out Slave In	I/O		
NPCS0 - NPCS3	SPI Peripheral Chip Select	I/O	Low	
SCK	Clock	Output		
<b>Synchronous Serial Controller - SSC</b>				
RX_CLOCK	SSC Receive Clock	I/O		
RX_DATA	SSC Receive Data	Input		
RX_FRAME_SYNC	SSC Receive Frame Sync	I/O		
TX_CLOCK	SSC Transmit Clock	I/O		
TX_DATA	SSC Transmit Data	Output		
TX_FRAME_SYNC	SSC Transmit Frame Sync	I/O		
<b>Timer/Counter - TIMER</b>				
A0	Channel 0 Line A	I/O		
A1	Channel 1 Line A	I/O		
A2	Channel 2 Line A	I/O		
B0	Channel 0 Line B	I/O		
B1	Channel 1 Line B	I/O		
B2	Channel 2 Line B	I/O		
CLK0	Channel 0 External Clock Input	Input		
CLK1	Channel 1 External Clock Input	Input		
CLK2	Channel 2 External Clock Input	Input		
<b>Two-wire Interface - TWI</b>				
SCL	Serial Clock	I/O		
SDA	Serial Data	I/O		
<b>Universal Synchronous Asynchronous Receiver Transmitter - USART0, USART1, USART2</b>				
CLK	Clock	I/O		
CTS	Clear To Send	Input		

**Table 5-1.** Signal Description List (Continued)

Signal Name	Function	Type	Active Level	Comments
DCD	Data Carrier Detect			Only USART1
DSR	Data Set Ready			Only USART1
DTR	Data Terminal Ready			Only USART1
RI	Ring Indicator			Only USART1
RTS	Request To Send	Output		
RXD	Receive Data	Input		
TXD	Transmit Data	Output		
<b>Analog to Digital Converter - ADC</b>				
AD0 - AD7	Analog input pins	Analog input		
ADVREF	Analog positive reference voltage input	Analog input		2.6 to 3.6V
<b>Audio Bitstream DAC - ABDAC</b>				
DATA0 - DATA1	D/A Data out	Output		
DATAN0 - DATAN1	D/A Data inverted out	Output		
<b>Pulse Width Modulator - PWM</b>				
PWM0 - PWM6	PWM Output Pins	Output		
<b>Universal Serial Bus Device - USBB</b>				
DDM	USB Device Port Data -	Analog		
DDP	USB Device Port Data +	Analog		
VBUS	USB VBUS Monitor and Embedded Host Negotiation	Analog Input		
USBID	ID Pin of the USB Bus	Input		
USB_VBOF	USB VBUS On/off: bus power control port	output		

## 5.1 JTAG pins

TMS and TDI pins have pull-up resistors. TDO pin is an output, driven at up to VDDIO, and has no pull-up resistor. These 3 pins can be used as GPIO-pins. At reset state, these pins are in GPIO mode.

TCK pin cannot be used as GPIO pin. JTAG interface is enabled when TCK pin is tied low.

## 5.2 RESET\_N pin

The RESET\_N pin is a schmitt input and integrates a permanent pull-up resistor to VDDIO. As the product integrates a power-on reset cell, the RESET\_N pin can be left unconnected in case no reset from the system needs to be applied to the product.

## 5.3 TWI pins

When these pins are used for TWI, the pins are open-drain outputs with slew-rate limitation and inputs with inputs with spike-filtering. When used as GPIO-pins or used for other peripherals, the pins have the same characteristics as GPIO pins.

## 5.4 GPIO pins

All the I/O lines integrate a pull-up resistor. Programming of this pull-up resistor is performed independently for each I/O line through the GPIO Controllers. After reset, I/O lines default as inputs with pull-up resistors disabled, except when indicated otherwise in the column "Reset Value" of the GPIO Controller user interface table.

## 5.5 High drive pins

The four pins PA20, PA21, PA22, PA23 have high drive output capabilities.

## 5.6 Power Considerations

### 5.6.1 Power Supplies

The AT32UC3B has several types of power supply pins:

- **VDDIO: Powers I/O lines. Voltage is 3.3V nominal.**
- **VDDANA: Powers the ADC Voltage is 3.3V nominal.**
- **VDDIN: Input voltage for the voltage regulator. Voltage is 3.3V nominal.**
- **VDDCORE: Powers the core, memories, and peripherals. Voltage is 1.8V nominal.**
- **VDDPLL: Powers the PLL. Voltage is 1.8V nominal.**

The ground pins GND are common to VDDCORE, VDDIO and VDDPLL. The ground pin for VDDANA is GNDANA.

Refer to Electrical Characteristics section for power consumption on the various supply pins.

The main requirement for power supplies connection is to respect a star topology for all electrical connection.

Figure 5-1. Power Supply

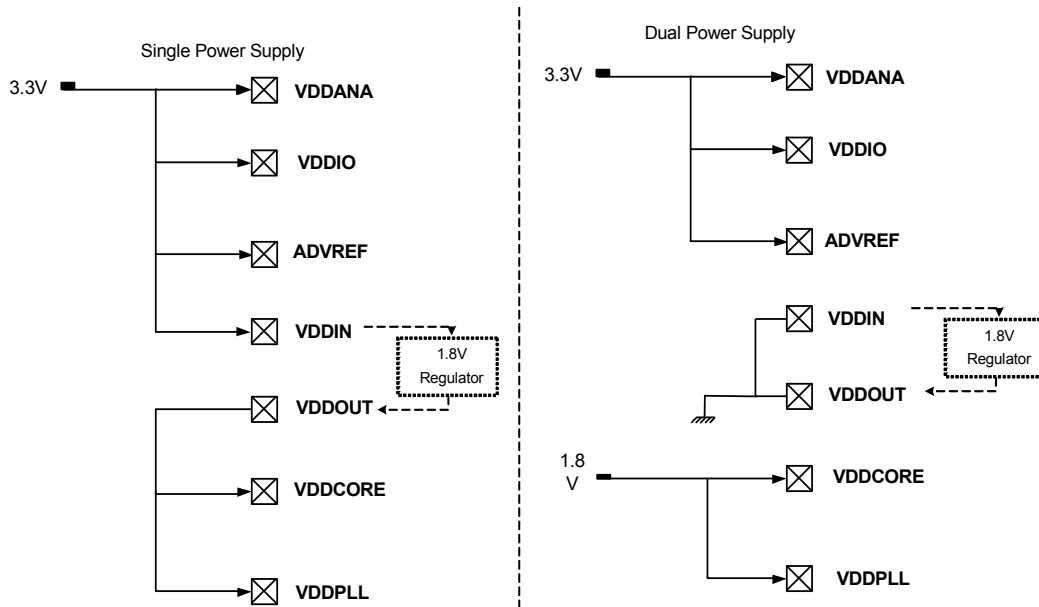

5.6.2 Voltage Regulator

5.6.2.1 Single Power Supply

The AT32UC3B embeds a voltage regulator that converts from 3.3V to 1.8V. The regulator takes its input voltage from VDDIN, and supplies the output voltage on VDDOUT that should be externally connected to the 1.8V domains.

Adequate input supply decoupling is mandatory for VDDIN in order to improve startup stability and reduce source voltage drop. Two input decoupling capacitors must be placed close to the chip.

Adequate output supply decoupling is mandatory for VDDOUT to reduce ripple and avoid oscillations. The best way to achieve this is to use two capacitors in parallel between VDDOUT and GND as close to the chip as possible

Figure 5-2. Supply Decoupling

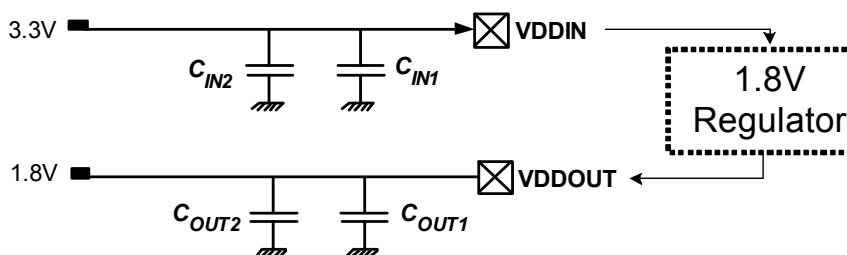

Refer to [Section 9.3 on page 38](#) for decoupling capacitors values and regulator characteristics.

For decoupling recommendations for VDDIO, VDDANA, VDDCORE and VDDPLL, please refer to the Schematic checklist.

### 5.6.2.2 Dual Power Supply

In case of dual power supply, VDDIN and VDDOUT should be connected to ground to prevent from leakage current.

To avoid over consumption during the power up sequence, VDDIO and VDDCORE voltage difference needs to stay in the range given [Figure 5-3](#).

**Figure 5-3.** VDDIO versus VDDCORE during power up sequence

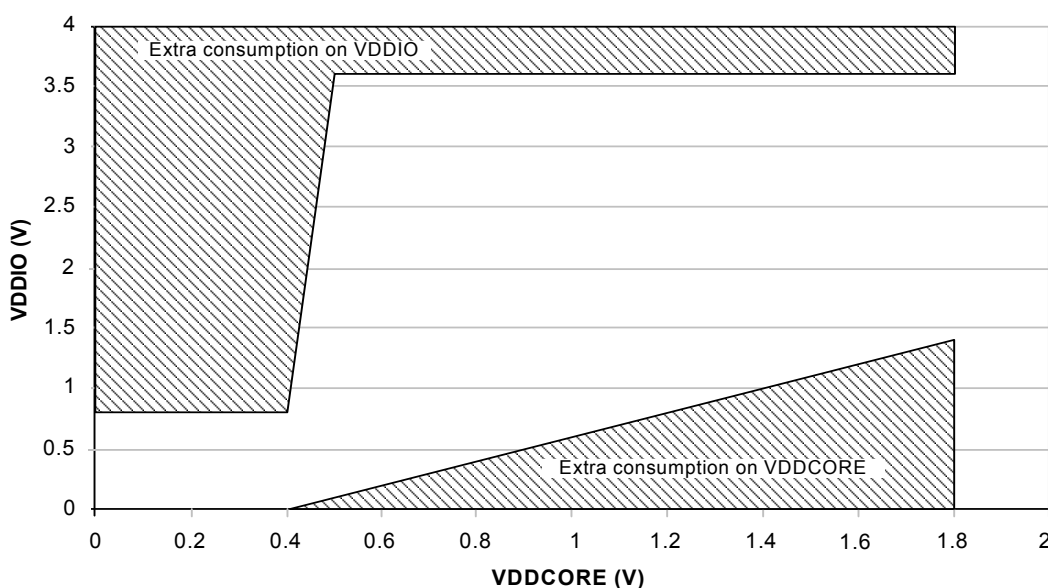

### 5.6.3 Analog-to-Digital Converter (ADC) reference.

The ADC reference (ADVREF) must be provided from an external source. Two decoupling capacitors must be used to insure proper decoupling.

**Figure 5-4.** ADVREF Decoupling

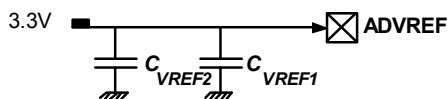

Refer to [Section 9.4 on page 38](#) for decoupling capacitors values and electrical characteristics.

In case ADC is not used, the ADVREF pin should be connected to GND to avoid extra consumption.



## 6. Processor and Architecture

Rev: 1.0.0.0

This chapter gives an overview of the AVR32UC CPU. AVR32UC is an implementation of the AVR32 architecture. A summary of the programming model, instruction set, and MPU is presented. For further details, see the *AVR32 Architecture Manual* and the *AVR32UC Technical Reference Manual*.

### 6.1 Features

- **32-bit load/store AVR32A RISC architecture**
  - 15 general-purpose 32-bit registers
  - 32-bit Stack Pointer, Program Counter and Link Register reside in register file
  - Fully orthogonal instruction set
  - Privileged and unprivileged modes enabling efficient and secure Operating Systems
  - Innovative instruction set together with variable instruction length ensuring industry leading code density
  - DSP extention with saturating arithmetic, and a wide variety of multiply instructions
- **3-stage pipeline allows one instruction per clock cycle for most instructions**
  - Byte, halfword, word and double word memory access
  - Multiple interrupt priority levels
- **MPU allows for operating systems with memory protection**

### 6.2 AVR32 Architecture

AVR32 is a high-performance 32-bit RISC microprocessor architecture, designed for cost-sensitive embedded applications, with particular emphasis on low power consumption and high code density. In addition, the instruction set architecture has been tuned to allow a variety of micro-architectures, enabling the AVR32 to be implemented as low-, mid-, or high-performance processors. AVR32 extends the AVR family into the world of 32- and 64-bit applications.

Through a quantitative approach, a large set of industry recognized benchmarks has been compiled and analyzed to achieve the best code density in its class. In addition to lowering the memory requirements, a compact code size also contributes to the core's low power characteristics. The processor supports byte and halfword data types without penalty in code size and performance.

Memory load and store operations are provided for byte, halfword, word, and double word data with automatic sign- or zero extension of halfword and byte data. The C-compiler is closely linked to the architecture and is able to exploit code optimization features, both for size and speed.

In order to reduce code size to a minimum, some instructions have multiple addressing modes. As an example, instructions with immediates often have a compact format with a smaller immediate, and an extended format with a larger immediate. In this way, the compiler is able to use the format giving the smallest code size.

Another feature of the instruction set is that frequently used instructions, like add, have a compact format with two operands as well as an extended format with three operands. The larger format increases performance, allowing an addition and a data move in the same instruction in a single cycle. Load and store instructions have several different formats in order to reduce code size and speed up execution.

The register file is organized as sixteen 32-bit registers and includes the Program Counter, the Link Register, and the Stack Pointer. In addition, register R12 is designed to hold return values from function calls and is used implicitly by some instructions.

### 6.3 The AVR32UC CPU

The AVR32UC CPU targets low- and medium-performance applications, and provides an advanced OCD system, no caches, and a Memory Protection Unit (MPU). Java acceleration hardware is not implemented.

AVR32UC provides three memory interfaces, one High Speed Bus master for instruction fetch, one High Speed Bus master for data access, and one High Speed Bus slave interface allowing other bus masters to access data RAMs internal to the CPU. Keeping data RAMs internal to the CPU allows fast access to the RAMs, reduces latency, and guarantees deterministic timing. Also, power consumption is reduced by not needing a full High Speed Bus access for memory accesses. A dedicated data RAM interface is provided for communicating with the internal data RAMs.

A local bus interface is provided for connecting the CPU to device-specific high-speed systems, such as floating-point units and fast GPIO ports. This local bus has to be enabled by writing the LOCEN bit in the CPUCR system register. The local bus is able to transfer data between the CPU and the local bus slave in a single clock cycle. The local bus has a dedicated memory range allocated to it, and data transfers are performed using regular load and store instructions. Details on which devices that are mapped into the local bus space is given in the Memories chapter of this data sheet.

[Figure 6-1 on page 19](#) displays the contents of AVR32UC.

Figure 6-1. Overview of the AVR32UC CPU

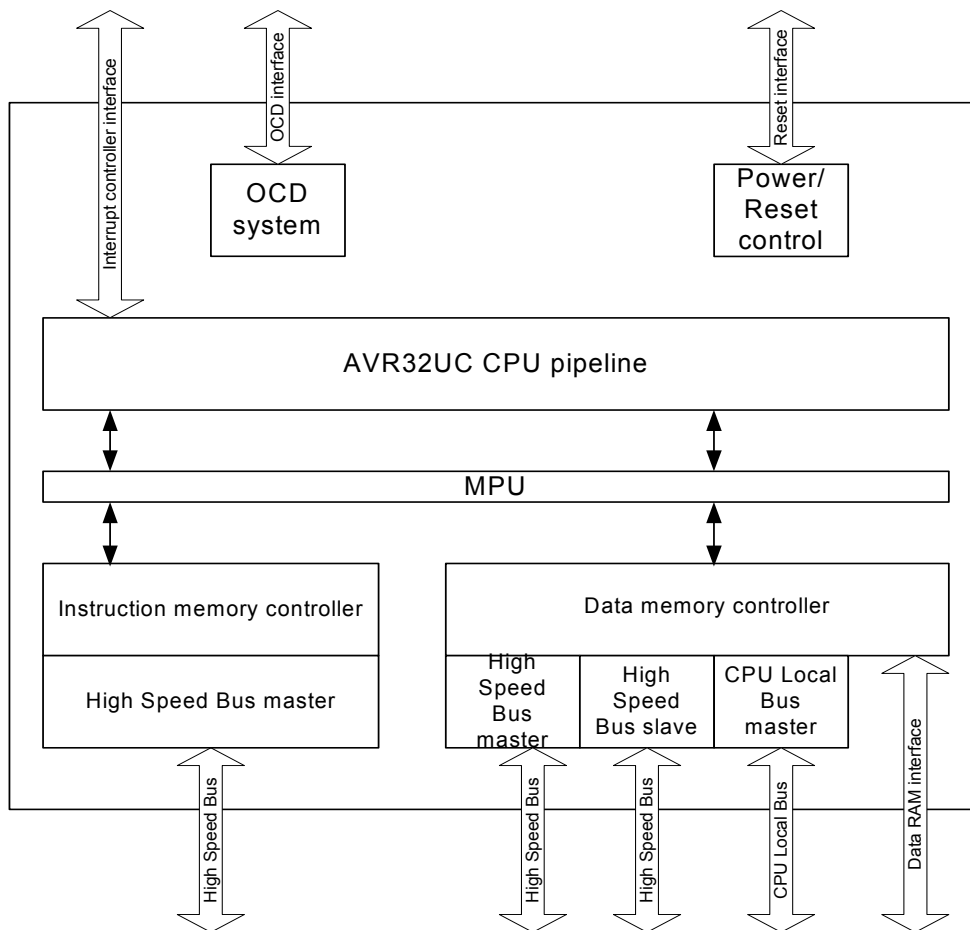

### 6.3.1 Pipeline Overview

AVR32UC has three pipeline stages, Instruction Fetch (IF), Instruction Decode (ID), and Instruction Execute (EX). The EX stage is split into three parallel subsections, one arithmetic/logic (ALU) section, one multiply (MUL) section, and one load/store (LS) section.

Instructions are issued and complete in order. Certain operations require several clock cycles to complete, and in this case, the instruction resides in the ID and EX stages for the required number of clock cycles. Since there is only three pipeline stages, no internal data forwarding is required, and no data dependencies can arise in the pipeline.

Figure 6-2 on page 20 shows an overview of the AVR32UC pipeline stages.

Figure 6-2. The AVR32UC Pipeline

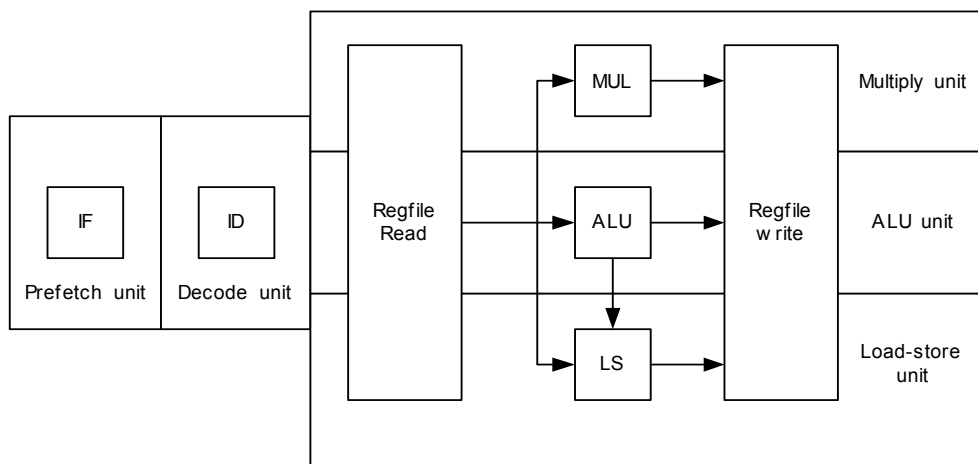

### 6.3.2 AVR32A Microarchitecture Compliance

AVR32UC implements an AVR32A microarchitecture. The AVR32A microarchitecture is targeted at cost-sensitive, lower-end applications like smaller microcontrollers. This microarchitecture does not provide dedicated hardware registers for shadowing of register file registers in interrupt contexts. Additionally, it does not provide hardware registers for the return address registers and return status registers. Instead, all this information is stored on the system stack. This saves chip area at the expense of slower interrupt handling.

Upon interrupt initiation, registers R8-R12 are automatically pushed to the system stack. These registers are pushed regardless of the priority level of the pending interrupt. The return address and status register are also automatically pushed to stack. The interrupt handler can therefore use R8-R12 freely. Upon interrupt completion, the old R8-R12 registers and status register are restored, and execution continues at the return address stored popped from stack.

The stack is also used to store the status register and return address for exceptions and *scall*. Executing the *rete* or *rets* instruction at the completion of an exception or system call will pop this status register and continue execution at the popped return address.

### 6.3.3 Java Support

AVR32UC does not provide Java hardware acceleration.

### 6.3.4 Memory Protection

The MPU allows the user to check all memory accesses for privilege violations. If an access is attempted to an illegal memory address, the access is aborted and an exception is taken. The MPU in AVR32UC is specified in the AVR32UC Technical Reference manual.

### 6.3.5 Unaligned Reference Handling

AVR32UC does not support unaligned accesses, except for doubleword accesses. AVR32UC is able to perform word-aligned *st.d* and *ld.d*. Any other unaligned memory access will cause an address exception. Doubleword-sized accesses with word-aligned pointers will automatically be performed as two word-sized accesses.

The following table shows the instructions with support for unaligned addresses. All other instructions require aligned addresses.

**Table 6-1.** Instructions with Unaligned Reference Support

Instruction	Supported alignment
ld.d	Word
st.d	Word

### 6.3.6 Unimplemented Instructions

The following instructions are unimplemented in AVR32UC, and will cause an Unimplemented Instruction Exception if executed:

- All SIMD instructions
- All coprocessor instructions if no coprocessors are present
- retj, incjosp, popjc, pushjc
- tlbr, tlbs, tlbw
- cache

### 6.3.7 CPU and Architecture Revision

Three major revisions of the AVR32UC CPU currently exist.

The Architecture Revision field in the CONFIG0 system register identifies which architecture revision is implemented in a specific device.

AVR32UC CPU revision 3 is fully backward-compatible with revisions 1 and 2, ie. code compiled for revision 1 or 2 is binary-compatible with revision 3 CPUs.

## 6.4 Programming Model

### 6.4.1 Register File Configuration

The AVR32UC register file is shown below.

**Figure 6-3.** The AVR32UC Register File

Application		Supervisor		INT0		INT1		INT2		INT3		Exception		NMI		Secure	
Bit 31	Bit 0	Bit 31	Bit 0	Bit 31	Bit 0	Bit 31	Bit 0	Bit 31	Bit 0	Bit 31	Bit 0	Bit 31	Bit 0	Bit 31	Bit 0	Bit 31	Bit 0
PC	PC	PC	PC	PC	PC	PC	PC	PC	PC	PC	PC	PC	PC	PC	PC	PC	PC
LR	LR	LR	LR	LR	LR	LR	LR	LR	LR	LR	LR	LR	LR	LR	LR	LR	LR
SP_APP	SP_SYS	SP_SYS	SP_SYS	SP_SYS	SP_SYS	SP_SYS	SP_SYS	SP_SYS	SP_SYS	SP_SYS	SP_SYS	SP_SYS	SP_SYS	SP_SYS	SP_SYS	SP_SEC	SP_SEC
R12	R12	R12	R12	R12	R12	R12	R12	R12	R12	R12	R12	R12	R12	R12	R12	R12	R12
R11	R11	R11	R11	R11	R11	R11	R11	R11	R11	R11	R11	R11	R11	R11	R11	R11	R11
R10	R10	R10	R10	R10	R10	R10	R10	R10	R10	R10	R10	R10	R10	R10	R10	R10	R10
R9	R9	R9	R9	R9	R9	R9	R9	R9	R9	R9	R9	R9	R9	R9	R9	R9	R9
R8	R8	R8	R8	R8	R8	R8	R8	R8	R8	R8	R8	R8	R8	R8	R8	R8	R8
R7	R7	R7	R7	R7	R7	R7	R7	R7	R7	R7	R7	R7	R7	R7	R7	R7	R7
R6	R6	R6	R6	R6	R6	R6	R6	R6	R6	R6	R6	R6	R6	R6	R6	R6	R6
R5	R5	R5	R5	R5	R5	R5	R5	R5	R5	R5	R5	R5	R5	R5	R5	R5	R5
R4	R4	R4	R4	R4	R4	R4	R4	R4	R4	R4	R4	R4	R4	R4	R4	R4	R4
R3	R3	R3	R3	R3	R3	R3	R3	R3	R3	R3	R3	R3	R3	R3	R3	R3	R3
R2	R2	R2	R2	R2	R2	R2	R2	R2	R2	R2	R2	R2	R2	R2	R2	R2	R2
R1	R1	R1	R1	R1	R1	R1	R1	R1	R1	R1	R1	R1	R1	R1	R1	R1	R1
R0	R0	R0	R0	R0	R0	R0	R0	R0	R0	R0	R0	R0	R0	R0	R0	R0	R0
SR	SR	SR	SR	SR	SR	SR	SR	SR	SR	SR	SR	SR	SR	SR	SR	SR	SR

  

SS_STATUS
SS_ADRF
SS_ADDR
SS_ADR0
SS_ADR1
SS_SP_SYS
SS_SP_APP
SS_RAR
SS_RSR

### 6.4.2 Status Register Configuration

The Status Register (SR) is split into two halfwords, one upper and one lower, see [Figure 6-4 on page 22](#) and [Figure 6-5 on page 23](#). The lower word contains the C, Z, N, V, and Q condition code flags and the R, T, and L bits, while the upper halfword contains information about the mode and state the processor executes in. Refer to the *AVR32 Architecture Manual* for details.

**Figure 6-4.** The Status Register High Halfword

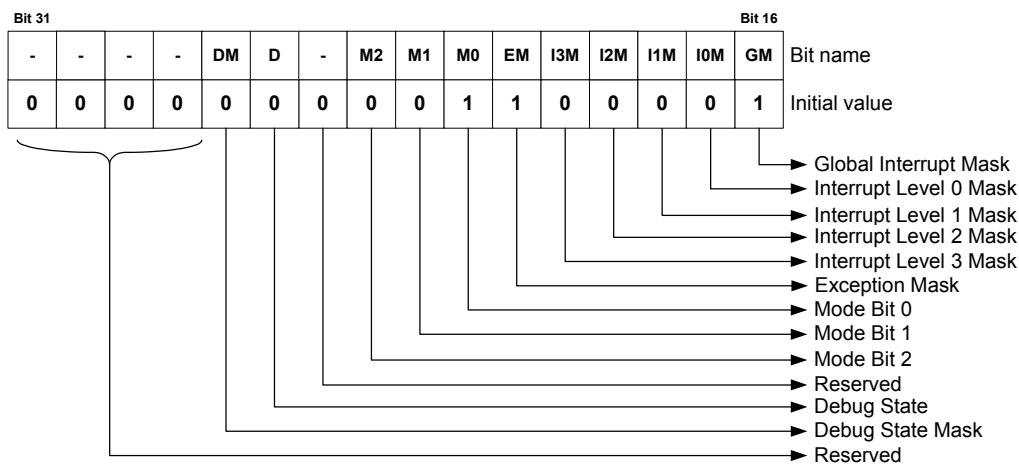

**Figure 6-5.** The Status Register Low Halfword

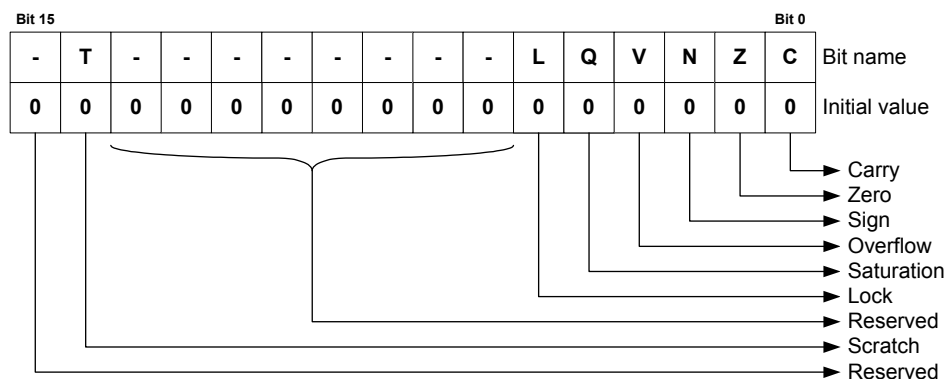

## 6.4.3 Processor States

### 6.4.3.1 Normal RISC State

The AVR32 processor supports several different execution contexts as shown in [Table 6-2 on page 23](#).

**Table 6-2.** Overview of Execution Modes, their Priorities and Privilege Levels.

Priority	Mode	Security	Description
1	Non Maskable Interrupt	Privileged	Non Maskable high priority interrupt mode
2	Exception	Privileged	Execute exceptions
3	Interrupt 3	Privileged	General purpose interrupt mode
4	Interrupt 2	Privileged	General purpose interrupt mode
5	Interrupt 1	Privileged	General purpose interrupt mode
6	Interrupt 0	Privileged	General purpose interrupt mode
N/A	Supervisor	Privileged	Runs supervisor calls
N/A	Application	Unprivileged	Normal program execution mode

Mode changes can be made under software control, or can be caused by external interrupts or exception processing. A mode can be interrupted by a higher priority mode, but never by one with lower priority. Nested exceptions can be supported with a minimal software overhead.

When running an operating system on the AVR32, user processes will typically execute in the application mode. The programs executed in this mode are restricted from executing certain instructions. Furthermore, most system registers together with the upper halfword of the status register cannot be accessed. Protected memory areas are also not available. All other operating modes are privileged and are collectively called System Modes. They have full access to all privileged and unprivileged resources. After a reset, the processor will be in supervisor mode.

### 6.4.3.2 Debug State

The AVR32 can be set in a debug state, which allows implementation of software monitor routines that can read out and alter system information for use during application development. This implies that all system and application registers, including the status registers and program counters, are accessible in debug state. The privileged instructions are also available.

All interrupt levels are by default disabled when debug state is entered, but they can individually be switched on by the monitor routine by clearing the respective mask bit in the status register.

Debug state can be entered as described in the *AVR32UC Technical Reference Manual*.

Debug state is exited by the *retd* instruction.

## 6.4.4 System Registers

The system registers are placed outside of the virtual memory space, and are only accessible using the privileged *mfsr* and *mtsr* instructions. The table below lists the system registers specified in the AVR32 architecture, some of which are unused in AVR32UC. The programmer is responsible for maintaining correct sequencing of any instructions following a *mtsr* instruction. For detail on the system registers, refer to the *AVR32UC Technical Reference Manual*.

**Table 6-3.** System Registers

Reg #	Address	Name	Function
0	0	SR	Status Register
1	4	EVBA	Exception Vector Base Address
2	8	ACBA	Application Call Base Address
3	12	CPUCR	CPU Control Register
4	16	ECR	Exception Cause Register
5	20	RSR_SUP	Unused in AVR32UC
6	24	RSR_INT0	Unused in AVR32UC
7	28	RSR_INT1	Unused in AVR32UC
8	32	RSR_INT2	Unused in AVR32UC
9	36	RSR_INT3	Unused in AVR32UC
10	40	RSR_EX	Unused in AVR32UC
11	44	RSR_NMI	Unused in AVR32UC
12	48	RSR_DBG	Return Status Register for Debug mode
13	52	RAR_SUP	Unused in AVR32UC
14	56	RAR_INT0	Unused in AVR32UC
15	60	RAR_INT1	Unused in AVR32UC
16	64	RAR_INT2	Unused in AVR32UC
17	68	RAR_INT3	Unused in AVR32UC
18	72	RAR_EX	Unused in AVR32UC
19	76	RAR_NMI	Unused in AVR32UC
20	80	RAR_DBG	Return Address Register for Debug mode
21	84	JECR	Unused in AVR32UC
22	88	JOSP	Unused in AVR32UC
23	92	JAVA_LV0	Unused in AVR32UC
24	96	JAVA_LV1	Unused in AVR32UC
25	100	JAVA_LV2	Unused in AVR32UC



**Table 6-3.** System Registers (Continued)

Reg #	Address	Name	Function
26	104	JAVA_LV3	Unused in AVR32UC
27	108	JAVA_LV4	Unused in AVR32UC
28	112	JAVA_LV5	Unused in AVR32UC
29	116	JAVA_LV6	Unused in AVR32UC
30	120	JAVA_LV7	Unused in AVR32UC
31	124	JTBA	Unused in AVR32UC
32	128	JBCR	Unused in AVR32UC
33-63	132-252	Reserved	Reserved for future use
64	256	CONFIG0	Configuration register 0
65	260	CONFIG1	Configuration register 1
66	264	COUNT	Cycle Counter register
67	268	COMPARE	Compare register
68	272	TLBEHI	Unused in AVR32UC
69	276	TLBELO	Unused in AVR32UC
70	280	PTBR	Unused in AVR32UC
71	284	TLBEAR	Unused in AVR32UC
72	288	MMUCR	Unused in AVR32UC
73	292	TLBARLO	Unused in AVR32UC
74	296	TLBARHI	Unused in AVR32UC
75	300	PCCNT	Unused in AVR32UC
76	304	PCNT0	Unused in AVR32UC
77	308	PCNT1	Unused in AVR32UC
78	312	PCCR	Unused in AVR32UC
79	316	BEAR	Bus Error Address Register
80	320	MPUAR0	MPU Address Register region 0
81	324	MPUAR1	MPU Address Register region 1
82	328	MPUAR2	MPU Address Register region 2
83	332	MPUAR3	MPU Address Register region 3
84	336	MPUAR4	MPU Address Register region 4
85	340	MPUAR5	MPU Address Register region 5
86	344	MPUAR6	MPU Address Register region 6
87	348	MPUAR7	MPU Address Register region 7
88	352	MPUPSR0	MPU Privilege Select Register region 0
89	356	MPUPSR1	MPU Privilege Select Register region 1
90	360	MPUPSR2	MPU Privilege Select Register region 2
91	364	MPUPSR3	MPU Privilege Select Register region 3

**Table 6-3.** System Registers (Continued)

Reg #	Address	Name	Function
92	368	MPUPSR4	MPU Privilege Select Register region 4
93	372	MPUPSR5	MPU Privilege Select Register region 5
94	376	MPUPSR6	MPU Privilege Select Register region 6
95	380	MPUPSR7	MPU Privilege Select Register region 7
96	384	MPUCRA	Unused in this version of AVR32UC
97	388	MPUCRB	Unused in this version of AVR32UC
98	392	MPUBRA	Unused in this version of AVR32UC
99	396	MPUBRB	Unused in this version of AVR32UC
100	400	MPUAPRA	MPU Access Permission Register A
101	404	MPUAPRB	MPU Access Permission Register B
102	408	MPUCR	MPU Control Register
103-191	448-764	Reserved	Reserved for future use
192-255	768-1020	IMPL	IMPLEMENTATION DEFINED

## 6.5 Exceptions and Interrupts

AVR32UC incorporates a powerful exception handling scheme. The different exception sources, like Illegal Op-code and external interrupt requests, have different priority levels, ensuring a well-defined behavior when multiple exceptions are received simultaneously. Additionally, pending exceptions of a higher priority class may preempt handling of ongoing exceptions of a lower priority class.

When an event occurs, the execution of the instruction stream is halted, and execution control is passed to an event handler at an address specified in [Table 6-4 on page 29](#). Most of the handlers are placed sequentially in the code space starting at the address specified by EVBA, with four bytes between each handler. This gives ample space for a jump instruction to be placed there, jumping to the event routine itself. A few critical handlers have larger spacing between them, allowing the entire event routine to be placed directly at the address specified by the EVBA-relative offset generated by hardware. All external interrupt sources have autovector interrupt service routine (ISR) addresses. This allows the interrupt controller to directly specify the ISR address as an address relative to EVBA. The autovector offset has 14 address bits, giving an offset of maximum 16384 bytes. The target address of the event handler is calculated as  $(EVBA \mid event\_handler\_offset)$ , not  $(EVBA + event\_handler\_offset)$ , so EVBA and exception code segments must be set up appropriately. The same mechanisms are used to service all different types of events, including external interrupt requests, yielding a uniform event handling scheme.

An interrupt controller does the priority handling of the external interrupts and provides the autovector offset to the CPU.

### 6.5.1 System Stack Issues

Event handling in AVR32UC uses the system stack pointed to by the system stack pointer, SP\_SYS, for pushing and popping R8-R12, LR, status register, and return address. Since event code may be timing-critical, SP\_SYS should point to memory addresses in the IRAM section, since the timing of accesses to this memory section is both fast and deterministic.

The user must also make sure that the system stack is large enough so that any event is able to push the required registers to stack. If the system stack is full, and an event occurs, the system will enter an UNDEFINED state.

### 6.5.2 Exceptions and Interrupt Requests

When an event other than *scall* or debug request is received by the core, the following actions are performed atomically:

1. The pending event will not be accepted if it is masked. The I3M, I2M, I1M, I0M, EM, and GM bits in the Status Register are used to mask different events. Not all events can be masked. A few critical events (NMI, Unrecoverable Exception, TLB Multiple Hit, and Bus Error) can not be masked. When an event is accepted, hardware automatically sets the mask bits corresponding to all sources with equal or lower priority. This inhibits acceptance of other events of the same or lower priority, except for the critical events listed above. Software may choose to clear some or all of these bits after saving the necessary state if other priority schemes are desired. It is the event source's responsibility to ensure that their events are left pending until accepted by the CPU.
2. When a request is accepted, the Status Register and Program Counter of the current context is stored to the system stack. If the event is an INT0, INT1, INT2, or INT3, registers R8-R12 and LR are also automatically stored to stack. Storing the Status Register ensures that the core is returned to the previous execution mode when the current event handling is completed. When exceptions occur, both the EM and GM bits are set, and the application may manually enable nested exceptions if desired by clearing the appropriate bit. Each exception handler has a dedicated handler address, and this address uniquely identifies the exception source.
3. The Mode bits are set to reflect the priority of the accepted event, and the correct register file bank is selected. The address of the event handler, as shown in Table 6-4, is loaded into the Program Counter.

The execution of the event handler routine then continues from the effective address calculated.

The *rete* instruction signals the end of the event. When encountered, the Return Status Register and Return Address Register are popped from the system stack and restored to the Status Register and Program Counter. If the *rete* instruction returns from INT0, INT1, INT2, or INT3, registers R8-R12 and LR are also popped from the system stack. The restored Status Register contains information allowing the core to resume operation in the previous execution mode. This concludes the event handling.

### 6.5.3 Supervisor Calls

The AVR32 instruction set provides a supervisor mode call instruction. The *scall* instruction is designed so that privileged routines can be called from any context. This facilitates sharing of code between different execution modes. The *scall* mechanism is designed so that a minimal execution cycle overhead is experienced when performing supervisor routine calls from time-critical event handlers.

The *scall* instruction behaves differently depending on which mode it is called from. The behaviour is detailed in the instruction set reference. In order to allow the *scall* routine to return to the correct context, a return from supervisor call instruction, *rets*, is implemented. In the AVR32UC CPU, *scall* and *rets* uses the system stack to store the return address and the status register.

### 6.5.4 Debug Requests

The AVR32 architecture defines a dedicated Debug mode. When a debug request is received by the core, Debug mode is entered. Entry into Debug mode can be masked by the DM bit in the

status register. Upon entry into Debug mode, hardware sets the SR[D] bit and jumps to the Debug Exception handler. By default, Debug mode executes in the exception context, but with dedicated Return Address Register and Return Status Register. These dedicated registers remove the need for storing this data to the system stack, thereby improving debuggability. The mode bits in the status register can freely be manipulated in Debug mode, to observe registers in all contexts, while retaining full privileges.

Debug mode is exited by executing the *retd* instruction. This returns to the previous context.

### 6.5.5 Entry Points for Events

Several different event handler entry points exist. In AVR32UC, the reset address is 0x8000\_0000. This places the reset address in the boot flash memory area.

TLB miss exceptions and *scall* have a dedicated space relative to EVBA where their event handler can be placed. This speeds up execution by removing the need for a jump instruction placed at the program address jumped to by the event hardware. All other exceptions have a dedicated event routine entry point located relative to EVBA. The handler routine address identifies the exception source directly.

AVR32UC uses the ITLB and DTLB protection exceptions to signal a MPU protection violation. ITLB and DTLB miss exceptions are used to signal that an access address did not map to any of the entries in the MPU. TLB multiple hit exception indicates that an access address did map to multiple TLB entries, signalling an error.

All external interrupt requests have entry points located at an offset relative to EVBA. This autovector offset is specified by an external Interrupt Controller. The programmer must make sure that none of the autovector offsets interfere with the placement of other code. The autovector offset has 14 address bits, giving an offset of maximum 16384 bytes.

Special considerations should be made when loading EVBA with a pointer. Due to security considerations, the event handlers should be located in non-writeable flash memory, or optionally in a privileged memory protection region if an MPU is present.

If several events occur on the same instruction, they are handled in a prioritized way. The priority ordering is presented in Table 6-4. If events occur on several instructions at different locations in the pipeline, the events on the oldest instruction are always handled before any events on any younger instruction, even if the younger instruction has events of higher priority than the oldest instruction. An instruction B is younger than an instruction A if it was sent down the pipeline later than A.

The addresses and priority of simultaneous events are shown in Table 6-4. Some of the exceptions are unused in AVR32UC since it has no MMU, coprocessor interface, or floating-point unit.

**Table 6-4.** Priority and Handler Addresses for Events

Priority	Handler Address	Name	Event source	Stored Return Address
1	0x8000_0000	Reset	External input	Undefined
2	Provided by OCD system	OCD Stop CPU	OCD system	First non-completed instruction
3	EVBA+0x00	Unrecoverable exception	Internal	PC of offending instruction
4	EVBA+0x04	TLB multiple hit	MPU	
5	EVBA+0x08	Bus error data fetch	Data bus	First non-completed instruction
6	EVBA+0x0C	Bus error instruction fetch	Data bus	First non-completed instruction
7	EVBA+0x10	NMI	External input	First non-completed instruction
8	Autovectored	Interrupt 3 request	External input	First non-completed instruction
9	Autovectored	Interrupt 2 request	External input	First non-completed instruction
10	Autovectored	Interrupt 1 request	External input	First non-completed instruction
11	Autovectored	Interrupt 0 request	External input	First non-completed instruction
12	EVBA+0x14	Instruction Address	CPU	PC of offending instruction
13	EVBA+0x50	ITLB Miss	MPU	
14	EVBA+0x18	ITLB Protection	MPU	PC of offending instruction
15	EVBA+0x1C	Breakpoint	OCD system	First non-completed instruction
16	EVBA+0x20	Illegal Opcode	Instruction	PC of offending instruction
17	EVBA+0x24	Unimplemented instruction	Instruction	PC of offending instruction
18	EVBA+0x28	Privilege violation	Instruction	PC of offending instruction
19	EVBA+0x2C	Floating-point	UNUSED	
20	EVBA+0x30	Coprocessor absent	Instruction	PC of offending instruction
21	EVBA+0x100	Supervisor call	Instruction	PC(Supervisor Call) +2
22	EVBA+0x34	Data Address (Read)	CPU	PC of offending instruction
23	EVBA+0x38	Data Address (Write)	CPU	PC of offending instruction
24	EVBA+0x60	DTLB Miss (Read)	MPU	
25	EVBA+0x70	DTLB Miss (Write)	MPU	
26	EVBA+0x3C	DTLB Protection (Read)	MPU	PC of offending instruction
27	EVBA+0x40	DTLB Protection (Write)	MPU	PC of offending instruction
28	EVBA+0x44	DTLB Modified	UNUSED	

## 6.6 Module Configuration

All AT32UC3B parts do not implement the same CPU and Architecture Revision.

**Table 6-5.** CPU and Architecture Revision

Part Name	Architecture Revision
AT32UC3Bx512	2
AT32UC3Bx256	1
AT32UC3Bx128	1
AT32UC3Bx64	1

## 7. Memories

### 7.1 Embedded Memories

- Internal High-Speed Flash
  - 512KBytes (AT32UC3B0512, AT32UC3B1512)
  - 256 KBytes (AT32UC3B0256, AT32UC3B1256)
  - 128 KBytes (AT32UC3B0128, AT32UC3B1128)
  - 64 KBytes (AT32UC3B064, AT32UC3B164)
    - - 0 Wait State Access at up to 30 MHz in Worst Case Conditions
    - - 1 Wait State Access at up to 60 MHz in Worst Case Conditions
    - - Pipelined Flash Architecture, allowing burst reads from sequential Flash locations, hiding penalty of 1 wait state access
    - - 100 000 Write Cycles, 15-year Data Retention Capability
    - - 4 ms Page Programming Time, 8 ms Chip Erase Time
    - - Sector Lock Capabilities, Bootloader Protection, Security Bit
    - - 32 Fuses, Erased During Chip Erase
    - - User Page For Data To Be Preserved During Chip Erase
- Internal High-Speed SRAM, Single-cycle access at full speed
  - 96KBytes ((AT32UC3B0512, AT32UC3B1512)
  - 32KBytes (AT32UC3B0256, AT32UC3B0128, AT32UC3B1256 and AT32UC3B1128)
  - 16KBytes (AT32UC3B064 and AT32UC3B164)

### 7.2 Physical Memory Map

The system bus is implemented as a bus matrix. All system bus addresses are fixed, and they are never remapped in any way, not even in boot. Note that AVR32 UC CPU uses unsegmented translation, as described in the AVR32UC Technical Architecture Manual. The 32-bit physical address space is mapped as follows:

**Table 7-1.** AT32UC3B Physical Memory Map

Device		Embedded SRAM	Embedded Flash	USB Data	HSB-PB Bridge A	HSB-PB Bridge B
Start Address		0x0000_0000	0x8000_0000	0xD000_0000	0xFFFF_0000	0xFFFE_0000
Size	AT32UC3B0512 AT32UC3B1512	96 Kbytes	512 Kbytes	64 Kbytes	64 Kbytes	64 Kbytes
	AT32UC3B0256 AT32UC3B1256	32 Kbytes	256 Kbytes	64 Kbytes	64 Kbytes	64 Kbytes
	AT32UC3B0128 AT32UC3B1128	32 Kbytes	128 Kbytes	64 Kbytes	64 Kbytes	64 Kbytes
	AT32UC3B064 AT32UC3B164	16 Kbytes	64 Kbytes	64 Kbytes	64 Kbytes	64 Kbytes

## 7.3 Peripheral Address Map

**Table 7-2.** Peripheral Address Mapping

Address		Peripheral Name
0xFFFE0000	USB	USB 2.0 Interface - USB
0xFFFE1000	HMATRIX	HSB Matrix - HMATRIX
0xFFFE1400	HFLASHC	Flash Controller - HFLASHC
0xFFFF0000	PDCA	Peripheral DMA Controller - PDCA
0xFFFF0800	INTC	Interrupt controller - INTC
0xFFFF0C00	PM	Power Manager - PM
0xFFFF0D00	RTC	Real Time Counter - RTC
0xFFFF0D30	WDT	Watchdog Timer - WDT
0xFFFF0D80	EIM	External Interrupt Controller - EIM
0xFFFF1000	GPIO	General Purpose Input/Output Controller - GPIO
0xFFFF1400	USART0	Universal Synchronous/Asynchronous Receiver/Transmitter - USART0
0xFFFF1800	USART1	Universal Synchronous/Asynchronous Receiver/Transmitter - USART1
0xFFFF1C00	USART2	Universal Synchronous/Asynchronous Receiver/Transmitter - USART2
0xFFFF2400	SPI0	Serial Peripheral Interface - SPI0
0xFFFF2C00	TWI	Two-wire Interface - TWI
0xFFFF3000	PWM	Pulse Width Modulation Controller - PWM
0xFFFF3400	SSC	Synchronous Serial Controller - SSC
0xFFFF3800	TC	Timer/Counter - TC



**Table 7-2.** Peripheral Address Mapping

0xFFFF3C00	ADC	Analog to Digital Converter - ADC
0xFFFF4000	ABDAC	Audio Bitstream DAC - ABDAC

## 7.4 CPU Local Bus Mapping

Some of the registers in the GPIO module are mapped onto the CPU local bus, in addition to being mapped on the Peripheral Bus. These registers can therefore be reached both by accesses on the Peripheral Bus, and by accesses on the local bus.

Mapping these registers on the local bus allows cycle-deterministic toggling of GPIO pins since the CPU and GPIO are the only modules connected to this bus. Also, since the local bus runs at CPU speed, one write or read operation can be performed per clock cycle to the local bus-mapped GPIO registers.

The following GPIO registers are mapped on the local bus:

**Table 7-3.** Local bus mapped GPIO registers

Port	Register	Mode	Local Bus Address	Access
0	Output Driver Enable Register (ODER)	WRITE	0x4000_0040	Write-only
		SET	0x4000_0044	Write-only
		CLEAR	0x4000_0048	Write-only
		TOGGLE	0x4000_004C	Write-only
	Output Value Register (OVR)	WRITE	0x4000_0050	Write-only
		SET	0x4000_0054	Write-only
		CLEAR	0x4000_0058	Write-only
		TOGGLE	0x4000_005C	Write-only
Pin Value Register (PVR)	-	0x4000_0060	Read-only	
1	Output Driver Enable Register (ODER)	WRITE	0x4000_0140	Write-only
		SET	0x4000_0144	Write-only
		CLEAR	0x4000_0148	Write-only
		TOGGLE	0x4000_014C	Write-only
	Output Value Register (OVR)	WRITE	0x4000_0150	Write-only
		SET	0x4000_0154	Write-only
		CLEAR	0x4000_0158	Write-only
		TOGGLE	0x4000_015C	Write-only
Pin Value Register (PVR)	-	0x4000_0160	Read-only	

## 8. Boot Sequence

This chapter summarizes the boot sequence of the AT32UC3B. The behaviour after power-up is controlled by the Power Manager. For specific details, refer to section Power Manager (PM).

### 8.1 Starting of clocks

After power-up, the device will be held in a reset state by the Power-On Reset circuitry, until the power has stabilized throughout the device. Once the power has stabilized, the device will use the internal RC Oscillator as clock source.

On system start-up, the PLLs are disabled. All clocks to all modules are running. No clocks have a divided frequency, all parts of the system receives a clock with the same frequency as the internal RC Oscillator.

### 8.2 Fetching of initial instructions

After reset has been released, the AVR32 UC CPU starts fetching instructions from the reset address, which is 0x8000\_0000. This address points to the first address in the internal Flash.

The code read from the internal Flash is free to configure the system to use for example the PLLs, to divide the frequency of the clock routed to some of the peripherals, and to gate the clocks to unused peripherals.

When powering up the device, there may be a delay before the voltage has stabilized, depending on the rise time of the supply used. The CPU can start executing code as soon as the supply is above the POR threshold, and before the supply is stable. Before switching to a high-speed clock source, the user should use the BOD to make sure the VDDCORE is above the minimum level.

## 9. Electrical Characteristics

### 9.1 Absolute Maximum Ratings\*

Operating Temperature.....	-40°C to +85°C
Storage Temperature .....	-60°C to +150°C
Voltage on GPIO Pins with respect to Ground for TCK, RESET_N, PA03, PA04, PA05, PA06, PA07, PA08, PA11, PA12, PA18, PA19, PA28, PA29, PA30, PA31 .....	-0.3 to 3.6V
Voltage on GPIO Pins with respect to Ground except for TCK, RESET_N, PA03, PA04, PA05, PA06, PA07, PA08, PA11, PA12, PA18, PA19, PA28, PA29, PA30, PA31.....	-0.3 to 5.5V
Maximum Operating Voltage (VDDCORE, VDDPLL) .....	1.95V
Maximum Operating Voltage (VDDIO,VDDIN,VDDANA) .	3.6V
Total DC Output Current on all I/O Pin	
for 48-pin package .....	200 mA
for 64-pin package .....	265 mA

\*NOTICE: Stresses beyond those listed under “Absolute Maximum Ratings” may cause permanent damage to the device. This is a stress rating only and functional operation of the device at these or other conditions beyond those indicated in the operational sections of this specification is not implied. Exposure to absolute maximum rating conditions for extended periods may affect device reliability.

## 9.2 DC Characteristics

The following characteristics are applicable to the operating temperature range:  $T_A = -40^{\circ}\text{C}$  to  $85^{\circ}\text{C}$ , unless otherwise specified and are certified for a junction temperature up to  $T_J = 100^{\circ}\text{C}$ .

**Table 9-1.** DC Characteristics

Symbol	Parameter	Conditions	Min.	Typ.	Max.	Unit	
$V_{\text{VDDCORE}}$	DC Supply Core		1.65		1.95	V	
$V_{\text{VDDPLL}}$	DC Supply PLL		1.65		1.95	V	
$V_{\text{VDDIO}}$	DC Supply Peripheral I/Os		3.0		3.6	V	
$V_{\text{IL}}$	Input Low-level Voltage		-0.3		+0.8	V	
$V_{\text{IH}}$	Input High-level Voltage	AT32UC3B064 AT32UC3B0128 AT32UC3B0256 AT32UC3B164 AT32UC3B1128 AT32UC3B1256	All I/O pins except TCK, RESET_N, PA03, PA04, PA05, PA06, PA07, PA08, PA11, PA12, PA18, PA19, PA28, PA29, PA30, PA31	2.0		5.5	V
			TCK, RESET_N, PA03, PA04, PA05, PA06, PA07, PA08, PA11, PA12, PA18, PA19, PA28, PA29, PA30, PA31	2.0		3.6	V
		AT32UC3B0512 AT32UC3B1512	All I/O pins except TCK, RESET_N, PA03, PA04, PA05, PA06, PA07, PA08, PA11, PA12, PA18, PA19, PA28, PA29, PA30, PA31	2.0		5.5	V
			TCK, RESET_N	2.5		3.6	V
			PA03, PA04, PA05, PA06, PA07, PA08, PA11, PA12, PA18, PA19, PA28, PA29, PA30, PA31	2.0		3.6	V
$V_{\text{OL}}$	Output Low-level Voltage	$I_{\text{OL}} = -4\text{mA}$ for all I/O except PA20, PA21, PA22, PA23			0.4	V	
		$I_{\text{OL}} = -8\text{mA}$ for PA20, PA21, PA22, PA23			0.4	V	
$V_{\text{OH}}$	Output High-level Voltage	$I_{\text{OL}} = -4\text{mA}$ for all I/O except PA20, PA21, PA22, PA23	$V_{\text{VDDIO}}$ -0.4			V	
		$I_{\text{OL}} = -8\text{mA}$ for PA20, PA21, PA22, PA23	$V_{\text{VDDIO}}$ -0.4			V	
$I_{\text{OL}}$	Output Low-level Current	All I/O pins except PA20, PA21, PA22, PA23			-4	mA	
		PA20, PA21, PA22, PA23			-8	mA	
$I_{\text{OH}}$	Output High-level Current	All I/O pins except for PA20, PA21, PA22, PA23			4	mA	
		PA20, PA21, PA22, PA23			8	mA	
$I_{\text{LEAK}}$	Input Leakage Current	Pullup resistors disabled			1	$\mu\text{A}$	

**Table 9-1.** DC Characteristics

Symbol	Parameter	Conditions	Min.	Typ.	Max.	Unit		
C <sub>IN</sub>	Input Capacitance	QFP64			7	pF		
		QFP48			7	pF		
		QFN64			7	pF		
		QFN48			7	pF		
R <sub>PULLUP</sub>	Pull-up Resistance	AT32UC3B064 AT32UC3B0128 AT32UC3B0256 AT32UC3B164 AT32UC3B1128 AT32UC3B1256	All I/O pins except RESET_N, TCK, TDI, TMS pins	13	19	25	KΩ	
			RESET_N pin, TCK, TDI, TMS pins	5	12	25	KΩ	
		AT32UC3B0512 AT32UC3B1512	All I/O pins except PA20, PA21, PA22, PA23, RESET_N, TCK, TDI, TMS pins	10	15	20	KΩ	
			PA20, PA21, PA22, PA23	5	7.5	12	KΩ	
			RESET_N pin, TCK, TDI, TMS pins	5	10	25	KΩ	
I <sub>sc</sub>	Static Current	AT32UC3B064 AT32UC3B0128 AT32UC3B0256 AT32UC3B164 AT32UC3B1128 AT32UC3B1256	On V <sub>VDDCORE</sub> = 1.8V, device in static mode	T <sub>A</sub> = 25°C	6		μA	
			All inputs driven including JTAG; RESET_N=1	T <sub>A</sub> = 85°C	42.5		μA	
		AT32UC3B0512 AT32UC3B1512	On V <sub>VDDCORE</sub> = 1.8V, device in static mode	T <sub>A</sub> = 25°C	7.5		μA	
			All inputs driven including JTAG; RESET_N=1	T <sub>A</sub> = 85°C	39		μA	

## 9.3 Regulator Characteristics

**Table 9-2.** Electrical Characteristics

Symbol	Parameter	Conditions	Min.	Typ.	Max.	Unit
V <sub>VDDIN</sub>	Supply voltage (input)		3	3.3	3.6	V
V <sub>VDDOUT</sub>	Supply voltage (output)		1.70	1.8	1.85	V
I <sub>OUT</sub>	Maximum DC output current	V <sub>VDDIN</sub> = 3.3V			100	mA
I <sub>SCR</sub>	Static Current of internal regulator	Low Power mode (stop, deep stop or static) at T <sub>A</sub> = 25°C		10		μA

**Table 9-3.** Decoupling Requirements

Symbol	Parameter	Conditions	Typ.	Technology	Unit
C <sub>IN1</sub>	Input Regulator Capacitor 1		1	NPO	nF
C <sub>IN2</sub>	Input Regulator Capacitor 2		4.7	X7R	μF
C <sub>OUT1</sub>	Output Regulator Capacitor 1		470	NPO	pF
C <sub>OUT2</sub>	Output Regulator Capacitor 2		2.2	X7R	μF

## 9.4 Analog Characteristics

### 9.4.1 ADC Reference

**Table 9-4.** Electrical Characteristics

Symbol	Parameter	Conditions	Min.	Typ.	Max.	Unit
V <sub>ADVREF</sub>	Analog voltage reference (input)		2.6		3.6	V

**Table 9-5.** Decoupling Requirements

Symbol	Parameter	Conditions	Typ.	Technology	Unit
C <sub>VREF1</sub>	Voltage reference Capacitor 1		10	NPO	nF
C <sub>VREF2</sub>	Voltage reference Capacitor 2		1	NPO	uF

### 9.4.2 BOD

**Table 9-6.** BOD Level Values

Symbol	Parameter Value	Conditions	Min.	Typ.	Max.	Unit
BODLEVEL	00 0000b			1.44		V
	01 0111b			1.52		V
	01 1111b			1.61		V
	10 0111b			1.71		V

Table 9-6 describes the values of the BODLEVEL field in the flash FGPFRR register.

**Table 9-7.** BOD Timing

Symbol	Parameter	Conditions	Min.	Typ.	Max.	Unit
$T_{BOD}$	Minimum time with VDDCORE < VBOD to detect power failure	Falling VDDCORE from 1.8V to 1.1V		300	800	ns

### 9.4.3 Reset Sequence

**Table 9-8.** Electrical Characteristics

Symbol	Parameter	Conditions	Min.	Typ.	Max.	Unit
$V_{DDRR}$	VDDCORE rise rate to ensure power-on-reset		2.5			V/ms
$V_{DDFR}$	VDDCORE fall rate to ensure power-on-reset		0.01		400	V/ms
$V_{POR+}$	Rising threshold voltage: voltage up to which device is kept under reset by POR on rising VDDCORE	Rising VDDCORE: $V_{RESTART} \rightarrow V_{POR+}$	1.4	1.55	1.65	V
$V_{POR-}$	Falling threshold voltage: voltage when POR resets device on falling VDDCORE	Falling VDDCORE: $1.8V \rightarrow V_{POR-}$	1.2	1.3	1.4	V
$V_{RESTART}$	On falling VDDCORE, voltage must go down to this value before supply can rise again to ensure reset signal is released at $V_{POR+}$	Falling VDDCORE: $1.8V \rightarrow V_{RESTART}$	-0.1		0.5	V
$T_{POR}$	Minimum time with VDDCORE < $V_{POR-}$	Falling VDDCORE: $1.8V \rightarrow 1.1V$		15		$\mu s$
$T_{RST}$	Time for reset signal to be propagated to system			200	400	$\mu s$
$T_{SSU1}$	Time for Cold System Startup: Time for CPU to fetch its first instruction (RCosc not calibrated)		480		960	$\mu s$
$T_{SSU2}$	Time for Hot System Startup: Time for CPU to fetch its first instruction (RCosc calibrated)			420		$\mu s$

**Figure 9-1.** MCU Cold Start-Up RESET\_N tied to VDDIN

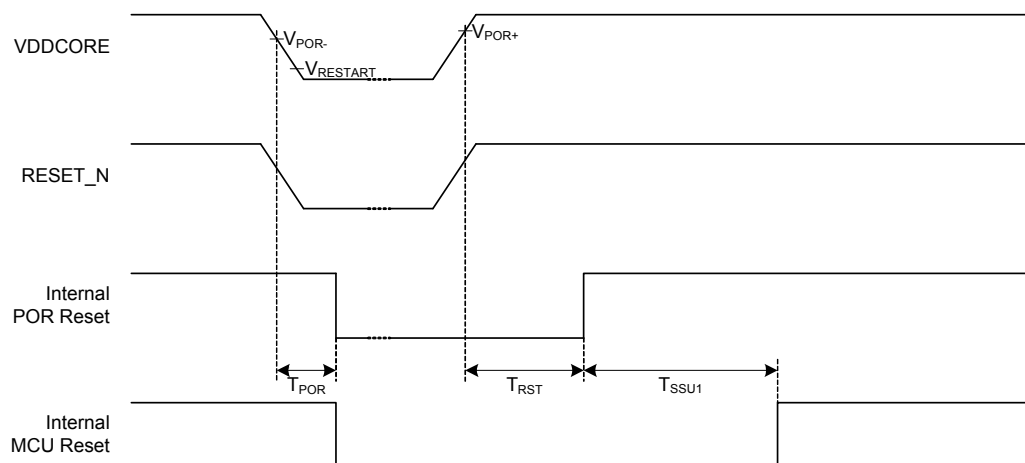

**Figure 9-2.** MCU Cold Start-Up RESET\_N Externally Driven

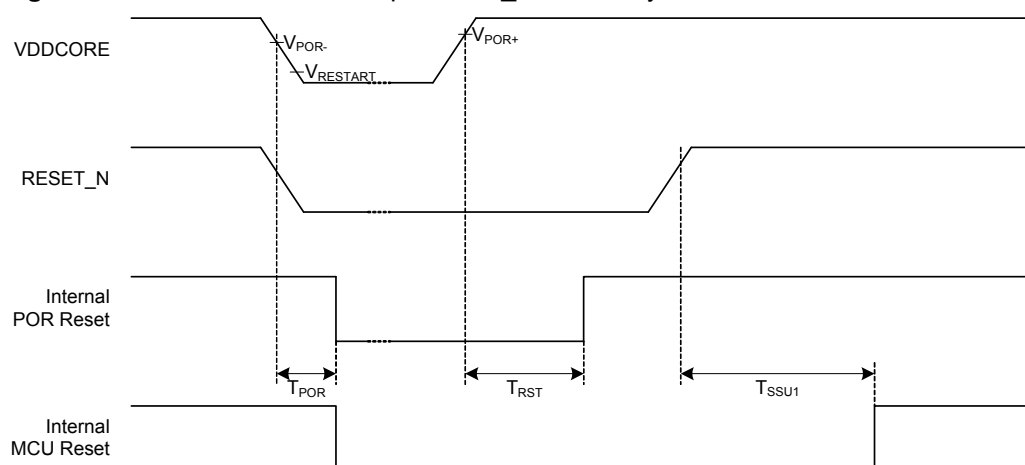

**Figure 9-3.** MCU Hot Start-Up

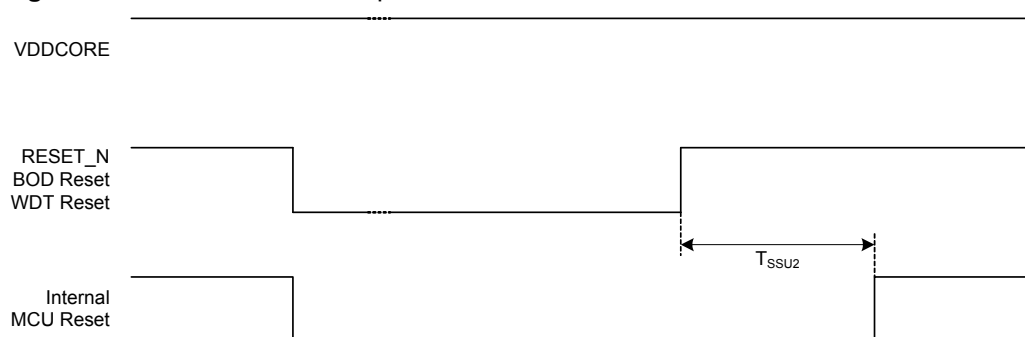

In dual supply configuration, the power up sequence must be carefully managed to ensure a safe startup of the device in all conditions.

The power up sequence must ensure that the internal logic is safely powered when the internal reset (Power On Reset) is released and that the internal Flash logic is safely powered when the CPU fetch the first instructions.



Therefore VDDCORE rise rate (VDDRR) must be equal or superior to 2.5V/ms and VDDIO must reach VDDIO mini value before 500 us ( $< TRST + TSSU1$ ) after VDDCORE has reached  $V_{POR+}$  min value.

**Figure 9-4.** Dual Supply Configuration

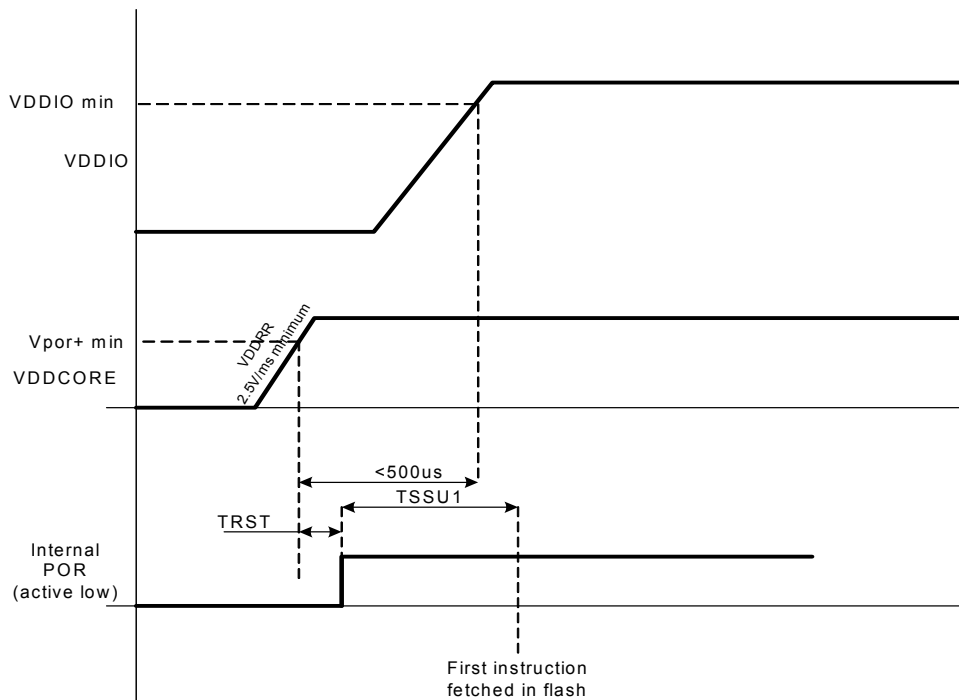

## 9.4.4 RESET\_N Characteristics

**Table 9-9.** RESET\_N Waveform Parameters

Symbol	Parameter	Conditions	Min.	Typ.	Max.	Unit
$t_{RESET}$	RESET_N minimum pulse width		10			ns

## 9.5 Power Consumption

The values in [Table 9-10](#), [Table 9-11 on page 43](#) and [Table 9-12 on page 44](#) are measured values of power consumption with operating conditions as follows:

- $V_{DDIO} = V_{DDANA} = 3.3V$
- $V_{DDCORE} = V_{DDPLL} = 1.8V$
- $T_A = 25^{\circ}C$ ,  $T_A = 85^{\circ}C$
- I/Os are configured in input, pull-up enabled.

**Figure 9-5.** Measurement Setup

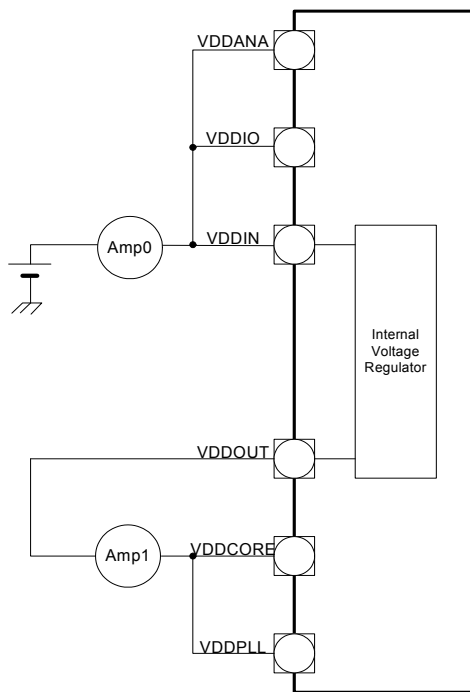

The following tables represent the power consumption measured on the power supplies.

## 9.5.1 Power Consumption for Different Sleep Modes

**Table 9-10.** Power Consumption for Different Sleep Modes for AT32UC3B064, AT32UC3B0128, AT32UC3B0256, AT32UC3B164, AT32UC3B1128, AT32UC3B1256

Mode	Conditions	Typ.	Unit	
Active	- CPU running a recursive Fibonacci Algorithm from flash and clocked from PLL0 at f MHz. - Voltage regulator is on. - XIN0: external clock. Xin1 Stopped. XIN32 stopped. - All peripheral clocks activated with a division by 8. - GPIOs are inactive with internal pull-up, JTAG unconnected with external pull-up and Input pins are connected to GND	$0.3xf(\text{MHz})+0.443$	mA/MHz	
	Same conditions at 60 MHz	18.5	mA	
Idle	See Active mode conditions	$0.117xf(\text{MHz})+0.28$	mA/MHz	
	Same conditions at 60 MHz	7.3	mA	
Frozen	See Active mode conditions	$0.058xf(\text{MHz})+0.115$	mA/MHz	
	Same conditions at 60 MHz	3.6	mA	
Standby	See Active mode conditions	$0.042xf(\text{MHz})+0.115$	mA/MHz	
	Same conditions at 60 MHz	2.7	mA	
Stop	- CPU running in sleep mode - XIN0, Xin1 and XIN32 are stopped. - All peripheral clocks are deactivated. - GPIOs are inactive with internal pull-up, JTAG unconnected with external pull-up and Input pins are connected to GND.	37.8	$\mu\text{A}$	
Deepstop	See Stop mode conditions	24.9	$\mu\text{A}$	
Static	See Stop mode conditions	Voltage Regulator On	13.9	$\mu\text{A}$
		Voltage Regulator Off	8.9	$\mu\text{A}$

Notes: 1. Core frequency is generated from XIN0 using the PLL so that  $140 \text{ MHz} < f_{\text{PLL0}} < 160 \text{ MHz}$  and  $10 \text{ MHz} < f_{\text{XIN0}} < 12 \text{ MHz}$ .

**Table 9-11.** Power Consumption for Different Sleep Modes for AT32UC3B0512, AT32UC3B1512

Mode	Conditions	Typ.	Unit
Active	- CPU running a recursive Fibonacci Algorithm from flash and clocked from PLL0 at f MHz. - Voltage regulator is on. - XIN0: external clock. Xin1 Stopped. XIN32 stopped. - All peripheral clocks activated with a division by 8. - GPIOs are inactive with internal pull-up, JTAG unconnected with external pull-up and Input pins are connected to GND	$0.359xf(\text{MHz})+1.53$	mA/MHz
	Same conditions at 60 MHz	24	mA
Idle	See Active mode conditions	$0.146xf(\text{MHz})+0.291$	mA/MHz
	Same conditions at 60 MHz	9	mA

**Table 9-11.** Power Consumption for Different Sleep Modes for AT32UC3B0512, AT32UC3B1512

Mode	Conditions	Typ.	Unit
Frozen	See Active mode conditions	$0.0723 \times f(\text{MHz}) + 0.156$	mA/MHz
	Same conditions at 60 MHz	4.5	mA
Standby	See Active mode conditions	$0.0537 \times f(\text{MHz}) + 0.166$	mA/MHz
	Same conditions at 60 MHz	3.4	mA
Stop	<ul style="list-style-type: none"> <li>- CPU running in sleep mode</li> <li>- XIN0, Xin1 and XIN32 are stopped.</li> <li>- All peripheral clocks are desactivated.</li> <li>- GPIOs are inactive with internal pull-up, JTAG unconnected with external pull-up and Input pins are connected to GND.</li> </ul>	62	μA
Deepstop	See Stop mode conditions	30	μA
Static	See Stop mode conditions	Voltage Regulator On	15.5
		Voltage Regulator Off	7.5

Notes: 1. Core frequency is generated from XIN0 using the PLL so that  $140 \text{ MHz} < f_{\text{PLL0}} < 160 \text{ MHz}$  and  $10 \text{ MHz} < f_{\text{XIN0}} < 12 \text{ MHz}$ .

**Table 9-12.** Peripheral Interface Power Consumption in Active Mode

Peripheral	Conditions	Consumption	Unit
INTC	AT32UC3B064 AT32UC3B0128 AT32UC3B0256 AT32UC3B164 AT32UC3B1128 AT32UC3B1256 AT32UC3B0512 AT32UC3B1512	20	μA/MHz
GPIO		16	
PDCA		12	
USART		14	
USB		23	
ADC		8	
TWI		7	
PWM		18	
SPI		8	
SSC		11	
TC		11	
ABDAC		6	

## 9.6 System Clock Characteristics

These parameters are given in the following conditions:

- $V_{DDCORE} = 1.8V$
- Ambient Temperature = 25°C

### 9.6.1 CPU/HSB Clock Characteristics

**Table 9-13.** Core Clock Waveform Parameters

Symbol	Parameter	Conditions	Min.	Typ.	Max.	Unit
$1/(t_{CPCPU})$	CPU Clock Frequency				60	MHz
$t_{CPCPU}$	CPU Clock Period		16.6			ns

### 9.6.2 PBA Clock Characteristics

**Table 9-14.** PBA Clock Waveform Parameters

Symbol	Parameter	Conditions	Min.	Typ.	Max.	Unit
$1/(t_{CPPBA})$	PBA Clock Frequency				60	MHz
$t_{CPPBA}$	PBA Clock Period		16.6			ns

### 9.6.3 PBB Clock Characteristics

**Table 9-15.** PBB Clock Waveform Parameters

Symbol	Parameter	Conditions	Min.	Typ.	Max.	Unit
$1/(t_{CPPBB})$	PBB Clock Frequency				60	MHz
$t_{CPPBB}$	PBB Clock Period		16.6			ns

## 9.7 Oscillator Characteristics

The following characteristics are applicable to the operating temperature range:  $T_A = -40^{\circ}\text{C}$  to  $85^{\circ}\text{C}$  and worst case of power supply, unless otherwise specified.

### 9.7.1 Slow Clock RC Oscillator

**Table 9-16.** RC Oscillator Frequency

Symbol	Parameter	Conditions	Min.	Typ.	Max.	Unit
$F_{RC}$	RC Oscillator Frequency	Calibration point: $T_A = 85^{\circ}\text{C}$		115.2	116	KHz
		$T_A = 25^{\circ}\text{C}$		112		KHz
		$T_A = -40^{\circ}\text{C}$	105	108		KHz

### 9.7.2 32 KHz Oscillator

**Table 9-17.** 32 KHz Oscillator Characteristics

Symbol	Parameter	Conditions	Min.	Typ.	Max.	Unit
$1/(t_{CP32KHz})$	Oscillator Frequency	External clock on XIN32			30	MHz
		Crystal		32 768		Hz
$C_L$	Equivalent Load Capacitance		6		12.5	pF
ESR	Crystal Equivalent Series Resistance				100	K $\Omega$
$t_{ST}$	Startup Time	$C_L = 6\text{pF}^{(1)}$ $C_L = 12.5\text{pF}^{(1)}$			600 1200	ms
$t_{CH}$	XIN32 Clock High Half-period		$0.4 t_{CP}$		$0.6 t_{CP}$	
$t_{CL}$	XIN32 Clock Low Half-period		$0.4 t_{CP}$		$0.6 t_{CP}$	
$C_{IN}$	XIN32 Input Capacitance				5	pF
$I_{OSC}$	Current Consumption	Active mode			1.8	$\mu\text{A}$
		Standby mode			0.1	$\mu\text{A}$

Note: 1.  $C_L$  is the equivalent load capacitance.

## 9.7.3 Main Oscillators

**Table 9-18.** Main Oscillators Characteristics

Symbol	Parameter	Conditions	Min.	Typ.	Max.	Unit
$1/(t_{CPMAIN})$	Oscillator Frequency	External clock on XIN			50	MHz
		Crystal	0.4		20	MHz
$C_{L1}, C_{L2}$	Internal Load Capacitance ( $C_{L1} = C_{L2}$ )			7		pF
ESR	Crystal Equivalent Series Resistance				75	$\Omega$
	Duty Cycle		40	50	60	%
$t_{ST}$	Startup Time	f = 400 KHz f = 8 MHz f = 16 MHz f = 20 MHz			25 4 1.4 1	ms
$t_{CH}$	XIN Clock High Half-period		$0.4 t_{CP}$		$0.6 t_{CP}$	
$t_{CL}$	XIN Clock Low Half-period		$0.4 t_{CP}$		$0.6 t_{CP}$	
$C_{IN}$	XIN Input Capacitance			7		pF
$I_{OSC}$	Current Consumption	Active mode at 400 KHz. Gain = G0 Active mode at 8 MHz. Gain = G1 Active mode at 16 MHz. Gain = G2 Active mode at 20 MHz. Gain = G3		30 45 95 205		$\mu A$

## 9.7.4 Phase Lock Loop

**Table 9-19.** Phase Lock Loop Characteristics

Symbol	Parameter	Conditions	Min.	Typ.	Max.	Unit
$F_{OUT}$	VCO Output Frequency		80		240	MHz
$F_{IN}$	Input Frequency		4		16	MHz
$I_{PLL}$	Current Consumption	Active mode $F_{VCO}@96$ MHz Active mode $F_{VCO}@128$ MHz Active mode $F_{VCO}@160$ MHz		320 410 450		$\mu A$
		Standby mode		5		$\mu A$

## 9.8 ADC Characteristics

**Table 9-20.** Channel Conversion Time and ADC Clock

Parameter	Conditions	Min.	Typ.	Max.	Unit
ADC Clock Frequency	10-bit resolution mode			5	MHz
ADC Clock Frequency	8-bit resolution mode			8	MHz
Startup Time	Return from Idle Mode			20	μs
Track and Hold Acquisition Time		600			ns
Track and Hold Input Resistor			350		Ω
Track and Hold Capacitor			12		pF
Conversion Time	ADC Clock = 5 MHz			2	μs
	ADC Clock = 8 MHz			1.25	μs
Throughput Rate	ADC Clock = 5 MHz			384 <sup>(1)</sup>	kSPS
	ADC Clock = 8 MHz			533 <sup>(2)</sup>	kSPS

Notes: 1. Corresponds to 13 clock cycles: 3 clock cycles for track and hold acquisition time and 10 clock cycles for conversion.  
 2. Corresponds to 15 clock cycles: 5 clock cycles for track and hold acquisition time and 10 clock cycles for conversion.

**Table 9-21.** External Voltage Reference Input

Parameter	Conditions	Min.	Typ.	Max.	Unit
ADVREF Input Voltage Range	<sup>(1)</sup>	2.6		VDDANA	V
ADVREF Average Current	On 13 samples with ADC Clock = 5 MHz		200	250	μA
Current Consumption on VDDANA	On 13 samples with ADC Clock = 5 MHz			1	mA

Note: 1. ADVREF should be connected to GND to avoid extra consumption in case ADC is not used.

**Table 9-22.** Analog Inputs

Parameter	Conditions	Min.	Typ.	Max.	Unit
Input Voltage Range		0		V <sub>ADVREF</sub>	V
Input Leakage Current				1	μA
Input Capacitance			7		pF

**Table 9-23.** Transfer Characteristics in 8-bit Mode

Parameter	Conditions	Min.	Typ.	Max.	Unit
Resolution			8		Bit
Absolute Accuracy	ADC Clock = 5 MHz			0.8	LSB
	ADC Clock = 8 MHz			1.5	LSB
Integral Non-linearity	ADC Clock = 5 MHz		0.35	0.5	LSB
	ADC Clock = 8 MHz		0.5	1.0	LSB



**Table 9-23.** Transfer Characteristics in 8-bit Mode

Parameter	Conditions	Min.	Typ.	Max.	Unit
Differential Non-linearity	ADC Clock = 5 MHz		0.3	0.5	LSB
	ADC Clock = 8 MHz		0.5	1.0	LSB
Offset Error	ADC Clock = 5 MHz	-0.5		0.5	LSB
Gain Error	ADC Clock = 5 MHz	-0.5		0.5	LSB

**Table 9-24.** Transfer Characteristics in 10-bit Mode

Parameter	Conditions	Min.	Typ.	Max.	Unit
Resolution			10		Bit
Absolute Accuracy	ADC Clock = 5 MHz			3	LSB
Integral Non-linearity	ADC Clock = 5 MHz		1.5	2	LSB
Differential Non-linearity	ADC Clock = 5 MHz		1	2	LSB
	ADC Clock = 2.5 MHz		0.6	1	LSB
Offset Error	ADC Clock = 5 MHz	-2		2	LSB
Gain Error	ADC Clock = 5MHz	-2		2	LSB

## 9.9 USB Transceiver Characteristics

### 9.9.1 Electrical Characteristics

**Table 9-25.** Electrical Parameters

Symbol	Parameter	Conditions	Min.	Typ.	Max.	Unit
R <sub>EXT</sub>	Recommended external USB series resistor	In series with each USB pin with ±5%		39		Ω

The USB on-chip buffers comply with the Universal Serial Bus (USB) v2.0 standard. All AC parameters related to these buffers can be found within the USB 2.0 electrical specifications.

## 9.10 JTAG Characteristics

### 9.10.1 JTAG Timing

Figure 9-6. JTAG Interface Signals

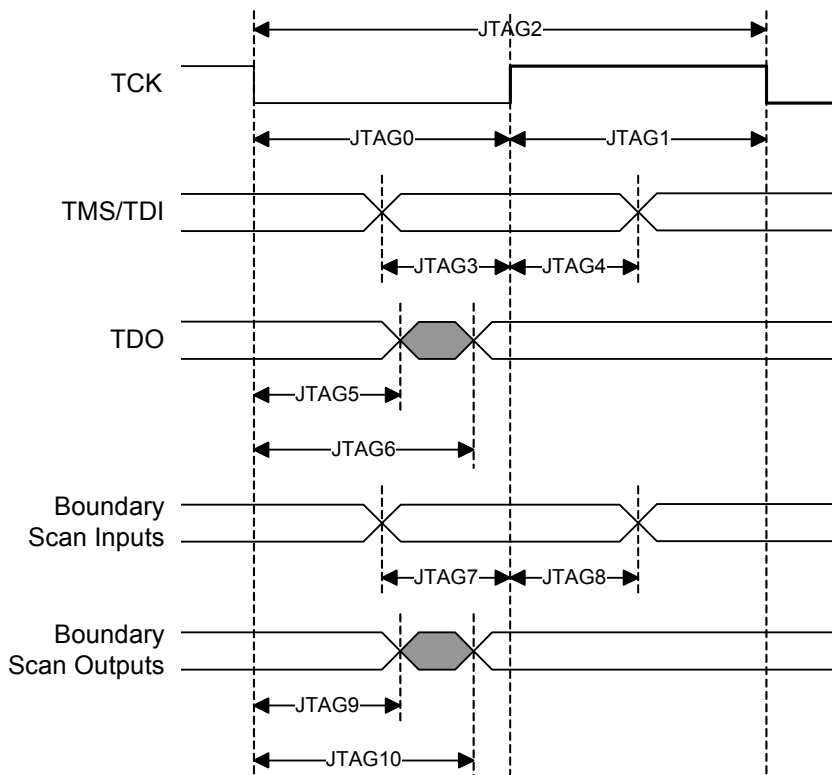

Table 9-26. JTAG Timings<sup>(1)</sup>

Symbol	Parameter	Conditions	Min	Max	Units
JTAG0	TCK Low Half-period	V <sub>VDDIO</sub> from 3.0V to 3.6V, maximum external capacitor = 40pF	23.2		ns
JTAG1	TCK High Half-period		8.8		ns
JTAG2	TCK Period		32.0		ns
JTAG3	TDI, TMS Setup before TCK High		3.9		ns
JTAG4	TDI, TMS Hold after TCK High		0.6		ns
JTAG5	TDO Hold Time		4.5		ns
JTAG6	TCK Low to TDO Valid			23.2	ns
JTAG7	Boundary Scan Inputs Setup Time		0		ns
JTAG8	Boundary Scan Inputs Hold Time		5.0		ns
JTAG9	Boundary Scan Outputs Hold Time		8.7		ns
JTAG10	TCK to Boundary Scan Outputs Valid		17.7	ns	

Note: 1. These values are based on simulation and characterization of other AVR microcontrollers manufactured in the same pro-cess technology. These values are not covered by test limits in production.

9.11 SPI Characteristics

**Figure 9-7.** SPI Master mode with (CPOL = NCPHA = 0) or (CPOL= NCPHA= 1)

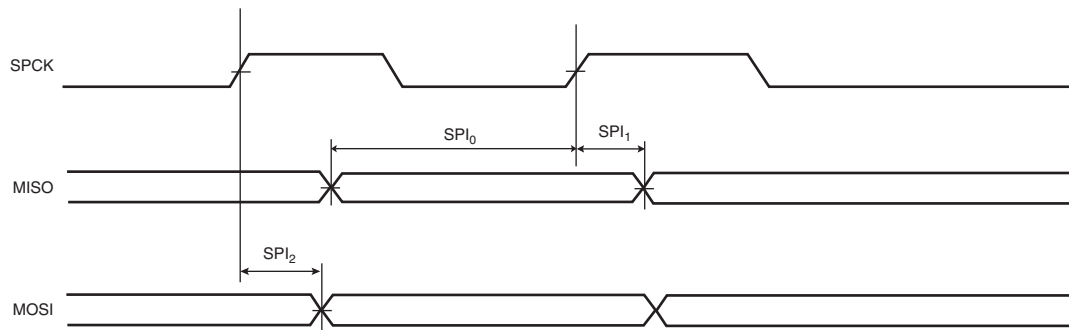

**Figure 9-8.** SPI Master mode with (CPOL=0 and NCPHA=1) or (CPOL=1 and NCPHA=0)

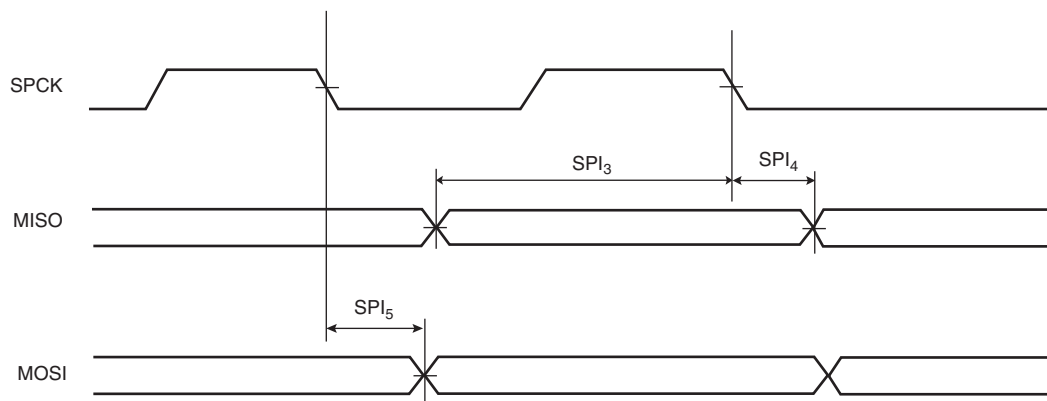

**Figure 9-9.** SPI Slave mode with (CPOL=0 and NCPHA=1) or (CPOL=1 and NCPHA=0)

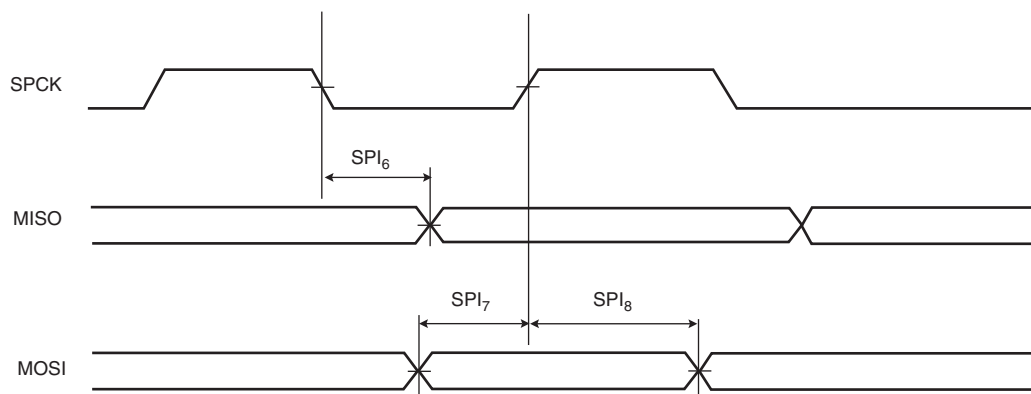

**Figure 9-10.** SPI Slave mode with (CPOL = NCPHA = 0) or (CPOL= NCPHA= 1)

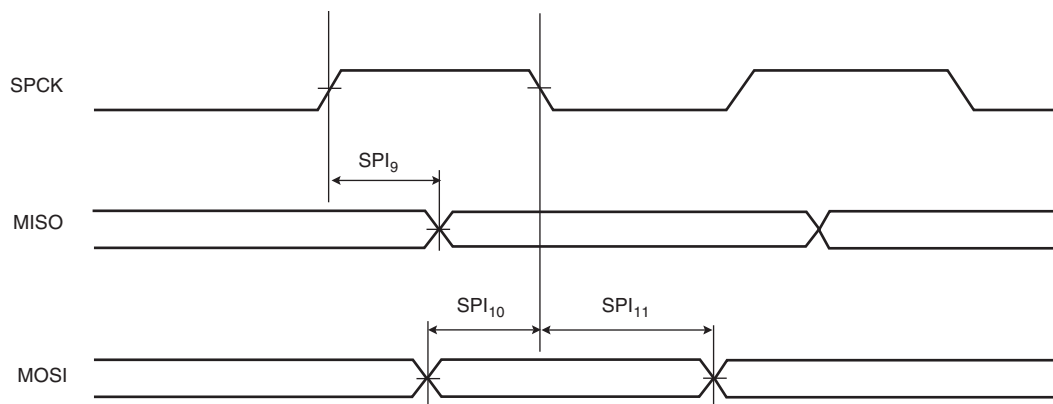

**Table 9-27.** SPI Timings

Symbol	Parameter	Conditions	Min.	Max.	Unit
SPI <sub>0</sub>	MISO Setup time before SPCK rises (master)	3.3V domain <sup>(1)</sup>	22 + (t <sub>CPMCK</sub> )/2 <sup>(2)</sup>		ns
SPI <sub>1</sub>	MISO Hold time after SPCK rises (master)	3.3V domain <sup>(1)</sup>	0		ns
SPI <sub>2</sub>	SPCK rising to MOSI Delay (master)	3.3V domain <sup>(1)</sup>		7	ns
SPI <sub>3</sub>	MISO Setup time before SPCK falls (master)	3.3V domain <sup>(1)</sup>	22 + (t <sub>CPMCK</sub> )/2 <sup>(2)</sup>		ns
SPI <sub>4</sub>	MISO Hold time after SPCK falls (master)	3.3V domain <sup>(1)</sup>	0		ns
SPI <sub>5</sub>	SPCK falling to MOSI Delay (master)	3.3V domain <sup>(1)</sup>		7	ns
SPI <sub>6</sub>	SPCK falling to MISO Delay (slave)	3.3V domain <sup>(1)</sup>		26.5	ns
SPI <sub>7</sub>	MOSI Setup time before SPCK rises (slave)	3.3V domain <sup>(1)</sup>	0		ns
SPI <sub>8</sub>	MOSI Hold time after SPCK rises (slave)	3.3V domain <sup>(1)</sup>	1.5		ns
SPI <sub>9</sub>	SPCK rising to MISO Delay (slave)	3.3V domain <sup>(1)</sup>		27	ns
SPI <sub>10</sub>	MOSI Setup time before SPCK falls (slave)	3.3V domain <sup>(1)</sup>	0		ns
SPI <sub>11</sub>	MOSI Hold time after SPCK falls (slave)	3.3V domain <sup>(1)</sup>	1		ns

- Notes: 1. 3.3V domain: V<sub>VDDIO</sub> from 3.0V to 3.6V, maximum external capacitor = 40 pF.  
 2. t<sub>CPMCK</sub>: Master Clock period in ns.

## 9.12 Flash Memory Characteristics

The following table gives the device maximum operating frequency depending on the field FWS of the Flash FSR register. This field defines the number of wait states required to access the Flash Memory. Flash operating frequency equals the CPU/HSB frequency.

**Table 9-28.** Flash Operating Frequency

Symbol	Parameter	Conditions	Min.	Typ.	Max.	Unit
F <sub>FOP</sub>	Flash Operating Frequency	FWS = 0			33	MHz
		FWS = 1			60	MHz

**Table 9-29.** Programming Time

Symbol	Parameter	Conditions	Min.	Typ.	Max.	Unit
T <sub>FPP</sub>	Page Programming Time			4		ms
T <sub>FFP</sub>	Fuse Programming Time			0.5		ms
T <sub>FCE</sub>	Chip Erase Time			4		ms

**Table 9-30.** Flash Parameters

Symbol	Parameter	Conditions	Min.	Typ.	Max.	Unit
N <sub>FARRAY</sub>	Flash Array Write/Erase cycle				100K	Cycle
N <sub>FFUSE</sub>	General Purpose Fuses write cycle				1000	Cycle
T <sub>FDR</sub>	Flash Data Retention Time			15		Year

## 10. Mechanical Characteristics

### 10.1 Thermal Considerations

#### 10.1.1 Thermal Data

Table 10-1 summarizes the thermal resistance data depending on the package.

**Table 10-1.** Thermal Resistance Data

Symbol	Parameter	Condition	Package	Typ	Unit
$\theta_{JA}$	Junction-to-ambient thermal resistance	Still Air	TQFP64	49.6	°C/W
$\theta_{JC}$	Junction-to-case thermal resistance		TQFP64	13.5	
$\theta_{JA}$	Junction-to-ambient thermal resistance	Still Air	TQFP48	51.1	°C/W
$\theta_{JC}$	Junction-to-case thermal resistance		TQFP48	13.7	

#### 10.1.2 Junction Temperature

The average chip-junction temperature,  $T_J$ , in °C can be obtained from the following:

1.  $T_J = T_A + (P_D \times \theta_{JA})$
2.  $T_J = T_A + (P_D \times (\theta_{HEATSINK} + \theta_{JC}))$

where:

- $\theta_{JA}$  = package thermal resistance, Junction-to-ambient (°C/W), provided in [Table 10-1 on page 55](#).
- $\theta_{JC}$  = package thermal resistance, Junction-to-case thermal resistance (°C/W), provided in [Table 10-1 on page 55](#).
- $\theta_{HEAT\ SINK}$  = cooling device thermal resistance (°C/W), provided in the device datasheet.
- $P_D$  = device power consumption (W) estimated from data provided in the section "[Power Consumption](#)" on page 42.
- $T_A$  = ambient temperature (°C).

From the first equation, the user can derive the estimated lifetime of the chip and decide if a cooling device is necessary or not. If a cooling device is to be fitted on the chip, the second equation should be used to compute the resulting average chip-junction temperature  $T_J$  in °C.

## 10.2 Package Drawings

Figure 10-1. TQFP-64 package drawing

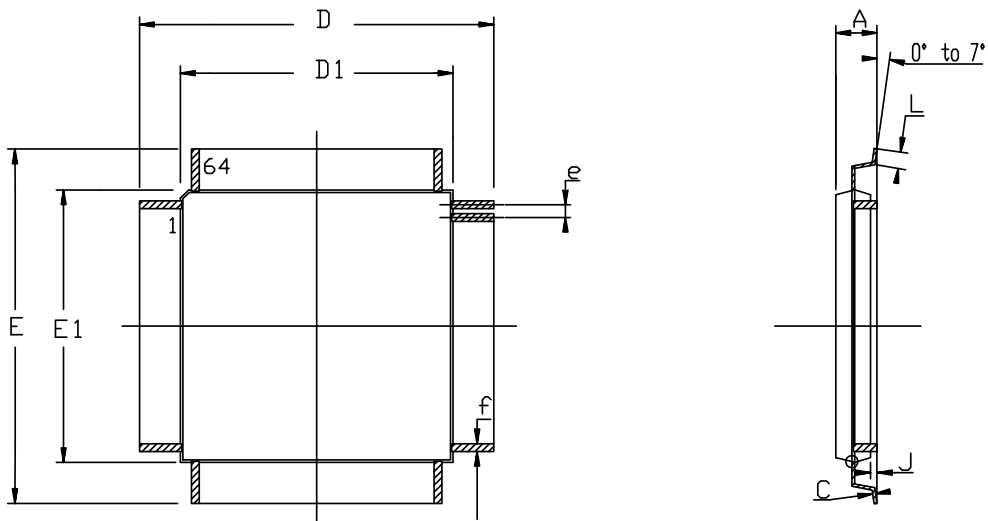

COMMON DIMENSIONS IN MM

SYMBOL	Min	Max	NOTES
A	----	1.20	
A1	0.95	1.05	
C	0.09	0.20	
D	12.00 BSC		
D1	10.00 BSC		
E	12.00 BSC		
E1	10.00 BSC		
J	0.05	0.15	
L	0.45	0.75	
e	0.50 BSC		
f	0.17	0.27	

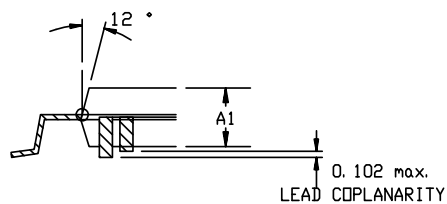

Table 10-2. Device and Package Maximum Weight

Weight	300 mg
--------	--------

Table 10-3. Package Characteristics

Moisture Sensitivity Level	Jedec J-STD-20D-MSL3
----------------------------	----------------------

Table 10-4. Package Reference

JEDEC Drawing Reference	MS-026
JESD97 Classification	e3



**Figure 10-2.** TQFP-48 package drawing

DRAWINGS NOT SCALED

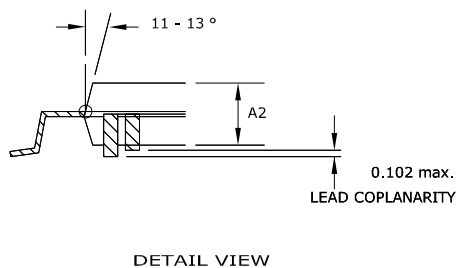
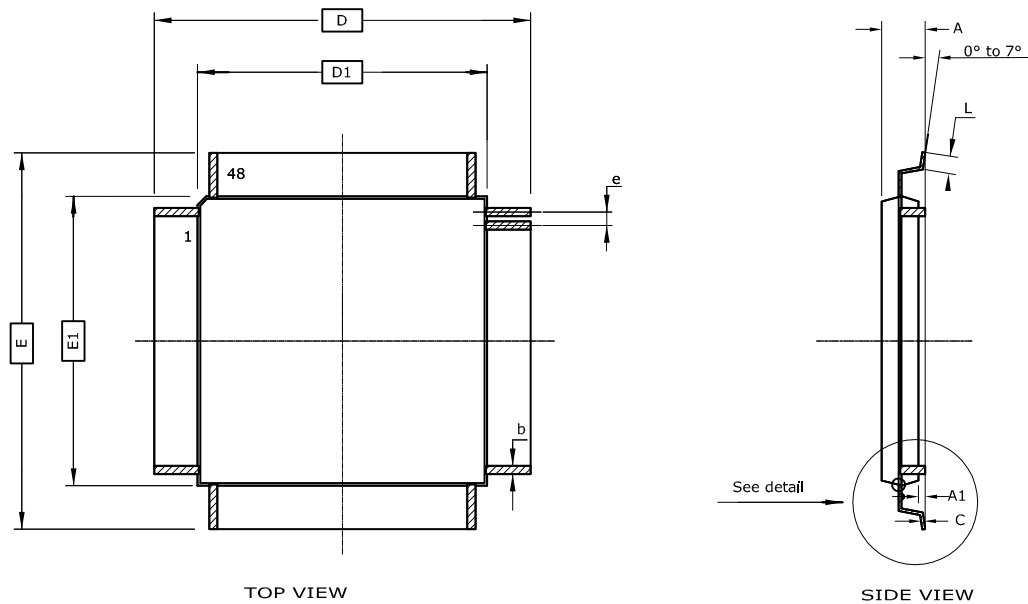

COMMON DIMENSIONS  
(Unit of Measure = mm)

SYMBOL	MIN	NOM	MAX	NOTE
A	-----	-----	1.20	
A1	0.05	-----	0.15	
A2	0.95	-----	1.05	
C	0.09	-----	0.20	
D/E	9.00 BSC			
D1/E1	7.00 BSC			
L	0.45	-----	0.75	
b	0.17	-----	0.27	
e	0.50 BSC			

- Notes :
1. This drawing is for general information only. Refer to JEDEC Drawing MS-026, Variation ABC.
  2. Dimensions D1 and E1 do not include mold protrusion. Allowable protrusion is 0.25mm per side. Dimensions D1 and E1 are maximum plastic body size dimensions including mold mismatch.
  3. Lead coplanarity is 0.10mm maximum.

**Table 10-5.** Device and Package Maximum Weight

Weight	100 mg
--------	--------

**Table 10-6.** Package Characteristics

Moisture Sensitivity Level	Jedec J-STD-20D-MSL3
----------------------------	----------------------

**Table 10-7.** Package Reference

JEDEC Drawing Reference	MS-026
JESD97 Classification	e3

Figure 10-3. QFN-64 package drawing

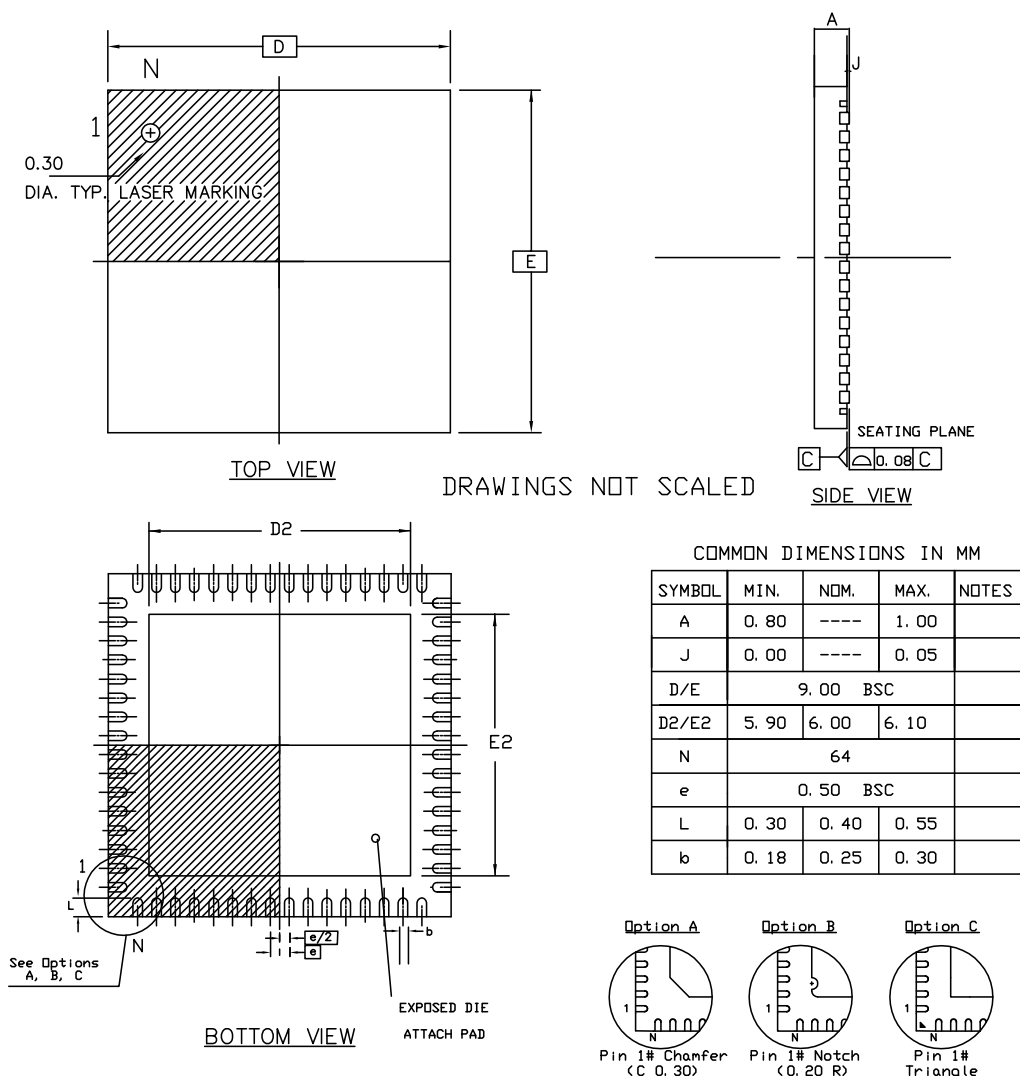

Compliant JEDEC Standard M0-220 variation VMMD-3

Table 10-8. Device and Package Maximum Weight

Weight	200 mg
--------	--------

Table 10-9. Package Characteristics

Moisture Sensitivity Level	Jedec J-STD-20D-MSL3
----------------------------	----------------------

Table 10-10. Package Reference

JEDEC Drawing Reference	M0-220
JESD97 Classification	e3



### 10.3 Soldering Profile

Table 10-14 gives the recommended soldering profile from J-STD-20.

**Table 10-14.** Soldering Profile

Profile Feature	Green Package
Average Ramp-up Rate (217°C to Peak)	3°C/s
Preheat Temperature 175°C ±25°C	Min. 150°C, Max. 200°C
Temperature Maintained Above 217°C	60-150s
Time within 5-C of Actual Peak Temperature	30s
Peak Temperature Range	260°C
Ramp-down Rate	6°C/s
Time 25-C to Peak Temperature	Max. 8mn

Note: It is recommended to apply a soldering temperature higher than 250°C. A maximum of three reflow passes is allowed per component.

## 11. Ordering Information

Device	Ordering Code	Package	Conditioning	Temperature Operating Range
<b>AT32UC3B0512</b>	AT32UC3B0512-A2UES	TQFP 64	-	Industrial (-40°C to 85°C)
	AT32UC3B0512-A2UR	TQFP 64	Reel	Industrial (-40°C to 85°C)
	AT32UC3B0512-A2UT	TQFP 64	Tray	Industrial (-40°C to 85°C)
	AT32UC3B0512-Z2UES	QFN 64	-	Industrial (-40°C to 85°C)
	AT32UC3B0512-Z2UR	QFN 64	Reel	Industrial (-40°C to 85°C)
	AT32UC3B0512-Z2UT	QFN 64	Tray	Industrial (-40°C to 85°C)
<b>AT32UC3B0256</b>	AT32UC3B0256-A2UT	TQFP 64	Tray	Industrial (-40°C to 85°C)
	AT32UC3B0256-A2UR	TQFP 64	Reel	Industrial (-40°C to 85°C)
	AT32UC3B0256-Z2UT	QFN 64	Tray	Industrial (-40°C to 85°C)
	AT32UC3B0256-Z2UR	QFN 64	Reel	Industrial (-40°C to 85°C)
<b>AT32UC3B0128</b>	AT32UC3B0128-A2UT	TQFP 64	Tray	Industrial (-40°C to 85°C)
	AT32UC3B0128-A2UR	TQFP 64	Reel	Industrial (-40°C to 85°C)
	AT32UC3B0128-Z2UT	QFN 64	Tray	Industrial (-40°C to 85°C)
	AT32UC3B0128-Z2UR	QFN 64	Reel	Industrial (-40°C to 85°C)
<b>AT32UC3B064</b>	AT32UC3B064-A2UT	TQFP 64	Tray	Industrial (-40°C to 85°C)
	AT32UC3B064-A2UR	TQFP 64	Reel	Industrial (-40°C to 85°C)
	AT32UC3B064-Z2UT	QFN 64	Tray	Industrial (-40°C to 85°C)
	AT32UC3B064-Z2UR	QFN 64	Reel	Industrial (-40°C to 85°C)
<b>AT32UC3B1512</b>	AT32UC3B1512-Z1UT	QFN 48	-	Industrial (-40°C to 85°C)
	AT32UC3B1512-Z1UR	QFN 48	-	Industrial (-40°C to 85°C)
<b>AT32UC3B1256</b>	AT32UC3B1256-AUT	TQFP 48	Tray	Industrial (-40°C to 85°C)
	AT32UC3B1256-AUR	TQFP 48	Reel	Industrial (-40°C to 85°C)
	AT32UC3B1256-Z1UT	QFN 48	Tray	Industrial (-40°C to 85°C)
	AT32UC3B1256-Z1UR	QFN 48	Reel	Industrial (-40°C to 85°C)
<b>AT32UC3B1128</b>	AT32UC3B1128-AUT	TQFP 48	Tray	Industrial (-40°C to 85°C)
	AT32UC3B1128-AUR	TQFP 48	Reel	Industrial (-40°C to 85°C)
	AT32UC3B1128-Z1UT	QFN 48	Tray	Industrial (-40°C to 85°C)
	AT32UC3B1128-Z1UR	QFN 48	Reel	Industrial (-40°C to 85°C)
<b>AT32UC3B164</b>	AT32UC3B164-AUT	TQFP 48	Tray	Industrial (-40°C to 85°C)
	AT32UC3B164-AUR	TQFP 48	Reel	Industrial (-40°C to 85°C)
	AT32UC3B164-Z1UT	QFN 48	Tray	Industrial (-40°C to 85°C)
	AT32UC3B164-Z1UR	QFN 48	Reel	Industrial (-40°C to 85°C)

## 12. Errata

### 12.1 AT32UC3B0512, AT32UC3B1512

#### 12.1.1 Rev D

- PWM

1. **PWM channel interrupt enabling triggers an interrupt**  
 When enabling a PWM channel that is configured with center aligned period (CALG=1), an interrupt is signalled.  
**Fix/Workaround**  
 When using center aligned mode, enable the channel and read the status before channel interrupt is enabled.
2. **PWN counter restarts at 0x0001**  
 The PWM counter restarts at 0x0001 and not 0x0000 as specified. Because of this the first PWM period has one more clock cycle.  
**Fix/Workaround**  
 - The first period is 0x0000, 0x0001, ..., period.  
 - Consecutive periods are 0x0001, 0x0002, ..., period.
3. **PWM update period to a 0 value does not work**  
 It is impossible to update a period equal to 0 by the using the PWM update register (PWM\_CUPD).  
**Fix/Workaround**  
 Do not update the PWM\_CUPD register with a value equal to 0.
4. **SPI**
5. **SPI Slave / PDCA transfer: no TX UNDERRUN flag**  
 There is no TX UNDERRUN flag available, therefore in SPI slave mode, there is no way to be informed of a character lost in transmission.  
**Fix/Workaround**  
 For PDCA transfer: none.
6. **SPI bad serial clock generation on 2nd chip\_select when SCBR=1, CPOL=1, and NCPHA=0**  
 When multiple chip selects (CS) are in use, if one of the baudrates equal 1 while one (CSRn.SCBR=1) of the others do not equal 1, and CSRn.CPOL=1 and CSRn.NCPHA=0, then an additional pulse will be generated on SCK.  
**Fix/Workaround**  
 When multiple CS are in use, if one of the baudrates equals 1, the others must also equal 1 if CSRn.CPOL=1 and CSRn.NCPHA=0.

**7. SPI Glitch on RXREADY flag in slave mode when enabling the SPI or during the first transfer**

In slave mode, the SPI can generate a false RXREADY signal during enabling of the SPI or during the first transfer.

**Fix/Workaround**

1. Set slave mode, set required CPOL/CPHA.
2. Enable SPI.
3. Set the polarity CPOL of the line in the opposite value of the required one.
4. Set the polarity CPOL to the required one.
5. Read the RXHOLDING register.

Transfers can now begin and RXREADY will now behave as expected.

**8. SPI disable does not work in SLAVE mode**

SPI disable does not work in SLAVE mode.

**Fix/Workaround**

Read the last received data, then perform a software reset by writing a one to the Software Reset bit in the Control Register (CR.SWRST).

**9. SPI data transfer hangs with CSR0.CSAAT==1 and MR.MODFDIS==0**

When CSR0.CSAAT==1 and mode fault detection is enabled (MR.MODFDIS==0), the SPI module will not start a data transfer.

**Fix/Workaround**

Disable mode fault detection by writing a one to MR.MODFDIS.

**10. Disabling SPI has no effect on the SR.TDRE bit**

Disabling SPI has no effect on the SR.TDRE bit whereas the write data command is filtered when SPI is disabled. Writing to TDR when SPI is disabled will not clear SR.TDRE. If SPI is disabled during a PDCA transfer, the PDCA will continue to write data to TDR until its buffer is empty, and this data will be lost.

**Fix/Workaround**

Disable the PDCA, add two NOPs, and disable the SPI. To continue the transfer, enable the SPI and PDCA.

**11. Power Manager**

**12. If the BOD level is higher than VDDCORE, the part is constantly reset**

If the BOD level is set to a value higher than VDDCORE and enabled by fuses, the part will be in constant reset.

**Fix/Workaround**

Apply an external voltage on VDDCORE that is higher than the BOD level and is lower than VDDCORE max and disable the BOD.

**13. When the main clock is RCSYS, TIMER\_CLOCK5 is equal to PBA clock**

When the main clock is generated from RCSYS, TIMER\_CLOCK5 is equal to PBA Clock and not PBA Clock / 128.

**Fix/Workaround**

None.

**14. Clock sources will not be stopped in STATIC sleep mode if the difference between CPU and PBx division factor is too high**

If the division factor between the CPU/HSB and PBx frequencies is more than 4 when going to a sleep mode where the system RC oscillator is turned off, then high speed clock sources

will not be turned off. This will result in a significantly higher power consumption during the sleep mode.

**Fix/Workaround**

Before going to sleep modes where the system RC oscillator is stopped, make sure that the factor between the CPU/HSB and PBx frequencies is less than or equal to 4.

**15. Increased Power Consumption in VDDIO in sleep modes**

If the OSC0 is enabled in crystal mode when entering a sleep mode where the OSC0 is disabled, this will lead to an increased power consumption in VDDIO.

**Fix/Workaround**

Disable the OSC0 through the Power Manager (PM) before going to any sleep mode where the OSC0 is disabled, or pull down or up XIN0 and XOUT0 with 1Mohm resistor.

**16. SSC**

**17. Additional delay on TD output**

A delay from 2 to 3 system clock cycles is added to TD output when:

TCMR.START = Receive Start,

TCMR.STTDLY = more than ZERO,

RCMR.START = Start on falling edge / Start on Rising edge / Start on any edge,

RFMR.FSOS = None (input).

**Fix/Workaround**

None.

**18. TF output is not correct**

TF output is not correct (at least emitted one serial clock cycle later than expected) when:

TFMR.FSOS = Driven Low during data transfer/ Driven High during data transfer

TCMR.START = Receive start

RFMR.FSOS = None (Input)

RCMR.START = any on RF (edge/level)

**Fix/Workaround**

None.

**19. Frame Synchro and Frame Synchro Data are delayed by one clock cycle**

The frame synchro and the frame synchro data are delayed from 1 SSC\_CLOCK when:

- Clock is CKDIV

- The START is selected on either a frame synchro edge or a level

- Frame synchro data is enabled

- Transmit clock is gated on output (through CKO field)

**Fix/Workaround**

Transmit or receive CLOCK must not be gated (by the mean of CKO field) when START condition is performed on a generated frame synchro.



## 20. USB

### 21. UPCFGn.INTFRQ is irrelevant for isochronous pipe

As a consequence, isochronous IN and OUT tokens are sent every 1 ms (Full Speed), or every 125µs (High Speed).

#### Fix/Workaround

For higher polling time, the software must freeze the pipe for the desired period in order to prevent any "extra" token.

- ADC

#### 1. Sleep Mode activation needs additional A to D conversion

If the ADC sleep mode is activated when the ADC is idle the ADC will not enter sleep mode before after the next AD conversion.

#### Fix/Workaround

Activate the sleep mode in the mode register and then perform an AD conversion.

- PDCA

#### 1. Wrong PDCA behavior when using two PDCA channels with the same PID

Wrong PDCA behavior when using two PDCA channels with the same PID.

#### Fix/Workaround

The same PID should not be assigned to more than one channel.

#### 2. Transfer error will stall a transmit peripheral handshake interface

If a transfer error is encountered on a channel transmitting to a peripheral, the peripheral handshake of the active channel will stall and the PDCA will not do any more transfers on the affected peripheral handshake interface.

#### Fix/Workaround

Disable and then enable the peripheral after the transfer error.

#### 3. TWI

#### 4. The TWI RXRDY flag in SR register is not reset when a software reset is performed

The TWI RXRDY flag in SR register is not reset when a software reset is performed.

#### Fix/Workaround

After a Software Reset, the register TWI RHR must be read.

#### 5. TWI in master mode will continue to read data

TWI in master mode will continue to read data on the line even if the shift register and the RHR register are full. This will generate an overrun error.

#### Fix/Workaround

To prevent this, read the RHR register as soon as a new RX data is ready.

#### 6. TWI slave behaves improperly if master acknowledges the last transmitted data byte before a STOP condition

In I2C slave transmitter mode, if the master acknowledges the last data byte before a STOP condition (what the master is not supposed to do), the following TWI slave receiver mode frame may contain an inappropriate clock stretch. This clock stretch can only be stopped by resetting the TWI.

#### Fix/Workaround

If the TWI is used as a slave transmitter with a master that acknowledges the last data byte before a STOP condition, it is necessary to reset the TWI before entering slave receiver mode.

## 7. TC

8. **Channel chaining skips first pulse for upper channel**

When chaining two channels using the Block Mode Register, the first pulse of the clock between the channels is skipped.

**Fix/Workaround**

Configure the lower channel with RA = 0x1 and RC = 0x2 to produce a dummy clock cycle for the upper channel. After the dummy cycle has been generated, indicated by the SR.CPCS bit, reconfigure the RA and RC registers for the lower channel with the real values.

*- Processor and Architecture*1. **LDM instruction with PC in the register list and without ++ increments Rp**

For LDM with PC in the register list: the instruction behaves as if the ++ field is always set, ie the pointer is always updated. This happens even if the ++ field is cleared. Specifically, the increment of the pointer is done in parallel with the testing of R12.

**Fix/Workaround**

None.

2. **RETE instruction does not clear SREG[L] from interrupts**

The RETE instruction clears SREG[L] as expected from exceptions.

**Fix/Workaround**

When using the STCOND instruction, clear SREG[L] in the stacked value of SR before returning from interrupts with RETE.

3. **Privilege violation when using interrupts in application mode with protected system stack**

If the system stack is protected by the MPU and an interrupt occurs in application mode, an MPU DTLB exception will occur.

**Fix/Workaround**

Make a DTLB Protection (Write) exception handler which permits the interrupt request to be handled in privileged mode.

4. **USART**5. **ISO7816 info register US\_NER cannot be read**

The NER register always returns zero.

**Fix/Workaround**

None.

6. **ISO7816 Mode T1: RX impossible after any TX**

RX impossible after any TX.

**Fix/Workaround**

SOFT\_RESET on RX+ Config US\_MR + Config\_US\_CR.

7. **The RTS output does not function correctly in hardware handshaking mode**

The RTS signal is not generated properly when the USART receives data in hardware handshaking mode. When the Peripheral DMA receive buffer becomes full, the RTS output should go high, but it will stay low.

**Fix/Workaround**

Do not use the hardware handshaking mode of the USART. If it is necessary to drive the RTS output high when the Peripheral DMA receive buffer becomes full, use the normal mode of the USART. Configure the Peripheral DMA Controller to signal an interrupt when

the receive buffer is full. In the interrupt handler code, write a one to the RTSDIS bit in the USART Control Register (CR). This will drive the RTS output high. After the next DMA transfer is started and a receive buffer is available, write a one to the RTSEN bit in the USART CR so that RTS will be driven low.

**8. Corruption after receiving too many bits in SPI slave mode**

If the USART is in SPI slave mode and receives too much data bits (ex: 9bits instead of 8 bits) by the SPI master, an error occurs. After that, the next reception may be corrupted even if the frame is correct and the USART has been disabled, reset by a soft reset and re-enabled.

**Fix/Workaround**

None.

**9. USART slave synchronous mode external clock must be at least 9 times lower in frequency than CLK\_USART**

When the USART is operating in slave synchronous mode with an external clock, the frequency of the signal provided on CLK must be at least 9 times lower than CLK\_USART.

**Fix/Workaround**

When the USART is operating in slave synchronous mode with an external clock, provide a signal on CLK that has a frequency at least 9 times lower than CLK\_USART.

**10. HMATRIX**

**11. In the PRAS and PRBS registers, the MxPR fields are only two bits**

In the PRAS and PRBS registers, the MxPR fields are only two bits wide, instead of four bits. The unused bits are undefined when reading the registers.

**Fix/Workaround**

Mask undefined bits when reading PRAS and PRBS.

*- DSP Operations*

**1. Hardware breakpoints may corrupt MAC results**

Hardware breakpoints on MAC instructions may corrupt the destination register of the MAC instruction.

**Fix/Workaround**

Place breakpoints on earlier or later instructions.

## 12.1.2 Rev C

## - PWM

1. **PWM channel interrupt enabling triggers an interrupt**  
When enabling a PWM channel that is configured with center aligned period (CALG=1), an interrupt is signalled.  
**Fix/Workaround**  
When using center aligned mode, enable the channel and read the status before channel interrupt is enabled.
2. **PWN counter restarts at 0x0001**  
The PWM counter restarts at 0x0001 and not 0x0000 as specified. Because of this the first PWM period has one more clock cycle.  
**Fix/Workaround**
  - The first period is 0x0000, 0x0001, ..., period.
  - Consecutive periods are 0x0001, 0x0002, ..., period.
3. **PWM update period to a 0 value does not work**  
It is impossible to update a period equal to 0 by the using the PWM update register (PWM\_CUPD).  
**Fix/Workaround**  
Do not update the PWM\_CUPD register with a value equal to 0.
4. **SPI**
5. **SPI Slave / PDCA transfer: no TX UNDERRUN flag**  
There is no TX UNDERRUN flag available, therefore in SPI slave mode, there is no way to be informed of a character lost in transmission.  
**Fix/Workaround**  
For PDCA transfer: none.
6. **SPI bad serial clock generation on 2nd chip\_select when SCBR=1, CPOL=1, and NCPHA=0**  
When multiple chip selects (CS) are in use, if one of the baudrates equal 1 while one (CSRn.SCBR=1) of the others do not equal 1, and CSRn.CPOL=1 and CSRn.NCPHA=0, then an additional pulse will be generated on SCK.  
**Fix/Workaround**  
When multiple CS are in use, if one of the baudrates equals 1, the others must also equal 1 if CSRn.CPOL=1 and CSRn.NCPHA=0.
7. **SPI Glitch on RXREADY flag in slave mode when enabling the SPI or during the first transfer**  
In slave mode, the SPI can generate a false RXREADY signal during enabling of the SPI or during the first transfer.  
**Fix/Workaround**
  1. Set slave mode, set required CPOL/CPHA.
  2. Enable SPI.
  3. Set the polarity CPOL of the line in the opposite value of the required one.
  4. Set the polarity CPOL to the required one.
  5. Read the RXHOLDING register.

Transfers can now begin and RXREADY will now behave as expected.

**8. SPI disable does not work in SLAVE mode**

SPI disable does not work in SLAVE mode.

**Fix/Workaround**

Read the last received data, then perform a software reset by writing a one to the Software Reset bit in the Control Register (CR.SWRST).

**9. SPI data transfer hangs with CSR0.CSAAT==1 and MR.MODFDIS==0**

When CSR0.CSAAT==1 and mode fault detection is enabled (MR.MODFDIS==0), the SPI module will not start a data transfer.

**Fix/Workaround**

Disable mode fault detection by writing a one to MR.MODFDIS.

**10. Disabling SPI has no effect on the SR.TDRE bit**

Disabling SPI has no effect on the SR.TDRE bit whereas the write data command is filtered when SPI is disabled. Writing to TDR when SPI is disabled will not clear SR.TDRE. If SPI is disabled during a PDCA transfer, the PDCA will continue to write data to TDR until its buffer is empty, and this data will be lost.

**Fix/Workaround**

Disable the PDCA, add two NOPs, and disable the SPI. To continue the transfer, enable the SPI and PDCA.

**11. Power Manager****12. If the BOD level is higher than VDDCORE, the part is constantly reset**

If the BOD level is set to a value higher than VDDCORE and enabled by fuses, the part will be in constant reset.

**Fix/Workaround**

Apply an external voltage on VDDCORE that is higher than the BOD level and is lower than VDDCORE max and disable the BOD.

**13. When the main clock is RCSYS, TIMER\_CLOCK5 is equal to PBA clock**

When the main clock is generated from RCSYS, TIMER\_CLOCK5 is equal to PBA Clock and not PBA Clock / 128.

**Fix/Workaround**

None.

**14. VDDCORE power supply input needs to be 1.95V**

When used in dual power supply, VDDCORE needs to be 1.95V.

**Fix/Workaround**

When used in single power supply, VDDCORE needs to be connected to VDDOUT, which is configured on revision C at 1.95V (typ.).

**15. Clock sources will not be stopped in STATIC sleep mode if the difference between CPU and PBx division factor is too high**

If the division factor between the CPU/HSB and PBx frequencies is more than 4 when going to a sleep mode where the system RC oscillator is turned off, then high speed clock sources will not be turned off. This will result in a significantly higher power consumption during the sleep mode.

**Fix/Workaround**

Before going to sleep modes where the system RC oscillator is stopped, make sure that the factor between the CPU/HSB and PBx frequencies is less than or equal to 4.

**16. Increased Power Consumption in VDDIO in sleep modes**

If the OSC0 is enabled in crystal mode when entering a sleep mode where the OSC0 is disabled, this will lead to an increased power consumption in VDDIO.

**Fix/Workaround**

Disable the OSC0 through the Power Manager (PM) before going to any sleep mode where the OSC0 is disabled, or pull down or up XIN0 and XOUT0 with 1Mohm resistor.

**17. SSC****18. Additional delay on TD output**

A delay from 2 to 3 system clock cycles is added to TD output when:

TCMR.START = Receive Start,

TCMR.STTDLY = more than ZERO,

RCMR.START = Start on falling edge / Start on Rising edge / Start on any edge,

RFMR.FSOS = None (input).

**Fix/Workaround**

None.

**19. TF output is not correct**

TF output is not correct (at least emitted one serial clock cycle later than expected) when:

TFMR.FSOS = Driven Low during data transfer/ Driven High during data transfer

TCMR.START = Receive start

RFMR.FSOS = None (Input)

RCMR.START = any on RF (edge/level)

**Fix/Workaround**

None.

**20. Frame Synchro and Frame Synchro Data are delayed by one clock cycle**

The frame synchro and the frame synchro data are delayed from 1 SSC\_CLOCK when:

- Clock is CKDIV

- The START is selected on either a frame synchro edge or a level

- Frame synchro data is enabled

- Transmit clock is gated on output (through CKO field)

**Fix/Workaround**

Transmit or receive CLOCK must not be gated (by the mean of CKO field) when START condition is performed on a generated frame synchro.

**21. USB****22. UPCFGn.INTFRQ is irrelevant for isochronous pipe**

As a consequence, isochronous IN and OUT tokens are sent every 1ms (Full Speed), or every 125uS (High Speed).

**Fix/Workaround**

For higher polling time, the software must freeze the pipe for the desired period in order to prevent any "extra" token.

- ADC

**1. Sleep Mode activation needs additional A to D conversion**

If the ADC sleep mode is activated when the ADC is idle the ADC will not enter sleep mode before after the next AD conversion.

**Fix/Workaround**

Activate the sleep mode in the mode register and then perform an AD conversion.

## - PDCA

- 1. Wrong PDCA behavior when using two PDCA channels with the same PID**  
Wrong PDCA behavior when using two PDCA channels with the same PID.  
**Fix/Workaround**  
The same PID should not be assigned to more than one channel.
- 2. Transfer error will stall a transmit peripheral handshake interface**  
If a transfer error is encountered on a channel transmitting to a peripheral, the peripheral handshake of the active channel will stall and the PDCA will not do any more transfers on the affected peripheral handshake interface.  
**Fix/Workaround**  
Disable and then enable the peripheral after the transfer error.
- 3. TWI**
- 4. The TWI RXRDY flag in SR register is not reset when a software reset is performed**  
The TWI RXRDY flag in SR register is not reset when a software reset is performed.  
**Fix/Workaround**  
After a Software Reset, the register TWI RHR must be read.
- 5. TWI in master mode will continue to read data**  
TWI in master mode will continue to read data on the line even if the shift register and the RHR register are full. This will generate an overrun error.  
**Fix/Workaround**  
To prevent this, read the RHR register as soon as a new RX data is ready.
- 6. TWI slave behaves improperly if master acknowledges the last transmitted data byte before a STOP condition**  
In I2C slave transmitter mode, if the master acknowledges the last data byte before a STOP condition (what the master is not supposed to do), the following TWI slave receiver mode frame may contain an inappropriate clock stretch. This clock stretch can only be stopped by resetting the TWI.  
**Fix/Workaround**  
If the TWI is used as a slave transmitter with a master that acknowledges the last data byte before a STOP condition, it is necessary to reset the TWI before entering slave receiver mode.
- 7. TC**
- 8. Channel chaining skips first pulse for upper channel**  
When chaining two channels using the Block Mode Register, the first pulse of the clock between the channels is skipped.  
**Fix/Workaround**  
Configure the lower channel with RA = 0x1 and RC = 0x2 to produce a dummy clock cycle for the upper channel. After the dummy cycle has been generated, indicated by the SR.CPCS bit, reconfigure the RA and RC registers for the lower channel with the real values.

- *Processor and Architecture*

1. **LDM instruction with PC in the register list and without ++ increments Rp**

For LDM with PC in the register list: the instruction behaves as if the ++ field is always set, ie the pointer is always updated. This happens even if the ++ field is cleared. Specifically, the increment of the pointer is done in parallel with the testing of R12.

**Fix/Workaround**

None.

2. **RETE instruction does not clear SREG[L] from interrupts**

The RETE instruction clears SREG[L] as expected from exceptions.

**Fix/Workaround**

When using the STCOND instruction, clear SREG[L] in the stacked value of SR before returning from interrupts with RETE.

3. **Privilege violation when using interrupts in application mode with protected system stack**

If the system stack is protected by the MPU and an interrupt occurs in application mode, an MPU DTLB exception will occur.

**Fix/Workaround**

Make a DTLB Protection (Write) exception handler which permits the interrupt request to be handled in privileged mode.

4. **Flash**

5. **Reset vector is 80000020h rather than 80000000h**

Reset vector is 80000020h rather than 80000000h.

**Fix/Workaround**

The flash program code must start at the address 80000020h. The flash memory range 80000000h-80000020h must be programmed with 00000000h.

- *USART*

1. **ISO7816 info register US\_NER cannot be read**

The NER register always returns zero.

**Fix/Workaround**

None.

2. **ISO7816 Mode T1: RX impossible after any TX**

RX impossible after any TX.

**Fix/Workaround**

SOFT\_RESET on RX+ Config US\_MR + Config\_US\_CR.

3. **The RTS output does not function correctly in hardware handshaking mode**

The RTS signal is not generated properly when the USART receives data in hardware handshaking mode. When the Peripheral DMA receive buffer becomes full, the RTS output should go high, but it will stay low.

**Fix/Workaround**

Do not use the hardware handshaking mode of the USART. If it is necessary to drive the RTS output high when the Peripheral DMA receive buffer becomes full, use the normal mode of the USART. Configure the Peripheral DMA Controller to signal an interrupt when the receive buffer is full. In the interrupt handler code, write a one to the RTSDIS bit in the USART Control Register (CR). This will drive the RTS output high. After the next DMA trans-



fer is started and a receive buffer is available, write a one to the RTSEN bit in the USART CR so that RTS will be driven low.

**4. Corruption after receiving too many bits in SPI slave mode**

If the USART is in SPI slave mode and receives too much data bits (ex: 9bits instead of 8 bits) by the SPI master, an error occurs. After that, the next reception may be corrupted even if the frame is correct and the USART has been disabled, reset by a soft reset and re-enabled.

**Fix/Workaround**

None.

**5. USART slave synchronous mode external clock must be at least 9 times lower in frequency than CLK\_USART**

When the USART is operating in slave synchronous mode with an external clock, the frequency of the signal provided on CLK must be at least 9 times lower than CLK\_USART.

**Fix/Workaround**

When the USART is operating in slave synchronous mode with an external clock, provide a signal on CLK that has a frequency at least 9 times lower than CLK\_USART.

**6. HMATRIX**

**7. In the PRAS and PRBS registers, the MxPR fields are only two bits**

In the PRAS and PRBS registers, the MxPR fields are only two bits wide, instead of four bits. The unused bits are undefined when reading the registers.

**Fix/Workaround**

Mask undefined bits when reading PRAS and PRBS.

*- DSP Operations*

**1. Hardware breakpoints may corrupt MAC results**

Hardware breakpoints on MAC instructions may corrupt the destination register of the MAC instruction.

**Fix/Workaround**

Place breakpoints on earlier or later instructions.

## 12.2 AT32UC3B0256, AT32UC3B0128, AT32UC3B064, AT32UC3B1256, AT32UC3B1128, AT32UC3B164

All industrial parts labelled with -UES (for engineering samples) are revision B parts.

### 12.2.1 Rev I, J, K

- PWM

- 1. PWM channel interrupt enabling triggers an interrupt**  
 When enabling a PWM channel that is configured with center aligned period (CALG=1), an interrupt is signalled.  
**Fix/Workaround**  
 When using center aligned mode, enable the channel and read the status before channel interrupt is enabled.
- 2. PWN counter restarts at 0x0001**  
 The PWM counter restarts at 0x0001 and not 0x0000 as specified. Because of this the first PWM period has one more clock cycle.  
**Fix/Workaround**  
 - The first period is 0x0000, 0x0001, ..., period.  
 - Consecutive periods are 0x0001, 0x0002, ..., period.
- 3. PWM update period to a 0 value does not work**  
 It is impossible to update a period equal to 0 by the using the PWM update register (PWM\_CUPD).  
**Fix/Workaround**  
 Do not update the PWM\_CUPD register with a value equal to 0.
- 4. SPI**
- 5. SPI Slave / PDCA transfer: no TX UNDERRUN flag**  
 There is no TX UNDERRUN flag available, therefore in SPI slave mode, there is no way to be informed of a character lost in transmission.  
**Fix/Workaround**  
 For PDCA transfer: none.
- 6. SPI bad serial clock generation on 2nd chip\_select when SCBR=1, CPOL=1, and NCPHA=0**  
 When multiple chip selects (CS) are in use, if one of the baudrates equal 1 while one (CSRn.SCBR=1) of the others do not equal 1, and CSRn.CPOL=1 and CSRn.NCPHA=0, then an additional pulse will be generated on SCK.  
**Fix/Workaround**  
 When multiple CS are in use, if one of the baudrates equals 1, the others must also equal 1 if CSRn.CPOL=1 and CSRn.NCPHA=0.
- 7. SPI Glitch on RXREADY flag in slave mode when enabling the SPI or during the first transfer**  
 In slave mode, the SPI can generate a false RXREADY signal during enabling of the SPI or during the first transfer.  
**Fix/Workaround**  
 1. Set slave mode, set required CPOL/CPHA.  
 2. Enable SPI.

3. Set the polarity CPOL of the line in the opposite value of the required one.
  4. Set the polarity CPOL to the required one.
  5. Read the RXHOLDING register.
- Transfers can now begin and RXREADY will now behave as expected.

#### 8. SPI disable does not work in SLAVE mode

SPI disable does not work in SLAVE mode.

##### Fix/Workaround

Read the last received data, then perform a software reset by writing a one to the Software Reset bit in the Control Register (CR.SWRST).

#### 9. SPI data transfer hangs with CSR0.CSAAT==1 and MR.MODFDIS==0

When CSR0.CSAAT==1 and mode fault detection is enabled (MR.MODFDIS==0), the SPI module will not start a data transfer.

##### Fix/Workaround

Disable mode fault detection by writing a one to MR.MODFDIS.

#### 10. Disabling SPI has no effect on the SR.TDRE bit

Disabling SPI has no effect on the SR.TDRE bit whereas the write data command is filtered when SPI is disabled. Writing to TDR when SPI is disabled will not clear SR.TDRE. If SPI is disabled during a PDCA transfer, the PDCA will continue to write data to TDR until its buffer is empty, and this data will be lost.

##### Fix/Workaround

Disable the PDCA, add two NOPs, and disable the SPI. To continue the transfer, enable the SPI and PDCA.

#### 11. Power Manager

#### 12. If the BOD level is higher than VDDCORE, the part is constantly reset

If the BOD level is set to a value higher than VDDCORE and enabled by fuses, the part will be in constant reset.

##### Fix/Workaround

Apply an external voltage on VDDCORE that is higher than the BOD level and is lower than VDDCORE max and disable the BOD.

#### 1. When the main clock is RCSYS, TIMER\_CLOCK5 is equal to PBA clock

When the main clock is generated from RCSYS, TIMER\_CLOCK5 is equal to PBA Clock and not PBA Clock / 128.

##### Fix/Workaround

None.

#### 13. Clock sources will not be stopped in STATIC sleep mode if the difference between CPU and PBx division factor is too high

If the division factor between the CPU/HSB and PBx frequencies is more than 4 when going to a sleep mode where the system RC oscillator is turned off, then high speed clock sources will not be turned off. This will result in a significantly higher power consumption during the sleep mode.

##### Fix/Workaround

Before going to sleep modes where the system RC oscillator is stopped, make sure that the factor between the CPU/HSB and PBx frequencies is less than or equal to 4.

## 14. SSC

### 15. Additional delay on TD output

A delay from 2 to 3 system clock cycles is added to TD output when:

TCMR.START = Receive Start,

TCMR.STTDLY = more than ZERO,

RCMR.START = Start on falling edge / Start on Rising edge / Start on any edge,

RFMR.FSOS = None (input).

#### Fix/Workaround

None.

### 16. TF output is not correct

TF output is not correct (at least emitted one serial clock cycle later than expected) when:

TFMR.FSOS = Driven Low during data transfer/ Driven High during data transfer

TCMR.START = Receive start

RFMR.FSOS = None (Input)

RCMR.START = any on RF (edge/level)

#### Fix/Workaround

None.

### 17. Frame Synchro and Frame Synchro Data are delayed by one clock cycle

The frame synchro and the frame synchro data are delayed from 1 SSC\_CLOCK when:

- Clock is CKDIV

- The START is selected on either a frame synchro edge or a level

- Frame synchro data is enabled

- Transmit clock is gated on output (through CKO field)

#### Fix/Workaround

Transmit or receive CLOCK must not be gated (by the mean of CKO field) when START condition is performed on a generated frame synchro.

## 18. USB

### 19. UPCFGn.INTFRQ is irrelevant for isochronous pipe

As a consequence, isochronous IN and OUT tokens are sent every 1ms (Full Speed), or every 125uS (High Speed).

#### Fix/Workaround

For higher polling time, the software must freeze the pipe for the desired period in order to prevent any "extra" token.

- ADC

### 1. Sleep Mode activation needs additional A to D conversion

If the ADC sleep mode is activated when the ADC is idle the ADC will not enter sleep mode before after the next AD conversion.

#### Fix/Workaround

Activate the sleep mode in the mode register and then perform an AD conversion.

- PDCA

### 1. Wrong PDCA behavior when using two PDCA channels with the same PID

Wrong PDCA behavior when using two PDCA channels with the same PID.

#### Fix/Workaround

The same PID should not be assigned to more than one channel.

2. **Transfer error will stall a transmit peripheral handshake interface**  
 If a transfer error is encountered on a channel transmitting to a peripheral, the peripheral handshake of the active channel will stall and the PDCA will not do any more transfers on the affected peripheral handshake interface.  
**Fix/Workaround**  
 Disable and then enable the peripheral after the transfer error.
  3. **TWI**
  4. **The TWI RXRDY flag in SR register is not reset when a software reset is performed**  
 The TWI RXRDY flag in SR register is not reset when a software reset is performed.  
**Fix/Workaround**  
 After a Software Reset, the register TWI RHR must be read.
  5. **TWI in master mode will continue to read data**  
 TWI in master mode will continue to read data on the line even if the shift register and the RHR register are full. This will generate an overrun error.  
**Fix/Workaround**  
 To prevent this, read the RHR register as soon as a new RX data is ready.
  6. **TWI slave behaves improperly if master acknowledges the last transmitted data byte before a STOP condition**  
 In I2C slave transmitter mode, if the master acknowledges the last data byte before a STOP condition (what the master is not supposed to do), the following TWI slave receiver mode frame may contain an inappropriate clock stretch. This clock stretch can only be stopped by resetting the TWI.  
**Fix/Workaround**  
 If the TWI is used as a slave transmitter with a master that acknowledges the last data byte before a STOP condition, it is necessary to reset the TWI before entering slave receiver mode.
  7. **TC**
  8. **Channel chaining skips first pulse for upper channel**  
 When chaining two channels using the Block Mode Register, the first pulse of the clock between the channels is skipped.  
**Fix/Workaround**  
 Configure the lower channel with RA = 0x1 and RC = 0x2 to produce a dummy clock cycle for the upper channel. After the dummy cycle has been generated, indicated by the SR.CPCS bit, reconfigure the RA and RC registers for the lower channel with the real values.
- OCD
1. **The auxiliary trace does not work for CPU/HSB speed higher than 50MHz**  
 The auxiliary trace does not work for CPU/HSB speed higher than 50MHz.  
**Fix/Workaround**  
 Do not use the auxiliary trace for CPU/HSB speed higher than 50MHz.

## - Processor and Architecture

1. **LDM instruction with PC in the register list and without ++ increments Rp**  
 For LDM with PC in the register list: the instruction behaves as if the ++ field is always set, ie the pointer is always updated. This happens even if the ++ field is cleared. Specifically, the increment of the pointer is done in parallel with the testing of R12.  
**Fix/Workaround**  
 None.
2. **RETE instruction does not clear SREG[L] from interrupts**  
 The RETE instruction clears SREG[L] as expected from exceptions.  
**Fix/Workaround**  
 When using the STCOND instruction, clear SREG[L] in the stacked value of SR before returning from interrupts with RETE.
3. **Privilege violation when using interrupts in application mode with protected system stack**  
 If the system stack is protected by the MPU and an interrupt occurs in application mode, an MPU DTLB exception will occur.  
**Fix/Workaround**  
 Make a DTLB Protection (Write) exception handler which permits the interrupt request to be handled in privileged mode.
4. **USART**
5. **ISO7816 info register US\_NER cannot be read**  
 The NER register always returns zero.  
**Fix/Workaround**  
 None.
6. **ISO7816 Mode T1: RX impossible after any TX**  
 RX impossible after any TX.  
**Fix/Workaround**  
 SOFT\_RESET on RX+ Config US\_MR + Config\_US\_CR.
7. **The RTS output does not function correctly in hardware handshaking mode**  
 The RTS signal is not generated properly when the USART receives data in hardware handshaking mode. When the Peripheral DMA receive buffer becomes full, the RTS output should go high, but it will stay low.  
**Fix/Workaround**  
 Do not use the hardware handshaking mode of the USART. If it is necessary to drive the RTS output high when the Peripheral DMA receive buffer becomes full, use the normal mode of the USART. Configure the Peripheral DMA Controller to signal an interrupt when the receive buffer is full. In the interrupt handler code, write a one to the RTSDIS bit in the USART Control Register (CR). This will drive the RTS output high. After the next DMA transfer is started and a receive buffer is available, write a one to the RTSEN bit in the USART CR so that RTS will be driven low.
8. **Corruption after receiving too many bits in SPI slave mode**  
 If the USART is in SPI slave mode and receives too much data bits (ex: 9bits instead of 8 bits) by the SPI master, an error occurs. After that, the next reception may be corrupted

even if the frame is correct and the USART has been disabled, reset by a soft reset and re-enabled.

**Fix/Workaround**

None.

**9. USART slave synchronous mode external clock must be at least 9 times lower in frequency than CLK\_USART**

When the USART is operating in slave synchronous mode with an external clock, the frequency of the signal provided on CLK must be at least 9 times lower than CLK\_USART.

**Fix/Workaround**

When the USART is operating in slave synchronous mode with an external clock, provide a signal on CLK that has a frequency at least 9 times lower than CLK\_USART.

**10. HMATRIX**

**11. In the PRAS and PRBS registers, the MxPR fields are only two bits**

In the PRAS and PRBS registers, the MxPR fields are only two bits wide, instead of four bits. The unused bits are undefined when reading the registers.

**Fix/Workaround**

Mask undefined bits when reading PRAS and PRBS.

- FLASHC

**1. Reading from on-chip flash may fail after a flash fuse write operation (FLASHC LP, UP, WGPB, EGPB, SSB, PGPFB, EAGPF commands).**

After a flash fuse write operation (FLASHC LP, UP, WGPB, EGPB, SSB, PGPFB, EAGPF commands), the following flash read access may return corrupted data. This erratum does not affect write operations to regular flash memory.

**Fix/Workaround**

The flash fuse write operation (FLASHC LP, UP, WGPB, EGPB, SSB, PGPFB, EAGPF commands) must be issued from internal RAM. After the write operation, perform a dummy flash page write operation (FLASHC WP). Content and location of this page is not important and filling the write buffer with all one (FFh) will leave the current flash content unchanged. It is then safe to read and fetch code from the flash.

- DSP Operations

**1. Hardware breakpoints may corrupt MAC results**

Hardware breakpoints on MAC instructions may corrupt the destination register of the MAC instruction.

**Fix/Workaround**

Place breakpoints on earlier or later instructions.

## 12.2.2 Rev. G

- PWM

1. **PWM channel interrupt enabling triggers an interrupt**  
When enabling a PWM channel that is configured with center aligned period (CALG=1), an interrupt is signalled.  
**Fix/Workaround**  
When using center aligned mode, enable the channel and read the status before channel interrupt is enabled.
2. **PWN counter restarts at 0x0001**  
The PWM counter restarts at 0x0001 and not 0x0000 as specified. Because of this the first PWM period has one more clock cycle.  
**Fix/Workaround**
  - The first period is 0x0000, 0x0001, ..., period.
  - Consecutive periods are 0x0001, 0x0002, ..., period.
3. **PWM update period to a 0 value does not work**  
It is impossible to update a period equal to 0 by the using the PWM update register (PWM\_CUPD).  
**Fix/Workaround**  
Do not update the PWM\_CUPD register with a value equal to 0.
4. **SPI**
5. **SPI Slave / PDCA transfer: no TX UNDERRUN flag**  
There is no TX UNDERRUN flag available, therefore in SPI slave mode, there is no way to be informed of a character lost in transmission.  
**Fix/Workaround**  
For PDCA transfer: none.
6. **SPI bad serial clock generation on 2nd chip\_select when SCBR=1, CPOL=1, and NCPHA=0**  
When multiple chip selects (CS) are in use, if one of the baudrates equal 1 while one (CSRn.SCBR=1) of the others do not equal 1, and CSRn.CPOL=1 and CSRn.NCPHA=0, then an additional pulse will be generated on SCK.  
**Fix/Workaround**  
When multiple CS are in use, if one of the baudrates equals 1, the others must also equal 1 if CSRn.CPOL=1 and CSRn.NCPHA=0.
7. **SPI Glitch on RXREADY flag in slave mode when enabling the SPI or during the first transfer**  
In slave mode, the SPI can generate a false RXREADY signal during enabling of the SPI or during the first transfer.  
**Fix/Workaround**
  1. Set slave mode, set required CPOL/CPHA.
  2. Enable SPI.
  3. Set the polarity CPOL of the line in the opposite value of the required one.
  4. Set the polarity CPOL to the required one.
  5. Read the RXHOLDING register.

Transfers can now begin and RXREADY will now behave as expected.



**8. SPI disable does not work in SLAVE mode**

SPI disable does not work in SLAVE mode.

**Fix/Workaround**

Read the last received data, then perform a software reset by writing a one to the Software Reset bit in the Control Register (CR.SWRST).

**9. SPI data transfer hangs with CSR0.CSAAT==1 and MR.MODFDIS==0**

When CSR0.CSAAT==1 and mode fault detection is enabled (MR.MODFDIS==0), the SPI module will not start a data transfer.

**Fix/Workaround**

Disable mode fault detection by writing a one to MR.MODFDIS.

**10. Disabling SPI has no effect on the SR.TDRE bit**

Disabling SPI has no effect on the SR.TDRE bit whereas the write data command is filtered when SPI is disabled. Writing to TDR when SPI is disabled will not clear SR.TDRE. If SPI is disabled during a PDCA transfer, the PDCA will continue to write data to TDR until its buffer is empty, and this data will be lost.

**Fix/Workaround**

Disable the PDCA, add two NOPs, and disable the SPI. To continue the transfer, enable the SPI and PDCA.

**11. Power Manager****12. If the BOD level is higher than VDDCORE, the part is constantly reset**

If the BOD level is set to a value higher than VDDCORE and enabled by fuses, the part will be in constant reset.

**Fix/Workaround**

Apply an external voltage on VDDCORE that is higher than the BOD level and is lower than VDDCORE max and disable the BOD.

**2. When the main clock is RCSYS, TIMER\_CLOCK5 is equal to PBA clock**

When the main clock is generated from RCSYS, TIMER\_CLOCK5 is equal to PBA Clock and not PBA Clock / 128.

**Fix/Workaround**

None.

**13. Clock sources will not be stopped in STATIC sleep mode if the difference between CPU and PBx division factor is too high**

If the division factor between the CPU/HSB and PBx frequencies is more than 4 when going to a sleep mode where the system RC oscillator is turned off, then high speed clock sources will not be turned off. This will result in a significantly higher power consumption during the sleep mode.

**Fix/Workaround**

Before going to sleep modes where the system RC oscillator is stopped, make sure that the factor between the CPU/HSB and PBx frequencies is less than or equal to 4.

**14. Increased Power Consumption in VDDIO in sleep modes**

If the OSC0 is enabled in crystal mode when entering a sleep mode where the OSC0 is disabled, this will lead to an increased power consumption in VDDIO.

**Fix/Workaround**

Disable the OSC0 through the System Control Interface (SCIF) before going to any sleep mode where the OSC0 is disabled, or pull down or up XIN0 and XOUT0 with 1 Mohm resistor.

**15. SSC****16. Additional delay on TD output**

A delay from 2 to 3 system clock cycles is added to TD output when:

TCMR.START = Receive Start,

TCMR.STTDLY = more than ZERO,

RCMR.START = Start on falling edge / Start on Rising edge / Start on any edge,

RFMR.FSOS = None (input).

**Fix/Workaround**

None.

**17. TF output is not correct**

TF output is not correct (at least emitted one serial clock cycle later than expected) when:

TFMR.FSOS = Driven Low during data transfer/ Driven High during data transfer

TCMR.START = Receive start

RFMR.FSOS = None (Input)

RCMR.START = any on RF (edge/level)

**Fix/Workaround**

None.

**18. Frame Synchro and Frame Synchro Data are delayed by one clock cycle**

The frame synchro and the frame synchro data are delayed from 1 SSC\_CLOCK when:

- Clock is CKDIV

- The START is selected on either a frame synchro edge or a level

- Frame synchro data is enabled

- Transmit clock is gated on output (through CKO field)

**Fix/Workaround**

Transmit or receive CLOCK must not be gated (by the mean of CKO field) when START condition is performed on a generated frame synchro.

**19. USB****20. UPCFGn.INTFRQ is irrelevant for isochronous pipe**

As a consequence, isochronous IN and OUT tokens are sent every 1ms (Full Speed), or every 125uS (High Speed).

**Fix/Workaround**

For higher polling time, the software must freeze the pipe for the desired period in order to prevent any "extra" token.

- ADC

**1. Sleep Mode activation needs additional A to D conversion**

If the ADC sleep mode is activated when the ADC is idle the ADC will not enter sleep mode before after the next AD conversion.

**Fix/Workaround**

Activate the sleep mode in the mode register and then perform an AD conversion.

- PDCA

**1. Wrong PDCA behavior when using two PDCA channels with the same PID**

Wrong PDCA behavior when using two PDCA channels with the same PID.

**Fix/Workaround**

The same PID should not be assigned to more than one channel.



2. **Transfer error will stall a transmit peripheral handshake interface**  
 If a transfer error is encountered on a channel transmitting to a peripheral, the peripheral handshake of the active channel will stall and the PDCA will not do any more transfers on the affected peripheral handshake interface.  
**Fix/Workaround**  
 Disable and then enable the peripheral after the transfer error.
3. **TWI**
4. **The TWI RXRDY flag in SR register is not reset when a software reset is performed**  
 The TWI RXRDY flag in SR register is not reset when a software reset is performed.  
**Fix/Workaround**  
 After a Software Reset, the register TWI RHR must be read.
5. **TWI in master mode will continue to read data**  
 TWI in master mode will continue to read data on the line even if the shift register and the RHR register are full. This will generate an overrun error.  
**Fix/Workaround**  
 To prevent this, read the RHR register as soon as a new RX data is ready.
6. **TWI slave behaves improperly if master acknowledges the last transmitted data byte before a STOP condition**  
 In I2C slave transmitter mode, if the master acknowledges the last data byte before a STOP condition (what the master is not supposed to do), the following TWI slave receiver mode frame may contain an inappropriate clock stretch. This clock stretch can only be stopped by resetting the TWI.  
**Fix/Workaround**  
 If the TWI is used as a slave transmitter with a master that acknowledges the last data byte before a STOP condition, it is necessary to reset the TWI before entering slave receiver mode.
7. **GPIO**
8. **PA29 (TWI SDA) and PA30 (TWI SCL) GPIO VIH (input high voltage) is 3.6V max instead of 5V tolerant**  
 The following GPIOs are not 5V tolerant: PA29 and PA30.  
**Fix/Workaround**  
 None.

- TC

1. **Channel chaining skips first pulse for upper channel**  
 When chaining two channels using the Block Mode Register, the first pulse of the clock between the channels is skipped.  
**Fix/Workaround**  
 Configure the lower channel with RA = 0x1 and RC = 0x2 to produce a dummy clock cycle for the upper channel. After the dummy cycle has been generated, indicated by the SR.CPCS bit, reconfigure the RA and RC registers for the lower channel with the real values.

- *OCD***1. The auxiliary trace does not work for CPU/HSB speed higher than 50MHz**

The auxiliary trace does not work for CPU/HSB speed higher than 50MHz.

**Fix/Workaround**

Do not use the auxiliary trace for CPU/HSB speed higher than 50MHz.

- *Processor and Architecture***1. LDM instruction with PC in the register list and without ++ increments Rp**

For LDM with PC in the register list: the instruction behaves as if the ++ field is always set, ie the pointer is always updated. This happens even if the ++ field is cleared. Specifically, the increment of the pointer is done in parallel with the testing of R12.

**Fix/Workaround**

None.

**2. RETE instruction does not clear SREG[L] from interrupts**

The RETE instruction clears SREG[L] as expected from exceptions.

**Fix/Workaround**

When using the STCOND instruction, clear SREG[L] in the stacked value of SR before returning from interrupts with RETE.

**3. RETS behaves incorrectly when MPU is enabled**

RETS behaves incorrectly when MPU is enabled and MPU is configured so that system stack is not readable in unprivileged mode.

**Fix/Workaround**

Make system stack readable in unprivileged mode, or return from supervisor mode using rete instead of rets. This requires:

1. Changing the mode bits from 001 to 110 before issuing the instruction. Updating the mode bits to the desired value must be done using a single mtsr instruction so it is done atomically. Even if this step is generally described as not safe in the UC technical reference manual, it is safe in this very specific case.
2. Execute the RETE instruction.

**4. Privilege violation when using interrupts in application mode with protected system stack**

If the system stack is protected by the MPU and an interrupt occurs in application mode, an MPU DTLB exception will occur.

**Fix/Workaround**

Make a DTLB Protection (Write) exception handler which permits the interrupt request to be handled in privileged mode.

**5. USART****6. ISO7816 info register US\_NER cannot be read**

The NER register always returns zero.

**Fix/Workaround**

None.

**7. ISO7816 Mode T1: RX impossible after any TX**

RX impossible after any TX.

**Fix/Workaround**

SOFT\_RESET on RX+ Config US\_MR + Config\_US\_CR.

**8. The RTS output does not function correctly in hardware handshaking mode**

The RTS signal is not generated properly when the USART receives data in hardware handshaking mode. When the Peripheral DMA receive buffer becomes full, the RTS output should go high, but it will stay low.

**Fix/Workaround**

Do not use the hardware handshaking mode of the USART. If it is necessary to drive the RTS output high when the Peripheral DMA receive buffer becomes full, use the normal mode of the USART. Configure the Peripheral DMA Controller to signal an interrupt when the receive buffer is full. In the interrupt handler code, write a one to the RTSDIS bit in the USART Control Register (CR). This will drive the RTS output high. After the next DMA transfer is started and a receive buffer is available, write a one to the RTSEN bit in the USART CR so that RTS will be driven low.

**9. Corruption after receiving too many bits in SPI slave mode**

If the USART is in SPI slave mode and receives too much data bits (ex: 9bits instead of 8 bits) by the SPI master, an error occurs. After that, the next reception may be corrupted even if the frame is correct and the USART has been disabled, reset by a soft reset and re-enabled.

**Fix/Workaround**

None.

**10. USART slave synchronous mode external clock must be at least 9 times lower in frequency than CLK\_USART**

When the USART is operating in slave synchronous mode with an external clock, the frequency of the signal provided on CLK must be at least 9 times lower than CLK\_USART.

**Fix/Workaround**

When the USART is operating in slave synchronous mode with an external clock, provide a signal on CLK that has a frequency at least 9 times lower than CLK\_USART.

**11. HMATRIX****12. In the PRAS and PRBS registers, the MxPR fields are only two bits**

In the PRAS and PRBS registers, the MxPR fields are only two bits wide, instead of four bits. The unused bits are undefined when reading the registers.

**Fix/Workaround**

Mask undefined bits when reading PRAS and PRBS.

**- FLASHC****1. Reading from on-chip flash may fail after a flash fuse write operation (FLASHC LP, UP, WGPB, EGPB, SSB, PGPFB, EAGPF commands).**

After a flash fuse write operation (FLASHC LP, UP, WGPB, EGPB, SSB, PGPFB, EAGPF commands), the following flash read access may return corrupted data. This erratum does not affect write operations to regular flash memory.

**Fix/Workaround**

The flash fuse write operation (FLASHC LP, UP, WGPB, EGPB, SSB, PGPFB, EAGPF commands) must be issued from internal RAM. After the write operation, perform a dummy flash page write operation (FLASHC WP). Content and location of this page is not important and filling the write buffer with all one (FFh) will leave the current flash content unchanged. It is then safe to read and fetch code from the flash.

- *DSP Operations*

**1. Hardware breakpoints may corrupt MAC results**

Hardware breakpoints on MAC instructions may corrupt the destination register of the MAC instruction.

**Fix/Workaround**

Place breakpoints on earlier or later instructions.

## 12.2.3 Rev. F

- PWM

1. **PWM channel interrupt enabling triggers an interrupt**  
When enabling a PWM channel that is configured with center aligned period (CALG=1), an interrupt is signalled.  
**Fix/Workaround**  
When using center aligned mode, enable the channel and read the status before channel interrupt is enabled.
2. **PWN counter restarts at 0x0001**  
The PWM counter restarts at 0x0001 and not 0x0000 as specified. Because of this the first PWM period has one more clock cycle.  
**Fix/Workaround**
  - The first period is 0x0000, 0x0001, ..., period.
  - Consecutive periods are 0x0001, 0x0002, ..., period.
3. **PWM update period to a 0 value does not work**  
It is impossible to update a period equal to 0 by the using the PWM update register (PWM\_CUPD).  
**Fix/Workaround**  
Do not update the PWM\_CUPD register with a value equal to 0.
4. **SPI**
5. **SPI Slave / PDCA transfer: no TX UNDERRUN flag**  
There is no TX UNDERRUN flag available, therefore in SPI slave mode, there is no way to be informed of a character lost in transmission.  
**Fix/Workaround**  
For PDCA transfer: none.
6. **SPI bad serial clock generation on 2nd chip\_select when SCBR=1, CPOL=1, and NCPHA=0**  
When multiple chip selects (CS) are in use, if one of the baudrates equal 1 while one (CSRn.SCBR=1) of the others do not equal 1, and CSRn.CPOL=1 and CSRn.NCPHA=0, then an additional pulse will be generated on SCK.  
**Fix/Workaround**  
When multiple CS are in use, if one of the baudrates equals 1, the others must also equal 1 if CSRn.CPOL=1 and CSRn.NCPHA=0.
7. **SPI Glitch on RXREADY flag in slave mode when enabling the SPI or during the first transfer**  
In slave mode, the SPI can generate a false RXREADY signal during enabling of the SPI or during the first transfer.  
**Fix/Workaround**
  1. Set slave mode, set required CPOL/CPHA.
  2. Enable SPI.
  3. Set the polarity CPOL of the line in the opposite value of the required one.
  4. Set the polarity CPOL to the required one.
  5. Read the RXHOLDING register.

Transfers can now begin and RXREADY will now behave as expected.

**8. SPI disable does not work in SLAVE mode**

SPI disable does not work in SLAVE mode.

**Fix/Workaround**

Read the last received data, then perform a software reset by writing a one to the Software Reset bit in the Control Register (CR.SWRST).

**9. SPI data transfer hangs with CSR0.CSAAT==1 and MR.MODFDIS==0**

When CSR0.CSAAT==1 and mode fault detection is enabled (MR.MODFDIS==0), the SPI module will not start a data transfer.

**Fix/Workaround**

Disable mode fault detection by writing a one to MR.MODFDIS.

**10. Disabling SPI has no effect on the SR.TDRE bit**

Disabling SPI has no effect on the SR.TDRE bit whereas the write data command is filtered when SPI is disabled. Writing to TDR when SPI is disabled will not clear SR.TDRE. If SPI is disabled during a PDCA transfer, the PDCA will continue to write data to TDR until its buffer is empty, and this data will be lost.

**Fix/Workaround**

Disable the PDCA, add two NOPs, and disable the SPI. To continue the transfer, enable the SPI and PDCA.

**11. Power Manager****12. If the BOD level is higher than VDDCORE, the part is constantly reset**

If the BOD level is set to a value higher than VDDCORE and enabled by fuses, the part will be in constant reset.

**Fix/Workaround**

Apply an external voltage on VDDCORE that is higher than the BOD level and is lower than VDDCORE max and disable the BOD.

**3. When the main clock is RCSYS, TIMER\_CLOCK5 is equal to PBA clock**

When the main clock is generated from RCSYS, TIMER\_CLOCK5 is equal to PBA Clock and not PBA Clock / 128.

**Fix/Workaround**

None.

**13. Clock sources will not be stopped in STATIC sleep mode if the difference between CPU and PBx division factor is too high**

If the division factor between the CPU/HSB and PBx frequencies is more than 4 when going to a sleep mode where the system RC oscillator is turned off, then high speed clock sources will not be turned off. This will result in a significantly higher power consumption during the sleep mode.

**Fix/Workaround**

Before going to sleep modes where the system RC oscillator is stopped, make sure that the factor between the CPU/HSB and PBx frequencies is less than or equal to 4.

**14. Increased Power Consumption in VDDIO in sleep modes**

If the OSC0 is enabled in crystal mode when entering a sleep mode where the OSC0 is disabled, this will lead to an increased power consumption in VDDIO.

**Fix/Workaround**

Disable the OSC0 through the System Control Interface (SCIF) before going to any sleep mode where the OSC0 is disabled, or pull down or up XIN0 and XOUT0 with 1 Mohm resistor.



**15. SSC****16. Additional delay on TD output**

A delay from 2 to 3 system clock cycles is added to TD output when:

TCMR.START = Receive Start,

TCMR.STTDLY = more than ZERO,

RCMR.START = Start on falling edge / Start on Rising edge / Start on any edge,

RFMR.FSOS = None (input).

**Fix/Workaround**

None.

**17. TF output is not correct**

TF output is not correct (at least emitted one serial clock cycle later than expected) when:

TFMR.FSOS = Driven Low during data transfer/ Driven High during data transfer

TCMR.START = Receive start

RFMR.FSOS = None (Input)

RCMR.START = any on RF (edge/level)

**Fix/Workaround**

None.

**18. Frame Synchro and Frame Synchro Data are delayed by one clock cycle**

The frame synchro and the frame synchro data are delayed from 1 SSC\_CLOCK when:

- Clock is CKDIV

- The START is selected on either a frame synchro edge or a level

- Frame synchro data is enabled

- Transmit clock is gated on output (through CKO field)

**Fix/Workaround**

Transmit or receive CLOCK must not be gated (by the mean of CKO field) when START condition is performed on a generated frame synchro.

**19. USB****20. UPCFGn.INTFRQ is irrelevant for isochronous pipe**

As a consequence, isochronous IN and OUT tokens are sent every 1ms (Full Speed), or every 125uS (High Speed).

**Fix/Workaround**

For higher polling time, the software must freeze the pipe for the desired period in order to prevent any "extra" token.

- ADC

**1. Sleep Mode activation needs additional A to D conversion**

If the ADC sleep mode is activated when the ADC is idle the ADC will not enter sleep mode before after the next AD conversion.

**Fix/Workaround**

Activate the sleep mode in the mode register and then perform an AD conversion.

- PDCA

**1. Wrong PDCA behavior when using two PDCA channels with the same PID**

Wrong PDCA behavior when using two PDCA channels with the same PID.

**Fix/Workaround**

The same PID should not be assigned to more than one channel.

2. **Transfer error will stall a transmit peripheral handshake interface**  
 If a transfer error is encountered on a channel transmitting to a peripheral, the peripheral handshake of the active channel will stall and the PDCA will not do any more transfers on the affected peripheral handshake interface.  
**Fix/Workaround**  
 Disable and then enable the peripheral after the transfer error.
3. **TWI**
4. **The TWI RXRDY flag in SR register is not reset when a software reset is performed**  
 The TWI RXRDY flag in SR register is not reset when a software reset is performed.  
**Fix/Workaround**  
 After a Software Reset, the register TWI RHR must be read.
5. **TWI in master mode will continue to read data**  
 TWI in master mode will continue to read data on the line even if the shift register and the RHR register are full. This will generate an overrun error.  
**Fix/Workaround**  
 To prevent this, read the RHR register as soon as a new RX data is ready.
6. **TWI slave behaves improperly if master acknowledges the last transmitted data byte before a STOP condition**  
 In I2C slave transmitter mode, if the master acknowledges the last data byte before a STOP condition (what the master is not supposed to do), the following TWI slave receiver mode frame may contain an inappropriate clock stretch. This clock stretch can only be stopped by resetting the TWI.  
**Fix/Workaround**  
 If the TWI is used as a slave transmitter with a master that acknowledges the last data byte before a STOP condition, it is necessary to reset the TWI before entering slave receiver mode.
7. **GPIO**
8. **PA29 (TWI SDA) and PA30 (TWI SCL) GPIO VIH (input high voltage) is 3.6V max instead of 5V tolerant**  
 The following GPIOs are not 5V tolerant: PA29 and PA30.  
**Fix/Workaround**  
 None.
9. **Some GPIO VIH (input high voltage) are 3.6V max instead of 5V tolerant**  
 Only 11 GPIOs remain 5V tolerant (VIHmax=5V):PB01, PB02, PB03, PB10, PB19, PB20, PB21, PB22, PB23, PB27, PB28.  
**Fix/Workaround**  
 None.
10. **TC**
11. **Channel chaining skips first pulse for upper channel**  
 When chaining two channels using the Block Mode Register, the first pulse of the clock between the channels is skipped.  
**Fix/Workaround**  
 Configure the lower channel with RA = 0x1 and RC = 0x2 to produce a dummy clock cycle for the upper channel. After the dummy cycle has been generated, indicated by the

SR.CPCS bit, reconfigure the RA and RC registers for the lower channel with the real values.

- *OCD*

**1. The auxiliary trace does not work for CPU/HSB speed higher than 50MHz**

The auxiliary trace does not work for CPU/HSB speed higher than 50MHz.

**Fix/Workaround**

Do not use the auxiliary trace for CPU/HSB speed higher than 50MHz.

- *Processor and Architecture*

**1. LDM instruction with PC in the register list and without ++ increments Rp**

For LDM with PC in the register list: the instruction behaves as if the ++ field is always set, ie the pointer is always updated. This happens even if the ++ field is cleared. Specifically, the increment of the pointer is done in parallel with the testing of R12.

**Fix/Workaround**

None.

**2. RETE instruction does not clear SREG[L] from interrupts**

The RETE instruction clears SREG[L] as expected from exceptions.

**Fix/Workaround**

When using the STCOND instruction, clear SREG[L] in the stacked value of SR before returning from interrupts with RETE.

**3. RETS behaves incorrectly when MPU is enabled**

RETS behaves incorrectly when MPU is enabled and MPU is configured so that system stack is not readable in unprivileged mode.

**Fix/Workaround**

Make system stack readable in unprivileged mode, or return from supervisor mode using rete instead of rets. This requires:

1. Changing the mode bits from 001 to 110 before issuing the instruction. Updating the mode bits to the desired value must be done using a single mtsr instruction so it is done atomically. Even if this step is generally described as not safe in the UC technical reference manual, it is safe in this very specific case.
2. Execute the RETE instruction.

**4. Privilege violation when using interrupts in application mode with protected system stack**

If the system stack is protected by the MPU and an interrupt occurs in application mode, an MPU DTLB exception will occur.

**Fix/Workaround**

Make a DTLB Protection (Write) exception handler which permits the interrupt request to be handled in privileged mode.

**5. USART**

**6. ISO7816 info register US\_NER cannot be read**

The NER register always returns zero.

**Fix/Workaround**

None.

**7. ISO7816 Mode T1: RX impossible after any TX**

RX impossible after any TX.

**Fix/Workaround**

SOFT\_RESET on RX+ Config US\_MR + Config\_US\_CR.

**8. The RTS output does not function correctly in hardware handshaking mode**

The RTS signal is not generated properly when the USART receives data in hardware handshaking mode. When the Peripheral DMA receive buffer becomes full, the RTS output should go high, but it will stay low.

**Fix/Workaround**

Do not use the hardware handshaking mode of the USART. If it is necessary to drive the RTS output high when the Peripheral DMA receive buffer becomes full, use the normal mode of the USART. Configure the Peripheral DMA Controller to signal an interrupt when the receive buffer is full. In the interrupt handler code, write a one to the RTSDIS bit in the USART Control Register (CR). This will drive the RTS output high. After the next DMA transfer is started and a receive buffer is available, write a one to the RTSEN bit in the USART CR so that RTS will be driven low.

**9. Corruption after receiving too many bits in SPI slave mode**

If the USART is in SPI slave mode and receives too much data bits (ex: 9bits instead of 8 bits) by the SPI master, an error occurs. After that, the next reception may be corrupted even if the frame is correct and the USART has been disabled, reset by a soft reset and re-enabled.

**Fix/Workaround**

None.

**10. USART slave synchronous mode external clock must be at least 9 times lower in frequency than CLK\_USART**

When the USART is operating in slave synchronous mode with an external clock, the frequency of the signal provided on CLK must be at least 9 times lower than CLK\_USART.

**Fix/Workaround**

When the USART is operating in slave synchronous mode with an external clock, provide a signal on CLK that has a frequency at least 9 times lower than CLK\_USART.

**11. HMATRIX****12. In the PRAS and PRBS registers, the MxPR fields are only two bits**

In the PRAS and PRBS registers, the MxPR fields are only two bits wide, instead of four bits. The unused bits are undefined when reading the registers.

**Fix/Workaround**

Mask undefined bits when reading PRAS and PRBS.

**- FLASHC****1. Reading from on-chip flash may fail after a flash fuse write operation (FLASHC LP, UP, WGPB, EGPB, SSB, PGPFB, EAGPF commands).**

After a flash fuse write operation (FLASHC LP, UP, WGPB, EGPB, SSB, PGPFB, EAGPF commands), the following flash read access may return corrupted data. This erratum does not affect write operations to regular flash memory.

**Fix/Workaround**

The flash fuse write operation (FLASHC LP, UP, WGPB, EGPB, SSB, PGPFB, EAGPF commands) must be issued from internal RAM. After the write operation, perform a dummy flash page write operation (FLASHC WP). Content and location of this page is not important

and filling the write buffer with all one (FFh) will leave the current flash content unchanged. It is then safe to read and fetch code from the flash.

- *DSP Operations*

**1. Hardware breakpoints may corrupt MAC results**

Hardware breakpoints on MAC instructions may corrupt the destination register of the MAC instruction.

**Fix/Workaround**

Place breakpoints on earlier or later instructions.

## 12.2.4 Rev. B

## - PWM

- 1. PWM channel interrupt enabling triggers an interrupt**

When enabling a PWM channel that is configured with center aligned period (CALG=1), an interrupt is signalled.

**Fix/Workaround**  
When using center aligned mode, enable the channel and read the status before channel interrupt is enabled.
- 2. PWN counter restarts at 0x0001**

The PWM counter restarts at 0x0001 and not 0x0000 as specified. Because of this the first PWM period has one more clock cycle.

**Fix/Workaround**

  - The first period is 0x0000, 0x0001, ..., period.
  - Consecutive periods are 0x0001, 0x0002, ..., period.
- 3. PWM update period to a 0 value does not work**

It is impossible to update a period equal to 0 by the using the PWM update register (PWM\_CUPD).

**Fix/Workaround**  
Do not update the PWM\_CUPD register with a value equal to 0.
- 4. PWM channel status may be wrong if disabled before a period has elapsed**

Before a PWM period has elapsed, the read channel status may be wrong. The CHIDx-bit for a PWM channel in the PWM Enable Register will read '1' for one full PWM period even if the channel was disabled before the period elapsed. It will then read '0' as expected.

**Fix/Workaround**  
Reading the PWM channel status of a disabled channel is only correct after a PWM period has elapsed.
- 5. The following alternate C functions PWM[4] on PA16 and PWM[6] on PA31 are not available on Rev B**

The following alternate C functions PWM[4] on PA16 and PWM[6] on PA31 are not available on Rev B.

**Fix/Workaround**  
Do not use these PWM alternate functions on these pins.
- 6. SPI**
- 7. SPI Slave / PDCA transfer: no TX UNDERRUN flag**

There is no TX UNDERRUN flag available, therefore in SPI slave mode, there is no way to be informed of a character lost in transmission.

**Fix/Workaround**  
For PDCA transfer: none.

**8. SPI bad serial clock generation on 2nd chip\_select when SCBR=1, CPOL=1, and NCPHA=0**

When multiple chip selects (CS) are in use, if one of the baudrates equal 1 while one (CSRn.SCBR=1) of the others do not equal 1, and CSRn.CPOL=1 and CSRn.NCPHA=0, then an additional pulse will be generated on SCK.

**Fix/Workaround**

When multiple CS are in use, if one of the baudrates equals 1, the others must also equal 1 if CSRn.CPOL=1 and CSRn.NCPHA=0.

**9. SPI Glitch on RXREADY flag in slave mode when enabling the SPI or during the first transfer**

In slave mode, the SPI can generate a false RXREADY signal during enabling of the SPI or during the first transfer.

**Fix/Workaround**

1. Set slave mode, set required CPOL/CPHA.
2. Enable SPI.
3. Set the polarity CPOL of the line in the opposite value of the required one.
4. Set the polarity CPOL to the required one.
5. Read the RXHOLDING register.

Transfers can now begin and RXREADY will now behave as expected.

**10. SPI CSNAAT bit 2 in register CSR0...CSR3 is not available**

SPI CSNAAT bit 2 in register CSR0...CSR3 is not available.

**Fix/Workaround**

Do not use this bit.

**11. SPI disable does not work in SLAVE mode**

SPI disable does not work in SLAVE mode.

**Fix/Workaround**

Read the last received data, then perform a software reset by writing a one to the Software Reset bit in the Control Register (CR.SWRST).

*- Power Manager*

**1. PLL Lock control does not work**

PLL lock Control does not work.

**Fix/Workaround**

In PLL Control register, the bit 7 should be set in order to prevent unexpected behavior.

**2. Wrong reset causes when BOD is activated**

Setting the BOD enable fuse will cause the Reset Cause Register to list BOD reset as the reset source even though the part was reset by another source.

**Fix/Workaround**

Do not set the BOD enable fuse, but activate the BOD as soon as your program starts.

**3. System Timer mask (Bit 16) of the PM CPUMASK register is not available**

System Timer mask (Bit 16) of the PM CPUMASK register is not available.

**Fix/Workaround**

Do not use this bit.

## - SSC

1. **SSC does not trigger RF when data is low**

The SSC cannot transmit or receive data when CKS = CKDIV and CKO = none, in TCMR or RCMR respectively.

**Fix/Workaround**

Set CKO to a value that is not "none" and bypass the output of the TK/RK pin with the GPIO.

## - USB

1. **USB No end of host reset signaled upon disconnection**

In host mode, in case of an unexpected device disconnection whereas a usb reset is being sent by the usb controller, the UHCON.RESET bit may not be cleared by the hardware at the end of the reset.

**Fix/Workaround**

A software workaround consists in testing (by polling or interrupt) the disconnection (UHINT.DDISCI == 1) while waiting for the end of reset (UHCON.RESET == 0) to avoid being stuck.

2. **USBFSM and UHADDR1/2/3 registers are not available**

Do not use USBFSM register.

**Fix/Workaround**

Do not use USBFSM register and use HCON[6:0] field instead for all the pipes.

## - Cycle counter

1. **CPU Cycle Counter does not reset the COUNT system register on COMPARE match.**

The device revision B does not reset the COUNT system register on COMPARE match. In this revision, the COUNT register is clocked by the CPU clock, so when the CPU clock stops, so does incrementing of COUNT.

**Fix/Workaround**

None.

## - ADC

1. **ADC possible miss on DRDY when disabling a channel**

The ADC does not work properly when more than one channel is enabled.

**Fix/Workaround**

Do not use the ADC with more than one channel enabled at a time.

2. **ADC OVRE flag sometimes not reset on Status Register read**

The OVRE flag does not clear properly if read simultaneously to an end of conversion.

**Fix/Workaround**

None.

3. **Sleep Mode activation needs additional A to D conversion**

If the ADC sleep mode is activated when the ADC is idle the ADC will not enter sleep mode before after the next AD conversion.

**Fix/Workaround**

Activate the sleep mode in the mode register and then perform an AD conversion.



- *USART*

1. **USART Manchester Encoder Not Working**  
Manchester encoding/decoding is not working.  
**Fix/Workaround**  
Do not use manchester encoding.
2. **USART RXBREAK problem when no timeguard**  
In asynchronous mode the RXBREAK flag is not correctly handled when the timeguard is 0 and the break character is located just after the stop bit.  
**Fix/Workaround**  
If the NBSTOP is 1, timeguard should be different from 0.
3. **USART Handshaking: 2 characters sent / CTS rises when TX**  
If CTS switches from 0 to 1 during the TX of a character, if the Holding register is not empty, the TXHOLDING is also transmitted.  
**Fix/Workaround**  
None.
4. **USART PDC and TIMEGUARD not supported in MANCHESTER**  
Manchester encoding/decoding is not working.  
**Fix/Workaround**  
Do not use manchester encoding.
5. **USART SPI mode is non functional on this revision**  
USART SPI mode is non functional on this revision.  
**Fix/Workaround**  
Do not use the USART SPI mode.

- *HMATRIX*

1. **HMatrix fixed priority arbitration does not work**  
Fixed priority arbitration does not work.  
**Fix/Workaround**  
Use Round-Robin arbitration instead.

- *Clock characteristic*

1. **PBA max frequency**  
The Peripheral bus A (PBA) max frequency is 30MHz instead of 60MHz.  
**Fix/Workaround**  
Do not set the PBA maximum frequency higher than 30MHz.

- *FLASHC*

1. **The address of Flash General Purpose Fuse Register Low (FGPFRLO) is 0xFFFE140C on revB instead of 0xFFFE1410**  
The address of Flash General Purpose Fuse Register Low (FGPFRLO) is 0xFFFE140C on revB instead of 0xFFFE1410.  
**Fix/Workaround**  
None.

2. **The command Quick Page Read User Page(QPRUP) is not functional**  
 The command Quick Page Read User Page(QPRUP) is not functional.  
**Fix/Workaround**  
 None.
  
3. **PAGEN Semantic Field for Program GP Fuse Byte is WriteData[7:0], ByteAddress[1:0] on revision B instead of WriteData[7:0], ByteAddress[2:0]**  
 PAGEN Semantic Field for Program GP Fuse Byte is WriteData[7:0], ByteAddress[1:0] on revision B instead of WriteData[7:0], ByteAddress[2:0].  
**Fix/Workaround**  
 None.
  
4. **Reading from on-chip flash may fail after a flash fuse write operation (FLASHC LP, UP, WGPB, EGPB, SSB, PGPFB, EAGPF commands).**  
 After a flash fuse write operation (FLASHC LP, UP, WGPB, EGPB, SSB, PGPFB, EAGPF commands), the following flash read access may return corrupted data. This erratum does not affect write operations to regular flash memory.  
**Fix/Workaround**  
 The flash fuse write operation (FLASHC LP, UP, WGPB, EGPB, SSB, PGPFB, EAGPF commands) must be issued from internal RAM. After the write operation, perform a dummy flash page write operation (FLASHC WP). Content and location of this page is not important and filling the write buffer with all one (FFh) will leave the current flash content unchanged. It is then safe to read and fetch code from the flash.
  
- 5.

- RTC

1. **Writes to control (CTRL), top (TOP) and value (VAL) in the RTC are discarded if the RTC peripheral bus clock (PBA) is divided by a factor of four or more relative to the HSB clock**  
 Writes to control (CTRL), top (TOP) and value (VAL) in the RTC are discarded if the RTC peripheral bus clock (PBA) is divided by a factor of four or more relative to the HSB clock.  
**Fix/Workaround**  
 Do not write to the RTC registers using the peripheral bus clock (PBA) divided by a factor of four or more relative to the HSB clock.
  
2. **The RTC CLKEN bit (bit number 16) of CTRL register is not available**  
 The RTC CLKEN bit (bit number 16) of CTRL register is not available.  
**Fix/Workaround**  
 Do not use the CLKEN bit of the RTC on Rev B.

## - OCD

**1. Stalled memory access instruction writeback fails if followed by a HW breakpoint**

Consider the following assembly code sequence:

A

B

If a hardware breakpoint is placed on instruction B, and instruction A is a memory access instruction, register file updates from instruction A can be discarded.

**Fix/Workaround**

Do not place hardware breakpoints, use software breakpoints instead. Alternatively, place a hardware breakpoint on the instruction before the memory access instruction and then single step over the memory access instruction.

## - Processor and Architecture

**1. Local Bus to fast GPIO not available on silicon Rev B**

Local bus is only available for silicon RevE and later.

**Fix/Workaround**

Do not use if silicon revision older than F.

**2. Memory Protection Unit (MPU) is non functional**

Memory Protection Unit (MPU) is non functional.

**Fix/Workaround**

Do not use the MPU.

**3. Bus error should be masked in Debug mode**

If a bus error occurs during debug mode, the processor will not respond to debug commands through the DINST register.

**Fix/Workaround**

A reset of the device will make the CPU respond to debug commands again.

**4. Read Modify Write (RMW) instructions on data outside the internal RAM does not work**

Read Modify Write (RMW) instructions on data outside the internal RAM does not work.

**Fix/Workaround**

Do not perform RMW instructions on data outside the internal RAM.

**5. Need two NOPs instruction after instructions masking interrupts**

The instructions following in the pipeline the instruction masking the interrupt through SR may behave abnormally.

**Fix/Workaround**

Place two NOPs instructions after each SSRF or MTSR instruction setting IxM or GM in SR

**6. Clock connection table on Rev B**

Here is the table of Rev B

**Figure 12-1.** Timer/Counter clock connections on RevB

Source	Name	Connection
Internal	TIMER_CLOCK1	32KHz Oscillator
	TIMER_CLOCK2	PBA Clock / 4
	TIMER_CLOCK3	PBA Clock / 8
	TIMER_CLOCK4	PBA Clock / 16
	TIMER_CLOCK5	PBA Clock / 32
External	XC0	
	XC1	
	XC2	

**7. Spurious interrupt may corrupt core SR mode to exception**

If the rules listed in the chapter 'Masking interrupt requests in peripheral modules' of the AVR32UC Technical Reference Manual are not followed, a spurious interrupt may occur. An interrupt context will be pushed onto the stack while the core SR mode will indicate an exception. A RETE instruction would then corrupt the stack.

**Fix/Workaround**

Follow the rules of the AVR32UC Technical Reference Manual. To increase software robustness, if an exception mode is detected at the beginning of an interrupt handler, change the stack interrupt context to an exception context and issue a RETE instruction.

**8. CPU cannot operate on a divided slow clock (internal RC oscillator)**

CPU cannot operate on a divided slow clock (internal RC oscillator).

**Fix/Workaround**

Do not run the CPU on a divided slow clock.

**9. LDM instruction with PC in the register list and without ++ increments Rp**

For LDM with PC in the register list: the instruction behaves as if the ++ field is always set, i.e. the pointer is always updated. This happens even if the ++ field is cleared. Specifically, the increment of the pointer is done in parallel with the testing of R12.

**Fix/Workaround**

None.

**10. RETE instruction does not clear SREG[L] from interrupts**

The RETE instruction clears SREG[L] as expected from exceptions.

**Fix/Workaround**

When using the STCOND instruction, clear SREG[L] in the stacked value of SR before returning from interrupts with RETE.

**11. Exceptions when system stack is protected by MPU**

RETS behaves incorrectly when MPU is enabled and MPU is configured so that system stack is not readable in unprivileged mode.

**Fix/Workaround**

Workaround 1: Make system stack readable in unprivileged mode,

or

Workaround 2: Return from supervisor mode using rete instead of rets. This requires: 1. Changing the mode bits from 001b to 110b before issuing the instruction.

Updating the mode bits to the desired value must be done using a single mtsr instruction so

it is done atomically. Even if this step is described in general as not safe in the UC technical reference guide, it is safe in this very specific case.

2. Execute the RETE instruction.

## 13. Datasheet Revision History

Please note that the referring page numbers in this section are referred to this document. The referring revision in this section are referring to the document revision.

### 13.1 Rev. L– 01/2012

1. Updated Mechanical Characteristics section.

### 13.2 Rev. K– 02/2011

1. Updated USB section.
2. Updated Configuration Summary section.
3. Updated Electrical Characteristics section.
4. Updated Errata section.

### 13.3 Rev. J– 12/2010

1. Updated USB section.
2. Updated USART section.
3. Updated TWI section.
4. Updated PWM section.
5. Updated Electrical Characteristics section.

### 13.4 Rev. I – 06/2010

1. Updated SPI section.
2. Updated Electrical Characteristics section.

### 13.5 Rev. H – 10/2009

1. Update datasheet architecture.
2. Add AT32UC3B0512 and AT32UC3B1512 devices description.

**13.6 Rev. G – 06/2009**

1. Open Drain Mode removed from GPIO section.
2. Updated Errata section.

**13.7 Rev. F – 04/2008**

1. Updated Errata section.

**13.8 Rev. E – 12/2007**

1. Updated Memory Protection section.

**13.9 Rev. D – 11/2007**

1. Updated Processor Architecture section.
2. Updated Electrical Characteristics section.

**13.10 Rev. C – 10/2007**

1. Updated Features sections.
2. Updated block diagram with local bus figure
3. Add schematic for HMatrix master/slave connection.
4. Updated Features sections with local bus.
5. Added SPI feature to USART section.
6. Updated USBB section.
7. Updated ADC trigger selection in ADC section.
8. Updated JTAG and Boundary Scan section with programming procedure.
9. Add description for silicon revision D

**13.11 Rev. B – 07/2007**

1. Updated registered trademarks
2. Updated address page.

**13.12 Rev. A – 05/2007**

1. Initial revision.



**Table of Contents**

**1 Description ..... 3**

**2 Overview ..... 4**

    2.1 Blockdiagram ..... 4

**3 Configuration Summary ..... 5**

**4 Package and Pinout ..... 6**

    4.1 Package ..... 6

    4.2 Peripheral Multiplexing on I/O lines ..... 7

    4.3 High Drive Current GPIO ..... 10

**5 Signals Description ..... 10**

    5.1 JTAG pins ..... 13

    5.2 RESET\_N pin ..... 14

    5.3 TWI pins ..... 14

    5.4 GPIO pins ..... 14

    5.5 High drive pins ..... 14

    5.6 Power Considerations ..... 14

**6 Processor and Architecture ..... 17**

    6.1 Features ..... 17

    6.2 AVR32 Architecture ..... 17

    6.3 The AVR32UC CPU ..... 18

    6.4 Programming Model ..... 22

    6.5 Exceptions and Interrupts ..... 26

    6.6 Module Configuration ..... 30

**7 Memories ..... 31**

    7.1 Embedded Memories ..... 31

    7.2 Physical Memory Map ..... 31

    7.3 Peripheral Address Map ..... 32

    7.4 CPU Local Bus Mapping ..... 33

**8 Boot Sequence ..... 34**

    8.1 Starting of clocks ..... 34

    8.2 Fetching of initial instructions ..... 34

**9 Electrical Characteristics ..... 35**

    9.1 Absolute Maximum Ratings\* ..... 35



9.2	DC Characteristics .....	36
9.3	Regulator Characteristics .....	38
9.4	Analog Characteristics .....	38
9.5	Power Consumption .....	42
9.6	System Clock Characteristics .....	45
9.7	Oscillator Characteristics .....	46
9.8	ADC Characteristics .....	48
9.9	USB Transceiver Characteristics .....	50
9.10	JTAG Characteristics .....	51
9.11	SPI Characteristics .....	52
9.12	Flash Memory Characteristics .....	54
<b>10</b>	<b><i>Mechanical Characteristics</i></b> .....	<b>55</b>
10.1	Thermal Considerations .....	55
10.2	Package Drawings .....	56
10.3	Soldering Profile .....	60
<b>11</b>	<b><i>Ordering Information</i></b> .....	<b>61</b>
<b>12</b>	<b><i>Errata</i></b> .....	<b>62</b>
12.1	AT32UC3B0512, AT32UC3B1512 .....	62
12.2	AT32UC3B0256, AT32UC3B0128, AT32UC3B064, AT32UC3B1256, AT32UC3B1128, AT32UC3B164 74	
<b>13</b>	<b><i>Datasheet Revision History</i></b> .....	<b>102</b>
13.1	Rev. L– 01/2012 .....	102
13.2	Rev. K– 02/2011 .....	102
13.3	Rev. J– 12/2010 .....	102
13.4	Rev. I – 06/2010 .....	102
13.5	Rev. H – 10/2009 .....	102
13.6	Rev. G – 06/2009 .....	103
13.7	Rev. F – 04/2008 .....	103
13.8	Rev. E – 12/2007 .....	103
13.9	Rev. D – 11/2007 .....	103
13.10	Rev. C – 10/2007 .....	103
13.11	Rev. B – 07/2007 .....	103
13.12	Rev. A – 05/2007 .....	104

**Atmel Corporation**

2325 Orchard Parkway  
San Jose, CA 95131  
USA

**Tel:** (+1)(408) 441-0311

**Fax:** (+1)(408) 487-2600

[www.atmel.com](http://www.atmel.com)

**Atmel Asia Limited**

Unit 1-5 & 16, 19/F  
BEA Tower, Millennium City 5  
418 Kwun Tong Road  
Kwun Tong, Kowloon  
HONG KONG

**Tel:** (+852) 2245-6100

**Fax:** (+852) 2722-1369

**Atmel Munich GmbH**

Business Campus  
Parking 4  
D-85748 Garching b. Munich  
GERMANY

**Tel:** (+49) 89-31970-0

**Fax:** (+49) 89-3194621

**Atmel Japan**

16F, Shin Osaki Kangyo Bldg.  
1-6-4 Osaka Shinagawa-ku  
Tokyo 104-0032

JAPAN

**Tel:** (+81) 3-6417-0300

**Fax:** (+81) 3-6417-0370

© 2012 Atmel Corporation. All rights reserved.

Atmel®, Atmel logo and combinations thereof AVR®, Qtouch®, Adjacent Key Suppression®, AKS®, and others are registered trademarks or trademarks of Atmel Corporation or its subsidiaries. Other terms and product names may be trademarks of others.

**Disclaimer:** The information in this document is provided in connection with Atmel products. No license, express or implied, by estoppel or otherwise, to any intellectual property right is granted by this document or in connection with the sale of Atmel products. **EXCEPT AS SET FORTH IN THE ATMEL TERMS AND CONDITIONS OF SALES LOCATED ON THE ATMEL WEBSITE, ATMEL ASSUMES NO LIABILITY WHATSOEVER AND DISCLAIMS ANY EXPRESS, IMPLIED OR STATUTORY WARRANTY RELATING TO ITS PRODUCTS INCLUDING, BUT NOT LIMITED TO, THE IMPLIED WARRANTY OF MERCHANTABILITY, FITNESS FOR A PARTICULAR PURPOSE, OR NON-INFRINGEMENT. IN NO EVENT SHALL ATMEL BE LIABLE FOR ANY DIRECT, INDIRECT, CONSEQUENTIAL, PUNITIVE, SPECIAL OR INCIDENTAL DAMAGES (INCLUDING, WITHOUT LIMITATION, DAMAGES FOR LOSS AND PROFITS, BUSINESS INTERRUPTION, OR LOSS OF INFORMATION) ARISING OUT OF THE USE OR INABILITY TO USE THIS DOCUMENT, EVEN IF ATMEL HAS BEEN ADVISED OF THE POSSIBILITY OF SUCH DAMAGES.** Atmel makes no representations or warranties with respect to the accuracy or completeness of the contents of this document and reserves the right to make changes to specifications and product descriptions at any time without notice. Atmel does not make any commitment to update the information contained herein. Unless specifically provided otherwise, Atmel products are not suitable for, and shall not be used in, automotive applications. Atmel products are not intended, authorized, or warranted for use as components in applications intended to support or sustain life.