

# MC100LVEL31

## 3.3 V ECL D Flip-Flop with Set and Reset

### Description

The MC100LVEL31 is a D flip-flop with set and reset. The device is functionally equivalent to the EL31 device but operates from a 3.3 V supply. With propagation delays and output transition times essentially equivalent to the EL31, the LVEL31 is ideally suited for those applications which require the ultimate in AC performance at low power supply voltages.

Both set and reset inputs are asynchronous, level triggered signals. Data enters the master portion of the flip-flop when clock is LOW and is transferred to the slave, and thus the outputs, upon a positive transition of the clock.

### Features

- 475 ps Typical Propagation Delay
- 2.9 GHz Toggle Frequency
- ESD Protection:
  - ◆ > 4 kV Human Body Model
  - ◆ > 200 V Machine Model
- The 100 Series Contains Temperature Compensation
- PECL Mode Operating Range:  $V_{CC} = 3.0\text{ V}$  to  $3.8\text{ V}$  with  $V_{EE} = 0\text{ V}$
- NECL Mode Operating Range:  $V_{CC} = 0\text{ V}$  with  $V_{EE} = -3.0\text{ V}$  to  $-3.8\text{ V}$
- Internal Input Pulldown Resistors
- Meets or Exceeds JEDEC Spec EIA/JESD78 IC Latchup Test
- Moisture Sensitivity:
  - ◆ Level 1 for SOIC-8
  - ◆ Level 3 for TSSOP-8
  - ◆ For Additional Information, see Application Note [AND8003/D](#)
- Flammability Rating: UL 94 V-0 @ 0.125 in, Oxygen Index: 28 to 34
- Transistor Count = 121 Devices
- These Devices are Pb-Free, Halogen Free and are RoHS Compliant



**ON Semiconductor®**

[www.onsemi.com](http://www.onsemi.com)



SOIC-8 NB  
D SUFFIX  
CASE 751-07



TSSOP-8  
DT SUFFIX  
CASE 948R-02

### MARKING DIAGRAMS\*

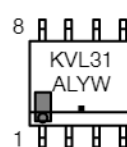

SOIC-8 NB

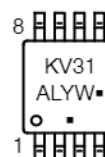

TSSOP-8

A = Assembly Location  
L = Wafer Lot  
Y = Year  
W = Work Week  
M = Date Code  
■ = Pb-Free Package

(Note: Microdot may be in either location)

\*For additional marking information, refer to Application Note [AND8002/D](#).

### ORDERING INFORMATION

Device	Package	Shipping†
MC100LVEL31DG	SOIC-8 NB (Pb-Free)	98 Units / Tube
MC100LVEL31DR2G	SOIC-8 NB (Pb-Free)	2500 Tape & Reel
MC100LVEL31DTG	TSSOP-8 (Pb-Free)	100 Units / Tube
MC100LVEL31DTR2G	TSSOP-8 (Pb-Free)	2500 Tape & Reel

†For information on tape and reel specifications, including part orientation and tape sizes, please refer to our Tape and Reel Packaging Specifications Brochure, [BRD8011/D](#).

# MC100LVEL31

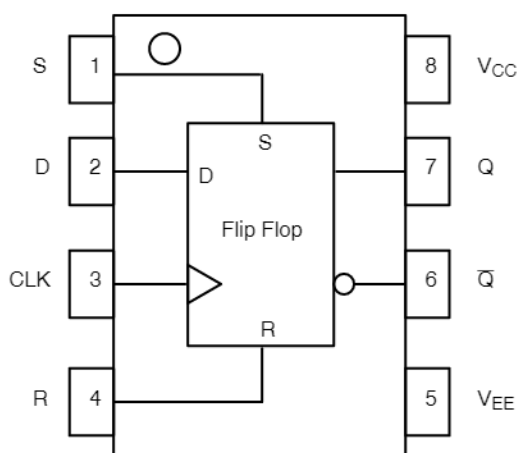

Figure 1. Logic Diagram and Pinout Assignment

Table 1. PIN DESCRIPTION

PIN	FUNCTION
CLK	ECL Clock Input
Q, $\bar{Q}$	ECL Differential Data Outputs
D	ECL Data Input
R	ECL Reset Input
S	ECL Set Input
$V_{CC}$	Positive Supply
$V_{EE}$	Negative Supply

Table 2. TRUTH TABLE

D	S	R	CLK	Q	$\bar{Q}$
L	L	L	Z	L	H
H	L	L	Z	H	L
X	H	L	X	H	L
X	L	H	X	L	H
X	H	H	X	Undef	Undef

Z = LOW to HIGH Transition  
X = Don't Care

Table 3. MAXIMUM RATINGS

Symbol	Parameter	Condition 1	Condition 2	Rating	Unit
$V_{CC}$	PECL Mode Power Supply	$V_{EE} = 0\text{ V}$		8 to 0	V
$V_{EE}$	NECL Mode Power Supply	$V_{CC} = 0\text{ V}$		-8 to 0	V
$V_I$	PECL Mode Input Voltage NECL Mode Input Voltage	$V_{EE} = 0\text{ V}$ $V_{CC} = 0\text{ V}$	$V_I \leq V_{CC}$ $V_I \geq V_{EE}$	6 to 0 -6 to 0	V
$I_{out}$	Output Current	Continuous Surge		50 100	mA
$T_A$	Operating Temperature Range			-40 to +85	°C
$T_{stg}$	Storage Temperature Range			-65 to +150	°C
$\theta_{JA}$	Thermal Resistance (Junction-to-Ambient)	0 lfpm 500 lfpm	SOIC-8 NB SOIC-8 NB	190 130	°C/W
$\theta_{JC}$	Thermal Resistance (Junction-to-Case)	Standard Board	SOIC-8 NB	41 to 44 ±5%	°C/W
$\theta_{JA}$	Thermal Resistance (Junction-to-Ambient)	0 lfpm 500 lfpm	TSSOP-8 TSSOP-8	185 140	°C/W
$\theta_{JC}$	Thermal Resistance (Junction-to-Case)	Standard Board	TSSOP-8	41 to 44 ±5%	°C/W
$T_{sol}$	Wave Solder (Pb-Free)	< 2 to 3 sec @ 260°C		265	°C

Stresses exceeding those listed in the Maximum Ratings table may damage the device. If any of these limits are exceeded, device functionality should not be assumed, damage may occur and reliability may be affected.

# MC100LEVEL31

**Table 4. LVPECL DC CHARACTERISTICS** ( $V_{CC} = 3.3\text{ V}$ ;  $V_{EE} = 0.0\text{ V}$  (Note 1))

Symbol	Characteristic	-40°C			25°C			85°C			Unit
		Min	Typ	Max	Min	Typ	Max	Min	Typ	Max	
$I_{EE}$	Power Supply Current		30	35		30	35		32	38	mA
$V_{OH}$	Output HIGH Voltage (Note 2)	2215	2295	2420	2275	2345	2420	2275	2345	2420	mV
$V_{OL}$	Output LOW Voltage (Note 2)	1470	1605	1745	1490	1595	1680	1490	1595	1680	mV
$V_{IH}$	Input HIGH Voltage	2135		2420	2135		2420	2135		2420	mV
$V_{IL}$	Input LOW Voltage	1490		1825	1490		1825	1490		1825	mV
$I_{IH}$	Input HIGH Current			150			150			150	$\mu\text{A}$
$I_{IL}$	Input LOW Current	0.5			0.5			0.5			$\mu\text{A}$

NOTE: Device will meet the specifications after thermal equilibrium has been established when mounted in a test socket or printed circuit board with maintained transverse airflow greater than 500 lpm. Electrical parameters are guaranteed only over the declared operating temperature range. Functional operation of the device exceeding these conditions is not implied. Device specification limit values are applied individually under normal operating conditions and not valid simultaneously.

1. Input and output parameters vary 1:1 with  $V_{CC}$ .  $V_{EE}$  can vary  $\pm 0.3\text{ V}$ .
2. Outputs are terminated through a  $50\ \Omega$  resistor to  $V_{CC} - 2.0\text{ V}$ .

**Table 5. LVNECL DC CHARACTERISTICS** ( $V_{CC} = 0.0\text{ V}$ ;  $V_{EE} = -3.3\text{ V}$  (Note 1))

Symbol	Characteristic	-40°C			25°C			85°C			Unit
		Min	Typ	Max	Min	Typ	Max	Min	Typ	Max	
$I_{EE}$	Power Supply Current		30	35		30	35		32	38	mA
$V_{OH}$	Output HIGH Voltage (Note 2)	-1085	-1005	-880	-1025	-955	-880	-1025	-955	-880	mV
$V_{OL}$	Output LOW Voltage (Note 2)	-1830	-1695	-1555	-1810	-1705	-1620	-1810	-1705	-1620	mV
$V_{IH}$	Input HIGH Voltage	-1165		-880	-1165		-880	-1165		-880	mV
$V_{IL}$	Input LOW Voltage	-1810		-1475	-1810		-1475	-1810		-1475	mV
$I_{IH}$	Input HIGH Current			150			150			150	$\mu\text{A}$
$I_{IL}$	Input LOW Current	0.5			0.5			0.5			$\mu\text{A}$

NOTE: Device will meet the specifications after thermal equilibrium has been established when mounted in a test socket or printed circuit board with maintained transverse airflow greater than 500 lpm. Electrical parameters are guaranteed only over the declared operating temperature range. Functional operation of the device exceeding these conditions is not implied. Device specification limit values are applied individually under normal operating conditions and not valid simultaneously.

1. Input and output parameters vary 1:1 with  $V_{CC}$ .  $V_{EE}$  can vary  $\pm 0.3\text{ V}$ .
2. Outputs are terminated through a  $50\ \Omega$  resistor to  $V_{CC} - 2.0\text{ V}$ .

# MC100LVEL31

**Table 6. AC CHARACTERISTICS** ( $V_{CC} = 3.3\text{ V}$ ;  $V_{EE} = 0.0\text{ V}$  or  $V_{CC} = 0.0\text{ V}$ ;  $V_{EE} = -3.3\text{ V}$  (Note 1))

Symbol	Characteristic	-40°C			25°C			85°C			Unit
		Min	Typ	Max	Min	Typ	Max	Min	Typ	Max	
$f_{max}$	Maximum Toggle Frequency	2.7			2.9			2.9			GHz
$t_{PLH}$ $t_{PHL}$	Propagation Delay to Output CLK S, R	365 385	465 475	580 620	375 395	475 485	590 630	415 435	530 525	630 670	ps
$t_S$ $t_H$	Setup Time Hold Time	150 250	0 100		150 250	0 100		150 250	0 100		ps
$t_{RR}$	Set/Reset Recovery	400	200		400	200		400	200		ps
$t_{JITTER}$	Cycle-to-Cycle Jitter		TBD			TBD			TBD		ps
$t_{PW}$	Minimum Pulse Width CLK Set, Reset	340 600			340 600			340 600			ps
$t_r$ $t_f$	Output Rise / Fall Times Q (20%–80%)	120	220	320	120	220	320	120	220	320	ps

NOTE: Device will meet the specifications after thermal equilibrium has been established when mounted in a test socket or printed circuit board with maintained transverse airflow greater than 500 lfm. Electrical parameters are guaranteed only over the declared operating temperature range. Functional operation of the device exceeding these conditions is not implied. Device specification limit values are applied individually under normal operating conditions and not valid simultaneously.

- $V_{EE}$  can vary  $\pm 0.3\text{ V}$ .

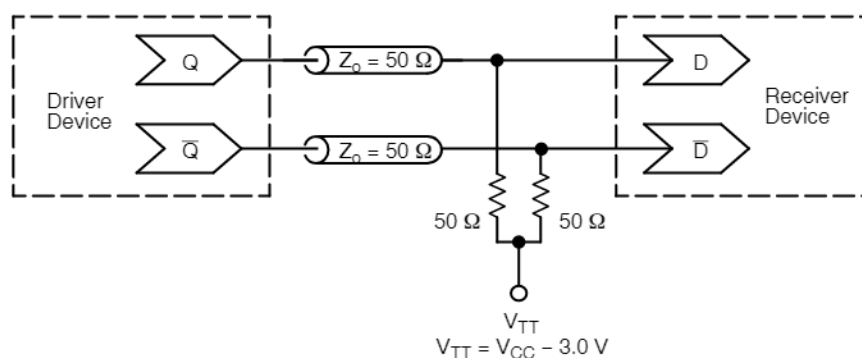

**Figure 2. Typical Termination for Output Driver and Device Evaluation**  
(See Application Note [AND8020/D](#) – Termination of ECL Logic Devices)

### Resource Reference of Application Notes

- AN1405/D** – ECL Clock Distribution Techniques
- AN1406/D** – Designing with PECL (ECL at +5.0 V)
- AN1503/D** – ECLinPS™ I/O SPICE Modeling Kit
- AN1504/D** – Metastability and the ECLinPS Family
- AN1568/D** – Interfacing Between LVDS and ECL
- AN1672/D** – The ECL Translator Guide
- AND8001/D** – Odd Number Counters Design
- AND8002/D** – Marking and Date Codes
- AND8020/D** – Termination of ECL Logic Devices
- AND8066/D** – Interfacing with ECLinPS
- AND8090/D** – AC Characteristics of ECL Devices

# MC100LVEL31

## PACKAGE DIMENSIONS

SOIC-8 NB  
D SUFFIX  
CASE 751-07  
ISSUE AK

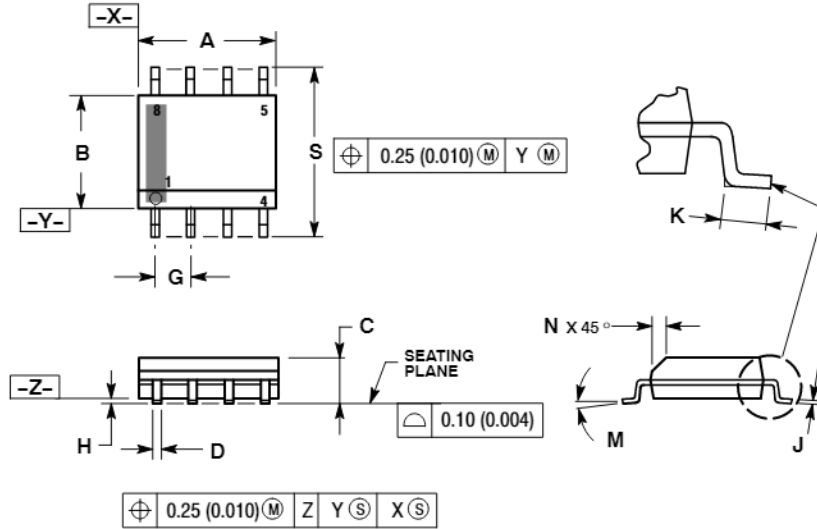

NOTES:

1. DIMENSIONING AND TOLERANCING PER ANSI Y14.5M, 1982.
2. CONTROLLING DIMENSION: MILLIMETER.
3. DIMENSION A AND B DO NOT INCLUDE MOLD PROTRUSION.
4. MAXIMUM MOLD PROTRUSION 0.15 (0.006) PER SIDE.
5. DIMENSION D DOES NOT INCLUDE DAMBAR PROTRUSION. ALLOWABLE DAMBAR PROTRUSION SHALL BE 0.127 (0.005) TOTAL IN EXCESS OF THE D DIMENSION AT MAXIMUM MATERIAL CONDITION.
6. 751-01 THRU 751-06 ARE OBSOLETE. NEW STANDARD IS 751-07.

DIM	MILLIMETERS		INCHES	
	MIN	MAX	MIN	MAX
A	4.80	5.00	0.189	0.197
B	3.80	4.00	0.150	0.157
C	1.35	1.75	0.053	0.069
D	0.33	0.51	0.013	0.020
G	1.27 BSC		0.050 BSC	
H	0.10	0.25	0.004	0.010
J	0.19	0.25	0.007	0.010
K	0.40	1.27	0.016	0.050
M	0°	8°	0°	8°
N	0.25	0.50	0.010	0.020
S	5.80	6.20	0.228	0.244

### SOLDERING FOOTPRINT\*

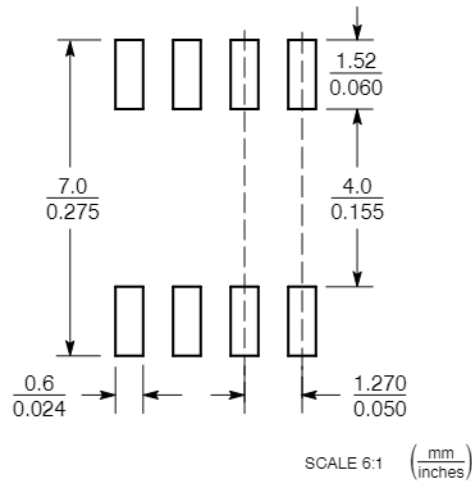

\*For additional information on our Pb-Free strategy and soldering details, please download the ON Semiconductor Soldering and Mounting Techniques Reference Manual, SOLDERRM/D.

# MC100LVEL31

## PACKAGE DIMENSIONS

TSSOP-8  
DT SUFFIX  
CASE 948R-02  
ISSUE A

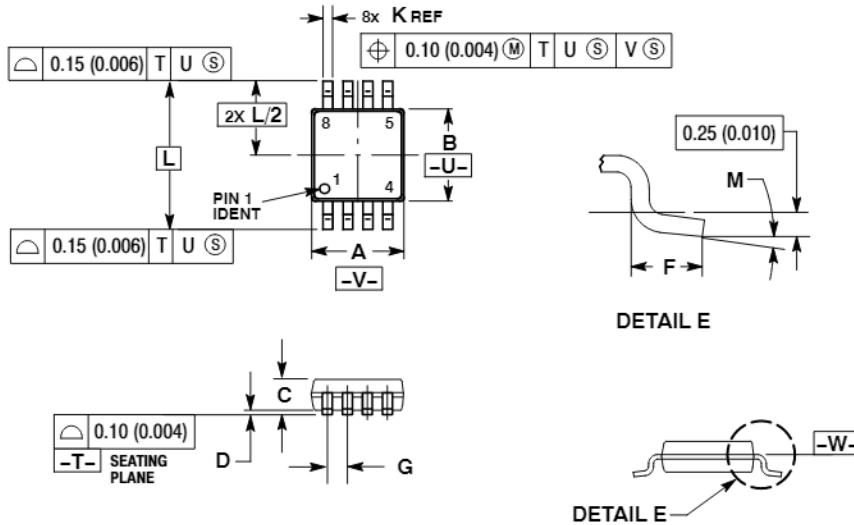

**NOTES:**

1. DIMENSIONING AND TOLERANCING PER ANSI Y14.5M, 1982.
2. CONTROLLING DIMENSION: MILLIMETER.
3. DIMENSION A DOES NOT INCLUDE MOLD FLASH, PROTRUSIONS OR GATE BURRS. MOLD FLASH OR GATE BURRS SHALL NOT EXCEED 0.15 (0.006) PER SIDE.
4. DIMENSION B DOES NOT INCLUDE INTERLEAD FLASH OR PROTRUSION. INTERLEAD FLASH OR PROTRUSION SHALL NOT EXCEED 0.25 (0.010) PER SIDE.
5. TERMINAL NUMBERS ARE SHOWN FOR REFERENCE ONLY.
6. DIMENSION A AND B ARE TO BE DETERMINED AT DATUM PLANE -W-.

DIM	MILLIMETERS		INCHES	
	MIN	MAX	MIN	MAX
A	2.90	3.10	0.114	0.122
B	2.90	3.10	0.114	0.122
C	0.80	1.10	0.031	0.043
D	0.05	0.15	0.002	0.006
F	0.40	0.70	0.016	0.028
G	0.65 BSC		0.026 BSC	
K	0.25	0.40	0.010	0.016
L	4.90 BSC		0.193 BSC	
M	0°	6°	0°	6°

ECLinPS is a trademark of Semiconductor Components Industries, LLC (SCILLC) or its subsidiaries in the United States and/or other countries.

ON Semiconductor and are trademarks of Semiconductor Components Industries, LLC dba ON Semiconductor or its subsidiaries in the United States and/or other countries. ON Semiconductor owns the rights to a number of patents, trademarks, copyrights, trade secrets, and other intellectual property. A listing of ON Semiconductor's product/patent coverage may be accessed at [www.onsemi.com/site/pdf/Patent-Marking.pdf](http://www.onsemi.com/site/pdf/Patent-Marking.pdf). ON Semiconductor reserves the right to make changes without further notice to any products herein. ON Semiconductor makes no warranty, representation or guarantee regarding the suitability of its products for any particular purpose, nor does ON Semiconductor assume any liability arising out of the application or use of any product or circuit, and specifically disclaims any and all liability, including without limitation special, consequential or incidental damages. Buyer is responsible for its products and applications using ON Semiconductor products, including compliance with all laws, regulations and safety requirements or standards, regardless of any support or applications information provided by ON Semiconductor. "Typical" parameters which may be provided in ON Semiconductor data sheets and/or specifications can and do vary in different applications and actual performance may vary over time. All operating parameters, including "Typicals" must be validated for each customer application by customer's technical experts. ON Semiconductor does not convey any license under its patent rights nor the rights of others. ON Semiconductor products are not designed, intended, or authorized for use as a critical component in life support systems or any FDA Class 3 medical devices or medical devices with a same or similar classification in a foreign jurisdiction or any devices intended for implantation in the human body. Should Buyer purchase or use ON Semiconductor products for any such unintended or unauthorized application, Buyer shall indemnify and hold ON Semiconductor and its officers, employees, subsidiaries, affiliates, and distributors harmless against all claims, costs, damages, and expenses, and reasonable attorney fees arising out of, directly or indirectly, any claim of personal injury or death associated with such unintended or unauthorized use, even if such claim alleges that ON Semiconductor was negligent regarding the design or manufacture of the part. ON Semiconductor is an Equal Opportunity/Affirmative Action Employer. This literature is subject to all applicable copyright laws and is not for resale in any manner.

### PUBLICATION ORDERING INFORMATION

**LITERATURE FULFILLMENT**

Literature Distribution Center for ON Semiconductor  
19521 E. 32nd Pkwy, Aurora, Colorado 80011 USA  
Phone: 303-675-2175 or 800-344-3860 Toll Free USA/Canada  
Fax: 303-675-2176 or 800-344-3867 Toll Free USA/Canada  
Email: [orderlit@onsemi.com](mailto:orderlit@onsemi.com)

**N. American Technical Support:** 800-282-9855 Toll Free USA/Canada  
**Europe, Middle East and Africa Technical Support:** Phone: 421 33 790 2910  
**Japan Customer Focus Center** Phone: 81-3-5817-1050

**ON Semiconductor Website:** [www.onsemi.com](http://www.onsemi.com)  
**Order Literature:** <http://www.onsemi.com/orderlit>

For additional information, please contact your local Sales Representative