

MC74HCT4051A, MC74HCT4052A, MC74HCT4053A

Analog Multiplexers / Demultiplexers with LSTTL Compatible Inputs

High-Performance Silicon-Gate CMOS

The MC74HCT4051A, MC74HCT4052A and MC74HCT4053A utilize silicon-gate CMOS technology to achieve fast propagation delays, low ON resistances, and low OFF leakage currents. These analog multiplexers/demultiplexers control analog voltages that may vary across the complete power supply range (from V_{CC} to V_{EE}).

The HCT4051A, HCT4052A and HCT4053A are identical in pinout to the metal-gate MC14051AB, MC14052AB and MC14053AB. The Channel-Select inputs determine which one of the Analog Inputs/Outputs is to be connected, by means of an analog switch, to the Common Output/Input. When the Enable pin is HIGH, all analog switches are turned off.

The Channel-Select and Enable inputs are compatible with standard CMOS and LSTTL outputs.

These devices have been designed so that the ON resistance (R_{on}) is more linear over input voltage than R_{on} of metal-gate CMOS analog switches.

For a multiplexer/demultiplexer with injection current protection, see HC4851A and HCT4851A.

Features

- Fast Switching and Propagation Speeds
- Low Crosstalk Between Switches
- Diode Protection on All Inputs/Outputs
- Analog Power Supply Range ($V_{CC} - V_{EE}$) = 2.0 to 12.0 V
- Digital (Control) Power Supply Range ($V_{CC} - GND$) = 2.0 to 6.0 V
- Improved Linearity and Lower ON Resistance Than Metal-Gate Counterparts
- Low Noise
- In Compliance with the Requirements of JEDEC Standard No. 7 A
- Chip Complexity: HCT4051A – 184 FETs or 46 Equivalent Gates
HCT4052A – 168 FETs or 42 Equivalent Gates
HCT4053A – 156 FETs or 39 Equivalent Gates
- These Devices are Pb-Free and are RoHS Compliant



ON Semiconductor®

<http://onsemi.com>

MARKING DIAGRAMS

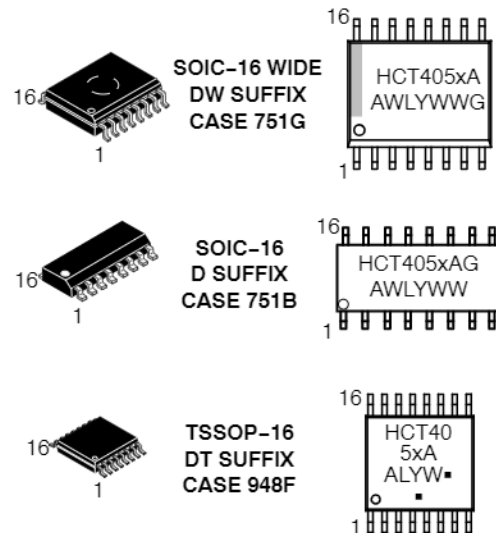

x = 1, 2, 3
A = Assembly Location
WL, L = Wafer Lot
YY, Y = Year
WW, W = Work Week
G or ▪ = Pb-Free Package

(Note: Microdot may be in either location)

ORDERING INFORMATION

See detailed ordering and shipping information in the package dimensions section on page 13 of this data sheet.

MC74HCT4051A, MC74HCT4052A, MC74HCT4053A

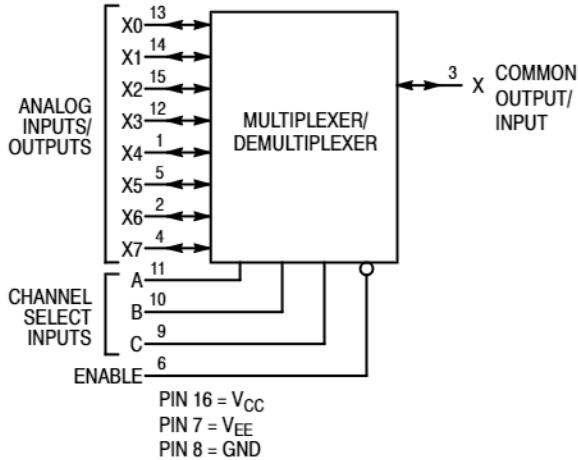

Figure 1. Logic Diagram - MC74HCT4051A
Single-Pole, 8-Position Plus Common Off

FUNCTION TABLE - MC74HCT4051A

Control Inputs		ON Channels		
Enable	Select			
	C	B	A	
L	L	L	L	X0
L	L	L	H	X1
L	L	H	L	X2
L	L	H	H	X3
L	H	L	L	X4
L	H	L	H	X5
L	H	H	L	X6
L	H	H	H	X7
H	X	X	X	NONE

X = Don't Care

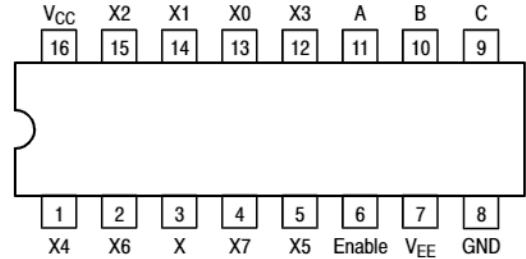

Figure 2. Pinout: MC74HCT4051A

(Top View)

FUNCTION TABLE - MC74HCT4052A

Control Inputs		ON Channels	
Enable	Select		
	B	A	
L	L	L	Y0 X0
L	L	H	Y1 X1
L	H	L	Y2 X2
L	H	H	Y3 X3
H	X	X	NONE

X = Don't Care

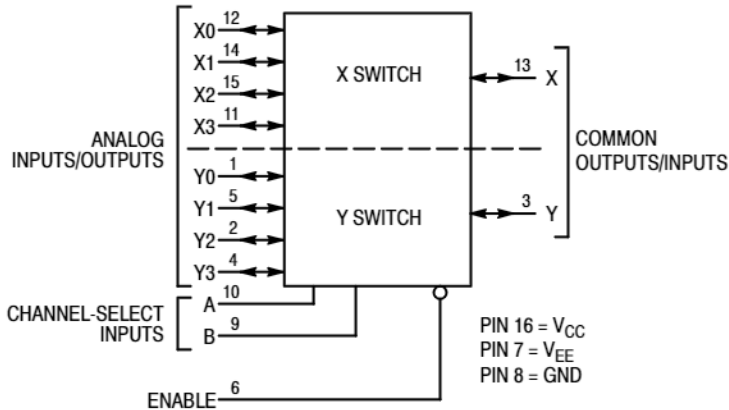

Figure 3. Logic Diagram - MC74HCT4052A
Double-Pole, 4-Position Plus Common Off

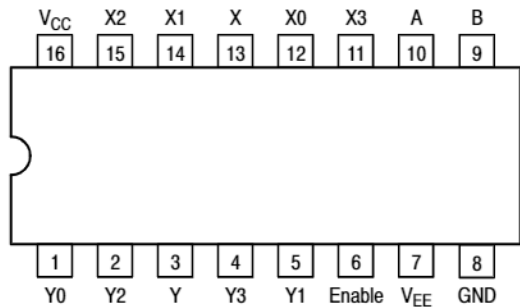
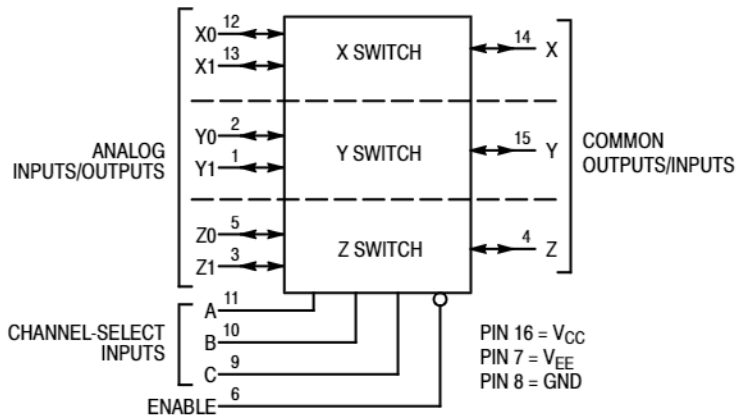

Figure 4. Pinout: MC74HCT4052A (Top View)

MC74HCT4051A, MC74HCT4052A, MC74HCT4053A



NOTE: This device allows independent control of each switch. Channel-Select Input A controls the X-Switch, Input B controls the Y-Switch and Input C controls the Z-Switch

Figure 5. Logic Diagram - MC74HCT4053A Triple Single-Pole, Double-Position Plus Common Off

FUNCTION TABLE - MC74HCT4053A

Control Inputs		ON Channels		
Enable	Select			
	C	B	A	
L	L	L	L	Z0 Y0 X0
L	L	L	H	Z0 Y0 X1
L	L	H	L	Z0 Y1 X0
L	L	H	H	Z0 Y1 X1
L	H	L	L	Z1 Y0 X0
L	H	L	H	Z1 Y0 X1
L	H	H	L	Z1 Y1 X0
L	H	H	H	Z1 Y1 X1
H	X	X	X	NONE

X = Don't Care

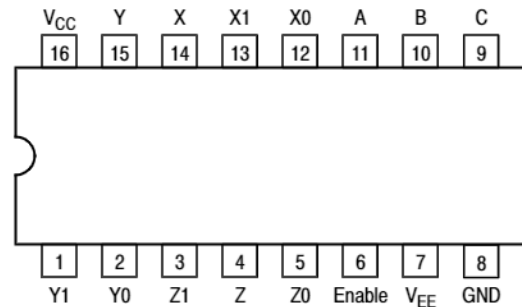

Figure 6. Pinout: MC74HCT4053A (Top View)

MAXIMUM RATINGS

Symbol	Parameter	Value	Unit
V _{CC}	Positive DC Supply Voltage (Referenced to GND) (Referenced to V _{EE})	-0.5 to +7.0 -0.5 to +14.0	V
V _{EE}	Negative DC Supply Voltage (Referenced to GND)	-7.0 to +5.0	V
V _{IS}	Analog Input Voltage	V _{EE} - 0.5 to V _{CC} + 0.5	V
V _{in}	Digital Input Voltage (Referenced to GND)	-0.5 to V _{CC} + 0.5	V
I	DC Current, Into or Out of Any Pin	±25	mA
P _D	Power Dissipation in Still Air, SOIC Package† TSSOP Package†	500 450	mW
T _{stg}	Storage Temperature Range	-65 to +150	°C

This device contains protection circuitry to guard against damage due to high static voltages or electric fields. However, precautions must be taken to avoid applications of any voltage higher than maximum rated voltages to this high-impedance circuit. For proper operation, V_{in} and V_{out} should be constrained to the range GND ≤ (V_{in} or V_{out}) ≤ V_{CC}. Unused inputs must always be tied to an appropriate logic voltage level (e.g., either GND or V_{CC}). Unused outputs must be left open.

Stresses exceeding Maximum Ratings may damage the device. Maximum Ratings are stress ratings only. Functional operation above the Recommended Operating Conditions is not implied. Extended exposure to stresses above the Recommended Operating Conditions may affect device reliability.

†Derating - SOIC Package: - 7 mW/°C from 65°C to 125°C
TSSOP Package: - 6.1 mW/°C from 65°C to 125°C

MC74HCT4051A, MC74HCT4052A, MC74HCT4053A

RECOMMENDED OPERATING CONDITIONS

Symbol	Parameter	Min	Max	Unit	
V _{CC}	Positive DC Supply Voltage (Referenced to GND) (Referenced to V _{EE})	2.0 2.0	6.0 12.0	V	
V _{EE}	Negative DC Supply Voltage, Output (Referenced to GND)	-6.0	GND	V	
V _{IS}	Analog Input Voltage	V _{EE}	V _{CC}	V	
V _{in}	Digital Input Voltage (Referenced to GND)	GND	V _{CC}	V	
V _{IO*}	Static or Dynamic Voltage Across Switch		1.2	V	
T _A	Operating Temperature Range, All Package Types	-55	+125	°C	
t _r , t _f	Input Rise/Fall Time (Channel Select or Enable Inputs)	V _{CC} = 2.0 V V _{CC} = 3.0 V V _{CC} = 4.5 V V _{CC} = 6.0 V	0 0 0 0	1000 600 500 400	ns

*For voltage drops across switch greater than 1.2 V (switch on), excessive V_{CC} current may be drawn; i.e., the current out of the switch may contain both V_{CC} and switch input components. The reliability of the device will be unaffected unless the Maximum Ratings are exceeded.

DC CHARACTERISTICS – Digital Section (Voltages Referenced to GND) V_{EE} = GND, Except Where Noted

Symbol	Parameter	Condition	V _{CC} V	Guaranteed Limit			Unit	
				-55 to 25°C	≤85°C	≤125°C		
V _{IH}	Minimum High-Level Input Voltage, Channel-Select or Enable Inputs	R _{on} = Per Spec	4.5 to 5.5	2.0	2.0	2.0	V	
V _{IL}	Maximum Low-Level Input Voltage, Channel-Select or Enable Inputs	R _{on} = Per Spec	4.5 to 5.5	0.8	0.8	0.8	V	
I _{in}	Maximum Input Leakage Current, Channel-Select or Enable Inputs	V _{in} = V _{CC} or GND, V _{EE} = -6.0 V	6.0	±0.1	±1.0	±1.0	μA	
I _{CC}	Maximum Quiescent Supply Current (per Package)	Channel Select, Enable and V _{IS} = V _{CC} or GND; V _{IO} = 0 V	V _{EE} = GND V _{EE} = -6.0	6.0 6.0	1 4	10 40	20 80	μA

DC CHARACTERISTICS – Analog Section

Symbol	Parameter	Condition	V _{CC}	V _{EE}	Guaranteed Limit			Unit	
					-55 to 25°C	≤85°C	≤125°C		
R _{on}	Maximum "ON" Resistance	V _{in} = V _{IL} or V _{IH} ; V _{IS} = V _{CC} to V _{EE} ; I _S ≤ 2.0 mA (Figures 7, 8)	4.5	0.0	190	240	280	Ω	
			4.5	-4.5	120	150	170		
		6.0	-6.0	100	125	140			
		4.5	0.0	150	190	230			
4.5	-4.5						100	125	140
ΔR _{on}	Maximum Difference in "ON" Resistance Between Any Two Channels in the Same Package	V _{in} = V _{IL} or V _{IH} ; V _{IS} = 1/2 (V _{CC} - V _{EE}); I _S ≤ 2.0 mA	4.5	0.0	30	35	40	Ω	
			4.5	-4.5	12	15	18		
			6.0	-6.0	10	12	14		
I _{off}	Maximum Off-Channel Leakage Current, Any One Channel	V _{in} = V _{IL} or V _{IH} ; V _{IO} = V _{CC} - V _{EE} ; Switch Off (Figure 9)	5.0	-5.0	0.1	0.5	1.0	μA	
			5.0	-5.0	0.1	0.5	1.0		
	Maximum Off-Channel Leakage Current, Common Channel	HCT4051A HCT4052A HCT4053A	V _{in} = V _{IL} or V _{IH} ; V _{IO} = V _{CC} - V _{EE} ; Switch Off (Figure 10)	5.0	-5.0	0.2	2.0		4.0
				5.0	-5.0	0.1	1.0		2.0
I _{on}	Maximum On-Channel Leakage Current, Channel-to-Channel	HCT4051A HCT4052A HCT4053A	V _{in} = V _{IL} or V _{IH} ; Switch-to-Switch = V _{CC} - V _{EE} ; (Figure 11)	5.0	-5.0	0.2	2.0	4.0	μA
				5.0	-5.0	0.1	1.0	2.0	
				5.0	-5.0	0.1	1.0	2.0	

MC74HCT4051A, MC74HCT4052A, MC74HCT4053A

AC CHARACTERISTICS ($C_L = 50$ pF, Input $t_r = t_f = 6$ ns)

Symbol	Parameter	V _{CC} V	Guaranteed Limit			Unit
			-55 to 25°C	≤85°C	≤125°C	
t _{PLH} , t _{PHL}	Maximum Propagation Delay, Channel-Select to Analog Output (Figure 15)	2.0	270	320	350	ns
		3.0	90	110	125	
		4.5	59	79	85	
		6.0	45	65	75	
t _{PLH} , t _{PHL}	Maximum Propagation Delay, Analog Input to Analog Output (Figure 16)	2.0	40	60	70	ns
		3.0	25	30	32	
		4.5	12	15	18	
		6.0	10	13	15	
t _{PLZ} , t _{PHZ}	Maximum Propagation Delay, Enable to Analog Output (Figure 17)	2.0	160	200	220	ns
		3.0	70	95	110	
		4.5	48	63	76	
		6.0	39	55	63	
t _{PZL} , t _{PZH}	Maximum Propagation Delay, Enable to Analog Output (Figure 17)	2.0	245	315	345	ns
		3.0	115	145	155	
		4.5	49	69	83	
		6.0	39	58	67	
C _{in}	Maximum Input Capacitance, Channel-Select or Enable Inputs		10	10	10	pF
C _{I/O}	Maximum Capacitance (All Switches Off)	Analog I/O	35	35	35	pF
		Common O/I: HCT4051A	130	130	130	
		HCT4052A	80	80	80	
		HCT4053A	50	50	50	
	Feed-through		1.0	1.0	1.0	

Symbol	Parameter	Device	Typical @ 25°C, V _{CC} = 5.0 V, V _{EE} = 0 V	Unit
			C _{PD}	

*Used to determine the no-load dynamic power consumption: $P_D = C_{PD} V_{CC}^2 f + I_{CC} V_{CC}$.

MC74HCT4051A, MC74HCT4052A, MC74HCT4053A

ADDITIONAL APPLICATION CHARACTERISTICS (GND = 0 V)

Symbol	Parameter	Condition	V _{CC} V	V _{EE} V	Limit*			Unit
					25°C			
BW	Maximum On-Channel Bandwidth or Minimum Frequency Response (Figure 12)	f _{in} = 1 MHz Sine Wave; Adjust f _{in} Voltage to Obtain 0 dBm at V _{OS} ; Increase f _{in} Frequency Until dB Meter Reads -3 dB; R _L = 50 Ω, C _L = 10 pF	2.25	-2.25	'51	'52	'53	MHz
			4.50	-4.50	80	95	120	
			6.00	-6.00	80	95	120	
-	Off-Channel Feed-through Isolation (Figure 13)	f _{in} = Sine Wave; Adjust f _{in} Voltage to Obtain 0 dBm at V _{IS} f _{in} = 10 kHz, R _L = 600 Ω, C _L = 50 pF	2.25	-2.25	-50			dB
			4.50	-4.50	-50			
			6.00	-6.00	-50			
-	Feedthrough Noise. Channel-Select Input to Common I/O (Figure 14)	V _{in} ≤ 1 MHz Square Wave (t _r = t _f = 6 ns); Adjust R _L at Setup so that I _S = 0 A; Enable = GND R _L = 600 Ω, C _L = 50 pF	2.25	-2.25	25			mV _{PP}
			4.50	-4.50	105			
			6.00	-6.00	135			
-	Crosstalk Between Any Two Switches (Figure 18) (Test does not apply to HCT4051A)	f _{in} = Sine Wave; Adjust f _{in} Voltage to Obtain 0 dBm at V _{IS} f _{in} = 10 kHz, R _L = 600 Ω, C _L = 50 pF	2.25	-2.25	-50			dB
			4.50	-4.50	-50			
			6.00	-6.00	-50			
-	Crosstalk Between Any Two Switches (Figure 18) (Test does not apply to HCT4051A)	f _{in} = 1.0 MHz, R _L = 50 Ω, C _L = 10 pF	2.25	-2.25	-40			dB
			4.50	-4.50	-40			
			6.00	-6.00	-40			
THD	Total Harmonic Distortion (Figure 20)	f _{in} = 1 kHz, R _L = 10 kΩ, C _L = 50 pF THD = THD _{measured} - THD _{source} V _{IS} = 4.0 V _{PP} sine wave V _{IS} = 8.0 V _{PP} sine wave V _{IS} = 11.0 V _{PP} sine wave	2.25	-2.25	0.10			%
			4.50	-4.50	0.08			
			6.00	-6.00	0.05			

*Limits not tested. Determined by design and verified by qualification.

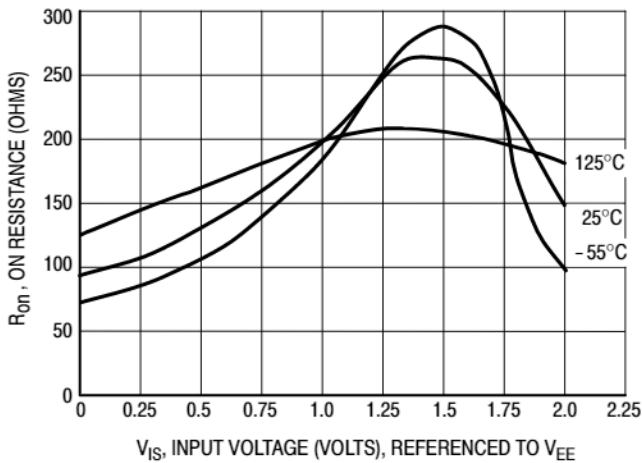

Figure 7a. Typical On Resistance, V_{CC} - V_{EE} = 2.0 V

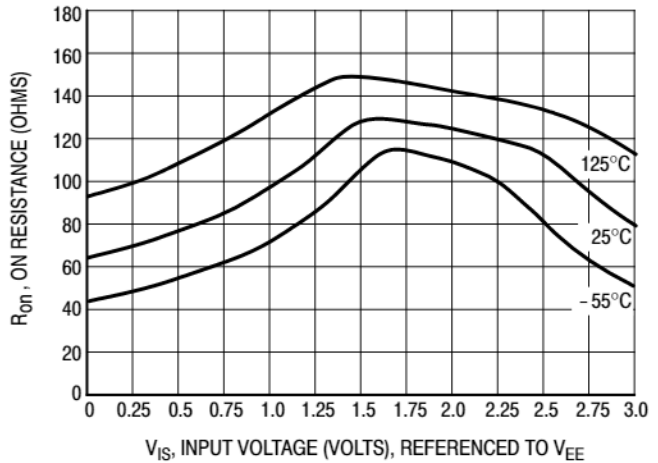

Figure 7b. Typical On Resistance, V_{CC} - V_{EE} = 3.0 V

MC74HCT4051A, MC74HCT4052A, MC74HCT4053A

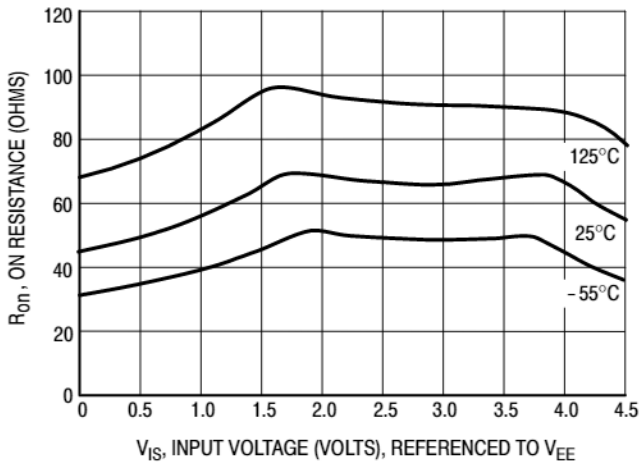

Figure 7c. Typical On Resistance, $V_{CC} - V_{EE} = 4.5\text{ V}$

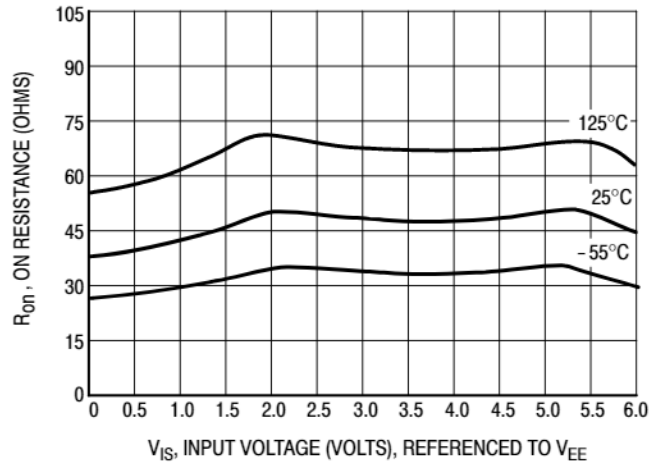

Figure 7d. Typical On Resistance, $V_{CC} - V_{EE} = 6.0\text{ V}$

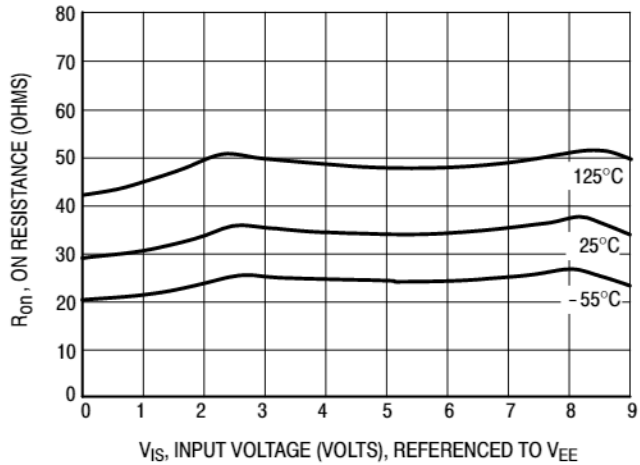

Figure 7e. Typical On Resistance, $V_{CC} - V_{EE} = 9.0\text{ V}$

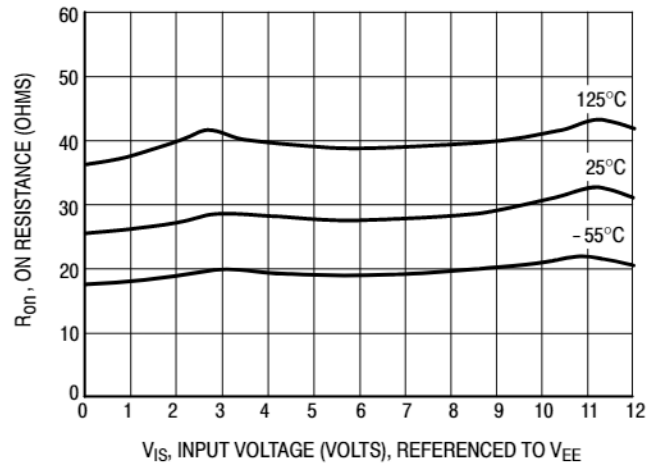

Figure 7f. Typical On Resistance, $V_{CC} - V_{EE} = 12.0\text{ V}$

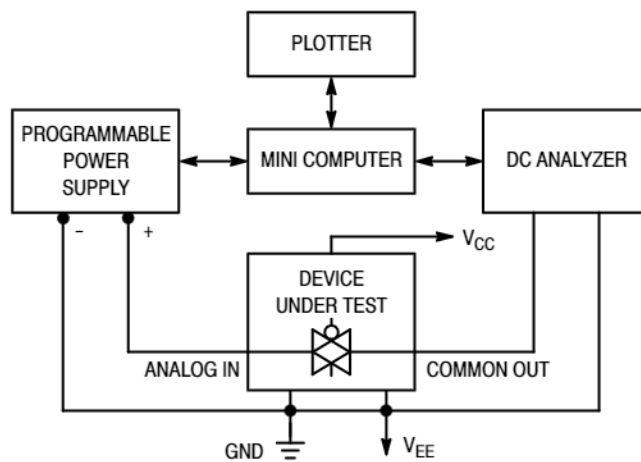

Figure 8. On Resistance Test Set-Up

MC74HCT4051A, MC74HCT4052A, MC74HCT4053A

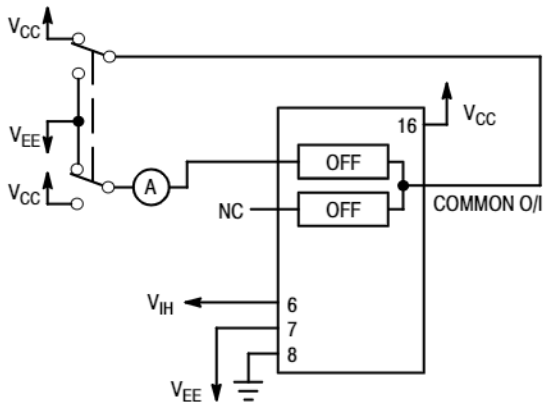

Figure 9. Maximum Off Channel Leakage Current, Any One Channel, Test Set-Up

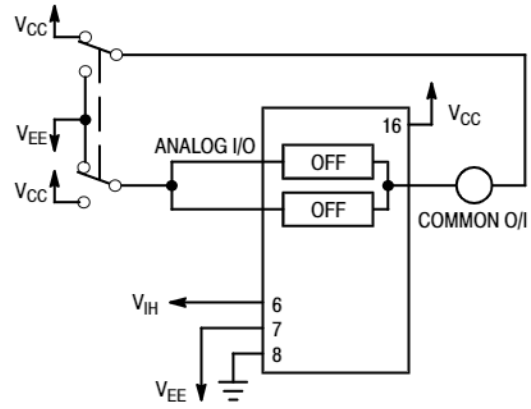

Figure 10. Maximum Off Channel Leakage Current, Common Channel, Test Set-Up

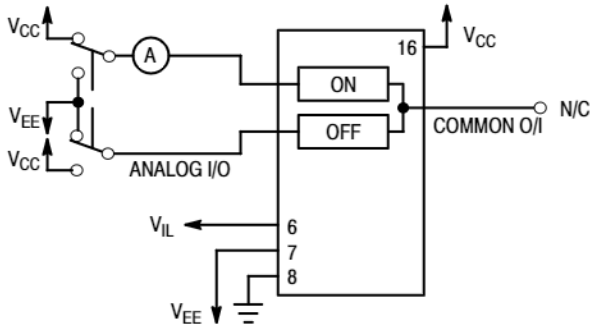
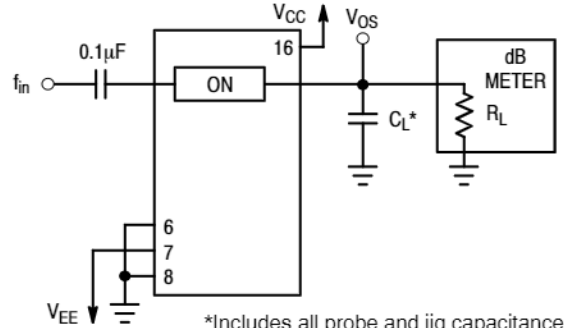
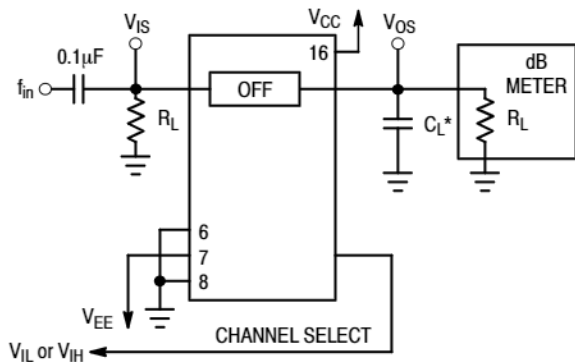

Figure 11. Maximum On Channel Leakage Current, Channel to Channel, Test Set-Up



*Includes all probe and jig capacitance

Figure 12. Maximum On Channel Bandwidth, Test Set-Up



*Includes all probe and jig capacitance

Figure 13. Off Channel Feedthrough Isolation, Test Set-Up

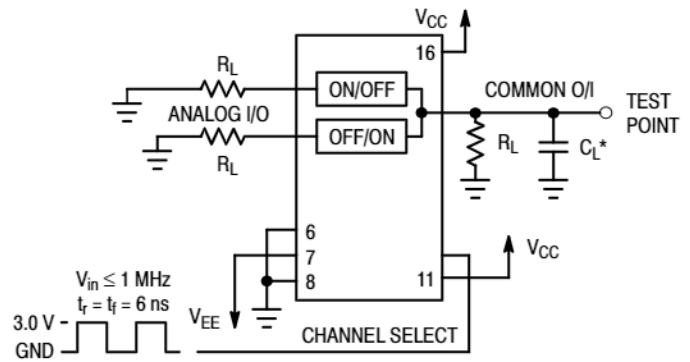

*Includes all probe and jig capacitance

Figure 14. Feedthrough Noise, Channel Select to Common Out, Test Set-Up

MC74HCT4051A, MC74HCT4052A, MC74HCT4053A

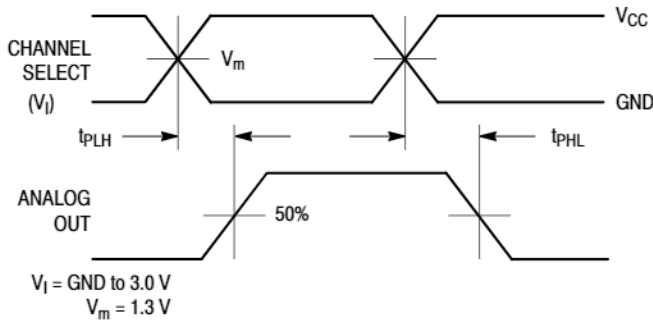
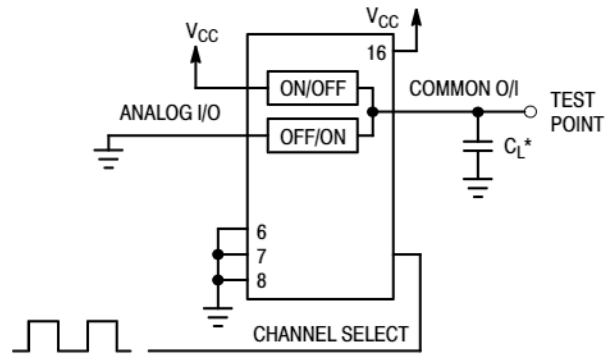

Figure 15a. Propagation Delays, Channel Select to Analog Out



*Includes all probe and jig capacitance

Figure 15b. Propagation Delay, Test Set-Up Channel Select to Analog Out

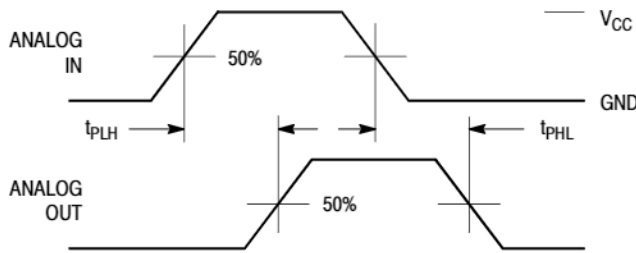
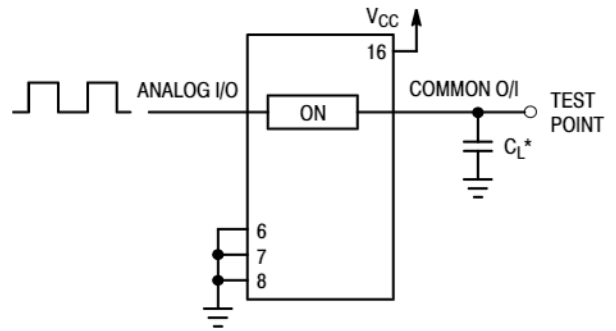

Figure 16a. Propagation Delays, Analog In to Analog Out



*Includes all probe and jig capacitance

Figure 16b. Propagation Delay, Test Set-Up Analog In to Analog Out

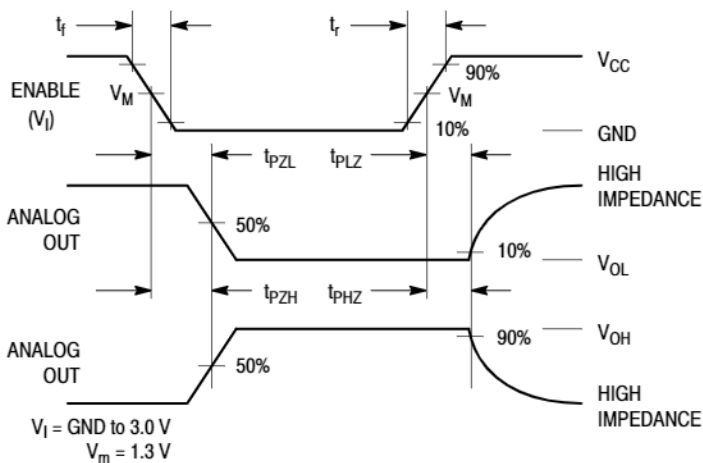

Figure 17a. Propagation Delays, Enable to Analog Out

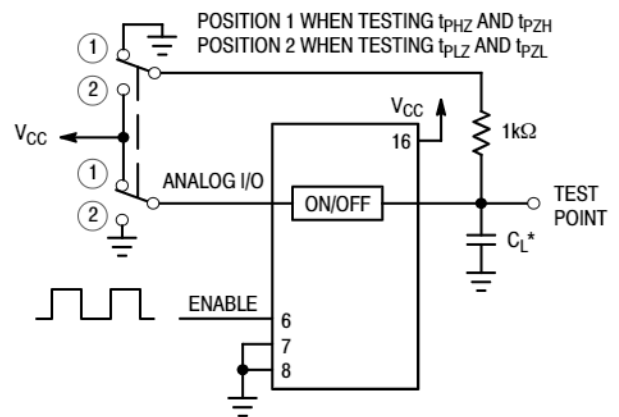
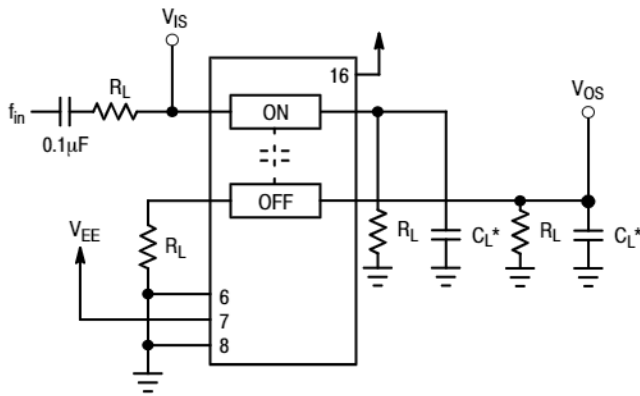

Figure 17b. Propagation Delay, Test Set-Up Enable to Analog Out

MC74HCT4051A, MC74HCT4052A, MC74HCT4053A



*Includes all probe and jig capacitance

Figure 18. Crosstalk Between Any Two Switches, Test Set-Up

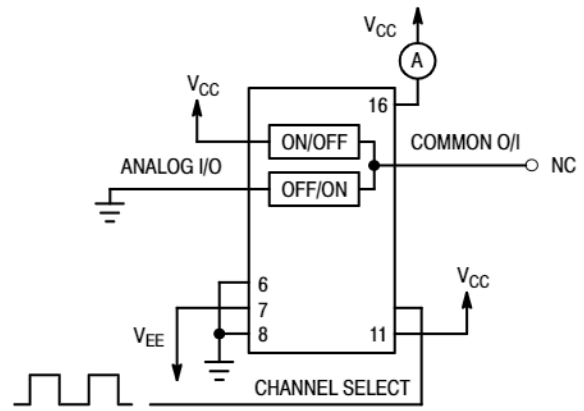
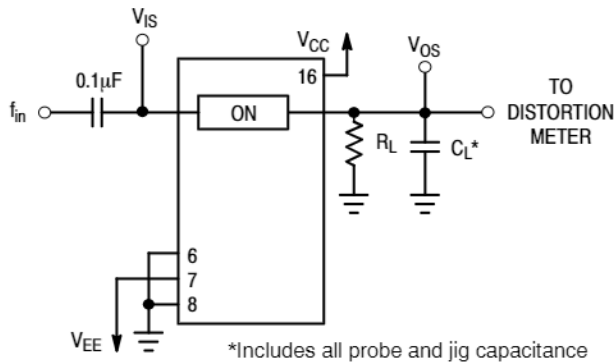

Figure 19. Power Dissipation Capacitance, Test Set-Up



*Includes all probe and jig capacitance

Figure 20a. Total Harmonic Distortion, Test Set-Up

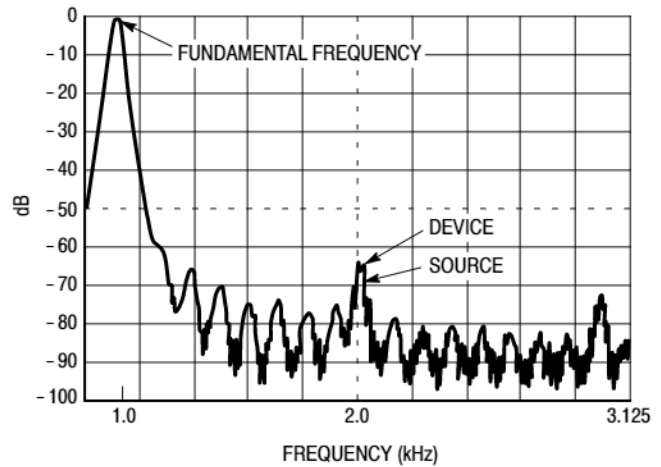

Figure 20b. Plot, Harmonic Distortion

APPLICATIONS INFORMATION

The maximum analog voltage swings are determined by the supply voltages V_{CC} and V_{EE} . The positive peak analog voltage should not exceed V_{CC} . Similarly, the negative peak analog voltage should not go below V_{EE} . In this example, the difference between V_{CC} and V_{EE} is ten volts. Therefore, using the configuration of Figure 21, a maximum analog signal of ten volts peak-to-peak can be controlled. Unused analog inputs/outputs may be left floating (i.e., not connected). However, tying unused analog inputs and outputs to V_{CC} or GND through a low value resistor helps minimize crosstalk and feed-through noise that may be picked up by an unused switch.

Although used here, balanced supplies are not a requirement. The only constraints on the power supplies are that:

$$\begin{aligned} V_{CC} - \text{GND} &= 2 \text{ to } 6 \text{ V} \\ V_{EE} - \text{GND} &= 0 \text{ to } -6 \text{ V} \\ V_{CC} - V_{EE} &= 2 \text{ to } 12 \text{ V} \\ &\text{and } V_{EE} \leq \text{GND} \end{aligned}$$

When voltage transients above V_{CC} and/or below V_{EE} are anticipated on the analog channels, external Germanium or Schottky diodes (D_x) are recommended as shown in Figure 22. These diodes should be able to absorb the maximum anticipated current surges during clipping.

MC74HCT4051A, MC74HCT4052A, MC74HCT4053A

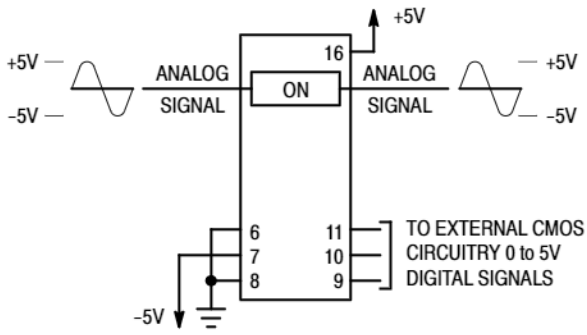

Figure 21. Application Example

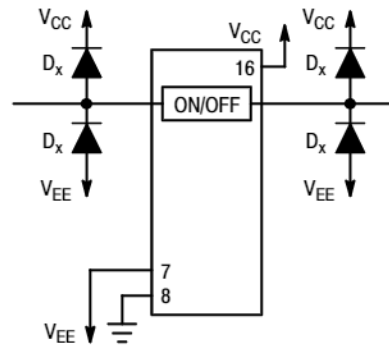
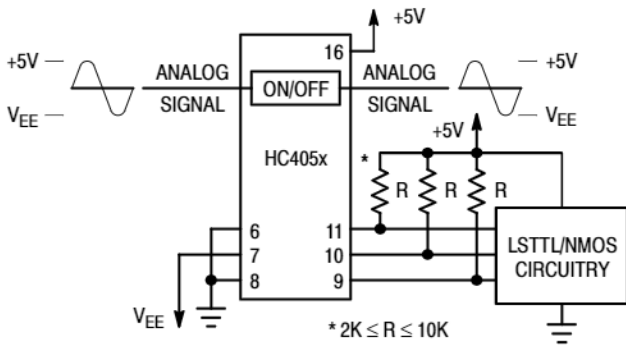
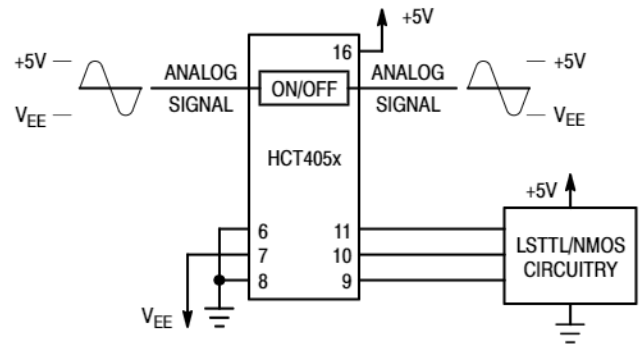

Figure 22. External Germanium or Schottky Clipping Diodes



a. Using Pull-Up Resistors with a HC Device



b. Using HCT Interface

Figure 23. Interfacing LSTTL/NMOS to CMOS Inputs

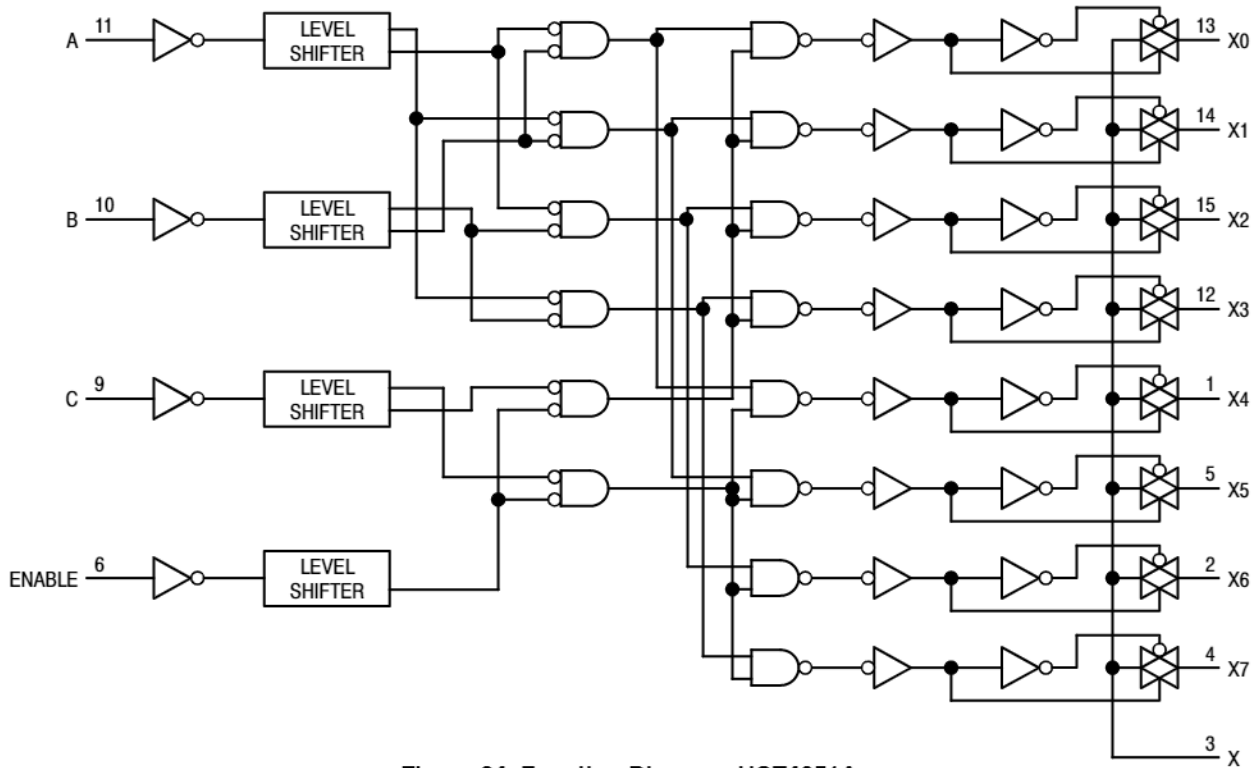

Figure 24. Function Diagram, HCT4051A

MC74HCT4051A, MC74HCT4052A, MC74HCT4053A

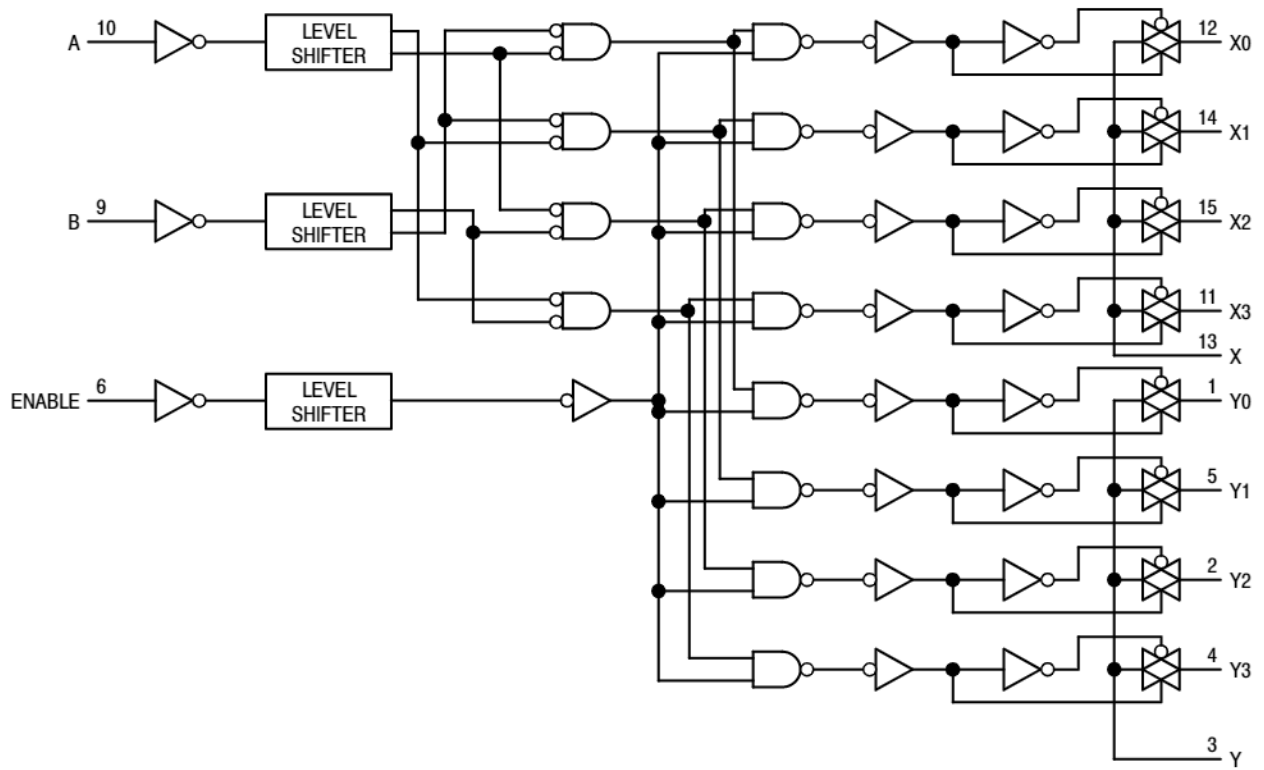

Figure 26. Function Diagram, HCT4052A

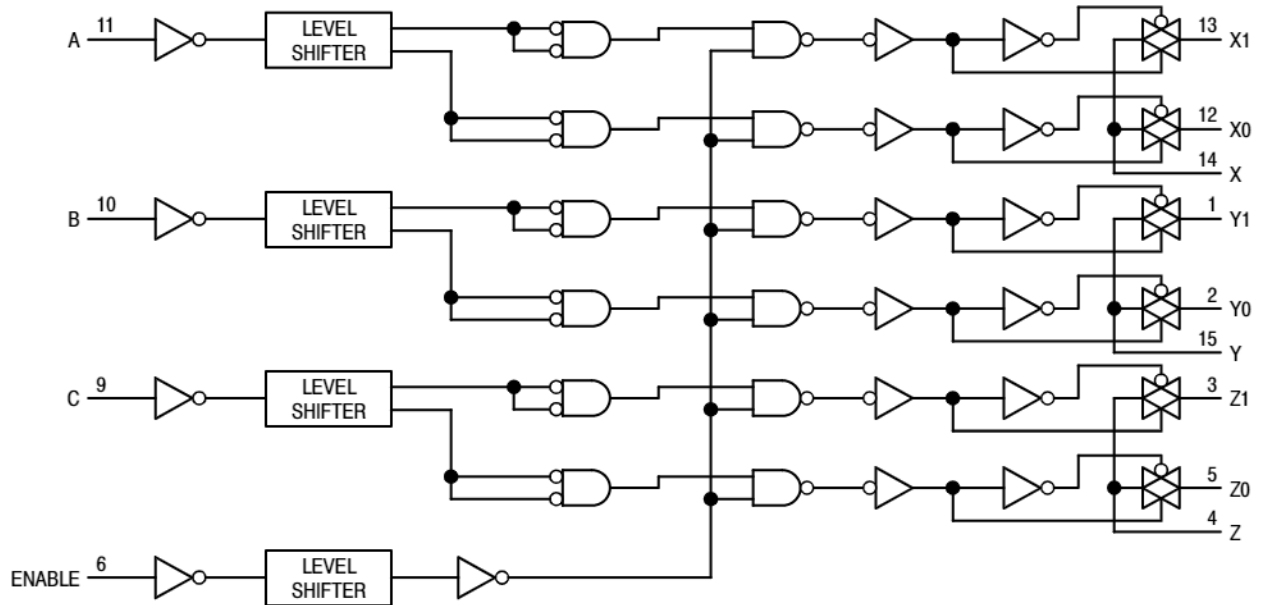

Figure 25. Function Diagram, HCT4053A

MC74HCT4051A, MC74HCT4052A, MC74HCT4053A

ORDERING INFORMATION

Device	Package	Shipping†
MC74HCT4051ADG	SOIC-16 (Pb-Free)	48 Units / Rail
MC74HCT4051ADR2G	SOIC-16 (Pb-Free)	2500 / Tape & Reel
MC74HCT4051ADTG	TSSOP-16*	96 Units / Rail
M74HCT4051ADTR2G	TSSOP-16*	2500 / Tape & Reel
MC74HCT4052ADG	SOIC-16 (Pb-Free)	48 Units / Rail
MC74HCT4052ADR2G	SOIC-16 (Pb-Free)	2500 / Tape & Reel
MC74HCT4052ADTG	TSSOP-16*	96 Units / Rail
M74HCT4052ADTR2G	TSSOP-16*	2500 / Tape & Reel
MC74HCT4052ADWG	SOIC-16 WIDE (Pb-Free)	48 Units / Rail
M74HCT4052ADWR2G	SOIC-16 WIDE (Pb-Free)	1000 / Tape & Reel
MC74HCT4053ADG	SOIC-16 (Pb-Free)	48 Units / Rail
MC74HCT4053ADR2G	SOIC-16 (Pb-Free)	2500 / Tape & Reel
MC74HCT4053ADTG	TSSOP-16*	96 Units / Rail
M74HCT4053ADTR2G	TSSOP-16*	2500 / Tape & Reel

†For information on tape and reel specifications, including part orientation and tape sizes, please refer to our Tape and Reel Packaging Specifications Brochure, BRD8011/D.

*This package is inherently Pb-Free.

MC74HCT4051A, MC74HCT4052A, MC74HCT4053A

PACKAGE DIMENSIONS

TSSOP-16
DT SUFFIX
CASE 948F-01
ISSUE B

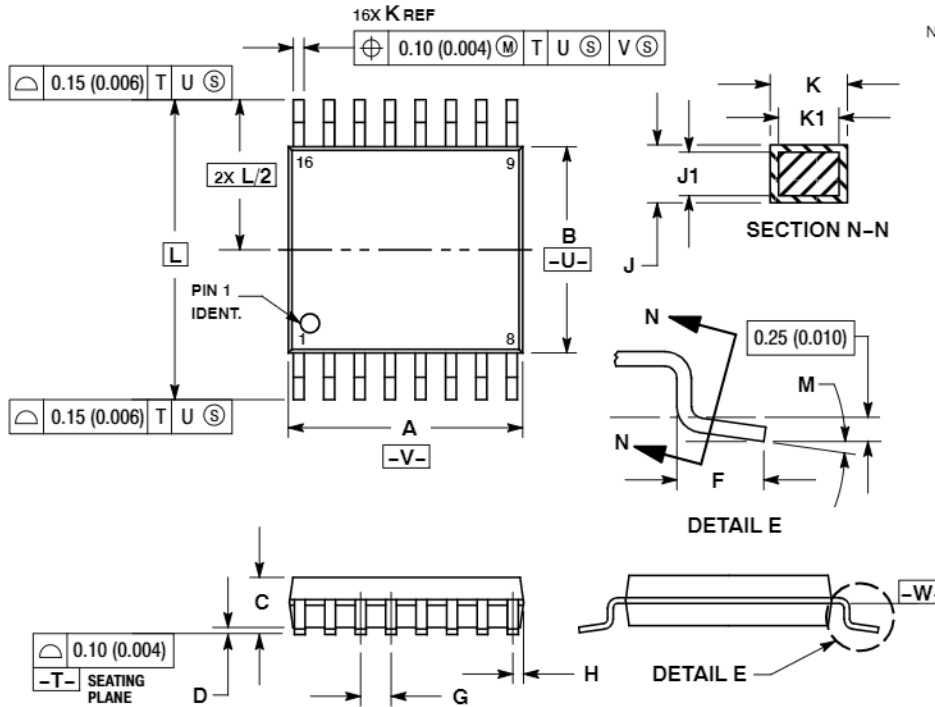

NOTES:

1. DIMENSIONING AND TOLERANCING PER ANSI Y14.5M, 1982.
2. CONTROLLING DIMENSION: MILLIMETER.
3. DIMENSION A DOES NOT INCLUDE MOLD FLASH, PROTRUSIONS OR GATE BURRS. MOLD FLASH OR GATE BURRS SHALL NOT EXCEED 0.15 (0.006) PER SIDE.
4. DIMENSION B DOES NOT INCLUDE INTERLEAD FLASH OR PROTRUSION. INTERLEAD FLASH OR PROTRUSION SHALL NOT EXCEED 0.25 (0.010) PER SIDE.
5. DIMENSION K DOES NOT INCLUDE DAMBAR PROTRUSION. ALLOWABLE DAMBAR PROTRUSION SHALL BE 0.08 (0.003) TOTAL IN EXCESS OF THE K DIMENSION AT MAXIMUM MATERIAL CONDITION.
6. TERMINAL NUMBERS ARE SHOWN FOR REFERENCE ONLY.
7. DIMENSION A AND B ARE TO BE DETERMINED AT DATUM PLANE -W-.

SOLDERING FOOTPRINT*

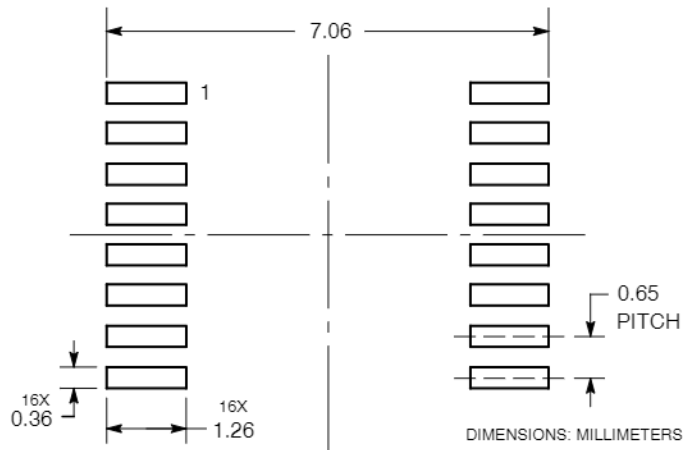

*For additional information on our Pb-Free strategy and soldering details, please download the ON Semiconductor Soldering and Mounting Techniques Reference Manual, SOLDERRM/D.

MC74HCT4051A, MC74HCT4052A, MC74HCT4053A

PACKAGE DIMENSIONS

SOIC-16
D SUFFIX
CASE 751B-05
ISSUE K

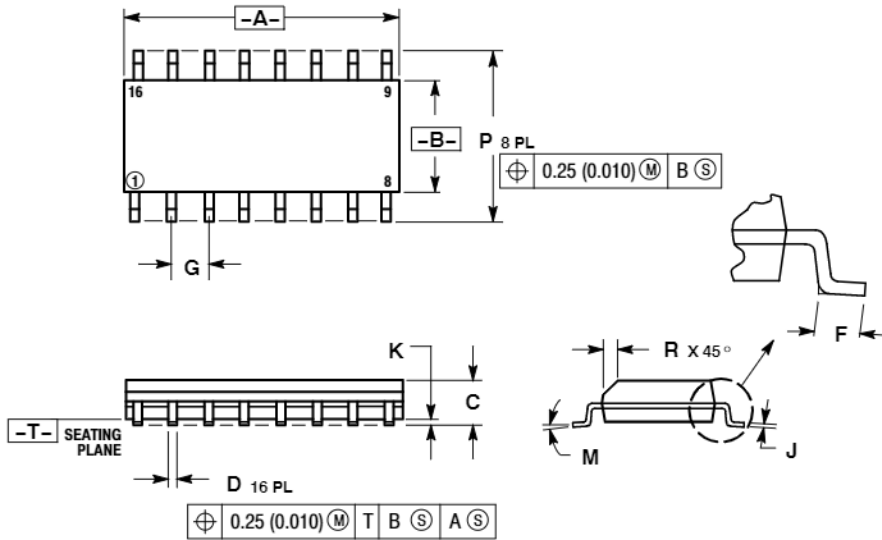

NOTES:

1. DIMENSIONING AND TOLERANCING PER ANSI Y14.5M, 1982.
2. CONTROLLING DIMENSION: MILLIMETER.
3. DIMENSIONS A AND B DO NOT INCLUDE MOLD PROTRUSION.
4. MAXIMUM MOLD PROTRUSION 0.15 (0.006) PER SIDE.
5. DIMENSION D DOES NOT INCLUDE DAMBAR PROTRUSION. ALLOWABLE DAMBAR PROTRUSION SHALL BE 0.127 (0.005) TOTAL IN EXCESS OF THE D DIMENSION AT MAXIMUM MATERIAL CONDITION.

DIM	MILLIMETERS		INCHES	
	MIN	MAX	MIN	MAX
A	9.80	10.00	0.386	0.393
B	3.80	4.00	0.150	0.157
C	1.35	1.75	0.054	0.068
D	0.35	0.49	0.014	0.019
F	0.40	1.25	0.016	0.049
G	1.27 BSC		0.050 BSC	
J	0.19	0.25	0.008	0.009
K	0.10	0.25	0.004	0.009
M	0°	7°	0°	7°
P	5.80	6.20	0.229	0.244
R	0.25	0.50	0.010	0.019

SOLDERING FOOTPRINT*

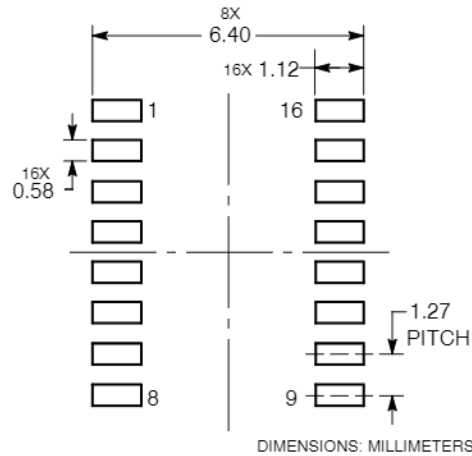

*For additional information on our Pb-Free strategy and soldering details, please download the ON Semiconductor Soldering and Mounting Techniques Reference Manual, SOLDERRM/D.

MC74HCT4051A, MC74HCT4052A, MC74HCT4053A

PACKAGE DIMENSIONS

SOIC-16 WIDE
DW SUFFIX
CASE 751G-03
ISSUE C

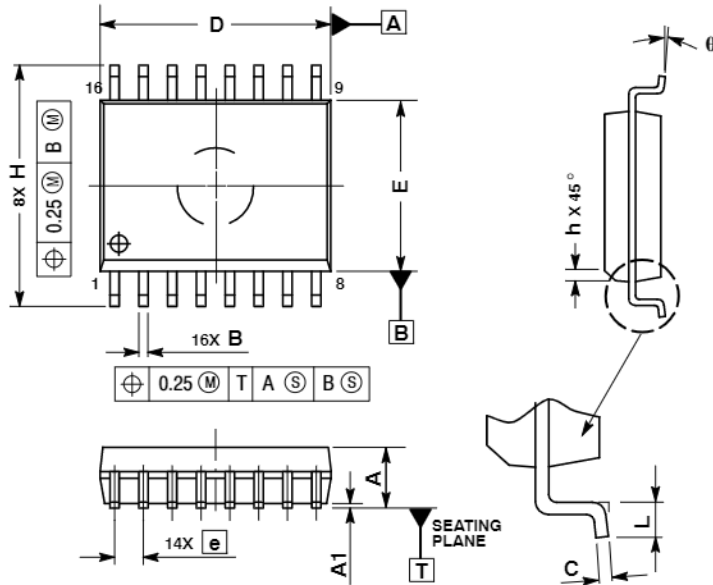

NOTES:

1. DIMENSIONS ARE IN MILLIMETERS.
2. INTERPRET DIMENSIONS AND TOLERANCES PER ASME Y14.5M, 1994.
3. DIMENSIONS D AND E DO NOT INCLUDE MOLD PROTRUSION.
4. MAXIMUM MOLD PROTRUSION 0.15 PER SIDE.
5. DIMENSION B DOES NOT INCLUDE DAMBAR PROTRUSION. ALLOWABLE DAMBAR PROTRUSION SHALL BE 0.13 TOTAL IN EXCESS OF THE B DIMENSION AT MAXIMUM MATERIAL CONDITION.

DIM	MILLIMETERS	
	MIN	MAX
A	2.35	2.65
A1	0.10	0.25
B	0.35	0.49
C	0.23	0.32
D	10.15	10.45
E	7.40	7.60
e	1.27 BSC	
H	10.05	10.55
h	0.25	0.75
L	0.50	0.90
q	0°	7°

ON Semiconductor and **ON** are registered trademarks of Semiconductor Components Industries, LLC (SCILLC). SCILLC reserves the right to make changes without further notice to any products herein. SCILLC makes no warranty, representation or guarantee regarding the suitability of its products for any particular purpose, nor does SCILLC assume any liability arising out of the application or use of any product or circuit, and specifically disclaims any and all liability, including without limitation special, consequential or incidental damages. "Typical" parameters which may be provided in SCILLC data sheets and/or specifications can and do vary in different applications and actual performance may vary over time. All operating parameters, including "Typicals" must be validated for each customer application by customer's technical experts. SCILLC does not convey any license under its patent rights nor the rights of others. SCILLC products are not designed, intended, or authorized for use as components in systems intended for surgical implant into the body, or other applications intended to support or sustain life, or for any other application in which the failure of the SCILLC product could create a situation where personal injury or death may occur. Should Buyer purchase or use SCILLC products for any such unintended or unauthorized application, Buyer shall indemnify and hold SCILLC and its officers, employees, subsidiaries, affiliates, and distributors harmless against all claims, costs, damages, and expenses, and reasonable attorney fees arising out of, directly or indirectly, any claim of personal injury or death associated with such unintended or unauthorized use, even if such claim alleges that SCILLC was negligent regarding the design or manufacture of the part. SCILLC is an Equal Opportunity/Affirmative Action Employer. This literature is subject to all applicable copyright laws and is not for resale in any manner.

PUBLICATION ORDERING INFORMATION

LITERATURE FULFILLMENT

Literature Distribution Center for ON Semiconductor
P.O. Box 5163, Denver, Colorado 80217 USA
Phone: 303-675-2175 or 800-344-3860 Toll Free USA/Canada
Fax: 303-675-2176 or 800-344-3867 Toll Free USA/Canada
Email: orderlit@onsemi.com

N. American Technical Support: 800-282-9855 Toll Free
USA/Canada
Europe, Middle East and Africa Technical Support:
Phone: 421 33 790 2910
Japan Customer Focus Center
Phone: 81-3-5773-3850

ON Semiconductor Website: www.onsemi.com

Order Literature: <http://www.onsemi.com/orderlit>

For additional information, please contact your local Sales Representative