

# Linear LED Driver, 24-Channel, Bus Controlled

## LV52511MNZ

### Overview

The LV52511MN is a serial bus controlled linear low side driver for LEDs (or other loads). The 24 channels are grouped in 3 color blocks (RGB) of 8 channels each. The ON-time for each channel can be programmed by an 8bit register. The reference current is programmed by a single resistor, a 5bit register defines the current for each color block as a fraction (3 to 100%) of the reference current to adjust for color temperature.

Systems parameters can be programmed via 2 wire serial bus, or 3 wire SPI bus with EN, and I<sup>2</sup>C serial bus format (Hs-mode).

### Features

- LED Supply from 3 V to 41 V with Transient Tolerance up to 42 V
- System Supply from 3 V to 20 V with Transient Tolerance up to 24 V
- Up to 60 mA Resistor Defined Maximum Current for All Channels
- 5 bit Individually Adjustable Current for each Color Group RGB
- 8 bit Luminance Dimming for each Channel
- 2 or 3 Wire Bus Interface with up to 56 Slave Addresses
- Thermal and Undervoltage Lock-out Protection
- Thermally Efficient Exposed Die 48 pin QFN Package for Operation up to 85°C Ambient
- These Devices are Pb-Free, Halogen Free/BFR Free and are RoHS Compliant

### Typical Applications

- Gaming (Slot Machine) and Entertainment Equipment
- LED Displays
- Digital Information Signs



ON Semiconductor®

[www.onsemi.com](http://www.onsemi.com)

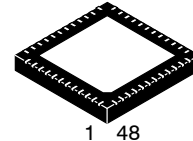

QFN48 7x7  
CASE 485EB

### MARKING DIAGRAM

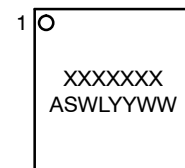

XXX = Specific Device Code  
AS = Assembly Location Code  
WL = Wafer Lot Code  
YY = Year  
WW = Work Week

### ORDERING INFORMATION

Device	Package	Shipping†
LV52511MNZTXG	QFN48 (Pb-Free/ Halogen Free)	2,500 / Tape & Reel

†For information on tape and reel specifications, including part orientation and tape sizes, please refer to our Tape and Reel Packaging Specification Brochure, BRD8011/D.

# LV52511MNZ

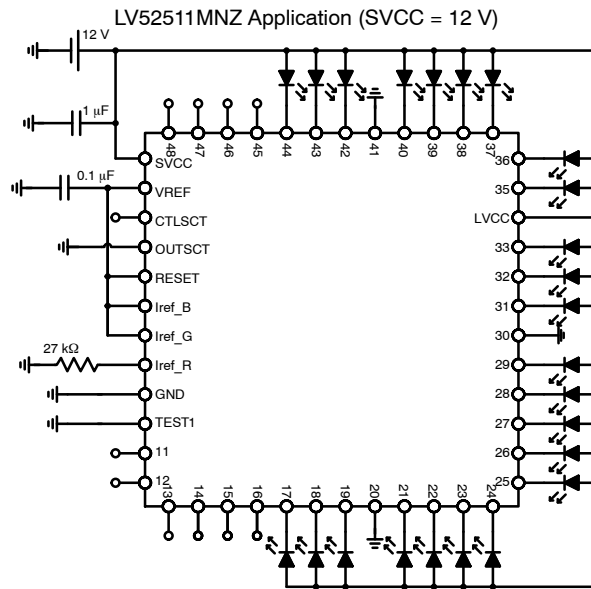

Figure 1. Typical Application Diagram

## PINOUT

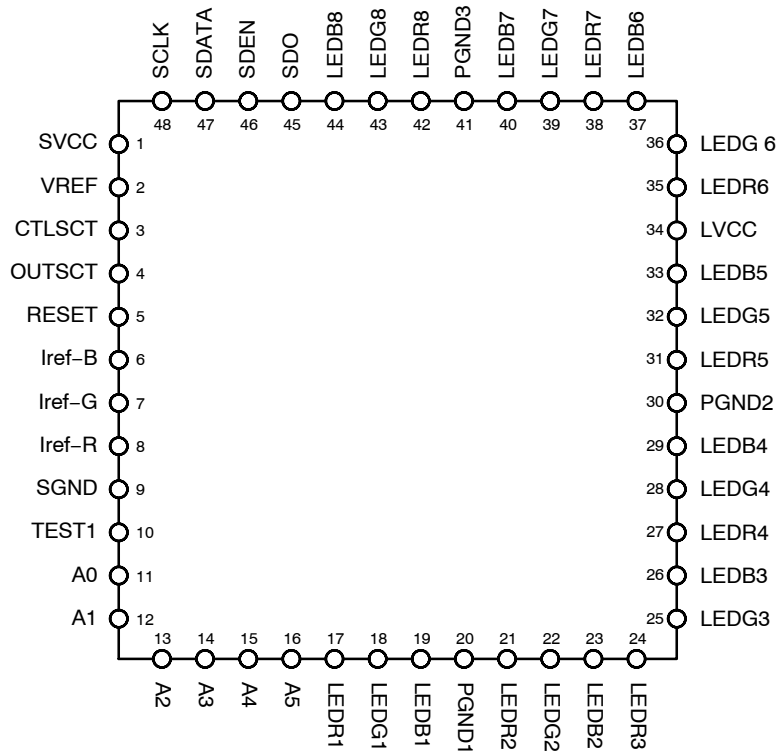

Figure 2. Pin Assignment

# LV52511MNZ

## PIN DESCRIPTIONS

Pin No.	Pin Name	I/O	Description	Pin Circuit
1	SVCC	-	System power supply input. For LED supply voltages from 3 to 20 V connect directly to LED supply. For higher LED voltages SVCC must be limited to 24 V (max)	
2	VREF	O	Internal supply output pin. Regulates to 5 V if SVCC is higher than 5 V. Bypass with a 0.1 $\mu$ F capacitor	
3	CTLSCT	I	Select pin for 2-wire or 3-wire interface and I <sup>2</sup> C. Tie to GND for 3-wire, tie to VREF for 2wire bus, open for I <sup>2</sup> C bus	TYPE 1
4	OUTSCT	I	Analog three level selection pin to set current characteristics for the output channels. See "OUTSCT Setting" on page 10 for details	TYPE 1
5	RESET	I	Active high reset input pin. Clears all register settings. Power on reset connect with VREF.	TYPE 2
6	Iref_B	O	Maximum reference current programming pin. Connect a resistor > 10 k $\Omega$ from this pin to GND to define maximum LED current according to the following formula: $IREF = 1.2 \times 580 / RT$	TYPE 3
7	Iref_G	O	Maximum reference current programming pin. Connect a resistor > 10 k $\Omega$ from this pin to GND to define maximum LED current according to the following formula: $IREF = 1.2 \times 580 / RT$	TYPE 3
8	Iref_R	O	Maximum reference current programming pin. Connect a resistor > 10 k $\Omega$ from this pin to GND to define maximum LED current according to the following formula: $IREF = 1.2 \times 580 / RT$	TYPE 3
9	SGND	-	Analog circuit GND pin	
10	TEST1	I	Test1 pin (connected to GND)	TYPE 4
11-16	A0-A5	I	Slave address setting pin. Refer to "Slave Address Setting" on page 11 for details	TYPE 5
17	LEDR1	O	LED red 1 current output pin	TYPE 6
18	LEDG1	O	LED green 1 current output pin	TYPE 6
19	LEDB1	O	LED blue 1 current output pin	TYPE 6
20	PGND1	-	GND pin dedicated for LED driver. Connect directly to ground plane	
21	LEDR2	O	LED red 2 current output pin	TYPE 6
22	LEDG2	O	LED green 2 current output pin	TYPE 6
23	LEDB2	O	LED blue 2 current output pin	TYPE 6
24	LEDR3	O	LED red 3 current output pin	TYPE 6
25	LEDG3	O	LED green 3 current output pin	TYPE 6
26	LEDB3	O	LED blue 3 current output pin	TYPE 6
27	LEDR4	O	LED red 4 current output pin	TYPE 6
28	LEDG4	O	LED green 4 current output pin	TYPE 6
29	LEDB4	O	LED blue 4 current output pin	TYPE 6
30	PGND2	-	GND pin dedicated for LED driver. Connect directly to ground plane	
31	LEDR5	O	LED red 5 current output pin	TYPE 6
32	LEDG5	O	LED green 5 current output pin	TYPE 6
33	LEDB5	O	LED blue 5 current output pin	TYPE 6
34	LVCC	-	Protection for LED drivers. For higher LED voltages. LVCC must be limited to 42.0 V (max)	
35	LEDR6	O	LED red 6 current output pin	TYPE 6
36	LEDG6	O	LED green 6 current output pin	TYPE 6

# LV52511MNZ

## PIN DESCRIPTIONS (continued)

Pin No.	Pin Name	I/O	Description	Pin Circuit
37	LEDB6	O	LED blue 6 current output pin	TYPE 6
38	LEDR7	O	LED red 7 current output pin	TYPE 6
39	LEDG7	O	LED green 7 current output pin	TYPE 6
40	LEDB7	O	LED blue 7 current output pin	TYPE 6
41	PGND3	-	GND pin dedicated for LED driver. Connect directly to ground plane	
42	LEDR8	O	LED red 8 current output pin	TYPE 6
43	LEDG8	O	LED green 8 current output pin	TYPE 6
44	LEDB8	O	LED blue 8 current output pin	TYPE 6
45	SDO	O	Serial interface output pin.	TYPE 7
46	SDEN	I	Active high, 3-wire SPI Mode enable signal. Must go low after each SPI frame. Not used for 2 wire interface	TYPE 8
47	SDATA	I/O	Serial interface data input / output pin. Data frame consists of: Slave_Address[7:0] – Register_Address[7:0] – Data1[7:0] ... DataN[7:0]	TYPE 9
48	SCLK	I	Serial interface clock signal input pin. Data is latched at the rising clock edge	TYPE 10
	Exposed PAD		Connected to ground plane	

## PIN CIRCUIT

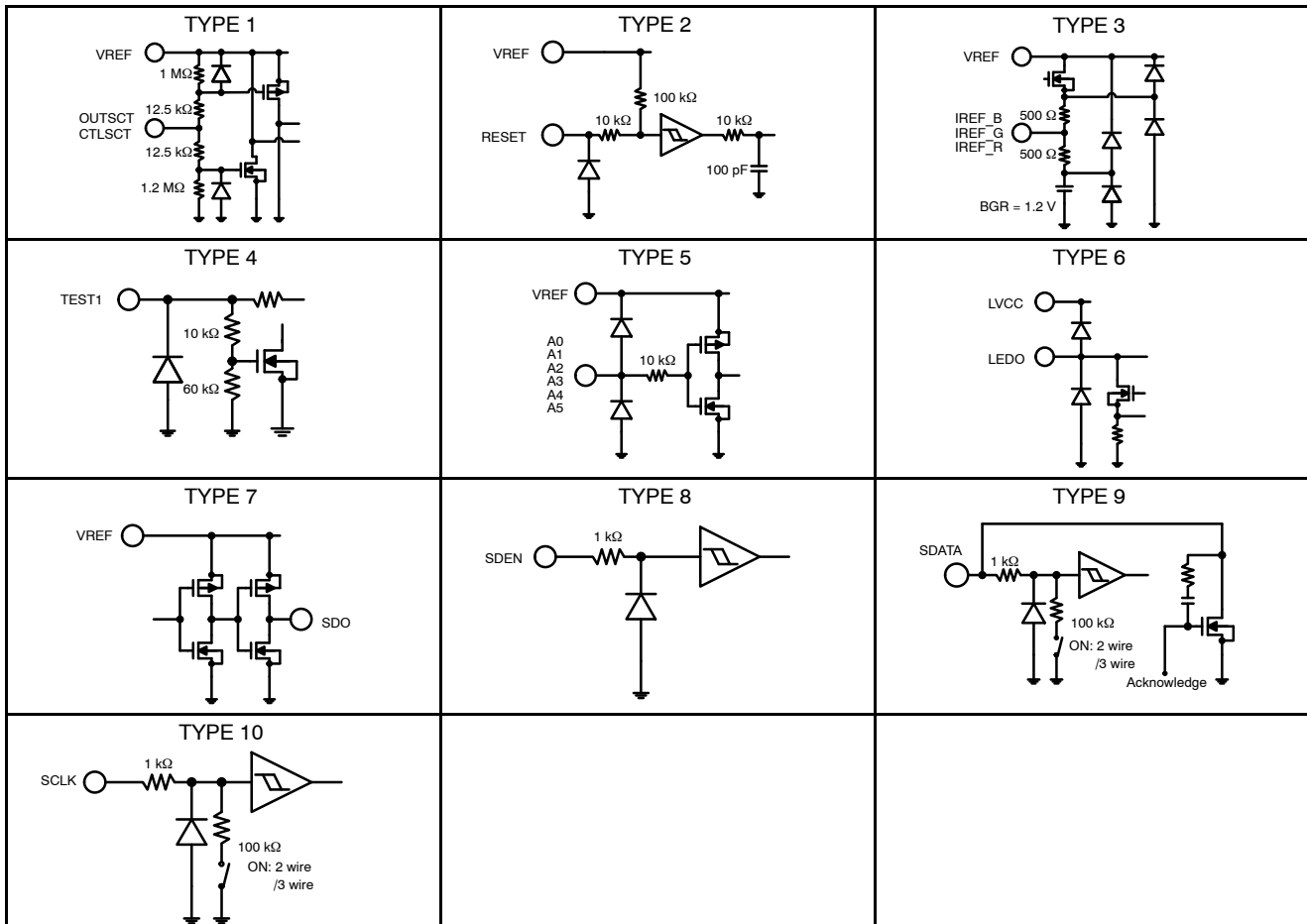

# LV52511MNZ

## SPECIFICATIONS

### ABSOLUTE MAXIMUM RATINGS (Note 2)

Symbol	Parameter	Conditions	Ratings	Unit
V <sub>CC</sub> max	Maximum Supply Voltage		24	V
V <sub>LED</sub>			42	V
V <sub>REF</sub>			5.8	V
V <sub>O</sub> max	Output Voltage	LED off	42	V
I <sub>O</sub> max	Output Current	SV <sub>CC</sub> = 5.0 to 20 V	60/80	mA
I <sub>O</sub> max	Output Current	SV <sub>CC</sub> = 3.0 to 5 V	30/80	mA
P <sub>d</sub> max	Allowable Power Dissipation	T <sub>A</sub> ≤ 25°C (Note 1)	4.15	W
T <sub>opr</sub>	Operating Temperature		-25 to +85	°C
T <sub>j</sub>	Operating Junction Temperature		-25 to +150	°C
T <sub>stg</sub>	Storage Temperature		-40 to +150	°C

Stresses exceeding those listed in the Maximum Ratings table may damage the device. If any of these limits are exceeded, device functionality should not be assumed, damage may occur and reliability may be affected.

1. Specified board: 110 mm × 90 mm × 1.6 mm, glass epoxy board. Exposed Die-pad area is not a substrate mounting.
2. If you should intend to use this IC continuously under high temperature, high current, high voltage, or drastic temperature change, even if it is used within the range of absolute maximum ratings or operating conditions, there is a possibility of decrease reliability. Please contact us for a confirmation.

### RECOMMENDED OPERATING CONDITIONS

Symbol	Parameter	Conditions	Ratings	Unit
V <sub>CC</sub> op	Operating Supply Voltage Range	SV <sub>CC</sub>	3.0 to 20	V
V <sub>LED</sub> op		LV <sub>CC</sub>	3.0 to 41	V
V <sub>REF</sub> op		V <sub>REF</sub>	3.0 to 5.5	V

Functional operation above the stresses listed in the Recommended Operating Ranges is not implied. Extended exposure to stresses beyond the Recommended Operating Ranges limits may affect device reliability.

### ELECTRICAL CHARACTERISTICS (T<sub>A</sub> = 25°C, 3.3 V < SV<sub>CC</sub> < 20 V)

Symbol	Parameter	Conditions	Min	Typ	Max	Unit
I <sub>CC1</sub>	Supply Current1	SV <sub>CC</sub> = 12 V/RESET = H LED OFF	1.2	1.9	2.6	mA
I <sub>CC2</sub>	Supply Current2	SV <sub>CC</sub> = 12 V/RESET = H LED OFF SCLK = 5 MHz	1.8	3.0	4.2	mA
IMAX1R	LED Driver Output Current Rch	I <sub>ref-R</sub> = 27 kΩ, OUTSCT = L	24.25	25.80	27.35	mA
IMAX1G	LED Driver Output Current Gch	I <sub>ref-G</sub> = 27 kΩ, OUTSCT = L	24.25	25.80	27.35	mA
IMAX1B	LED Driver Output Current Bch	I <sub>ref-B</sub> = 27 kΩ, OUTSCT = L	24.25	25.80	27.35	mA
ΔIL	Line Regulation	V <sub>O</sub> = 0.7 to 4.0 V (Same channel line regulation)	-5	-	-	%
R <sub>on1</sub>	LED Output on Resistance 1	I <sub>O</sub> = 10 mA	-	10	20	Ω
I <sub>leak</sub>	OFF Leak Current	LED OFF	-	-	1	μA
VPOR	VCC Power on RESET Voltage	POR release voltage threshold	-	2.5	-	V
VRST		Undervoltage lockout threshold	-	2.3	-	V
VREF1	VREF Voltage	SV <sub>CC</sub> = 12 V, I <sub>O</sub> = 30 mA	4.8	5.1	5.4	V

Product parametric performance is indicated in the Electrical Characteristics for the listed test conditions, unless otherwise noted. Product performance may not be indicated by the Electrical Characteristics if operated under different conditions.

## LV52511MNZ

### CONTROL CIRCUIT ( $T_A = 25^\circ\text{C}$ , $\text{SVCC} = 5.0$ to $20$ V)

Symbol	Parameter	Conditions	Min	Typ	Max	Unit
VH1	H Level 1	Input H level OUTSCT/CTLSCT	4.5	–	5.0	V
VM1	M Level 1	Input M level OUTSCT/CTLSCT	1.8	–	3.0	V
VL1	L Level 1	Input L level OUTSCT/CTLSCT	0	–	0.5	V
VH2	H Level 2	Input H level RESET	4.0	–	5.0	V
VL2	L Level 2	Input L level RESET	0	–	1.0	V
VH3	H Level 3	Input H level A0 to A5	3.5	–	5.0	V
VL3	L Level 3	Input L level A0 to A5	0	–	0.5	V
VH4	H Level 4	Input H level SCLK, SDATA, SDEN	4.0	–	5.0	V
VL4	L Level 4	Input L level SCLK, SDATA, SDEN	0	–	1.0	V

### CONTROL CIRCUIT ( $T_A = 25^\circ\text{C}$ , $\text{SVCC} = 3.3$ V)

Symbol	Parameter	Conditions	Min	Typ	Max	Unit
VH1	H Level 1	Input H level OUTSCT/CTLSCT	2.8	–	3.3	V
VM1	M Level 1	Input M level OUTSCT/CTLSCT	1.2	–	1.8	V
VL1	L Level 1	Input L level OUTSCT/CTLSCT	0	–	0.5	V
VH2	H Level 2	Input H level RESET	2.7	–	3.3	V
VL2	L Level 2	Input L level RESETT	0	–	0.6	V
VH3	H Level 3	Input H level A0 to A5	2.7	–	3.3	V
VL3	L Level 3	Input L level A0 to A5	0	–	0.5	V
VH4	H Level 4	Input H level SCLK, SDATA, SDEN	2.7	–	3.3	V
VL4	L Level 4	Input L level SCLK, SDATA, SDEN	0	–	0.6	V

## LV52511MNZ

### SERIAL BUS TIMING CONDITIONS AT 2-WIRE SPI, AND 3-WIRE SPI

Symbol	Parameter	Conditions	Min	Typ	Max	Unit
ts0	Data Setup Time	SDEN setup time relative to the rise of SCLK	90	–	–	ns
ts1		SDATA setup time relative to the rise of SCLK	60	–	–	ns
th0	Data Hold Time	SDEN hold time relative to the fall of SCLK	200	–	–	ns
th1		SDATA hold time relative to the fall of SCLK	60	–	–	ns
tw1L	Pulse Width	Low period pulse width of SCLK	90	–	–	ns
tw1H		High period pulse width of SCLK	90	–	–	ns
tw2L		Low period pulse width of SDEN	1	–	–	μs

### SERIAL BUS TIMING CONDITIONS AT I<sup>2</sup>C FAST-MODE PLUS

Symbol	Parameter	Conditions	Min	Typ	Max	Unit
fsc1	SCL Clock Frequency	SCLK clock frequency	0	–	1000	kHz
ts1	Data Setup Time	SCL setup time relative to the rise of SDA	0.26	–	–	μs
ts2		SDA setup time relative to the rise of SCL	50	–	–	ns
ts3		SCL setup time relative to the rise of SDA	0.26	–	–	μs
th1	Data Hold Time	SCL hold time relative to the fall of SDA	–	–	–	μs
th2		SDA hold time relative to the fall of SCL	0	–	–	μs
tw1L	Pulse Width	Low period pulse width of SCL	0.5	–	–	μs
tw1H		High period pulse width of SCL	0.26	–	–	μs
ton	Input Signal	Rise time of both SDA and SCL signals	–	–	120	ns
tof		Fall time of both SDA and SCL signals	–	–	120	ns
tbuf	Bus Free Time	Bus free time between a STOP and START condition	0.5	–	–	μs

### SERIAL BUS TIMING CONDITIONS AT I<sup>2</sup>C Hs-MODE

Symbol	Parameter	Conditions	Min	Typ	Max	Unit
fsc1	SCL Clock Frequency	SCLK clock frequency	0	–	3.4	MHz
ts1	Data Setup Time	SCL setup time relative to the rise of SDA	160	–	–	ns
ts2		SDA setup time relative to the rise of SCL	10	–	–	ns
ts3		SCL setup time relative to the rise of SDA	160	–	–	ns
th1	Data Hold Time	SCL hold time relative to the fall of SDA	–	–	–	ns
th2		SDA hold time relative to the fall of SCL	0	–	70	ns
tw1L	Pulse Width	Low period pulse width of SCL	160	–	–	ns
tw1H		High period pulse width of SCL	60	–	–	ns
tcon	Input Signal	Rise time of SCL signals	10	–	40	ns
tcof		Fall time of SCL signals	10	–	40	ns
tdon		Rise time of SDA signals	10	–	80	ns
Tdof		Fall time of SDA signals	10	–	80	ns

The ACK sink capability of the SDA pin is equal to FASTMODE. In case of requirement up to 20 mA, an external MOSFET is needed.

# LV52511MNZ

## DETAILED FUNCTIONAL DESCRIPTION

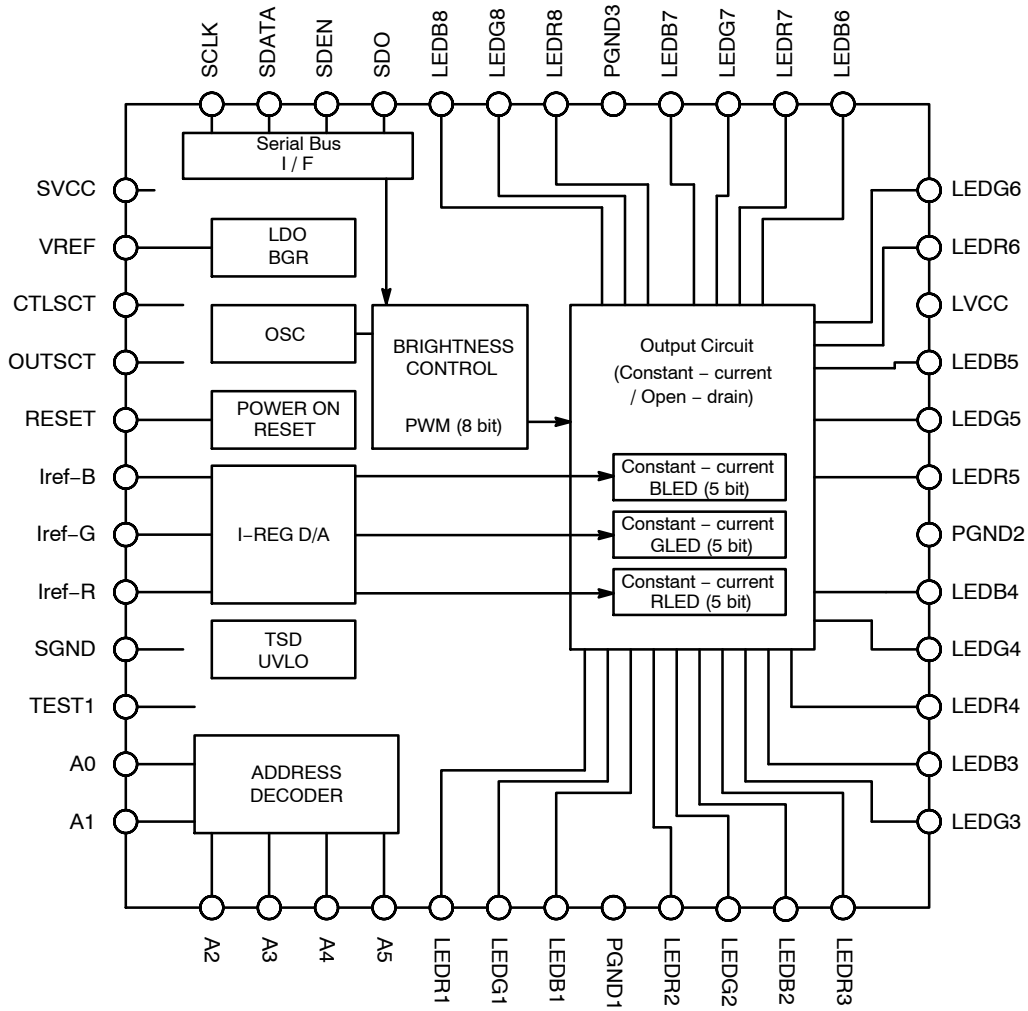

Figure 3. Block Diagram



# LV52511MNZ

## System Startup and Shutdown (SVCC, RESET)

The LV52511MN is supplied via SVCC. If the voltage on SVCC rises above the POR level of 2.5 V (typ) the system

setup registers are being reset to their default state, and the reference internal reference circuit at VREF starts up.

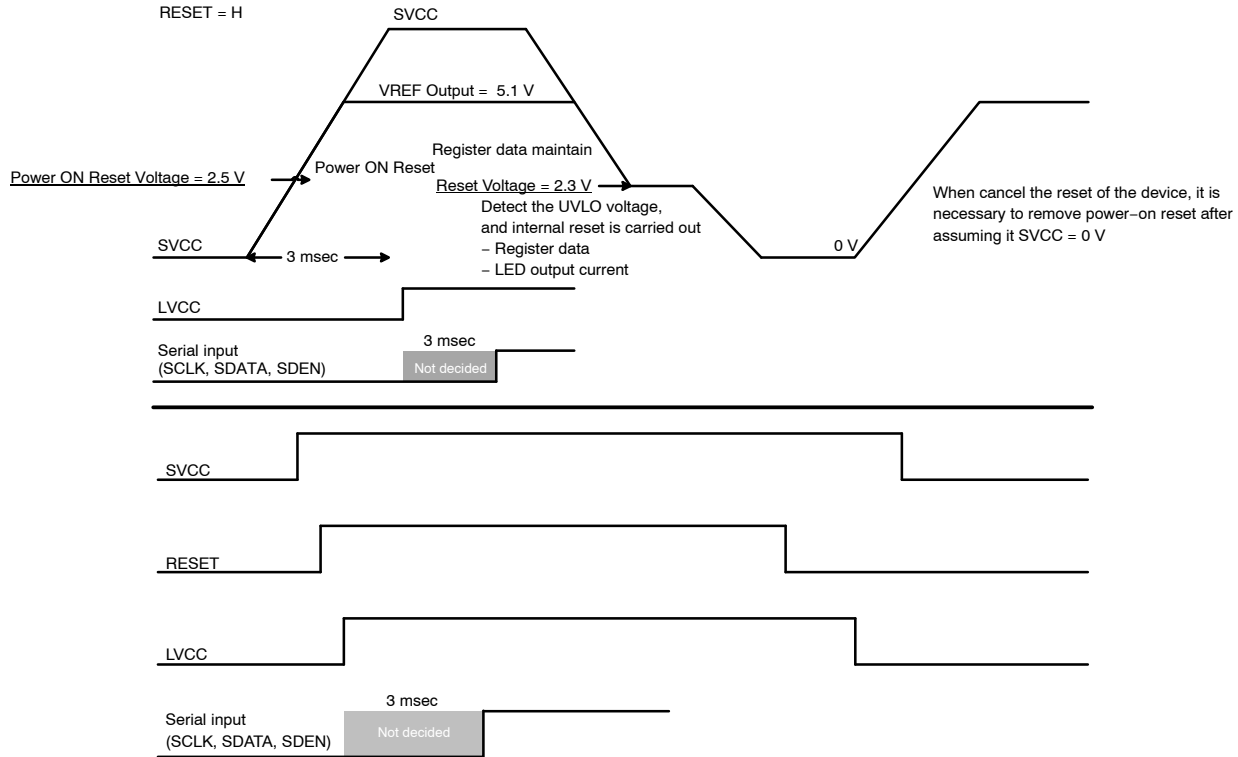

Figure 4. SVCC Startup and Shutdown

SVCC can be connected to the LED supply of the application as long as that supply is between 3 and 20 V. If the LED supply is higher than 20 V, SVCC must be supplied from a separate source.

If SVCC drops below the undervoltage lockout level of 2.3 V (typ) the system shuts down.

## Internal References (SVCC, VREF, Iref-R/G/B)

An internal voltage reference of 5 V (typ) is generated at VREF from SVCC. Do not connect external loads.

An LED reference current is defined by connecting a resistor  $R_{RT}$  between Iref-R/G/B and GND according to the formula:  $I_{MAX} = 1.2 \times 580 / R_{RT}$ . A fraction of this current (3%–100%) is applied to each LED channel.

Table 1. INTERNAL REFERENCES

Iref-R/G/B Setting	Serial Setting Pin
Iref-R: resistance Iref-G: VREF Iref-B: VREF	The variable adjustment of the RGB electric current level by the register is possible by connecting resistance to decide a current value to only Iref-R. (for 00h for 01h 02h) Iref-G, Iref-B connects with VREF terminal.
Iref-R: resistance Iref-G: resistance Iref-B: resistance	The current value of RGB is fixed by connecting resistance to decide a current value to RGB unit. The adjustment of the register is not possible (it becomes fixed in max)

# LV52511MNZ

## LED Driver Configuration (LEDR1–8, LEDG1–8, LEDB1–8, OUTSCT)

The LEDs are connected between the system LED supply and IC channels LED\_R1–R8, LED\_G1–G8, LED\_B1–B8 such that the LED current flows into the IC. Depending on the LED drive voltage, it is possible to connect a single LED or a chain of LEDs.

The LV52511MN can adjust color temperature and brightness for up to 24 LEDs. Color temperature is adjusted by varying the LED current, and brightness (luminance) is adjusted by varying the on-time of the LED a fixed time period (duty-cycle).

### Color Temperature Control

The 24 LED channels are organized into 3 color groups (Red, Green, Blue) of 8 channels each. The currents for each color group are programmed by a 5 bit register as

a percentage of the LED reference current  $I_{MAX}$ . Percentages of 3 to 100 are possible.

### Luminance Control

The brightness of each LED channel is defined by the duty cycle Duty(%): the time  $t_{ON}$  the channel is active during a time window  $t_{CYCLE}$ . The duty cycle is defined by the following formula.  $Duty(\%) = 100 \times t_{ON} / t_{CYCLE}$ . Each LED channel has an 8-bit register to vary the duty cycle between OFF (0.0%) and 99.6% in steps of 0.39% each.

### OUTSCT Settings

In addition to the settings mentioned above, it is also possible to subdivide the 8 LED channels within the color groups into 6 and 2 LED channels grouped in the following way:

**Table 2. OUTSCT SETTINGS**

OUTSCT Level	LED Driver Output Pin	
	LEDR1–R6, LEDG1–G6, LEDB1–B6	LEDR7/R8, LEDG7/G8, LEDB7/B8
L = -0.2 to 0.3 V	Constant current output Set maximum current by built-in D/A (5 bits) 0.81 mA to 25.8 mA, $RT1 = 27 \text{ k}\Omega$	Same as the other LEDs
H = 4.7 to 5.0 V	Open drain output Set current by external resistor $R_{ON} = 10 \Omega$	Same as the other LEDs
M = 1.8 to 3.0 V	Constant current output Set maximum current by built-in D/A (5 bits) 0.81 mA to 25.8 mA, $RT1 = 27 \text{ k}\Omega$	Open drain output Set current by external resistor $R_{ON} = 10 \Omega$

## Thermal Considerations

Supplying a large number of LEDs from the LV52511MN leads to a rise in chip temperature. The self-heating depends on:

- the drive current  $I_O$  flowing into the LED channel
- the voltage at the output  $V_{OUT}$  of the LED channel
- and the duty cycle  $D$  they are driven with leading to the following formula for dissipated power in each channel:

$$P_{CH} = I_O \times V_{OUT} \times D \quad (\text{eq. 1})$$

The only architecture sensitive value is  $V_{OUT}$ . It must be greater than 0.7 V (min) to allow for regulation, but also as small as possible. It is therefore advisable to connect the maximum possible number of LEDs in series to one channel.

The total power dissipation  $P_{TOT}$  of the IC is then the sum of all  $P_{CH}$  together.  $P_{TOT}$  must not exceed the power allowed by the safe operating area shown in Figure 5.

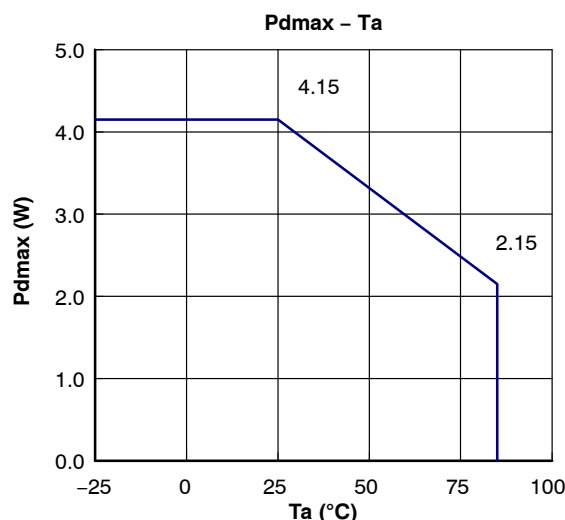

**Figure 5. Safe Operating Area**

# LV52511MNZ

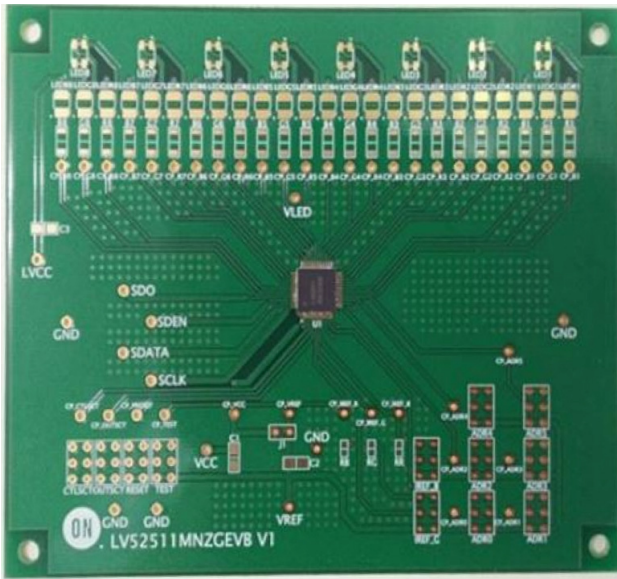

Figure 6. Board

### Over Temperature Shutoff

To protect the circuit from permanent damage or fire, overtemperature shutoff is implemented. If the junction temperature of the IC reaches 175°C, all LED outputs are turned OFF. The thermal shut down is not latched, so when the temperature falls below 130°C activity resumes.

### Serial Bus Communication (SCLK, SDATA, SDEN, CTLST)

All parameters described above are written to the LV52511MN via a single directional 2-wire or 3-wire serial bus with a clock frequency of up to 5 MHz. The bus type is defined by the state of pin CTLST (VREF = 2-wire, GND = 3-wire). Furthermore, the setting of CTLST = M supports I<sup>2</sup>C. It supports Hs-mode (3.4 MHz).

Each bus message consists of an 8bit slave (IC) address, followed by an 8bit register address, followed by one or more 8bit data words. The register address will self-increment for consecutive data words as long as the communication is valid. After the last address was written, the next data word will be written to address 00h again. For detailed information on addresses and register contents see section”

Table 3. SERIAL SETTING PIN

CTLST Level	Serial Setting Pin
L = -0.2 to 0.3 V	3wire SPI serial bus (SCLK, SDATA, SDEN) 5 MHz
H = 4.7 to 5.0 V	2wire SPI serial bus (SCLK, SDATA) 5 MHz
M = 1.8 to 3.0 V	I <sup>2</sup> C serial bus (SCLK, SDATA) Hs-mode

### Slave Address (A5–A0)

Each IC is identified by its unique slave address. The most significant two bits of the 8bit slave (IC) address are fixed to 10b. 56 Slave addresses are hardware defined by pins A0–A5 as described below.

Table 4. SLAVE ADDRESS (A5–A0)

	SA7	SA6	SA5	SA4	SA3	SA2	SA1	SA0
ADDRESS	1	A5	A4	A3	A2	A1	A0	0

Terminal PIN (Input)						SLAVE ADDRESS							
A5	A4	A3	A2	A1	A0	SA7	SA6	SA5	SA4	SA3	SA2	SA1	SA0
L	L	L	L	L	L	1	0	0	0	0	0	0	0
...						1	A5	A4	A3	A2	A1	A0	0
H	H	L	H	H	H	1	1	1	0	1	1	1	0

At the time of CTLST = L, H, the SLAVE setting is possible to 56.

At the time of CTLST = M, the SLAVE setting is possible to 48.

3-wire Serial Bus Communication  
(SCLK, SDATA, and SDEN)

In 3-wire communication a frame is started with a rising edge of SDEN and terminated with a falling edge of SDEN. SCLK latches data at the rising edge. The smallest data word is 24bits long consisting of:

If the number of SCLK transitions is less than 23, Data is not latched. If it is 25 or more, the register address is automatically incremented and the next data word will be latched after eight clock cycles.

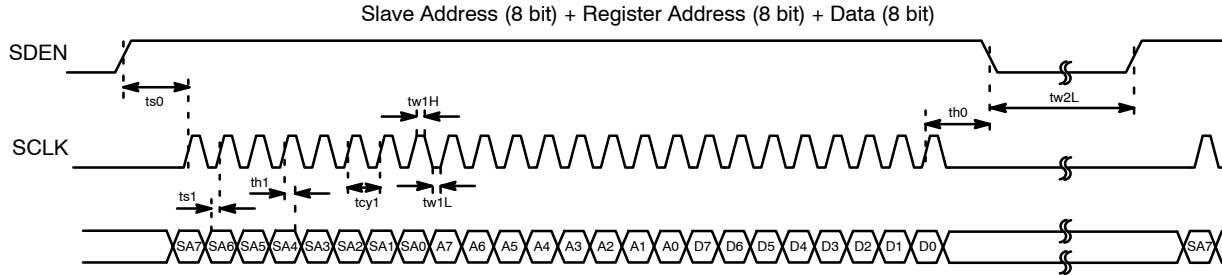

Figure 7. 3-wire Serial Data Frame

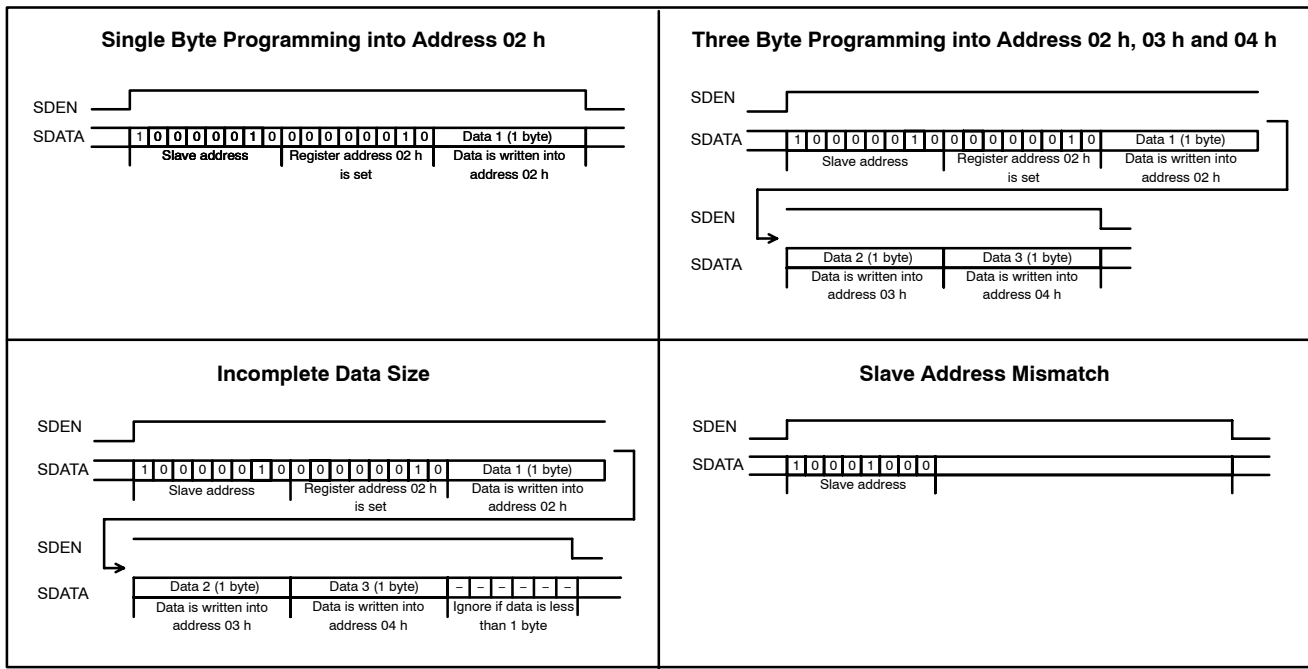

Figure 8. Data Write Examples into Slave 82h

# LV52511MNZ

## 2-wire Serial Bus Communication (SCLK, SDATA)

In 2-wire communication the LV52511MN watches SDATA at every rising SCLK edge. A data frame begins after START condition: nine consecutive detections of a “1” (high) followed by a “0” (BLANK). This is true even during an ongoing data transfer: serial communication will be restarted by a START condition (“11111111”) + BLANK (“0”).

After start detection, the eight bit slave address will be latched after receiving a BLANK (0h) with the ninth bit. The register address will be latched after receiving a BLANK “0”

after eight address bits. The third byte is the data byte which was addressed by the register address received before. The data byte will be latched after receiving a BLANK “0” in position nine after eight data bits.

When data bytes continue after this, the register address will be automatically incremented after each byte transfer is completed after receiving BLANK “0”.

If the BLANK after a data transfer is “1”, including slave address and register address, the single byte data just before it will not be written, and subsequent data is ignored until another START condition is detected.

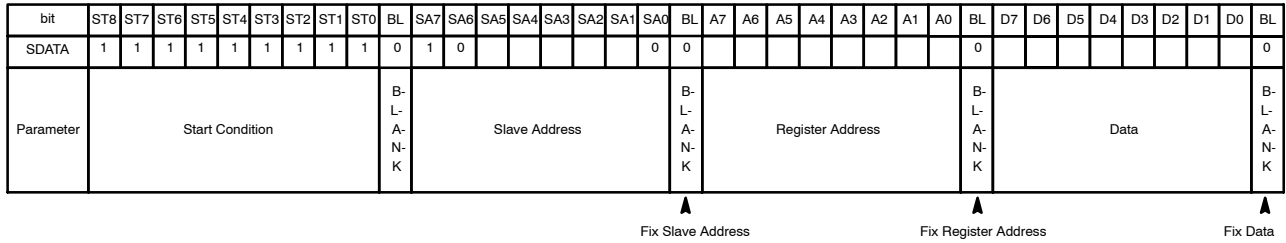

**Figure 9. 2-wire Serial Communication Frame**

Minimum Data length is 37 bits:  
 Start condition “11111111” (9bit) + BLANK (“0”) +  
 Slave address (8bit) + BLANK (“0”) +  
 Register address (8bit) + BLANK (“0”) +  
 Data (8bit) + BLANK (“0”).

**NOTE:** When SCLK is less than 27th clocks and/or BLANK is “1” instead of “0” after start detection, will not take in SDATA. When SCLK is higher than 28th clock track, start detection is confirmed, register address is incremented every 1 byte (8bit) + BLANK (“0”).

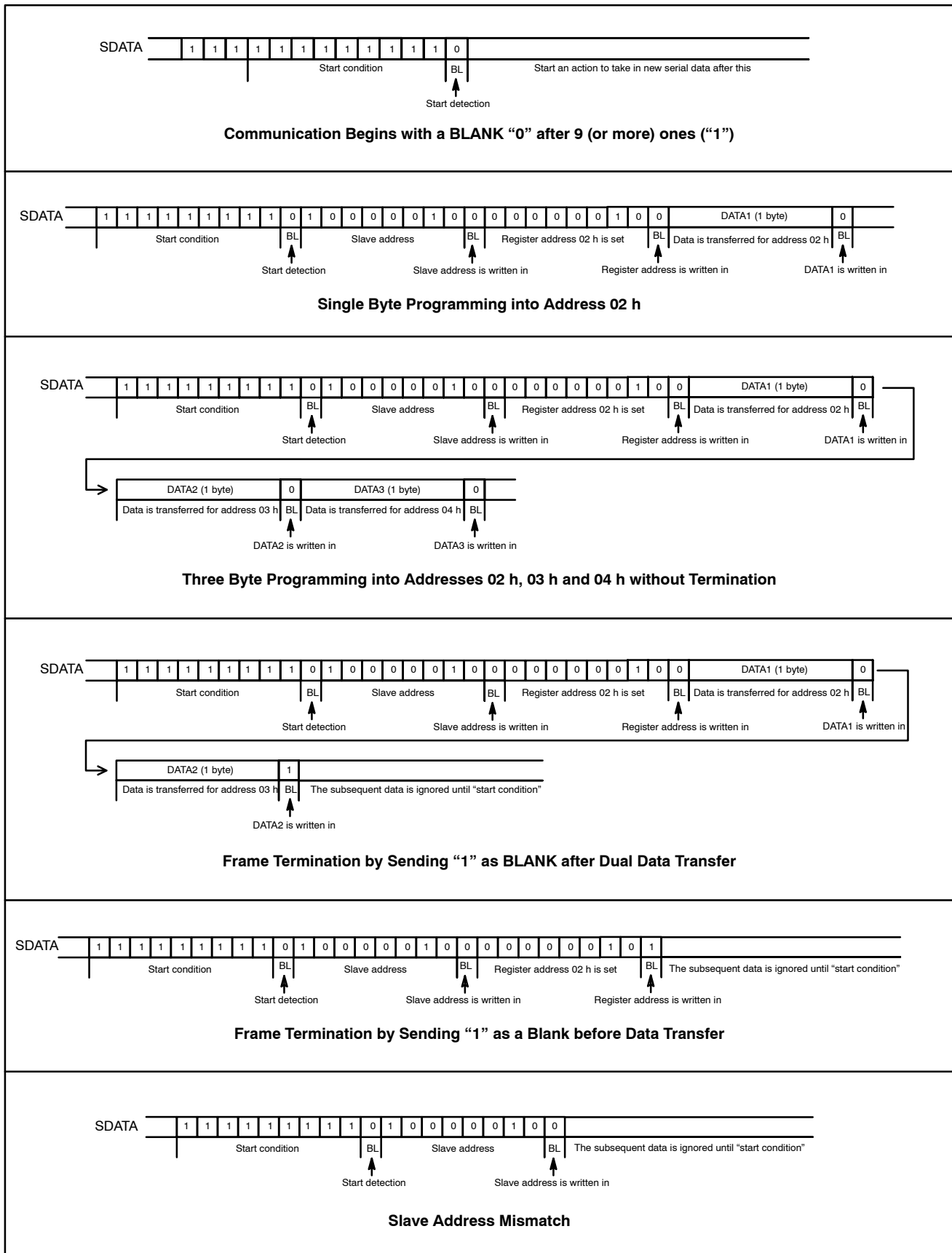

Figure 10. Data Write Examples into Slave 82h

# LV52511MNZ

## I<sup>2</sup>C Serial Bus Communication (SCLK, SDATA)

In 2-wire communication, LV52511MN accepts the format corresponding to the standard of I<sup>2</sup>C.

It is Fast-mode Plus and higher-speed communicating Hs-mode.

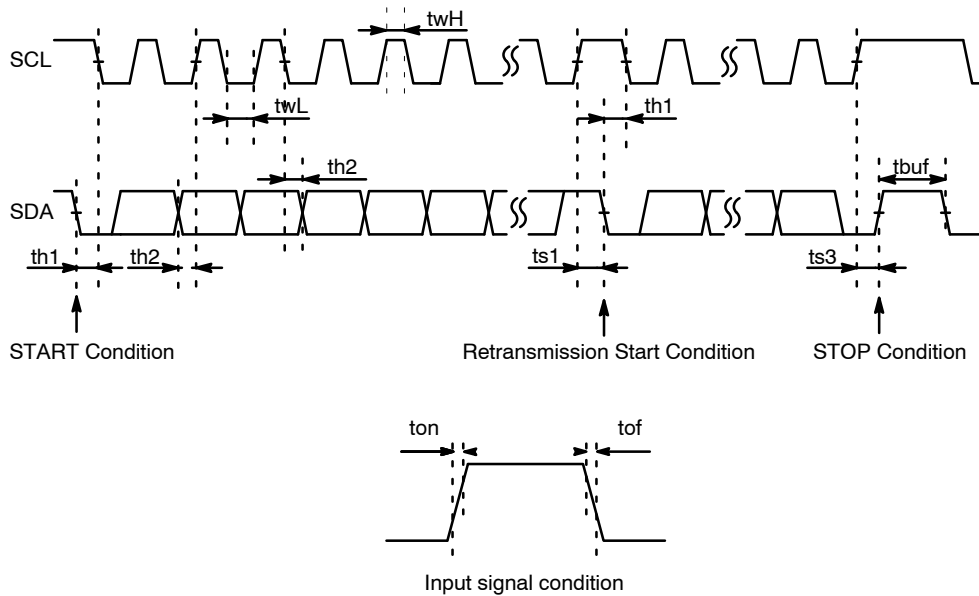

Figure 11.

As for start condition and the stop condition I<sup>2</sup>C bus, SCL has that SDA is kept between “H” by the constant state like the chart below during movement performing data transmission basically.

In addition, SCL and SDA are in a condition of “H” together when data transmission is not carried out. It becomes, and, at the time of this SCL = SDA = H, access is started by a start condition when I change SDA into L from H.

When SCL changes SDA into “H” from “L” at the time of H, it becomes a stop condition and becomes the end of the access.

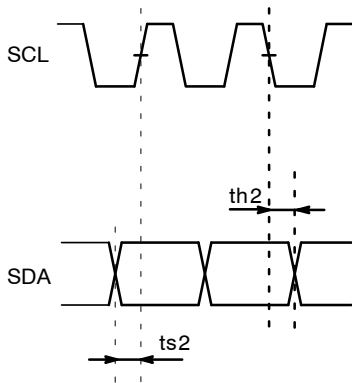

Figure 12.

The READ mode does not support.

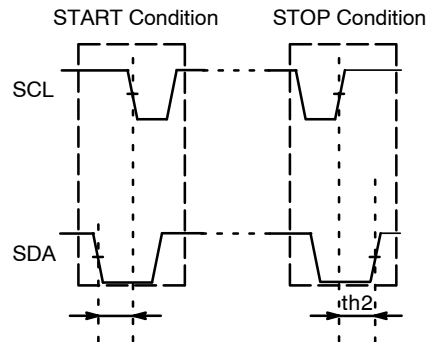

Figure 13.

# LV52511MNZ

## REGISTER MAP

After POR all registers are cleared.

**Table 5. COLOR TEMPERATURE REGISTERS**

Addr.	Register	D[7]	D[6]	D[5]	D[4]	D[3]	D[2]	D[1]	D[0]	Description	
00h	LEDR Current				I_LEDR[4:0]				LEDR Current Setting (LEDR1~LEDR8)		
		0	0	0	0	0	0	0	0	3% of I <sub>max</sub>	(0.81 mA @ RT = 27 kΩ)
		0	0	0	0	0	0	0	1	6% of I <sub>max</sub>	(1.61 mA @ RT = 27 kΩ)
		0	0	0	0	0	0	1	0	9% of I <sub>max</sub>	(2.42 mA @ RT = 27 kΩ)
		0	0	0	0	0	0	1	1	13% of I <sub>max</sub>	(3.23 mA @ RT = 27 kΩ)
		0	0	0	0	0	1	0	0	16% of I <sub>max</sub>	(4.03 mA @ RT = 27 kΩ)
		0	0	0	0	0	1	0	1	19% of I <sub>max</sub>	(4.84 mA @ RT = 27 kΩ)
		0	0	0	0	0	1	1	0	22% of I <sub>max</sub>	(5.64 mA @ RT = 27 kΩ)
		0	0	0	0	0	1	1	1	25% of I <sub>max</sub>	(6.45 mA @ RT = 27 kΩ)
		0	0	0	0	1	0	0	0	28% of I <sub>max</sub>	(7.26 mA @ RT = 27 kΩ)
		0	0	0	0	1	0	0	1	31% of I <sub>max</sub>	(8.06 mA @ RT = 27 kΩ)
		0	0	0	0	1	0	1	0	34% of I <sub>max</sub>	(8.87 mA @ RT = 27 kΩ)
		0	0	0	0	1	0	1	1	38% of I <sub>max</sub>	(9.68 mA @ RT = 27 kΩ)
		0	0	0	0	1	1	0	0	41% of I <sub>max</sub>	(10.48 mA @ RT = 27 kΩ)
		0	0	0	0	1	1	0	1	44% of I <sub>max</sub>	(11.29 mA @ RT = 27 kΩ)
		0	0	0	0	1	1	1	0	47% of I <sub>max</sub>	(12.09 mA @ RT = 27 kΩ)
		0	0	0	0	1	1	1	1	50% of I <sub>max</sub>	(12.90 mA @ RT = 27 kΩ)
		0	0	0	0	1	0	0	0	53% of I <sub>max</sub>	(13.71 mA @ RT = 27 kΩ)
		0	0	0	0	1	0	0	1	56% of I <sub>max</sub>	(14.51 mA @ RT = 27 kΩ)
		0	0	0	0	1	0	0	1	59% of I <sub>max</sub>	(15.32 mA @ RT = 27 kΩ)
		0	0	0	0	1	0	0	1	63% of I <sub>max</sub>	(16.13 mA @ RT = 27 kΩ)
		0	0	0	0	1	0	1	0	66% of I <sub>max</sub>	(16.93 mA @ RT = 27 kΩ)
		0	0	0	0	1	0	1	0	69% of I <sub>max</sub>	(17.74 mA @ RT = 27 kΩ)
		0	0	0	0	1	0	1	1	72% of I <sub>max</sub>	(18.54 mA @ RT = 27 kΩ)
		0	0	0	0	1	0	1	1	75% of I <sub>max</sub>	(19.35 mA @ RT = 27 kΩ)
		0	0	0	0	1	1	0	0	78% of I <sub>max</sub>	(20.16 mA @ RT = 27 kΩ)
		0	0	0	0	1	1	0	0	81% of I <sub>max</sub>	(20.96 mA @ RT = 27 kΩ)
		0	0	0	0	1	1	0	1	84% of I <sub>max</sub>	(21.77 mA @ RT = 27 kΩ)
		0	0	0	0	1	1	0	1	88% of I <sub>max</sub>	(22.58 mA @ RT = 27 kΩ)
		0	0	0	0	1	1	1	0	91% of I <sub>max</sub>	(23.38 mA @ RT = 27 kΩ)
0	0	0	0	1	1	1	0	94% of I <sub>max</sub>	(24.19 mA @ RT = 27 kΩ)		
0	0	0	0	1	1	1	1	97% of I <sub>max</sub>	(24.99 mA @ RT = 27 kΩ)		
0	0	0	0	1	1	1	1	I <sub>max</sub>	(25.80 mA @ RT = 27 kΩ)		
01h	LEDG Current				I_LEDG[4:0]				LEDG Current Setting (LEDG1~LEDG8)		
		0	0	0	0	0	0	0	0	3% of I <sub>max</sub>	(0.81 mA @ RT = 27 kΩ)
		0	0	0	0	0	0	0	1	6% of I <sub>max</sub>	(1.61 mA @ RT = 27 kΩ)
		0	0	0	0	0	0	1	0	9% of I <sub>max</sub>	(2.42 mA @ RT = 27 kΩ)
		0	0	0	0	0	0	1	1	13% of I <sub>max</sub>	(3.23 mA @ RT = 27 kΩ)
		0	0	0	0	0	1	0	0	16% of I <sub>max</sub>	(4.03 mA @ RT = 27 kΩ)
		0	0	0	0	0	1	0	1	19% of I <sub>max</sub>	(4.84 mA @ RT = 27 kΩ)
		0	0	0	0	0	1	1	0	22% of I <sub>max</sub>	(5.64 mA @ RT = 27 kΩ)



# LV52511MNZ

**Table 5. COLOR TEMPERATURE REGISTERS** (continued)

Addr.	Register	D[7]	D[6]	D[5]	D[4]	D[3]	D[2]	D[1]	D[0]	Description	
		0	0	0	0	0	1	1	1	25% of I <sub>max</sub>	(6.45 mA @ RT = 27 kΩ)
		0	0	0	0	1	0	0	0	28% of I <sub>max</sub>	(7.26 mA @ RT = 27 kΩ)
		0	0	0	0	1	0	0	1	31% of I <sub>max</sub>	(8.06 mA @ RT = 27 kΩ)
		0	0	0	0	1	0	1	0	34% of I <sub>max</sub>	(8.87 mA @ RT = 27 kΩ)
		0	0	0	0	1	0	1	1	38% of I <sub>max</sub>	(9.68 mA @ RT = 27 kΩ)
		0	0	0	0	1	1	0	0	41% of I <sub>max</sub>	(10.48 mA @ RT = 27 kΩ)
		0	0	0	0	1	1	0	1	44% of I <sub>max</sub>	(11.29 mA @ RT = 27 kΩ)
		0	0	0	0	1	1	1	0	47% of I <sub>max</sub>	(12.09 mA @ RT = 27 kΩ)
		0	0	0	0	1	1	1	1	50% of I <sub>max</sub>	(12.90 mA @ RT = 27 kΩ)
		0	0	0	1	0	0	0	0	53% of I <sub>max</sub>	(13.71 mA @ RT = 27 kΩ)
		0	0	0	1	0	0	0	1	56% of I <sub>max</sub>	(14.51 mA @ RT = 27 kΩ)
		0	0	0	1	0	0	1	0	59% of I <sub>max</sub>	(15.32 mA @ RT = 27 kΩ)
		0	0	0	1	0	0	1	1	63% of I <sub>max</sub>	(16.13 mA @ RT = 27 kΩ)
		0	0	0	1	0	1	0	0	66% of I <sub>max</sub>	(16.93 mA @ RT = 27 kΩ)
		0	0	0	1	0	1	0	1	69% of I <sub>max</sub>	(17.74 mA @ RT = 27 kΩ)
		0	0	0	1	0	1	1	0	72% of I <sub>max</sub>	(18.54 mA @ RT = 27 kΩ)
		0	0	0	1	0	1	1	1	75% of I <sub>max</sub>	(19.35 mA @ RT = 27 kΩ)
		0	0	0	1	1	0	0	0	78% of I <sub>max</sub>	(20.16 mA @ RT = 27 kΩ)
		0	0	0	1	1	0	0	1	81% of I <sub>max</sub>	(20.96 mA @ RT = 27 kΩ)
		0	0	0	1	1	0	1	0	84% of I <sub>max</sub>	(21.77 mA @ RT = 27 kΩ)
		0	0	0	1	1	0	1	1	88% of I <sub>max</sub>	(22.58 mA @ RT = 27 kΩ)
		0	0	0	1	1	1	0	0	91% of I <sub>max</sub>	(23.38 mA @ RT = 27 kΩ)
		0	0	0	1	1	1	0	1	94% of I <sub>max</sub>	(24.19 mA @ RT = 27 kΩ)
		0	0	0	1	1	1	1	0	97% of I <sub>max</sub>	(24.99 mA @ RT = 27 kΩ)
		0	0	0	1	1	1	1	1	I <sub>max</sub>	(25.80 mA @ RT = 27 kΩ)
02h	LEDB Current				_LEDB[4:0]				LEDB Current Setting (LEDB1~LEDB8)		
		0	0	0	0	0	0	0	0	3% of I <sub>max</sub>	(0.81 mA @ RT = 27 kΩ)
		0	0	0	0	0	0	0	1	6% of I <sub>max</sub>	(1.61 mA @ RT = 27 kΩ)
		0	0	0	0	0	0	1	0	9% of I <sub>max</sub>	(2.42 mA @ RT = 27 kΩ)
		0	0	0	0	0	0	1	1	13% of I <sub>max</sub>	(3.23 mA @ RT = 27 kΩ)
		0	0	0	0	0	1	0	0	16% of I <sub>max</sub>	(4.03 mA @ RT = 27 kΩ)
		0	0	0	0	0	1	0	1	19% of I <sub>max</sub>	(4.84 mA @ RT = 27 kΩ)
		0	0	0	0	0	1	1	0	22% of I <sub>max</sub>	(5.64 mA @ RT = 27 kΩ)
		0	0	0	0	0	1	1	1	25% of I <sub>max</sub>	(6.45 mA @ RT = 27 kΩ)
		0	0	0	0	1	0	0	0	28% of I <sub>max</sub>	(7.26 mA @ RT = 27 kΩ)
		0	0	0	0	1	0	0	1	31% of I <sub>max</sub>	(8.06 mA @ RT = 27 kΩ)
		0	0	0	0	1	0	1	0	34% of I <sub>max</sub>	(8.87 mA @ RT = 27 kΩ)
		0	0	0	0	1	0	1	1	38% of I <sub>max</sub>	(9.68 mA @ RT = 27 kΩ)
		0	0	0	0	1	1	0	0	41% of I <sub>max</sub>	(10.48 mA @ RT = 27 kΩ)
		0	0	0	0	1	1	0	1	44% of I <sub>max</sub>	(11.29 mA @ RT = 27 kΩ)
		0	0	0	0	1	1	1	0	47% of I <sub>max</sub>	(12.09 mA @ RT = 27 kΩ)
		0	0	0	0	1	1	1	1	50% of I <sub>max</sub>	(12.90 mA @ RT = 27 kΩ)
		0	0	0	1	0	0	0	0	53% of I <sub>max</sub>	(13.71 mA @ RT = 27 kΩ)
		0	0	0	1	0	0	0	1	56% of I <sub>max</sub>	(14.51 mA @ RT = 27 kΩ)
		0	0	0	1	0	0	1	0	59% of I <sub>max</sub>	(15.32 mA @ RT = 27 kΩ)

# LV52511MNZ

**Table 5. COLOR TEMPERATURE REGISTERS** (continued)

Addr.	Register	D[7]	D[6]	D[5]	D[4]	D[3]	D[2]	D[1]	D[0]	Description	
		0	0	0	1	0	0	1	1	63% of I <sub>max</sub>	(16.13 mA @ RT = 27 kΩ)
		0	0	0	1	0	1	0	0	66% of I <sub>max</sub>	(16.93 mA @ RT = 27 kΩ)
		0	0	0	1	0	1	0	1	69% of I <sub>max</sub>	(17.74 mA @ RT = 27 kΩ)
		0	0	0	1	0	1	1	0	72% of I <sub>max</sub>	(18.54 mA @ RT = 27 kΩ)
		0	0	0	1	0	1	1	1	75% of I <sub>max</sub>	(19.35 mA @ RT = 27 kΩ)
		0	0	0	1	1	0	0	0	78% of I <sub>max</sub>	(20.16 mA @ RT = 27 kΩ)
		0	0	0	1	1	0	0	1	81% of I <sub>max</sub>	(20.96 mA @ RT = 27 kΩ)
		0	0	0	1	1	0	1	0	84% of I <sub>max</sub>	(21.77 mA @ RT = 27 kΩ)
		0	0	0	1	1	0	1	1	88% of I <sub>max</sub>	(22.58 mA @ RT = 27 kΩ)
		0	0	0	1	1	1	0	0	91% of I <sub>max</sub>	(23.38 mA @ RT = 27 kΩ)
		0	0	0	1	1	1	0	1	94% of I <sub>max</sub>	(24.19 mA @ RT = 27 kΩ)
		0	0	0	1	1	1	1	0	97% of I <sub>max</sub>	(24.99 mA @ RT = 27 kΩ)
		0	0	0	1	1	1	1	1	I <sub>max</sub>	(25.80 mA @ RT = 27 kΩ)

**Table 6. LUMINANCE REGISTERS**

Addr.	Register	D[7]	D[6]	D[5]	D[4]	D[3]	D[2]	D[1]	D[0]	Description	
03h	PWM SEL LEDR	R8	R7	R6	R5	R4	R3	R2	R1	Select PWM or Full on for LEDR1~LEDR8	
		0 1	0 1	0 1	0 1	0 1	0 1	0 1	0 1	0: PWM mode 1: Full on (100% PWM)	
04h	PWM SEL LEDG	G8	G7	G6	G5	G4	G3	G2	G1	Select PWM or Full on for LEDG1~LEDG8	
		0 1	0 1	0 1	0 1	0 1	0 1	0 1	0 1	0: PWM mode 1: Full on (100% PWM)	
05h	PWM SEL LEDB	B8	B7	B6	B5	B4	B3	B2	B1	Select PWM or Full on for LEDB1~LEDB8	
		0 1	0 1	0 1	0 1	0 1	0 1	0 1	0 1	0: PWM mode 1: Full on (100% PWM)	
06h	LEDR1 Duty	R1[7]	R1[6]	R1[5]	R1[4]	R1[3]	R1[2]	R1[1]	R1[0]	PWM duty setting for LEDR1	
		0	0	0	0	0	0	0	0	Duty(%) = 0.0%	
		R1[7:0]								Duty(%) = R1[7:0] / 256	
		1	1	1	1	1	1	1	1	Duty(%) = 99.6%	
07h	LEDG1 Duty	G1[7:0]								Duty(%) = G1[7:0] / 256	
08h	LEDB1 Duty	B1[7:0]								Duty(%) = B1[7:0] / 256	
09h	LEDR2 Duty	R2[7:0]								Duty(%) = R2[7:0] / 256	
0ah	LEDG2 Duty	G2[7:0]								Duty(%) = G2[7:0] / 256	
0bh	LEDB2 Duty	B2[7:0]								Duty(%) = B2[7:0] / 256	
0ch	LEDR3 Duty	R3[7:0]								Duty(%) = R3[7:0] / 256	
0dh	LEDG3 Duty	G3[7:0]								Duty(%) = G3[7:0] / 256	
0eh	LEDB3 Duty	B3[7:0]								Duty(%) = B3[7:0] / 256	
0fh	LEDR4 Duty	R4[7:0]								Duty(%) = R4[7:0] / 256	
10h	LEDG4 Duty	G4[7:0]								Duty(%) = G4[7:0] / 256	
11h	LEDB4 Duty	B4[7:0]								Duty(%) = B4[7:0] / 256	
12h	LEDR5 Duty	R5[7:0]								Duty(%) = R5[7:0] / 256	
13h	LEDG5 Duty	G5[7:0]								Duty(%) = G5[7:0] / 256	
14h	LEDB5 Duty	B5[7:0]								Duty(%) = B5[7:0] / 256	
15h	LEDR6 Duty	R6[7:0]								Duty(%) = R6[7:0] / 256	
16h	LEDG6 Duty	G6[7:0]								Duty(%) = G6[7:0] / 256	
17h	LEDB6 Duty	B6[7:0]								Duty(%) = B6[7:0] / 256	

# LV52511MNZ

**Table 6. LUMINANCE REGISTERS** (continued)

Addr.	Register	D[7]	D[6]	D[5]	D[4]	D[3]	D[2]	D[1]	D[0]	Description
18h	LEDR7 Duty	R7[7:0]								Duty(%) = R7[7:0] / 256
19h	LEDG7 Duty	G7[7:0]								Duty(%) = G7[7:0] / 256
1ah	LEDB7 Duty	B7[7:0]								Duty(%) = B7[7:0] / 256
1bh	LEDR8 Duty	R8[7:0]								Duty(%) = R8[7:0] / 256
1ch	LEDG8 Duty	G8[7:0]								Duty(%) = G8[7:0] / 256
1dh	LEDB8 Duty	B8[7:0]								Duty(%) = B8[7:0] / 256
1eh										
1fh										
20h	Group1 Duty	R1/R2/R3/R4/R5/R6/R7/R8[7:0]								Duty(%) = Group1 [7:0] / 256
21h	Group2 Duty	G1/G2/G3/G4/G5/G6/G7/G8[7:0]								Duty(%) = Group2 [7:0] / 256
22h	Group3 Duty	B1/B2/B3/B4/B5/B6/B7/B8[7:0]								Duty(%) = Group3 [7:0] / 256
23h	Group4 Duty	R1/G1/B1/R2/G2/B2[7:0]								Duty(%) = Group4 [7:0] / 256
24h	Group5 Duty	R3/G3/B3/R4/G4/B4[7:0]								Duty(%) = Group5 [7:0] / 256
25h	Group6 Duty	R5/G5/B5/R6/G6/B6[7:0]								Duty(%) = Group6 [7:0] / 256
26h	Group7 Duty	R7/G7/B7/R8/G8/B8[7:0]								Duty(%) = Group7 [7:0] / 256

When you transmit data of the group setting, please be careful because data of the individual setting update it.

# MECHANICAL CASE OUTLINE

## PACKAGE DIMENSIONS

ON Semiconductor®



### QFN48 7x7, 0.5P CASE 485EB ISSUE O

DATE 07 JUL 2015

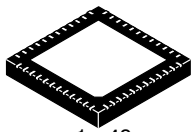

1 48  
SCALE 2:1

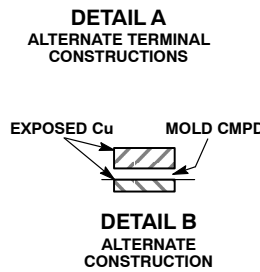
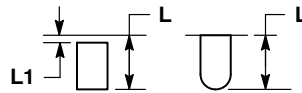
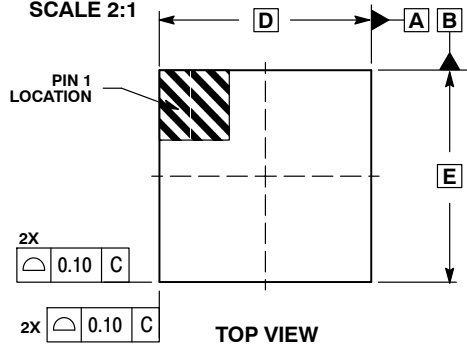

NOTES:

1. DIMENSIONS AND TOLERANCING PER ASME Y14.5M, 1994.
2. CONTROLLING DIMENSION: MILLIMETERS.
3. DIMENSION b APPLIES TO THE PLATED TERMINAL AND IS MEASURED BETWEEN 0.15 AND 0.25 MM FROM THE TERMINAL TIP.
4. COPLANARITY APPLIES TO THE EXPOSED PAD AS WELL AS THE TERMINALS.

MILLIMETERS		
DIM	MIN	MAX
A	0.80	0.90
A1	0.00	0.05
A3	0.20	REF
b	0.20	0.30
D	7.00	BSC
D2	5.20	5.40
E	7.00	BSC
E2	5.20	5.40
e	0.50	BSC
L	0.35	0.45
L1	0.00	0.15

#### GENERIC MARKING DIAGRAM\*

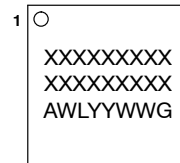

- A = Assembly Location
- WL = Wafer Lot
- YY = Year
- WW = Work Week
- G = Pb-Free Package

\*This information is generic. Please refer to device data sheet for actual part marking.  
Pb-Free indicator, "G" or microdot "▪", may or may not be present.

#### RECOMMENDED SOLDERING FOOTPRINT\*

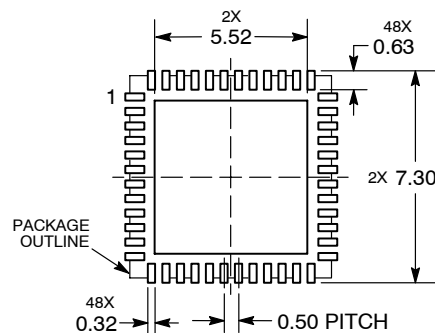

DIMENSIONS: MILLIMETERS

\*For additional information on our Pb-Free strategy and soldering details, please download the ON Semiconductor Soldering and Mounting Techniques Reference Manual, SOLDERRM/D.

DOCUMENT NUMBER:	98AON99699F	Electronic versions are uncontrolled except when accessed directly from the Document Repository. Printed versions are uncontrolled except when stamped "CONTROLLED COPY" in red.
DESCRIPTION:	QFN48 7X7, 0.50P	PAGE 1 OF 1

ON Semiconductor and ON are trademarks of Semiconductor Components Industries, LLC dba ON Semiconductor or its subsidiaries in the United States and/or other countries. ON Semiconductor reserves the right to make changes without further notice to any products herein. ON Semiconductor makes no warranty, representation or guarantee regarding the suitability of its products for any particular purpose, nor does ON Semiconductor assume any liability arising out of the application or use of any product or circuit, and specifically disclaims any and all liability, including without limitation special, consequential or incidental damages. ON Semiconductor does not convey any license under its patent rights nor the rights of others.

ON Semiconductor and  are trademarks of Semiconductor Components Industries, LLC dba ON Semiconductor or its subsidiaries in the United States and/or other countries. ON Semiconductor owns the rights to a number of patents, trademarks, copyrights, trade secrets, and other intellectual property. A listing of ON Semiconductor's product/patent coverage may be accessed at [www.onsemi.com/site/pdf/Patent-Marking.pdf](http://www.onsemi.com/site/pdf/Patent-Marking.pdf). ON Semiconductor reserves the right to make changes without further notice to any products herein. ON Semiconductor makes no warranty, representation or guarantee regarding the suitability of its products for any particular purpose, nor does ON Semiconductor assume any liability arising out of the application or use of any product or circuit, and specifically disclaims any and all liability, including without limitation special, consequential or incidental damages. Buyer is responsible for its products and applications using ON Semiconductor products, including compliance with all laws, regulations and safety requirements or standards, regardless of any support or applications information provided by ON Semiconductor. "Typical" parameters which may be provided in ON Semiconductor data sheets and/or specifications can and do vary in different applications and actual performance may vary over time. All operating parameters, including "Typicals" must be validated for each customer application by customer's technical experts. ON Semiconductor does not convey any license under its patent rights nor the rights of others. ON Semiconductor products are not designed, intended, or authorized for use as a critical component in life support systems or any FDA Class 3 medical devices or medical devices with a same or similar classification in a foreign jurisdiction or any devices intended for implantation in the human body. Should Buyer purchase or use ON Semiconductor products for any such unintended or unauthorized application, Buyer shall indemnify and hold ON Semiconductor and its officers, employees, subsidiaries, affiliates, and distributors harmless against all claims, costs, damages, and expenses, and reasonable attorney fees arising out of, directly or indirectly, any claim of personal injury or death associated with such unintended or unauthorized use, even if such claim alleges that ON Semiconductor was negligent regarding the design or manufacture of the part. ON Semiconductor is an Equal Opportunity/Affirmative Action Employer. This literature is subject to all applicable copyright laws and is not for resale in any manner.

## PUBLICATION ORDERING INFORMATION

### LITERATURE FULFILLMENT:

Email Requests to: [orderlit@onsemi.com](mailto:orderlit@onsemi.com)

ON Semiconductor Website: [www.onsemi.com](http://www.onsemi.com)

### TECHNICAL SUPPORT

North American Technical Support:  
Voice Mail: 1 800-282-9855 Toll Free USA/Canada  
Phone: 011 421 33 790 2910

### Europe, Middle East and Africa Technical Support:

Phone: 00421 33 790 2910

For additional information, please contact your local Sales Representative